

1955

MERCEDES-BENZ

300 SL

GULLWING



Pack 02

BUILD INSTRUCTIONS

STAGE 05: THE FRONT BUMPER, OVERRIDERS,
AND LICENSE PLATE

STAGE 06: THE CRANKCASE AND
THE OIL RADIATOR

STAGE 07: THE ENGINE CYLINDER HEAD

STAGE 08: THE ENGINE INTAKE HOSE

STAGE 09: THE CYLINDER HEAD COVER AND
THE DISTRIBUTOR

STAGE 10: THE ALTERNATOR AND
THE WATER PUMP

"MERCEDES-BENZ" and  are the intellectual property of Mercedes-Benz Group AG.
They are used by Agora Models under license.

AGORA
MODELS

Advice from the experts

Spare screws are included with each part. Occasionally, you may be instructed to keep spare or unused screws for a later stage. Keep these spares in a safe place and label them correctly.

Please make sure you don't mix up the screws. They look quite similar, but the threads do vary slightly. Using the wrong screws may damage the parts.

When securing parts together using multiple screws, fit each screw loosely to ensure all the parts are correctly aligned before gently tightening them firmly, but not overtight, in the order in which you placed them.

The screwdriver can be magnetized by stroking it with a magnet (fridge magnet, etc.) enabling it to hold the screws and make assembly easier.

If a screw is tight going into a metal part, do not force it as you may shear the head off. Remove it and put a tiny smear of Vaseline, soap or light oil on the thread. That will lubricate it and make it easier to drive home.

During the course of this build, you will receive many pieces that you will assemble immediately – following the instructions in the corresponding stage – and other pieces that you should store safely to one side, for use in future assembly stages.

Left and Right! When building your Mercedes-Benz 300SL, the left or right hand side refers to each side as you are sitting in the car.



WARNING: Some parts are assembled using magnets. These magnets can cause serious injury if they are swallowed. Keep away from children. If you suspect a magnet has been swallowed, seek medical help straight away.

STAGE 5: THE FRONT BUMPER, OVERRIDERS, AND LICENSE PLATE

For the first stage of this pack, you will assemble the bumper with its two protective overrides, as well as the front license plate.



STAGE 5 - REQUIRED PARTS

Code	Name	Quantity	Material
05A	Front bumper	1	ABS
05B	Front license plate	1	ABS
05C	Left bumper override	1	Zinc
05D	Right bumper override	1	Zinc
05E	Left support	1	Zinc
05F	Right support	1	Zinc
HP	Screws 2 x 4mm	6 + 2*	Iron
MM	Screws 2.3 x 4mm	2 + 1*	Iron

* Replacement screws included



01 ASSEMBLING THE LEFT BUMPER OVERRIDER

Insert the left override **05C**, identified with the letter "L", into the left hole of the bumper **05A**, as shown. The lower part of the override has a semicircular convex shape. Inside, there is a pin that must be inserted into the corresponding hole in the bumper. Fix the override in place with an **MM** screw.

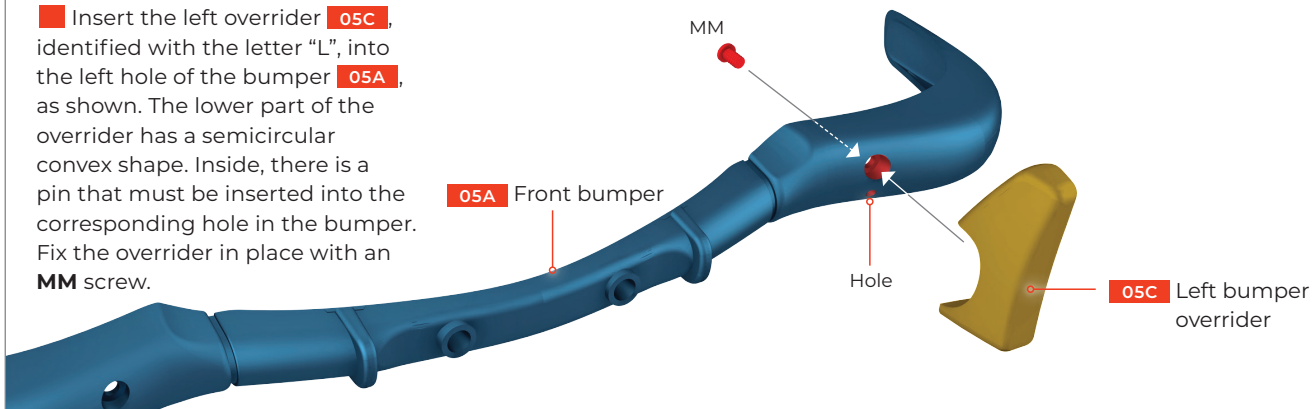

02 ASSEMBLING THE RIGHT BUMPER OVERRIDER

The right override of the bumper **05D** is identified with the letter "R". Insert it into the right hole of the bumper **05A** and attach it with an **MM** screw.

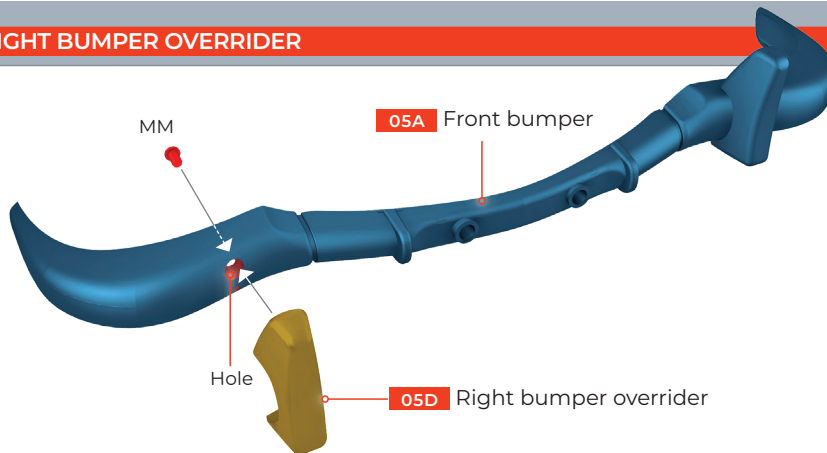

03 THE LEFT BUMPER SUPPORT

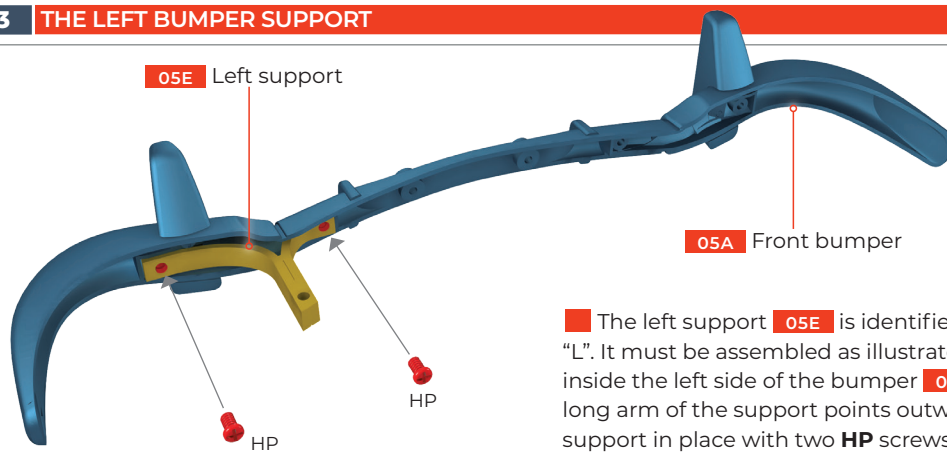

The left support **05E** is identified with the letter "L". It must be assembled as illustrated in the figure, inside the left side of the bumper **05A** so that the long arm of the support points outwards. Fix the support in place with two **HP** screws.

04 THE RIGHT BUMPER SUPPORT

The right support **05F** is identified with the letter "R". It must be assembled on the right side of the bumper **05A** so that the long arm of the support points outwards. Fix the support in place with two **HP** screws.

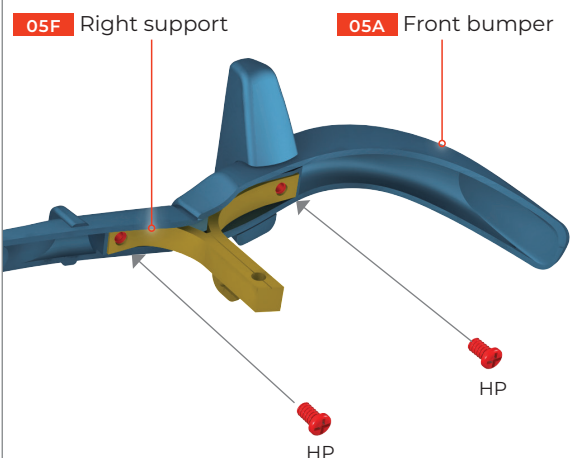

05 FITTING THE LICENSE PLATE

The license plate **05B** is fixed in place with two **HP** screws through the holes in the center of the bumper **05A**.

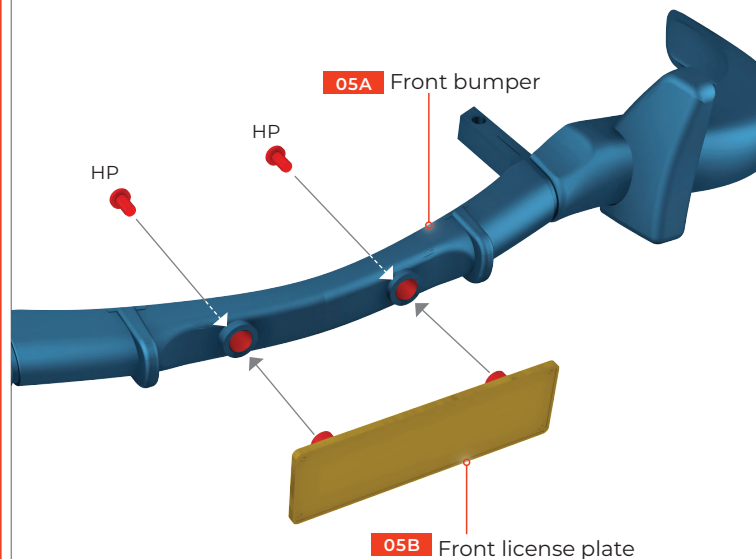

When fixing the license plate in place, make sure it is in the correct position. Otherwise, when you fit the bumper onto the model later on, the numbers will be upside-down.

STAGE 6: THE CRANKCASE AND THE OIL RADIATOR

In this stage, you will assemble the oil radiator, then fix it to the left side of the crankcase. After that, you'll attach the crankcase to the left engine block.

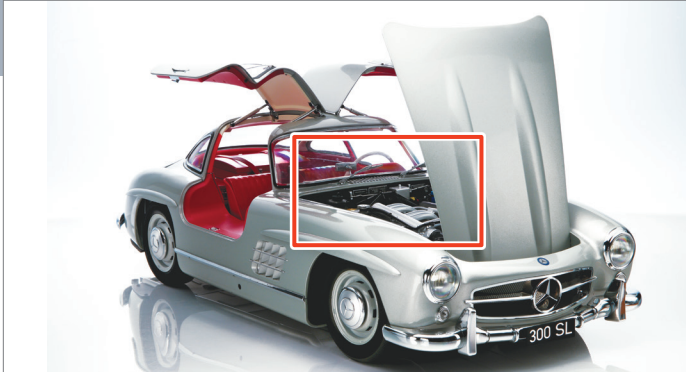

STAGE 6 - REQUIRED PARTS

Code	Name	Quantity	Material
06A	Crankcase	1	Zinc
06B	Oil filter	1	ABS
06C	Cover (oil radiator)	1	ABS
06D	Tank (oil radiator)	1	ABS
06E	Pipe (oil radiator)	1	ABS
CM	Screws 2 x 4mm	2 + 1*	Iron
MM	Screws 2.3 x 4mm	1 + 1*	Iron
CP	Screws 1.7mm x 3mm x 4.5mm	1 + 1*	Iron
EP	Screws 1.7 x 4mm	1 + 1*	Iron

* Replacement screws included

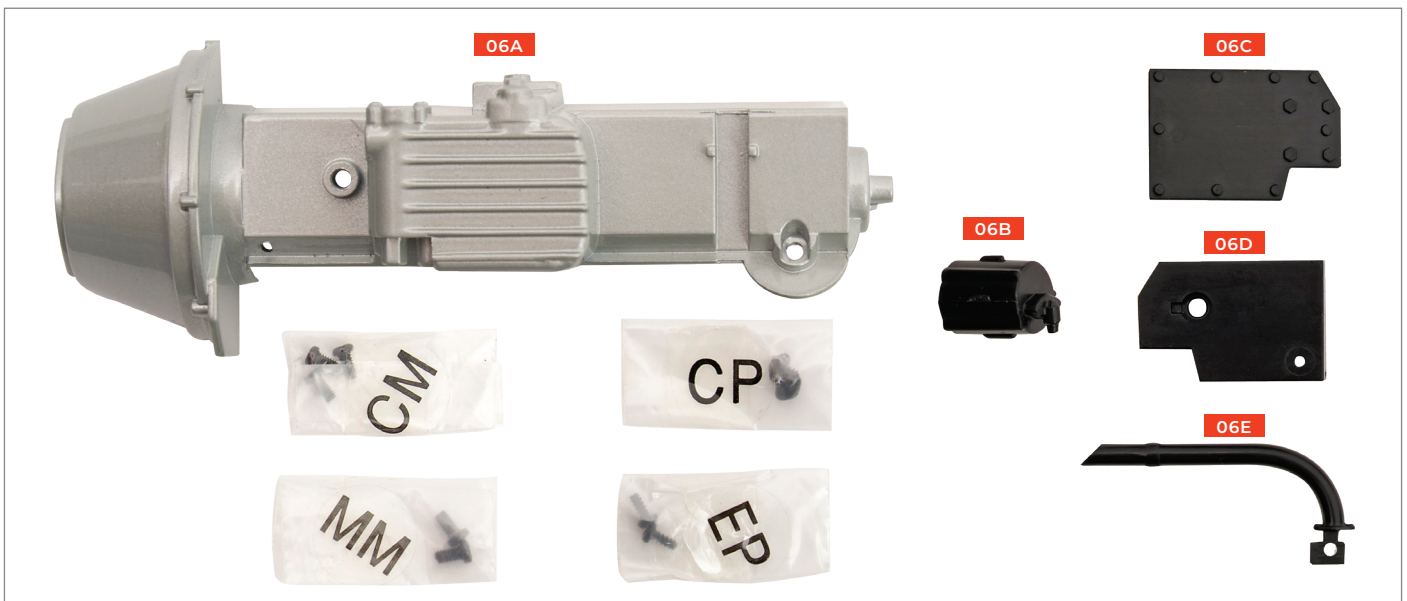

01 ASSEMBLING THE OIL RADIATOR PIPE

Position the curved end of the oil radiator pipe **06E** in the notch on the contour of the oil tank **06D**, so that the holes in both parts line up and the pipe sits in the slot on the side of the oil radiator. Fix it in place with a **CP** screw.

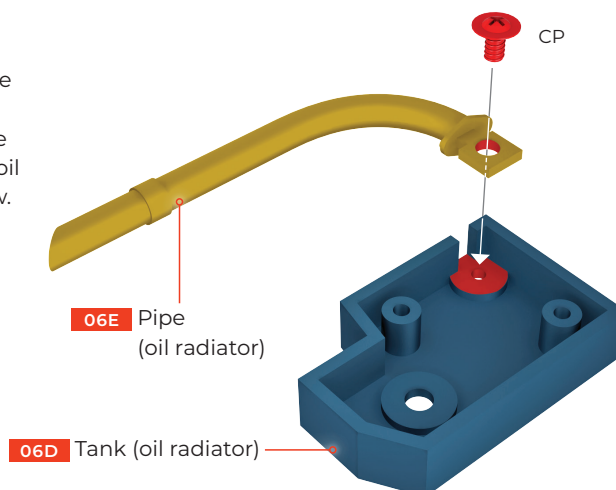

02 FITTING THE OIL RADIATOR TANK

Fit the tank **06D** onto the outer side of the crankcase **06A** and secure it with an **MM** screw, as shown.

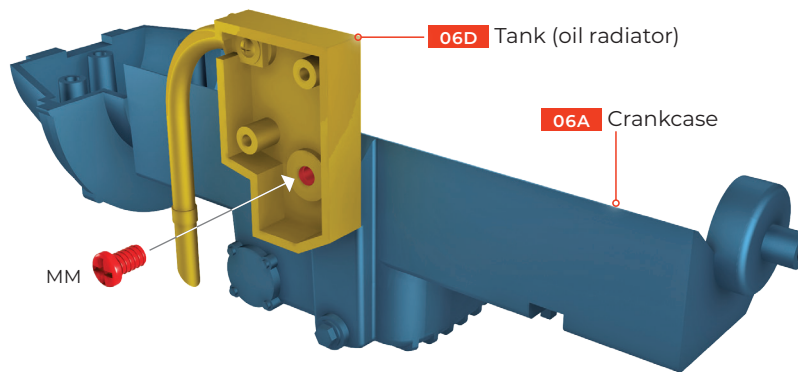

03 FITTING THE OIL RADIATOR COVER

Place the cover **06C** as shown. Press the piece onto the side of tank **06D** so that both pins fit into the matching holes inside the tank.

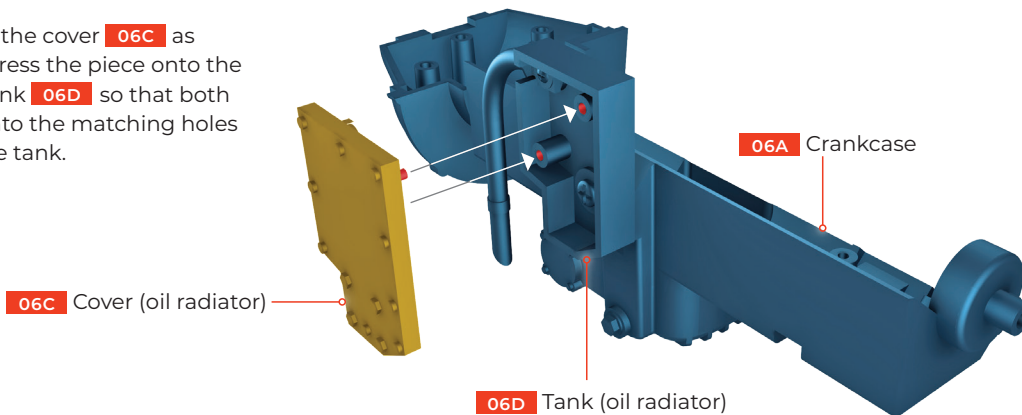

04 FITTING THE OIL FILTER

Place the oil filter **06B** onto the lower face of the crankcase **06A**, as shown. Fix it in place with an **EP** screw.

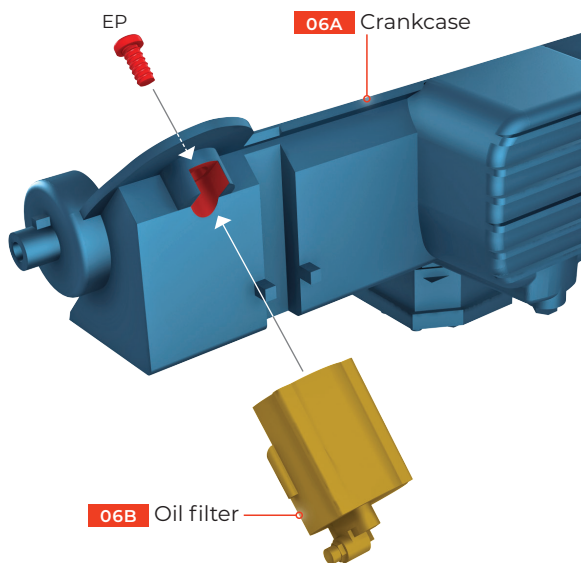

05 FITTING THE CRANKCASE

Take the left engine block **04A** you assembled in stage 4 and fit it inside the crankcase **06A**. The two tabs on the bottom surface should perfectly match the holes marked on the crankcase. Fix it in place with two **CM** screws.

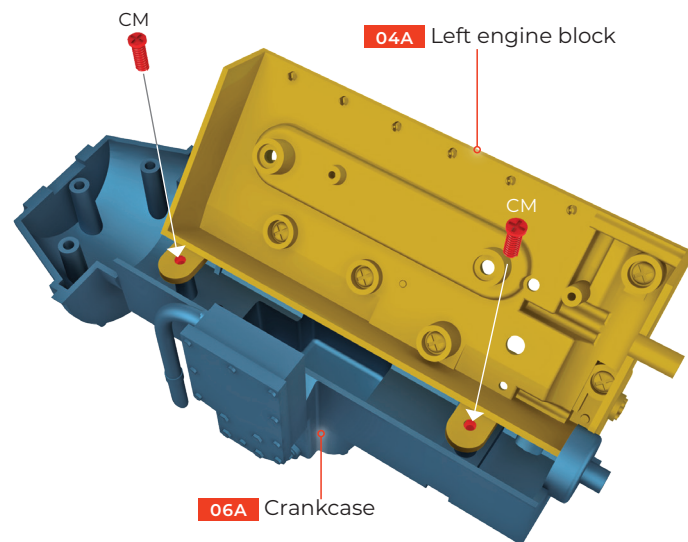

The self-tapping **CM** screws create their own thread as they are screwed in. To do this, screw the **CM** in halfway, and then remove it and the shavings. Next, screw the **CM** in all the way, holding the screwdriver tight and applying gentle pressure.

STAGE 7: THE ENGINE CYLINDER HEAD

In this stage, you will join the exhaust manifolds to the engine cylinder head and fit the exhaust front pipe.

COLOR CODING

The color coding of the parts shows how they should be put together.

RED indicates the screws and the correct position.

YELLOW indicates new parts.

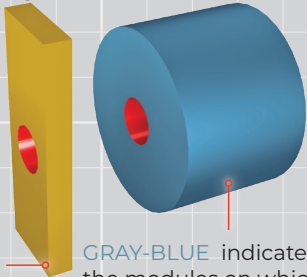

GRAY-BLUE indicates the modules on which the new parts should be assembled.

STAGE 7 – REQUIRED PARTS

Code	Name	Quantity	Material
07A	Engine cylinder head	1	Zinc
07B	Front exhaust manifold	1	ABS
07C	Rear exhaust manifold	1	ABS
07D	Exhaust front pipe	1	ABS
07E	Exhaust front pipe connector seal	2	ABS
DM	Screws 2 x 4 x 5mm	4 + 2*	Iron

* Replacement screws included

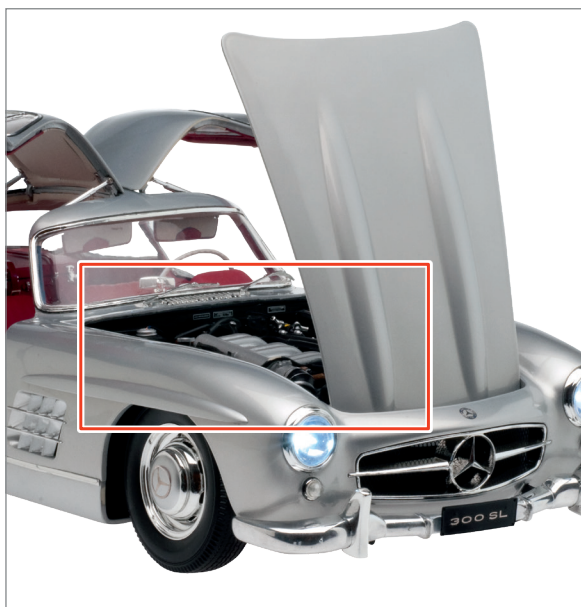

01 FITTING THE FRONT EXHAUST MANIFOLD

Take the front exhaust manifold **07B** and position it on the engine cylinder head **07A**, with the two ends inserted into the front holes as shown in the image. Make sure the manifold is pointing downwards then fix the piece in place with two **DM** screws.

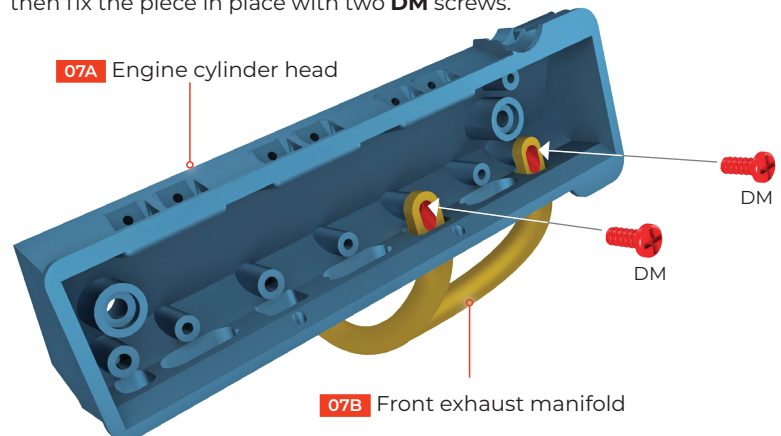

02 FITTING THE REAR EXHAUST MANIFOLD

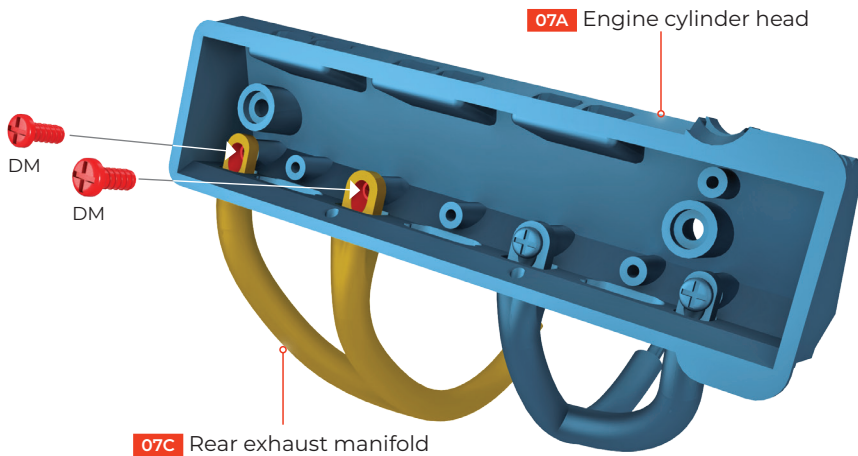

Assemble the rear exhaust manifold **07C** by inserting its ends into the two matching holes of the engine cylinder head **07A**, then securing with two **DM** screws.

03 FITTING THE EXHAUST FRONT PIPE CONNECTOR SEALS

Take one of the two exhaust front pipe connector seals **07E**, and gently introduce it in the free end of the front exhaust manifold **07B** with the narrow side pointing upward. Repeat this procedure with the other exhaust front pipe connector seal, which should be fitted into the rear exhaust manifold **07C**.

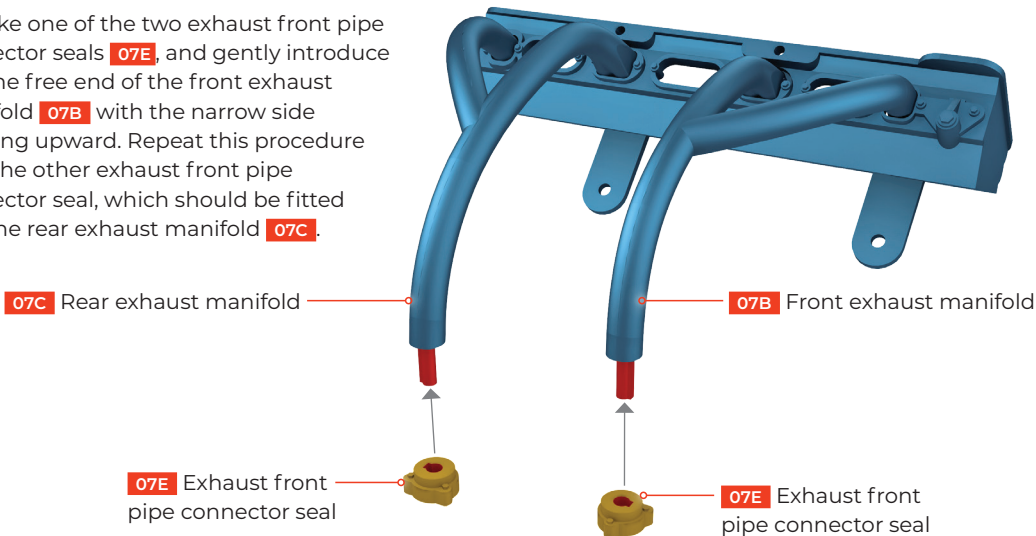

Caution!
The manifolds must be assembled with the free ends pointing downward. Later, they will connect with the exhaust front pipe.

04 CONNECTING THE EXHAUST FRONT PIPE

Now take the exhaust front pipe **07D** and fit it onto the two ends of the manifolds. Press both pinholes of the exhaust front pipe onto the connectors of each manifold **07B** and **07C**, as shown in the image.

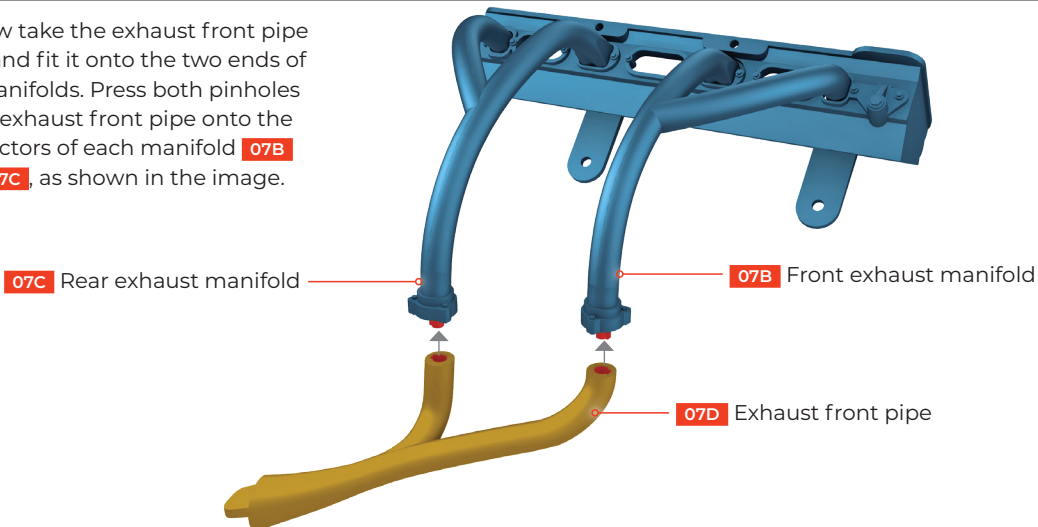

STAGE 8: THE ENGINE INTAKE HOSE

In this stage, the parts of the engine intake hose will be assembled and fixed to the engine cylinder head.

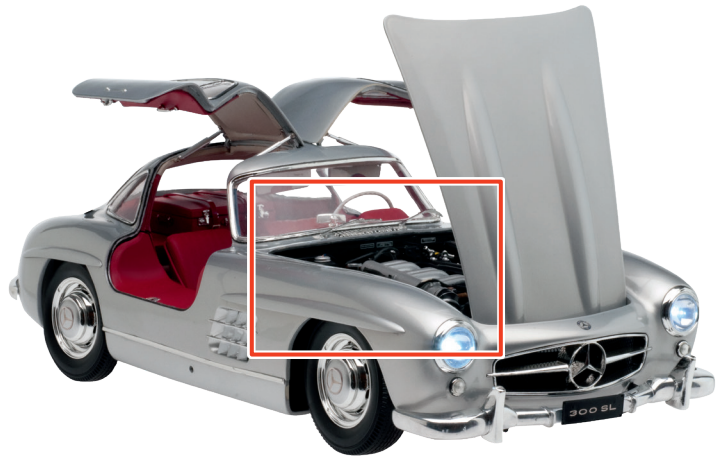

STAGE 8 - REQUIRED PARTS

Code	Name	Quantity	Material
08A	Engine intake hose	1	ABS
08B	Intake pipes heat shield	1	ABS
08C	Intake hose branch	1	ABS
08D	Inlet hose parts	1	ABS
08E	Intake air pipe left side	1	ABS
08F	Compression pipe upper	1	ABS
08G	Intake air pipe right side	1	ABS
08H	Compression pipe lower	1	ABS
CM	Screw 2 x 4mm	3 + 1*	Iron
EP	Screw 1.7 x 4mm	4 + 2*	Iron
FP	Screw 1.7 x 4 x 4mm	1 + 1*	Iron
HP	Screw 2 x 4mm	2 + 1*	Iron
MP	Screw 2.3 x 4mm	2 + 1*	Iron

* Replacement screws included



01 FITTING THE INTAKE AIR PIPE LEFT SIDE IN THE ENGINE INTAKE HOSE

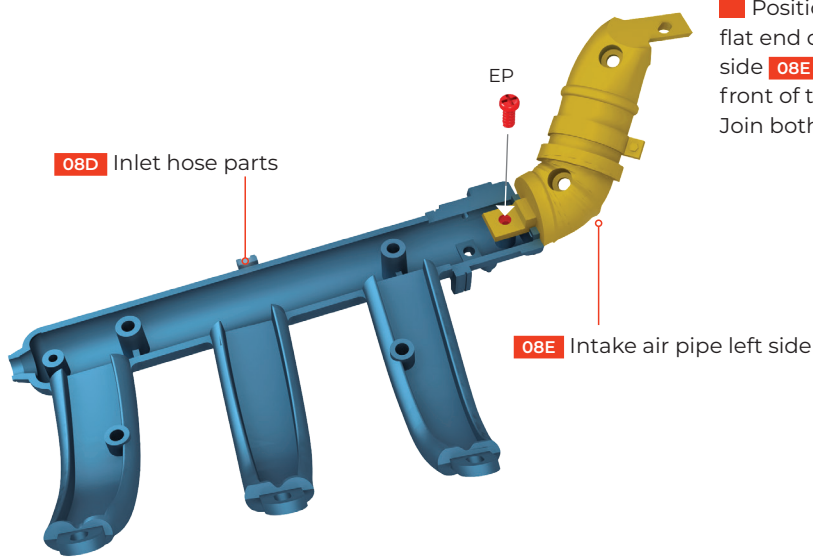

Position the flange on the flat end of the intake air pipe left side **08E** over the screw seat on the front of the inlet hose parts **08D**. Join both pieces with an **EP** screw.

02 FITTING THE INTAKE AIR PIPE RIGHT SIDE

Position the outer part of the intake air pipe right side **08G** into the intake air pipe left side **08E**, fitting them with precision. Fix the part in place with two **EP** screws.

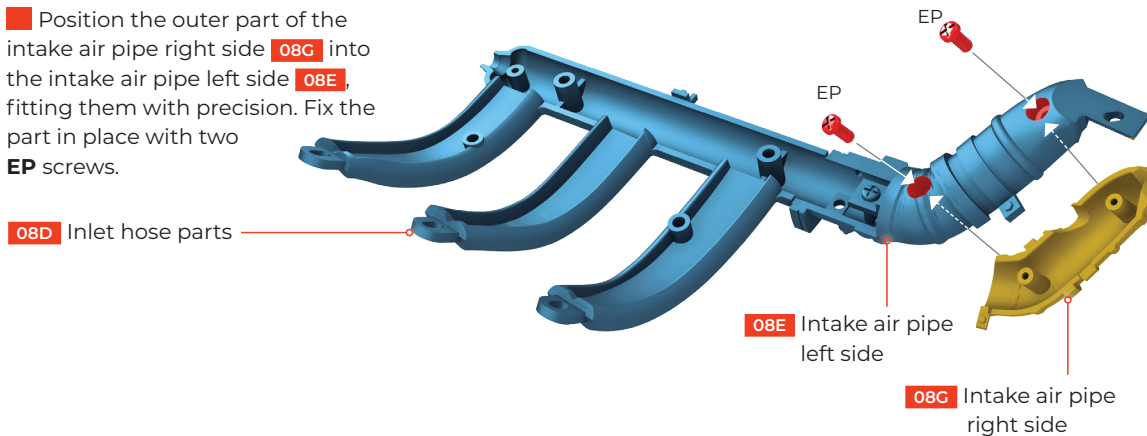

03 THE EXTERNAL PART OF THE COMPRESSION PIPE UPPER

Mount the outer part of the compression pipe upper **08F** onto the free end of the intake air pipe left side **08E**, as shown. Check that the part is joined to the outside of the intake air pipe right side **08G** before you fix it in place with an **EP** screw.

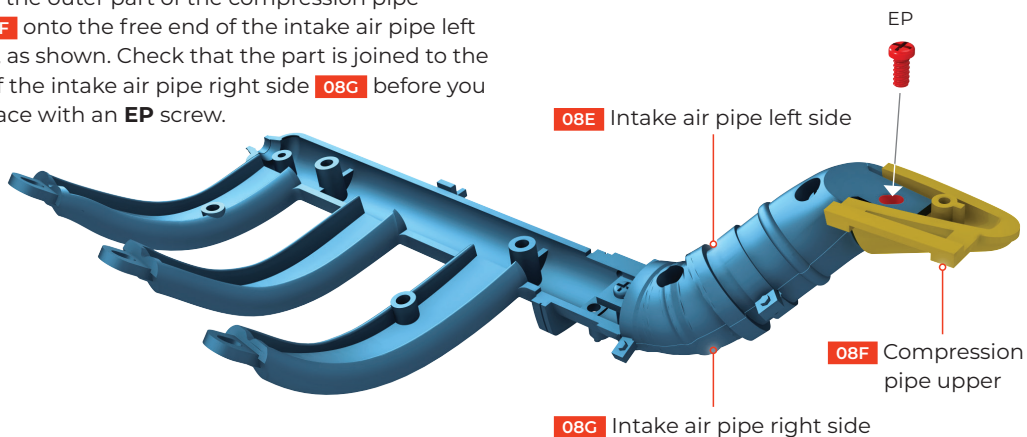

To avoid damaging the screws when tightening, hold the screwdriver tightly while applying firm pressure on the screw head.

04 THE COMPRESSION PIPE UPPER

Place the compression pipe lower **08H** on the screw seating in the inner side of the compression pipe upper **08F**, as shown. Secure with an **FP** screw.

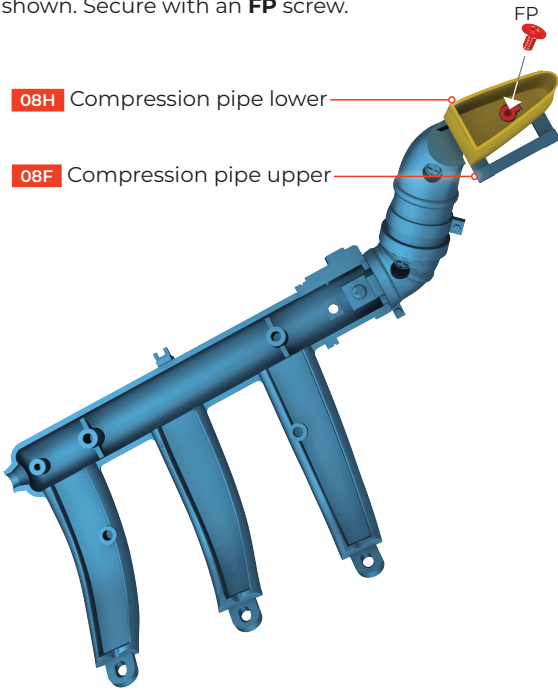

05 FITTING THE INTAKE HOSE BRANCH

Place the hole in the wide end of the intake hose branch **08C** onto the guide pin located next to the flat end of the engine intake hose **08A**.

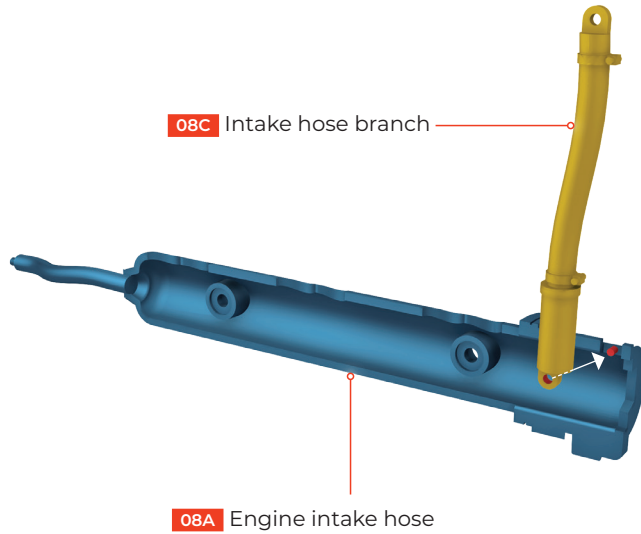

06 ASSEMBLING THE ENGINE INTAKE HOSE

Join the inlet hose parts **08D** with the engine intake hose **08A**, as shown. Check that the screw holes on both parts line up then fix the parts with two **MP** screws.

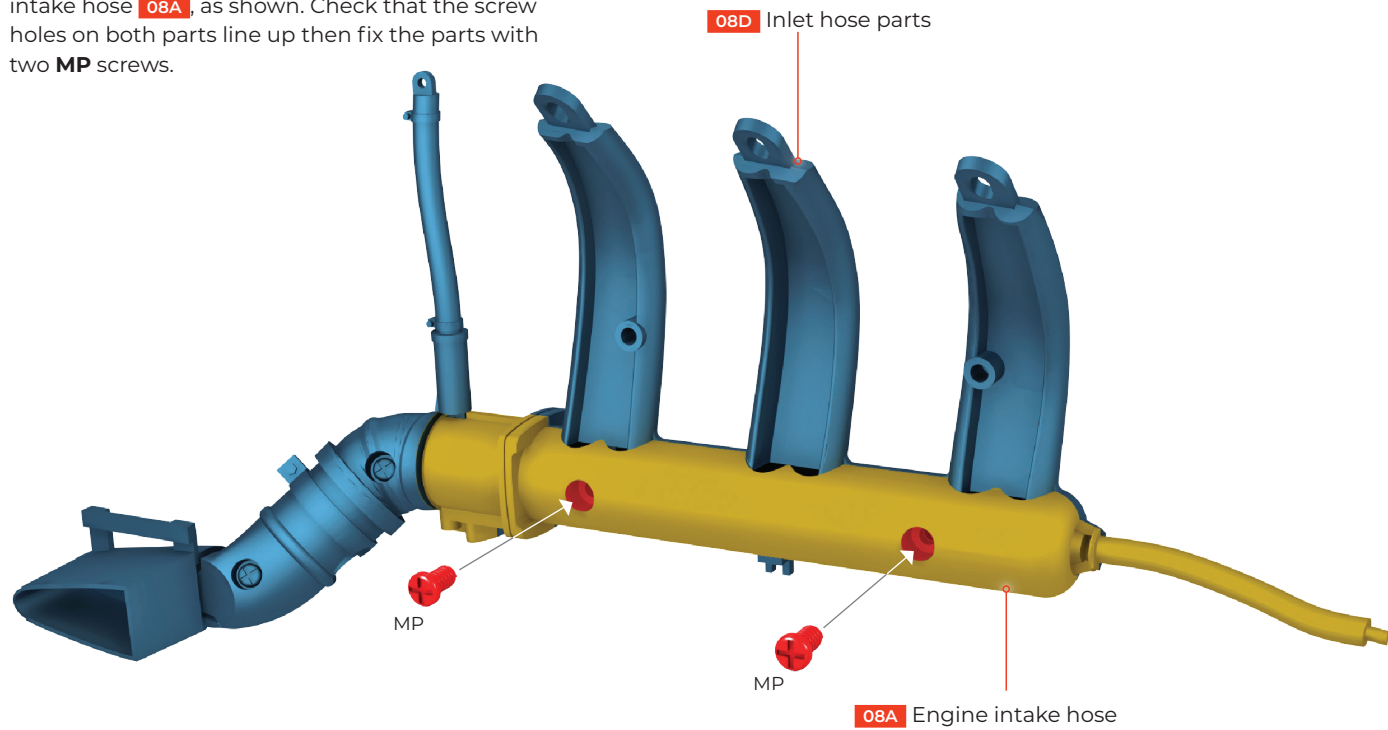

07 FITTING THE INTAKE PIPES HEAT SHIELD

Place the intake pipes heat shield **08B** onto the inner side of the engine intake hose **08A**. Make sure the screw holes line up then fix the parts with two **HP** screws.

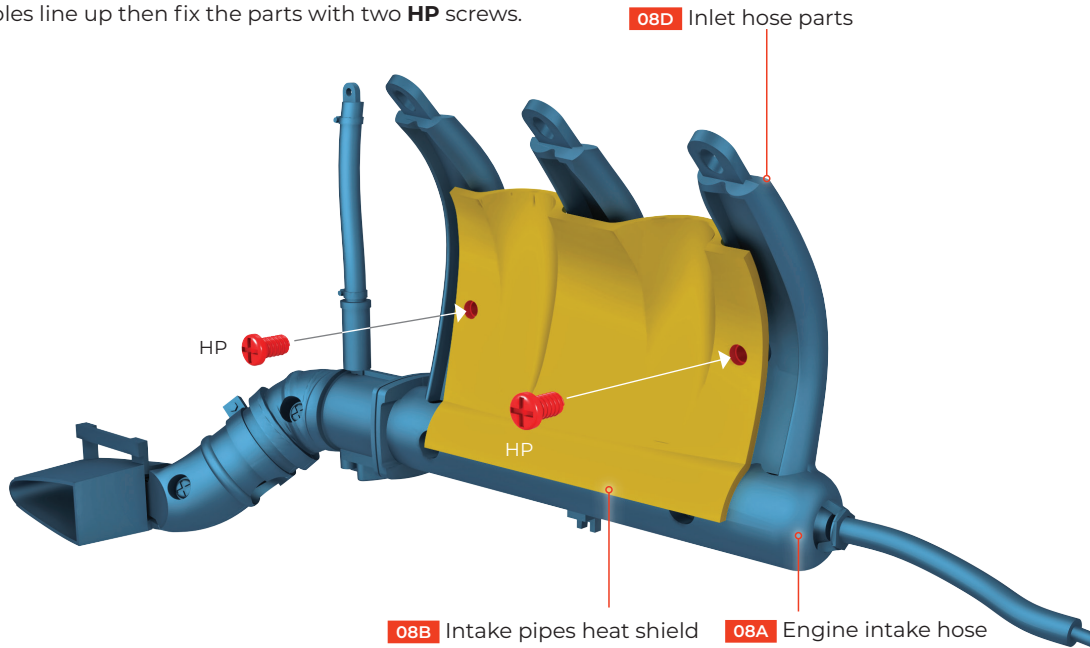

08 FITTING THE ENGINE INTAKE HOSE ONTO THE ENGINE CYLINDER HEAD

Insert the three free ends of the Inlet hose parts **08D** into the slots on the right-hand side of the engine cylinder head **07A**. The intake pipes heat shield **08B** should cover a good part of the exhaust manifold (**07B** and **07C**). Line up the holes and fix the ends of the engine intake hose to the engine cylinder head with three **CM** screws.

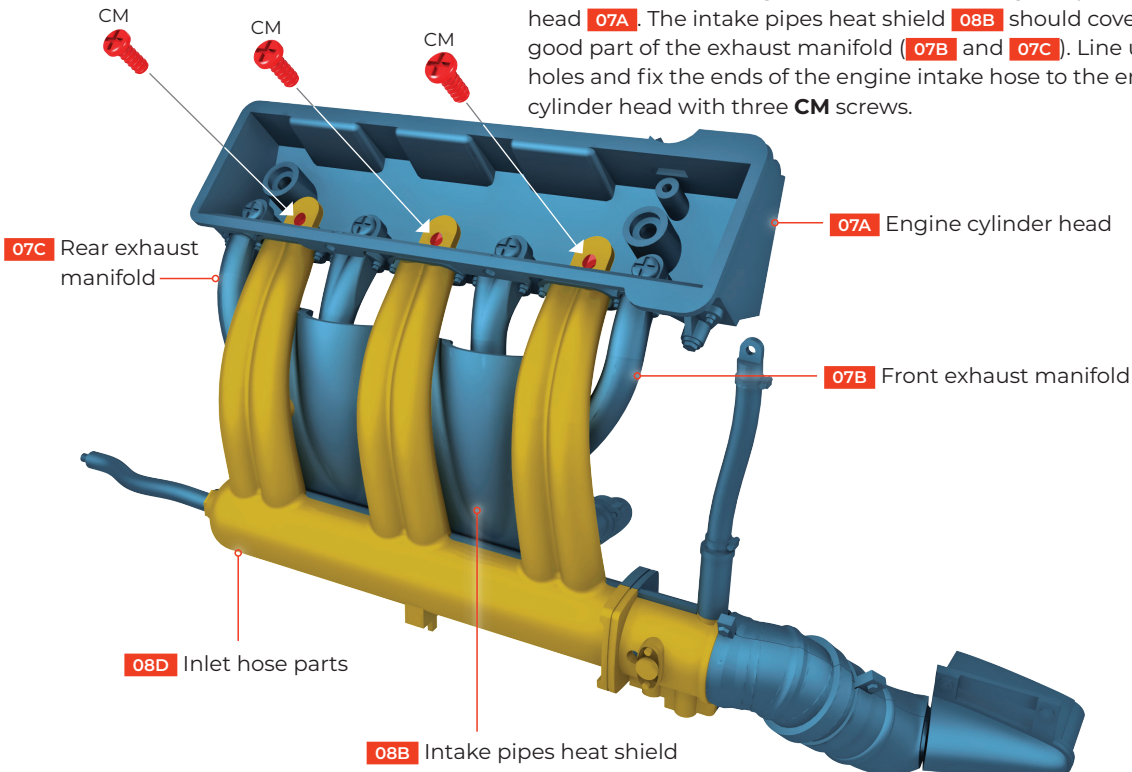

The self-tapping screws create their own thread when they are screwed in. For a perfect thread, first screw in halfway and then remove the screw. Remove all the shavings and then insert and tighten the screw all the way in, holding the screwdriver tightly and applying firm pressure.

STAGE 9: THE CYLINDER HEAD COVER AND THE DISTRIBUTOR

In this stage, you will install the cylinder head cover and fit the distributor and the ignition cable casing to the engine cylinder head. Next, you will fix the whole engine cylinder head assembly onto the left side of the engine block.

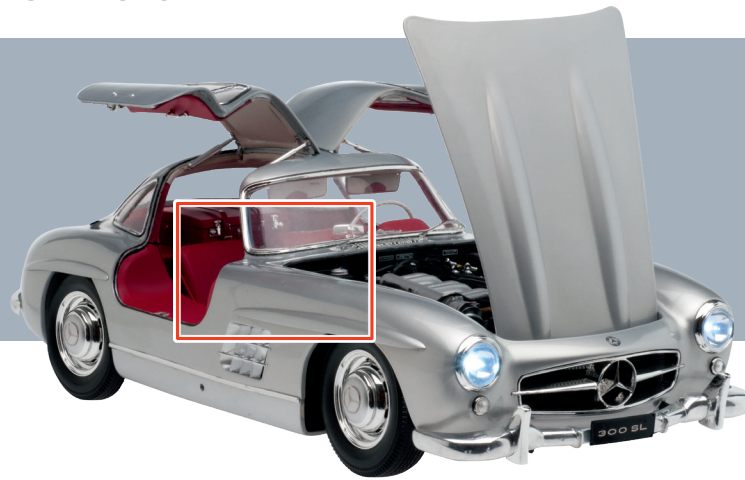

STAGE 9 - REQUIRED PARTS

Code	Name	Quantity	Material
09A	Cylinder head cover	1	ABS
09B	Oil filler cap	3	ABS
09C	Cylinder head oil line	1	ABS
09D	Ignition cable casing	1	ABS
09E	Ignition cable	1	PVC
09F	Spark plugs	3	ABS
09G	Distributor cables	1	PVC
09H	Distributor base	1	ABS
09I	Distributor	1	ABS
09J	Distributor cap	1	ABS
CM	Screw 2 x 4mm	3 + 1*	Iron
EP	Screw 1.7 x 4mm	1 + 1*	Iron
MP	Screws 2.3 x 4mm	2 + 1*	Iron

* Replacement screws included

01 FITTING THE DISTRIBUTOR BASE

Position the distributor base **09H** with the cylinder pointing downward. Next, insert its square flange into the slot on the engine cylinder head **07A** as shown. Align the holes in both pieces and fix them with a **CM** screw.

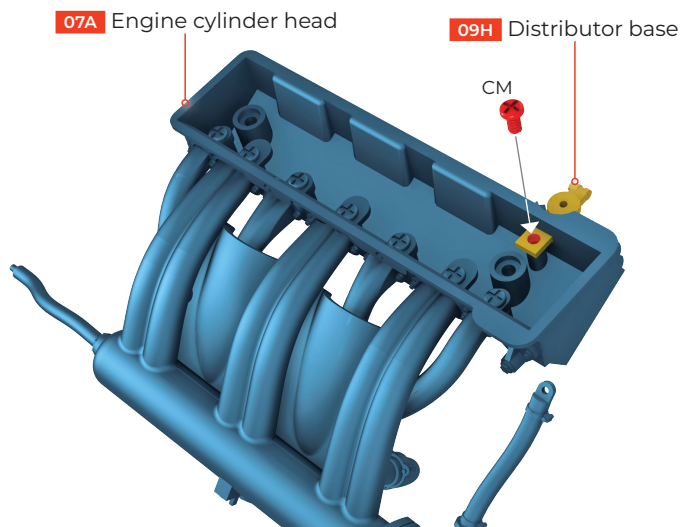

02 ASSEMBLING THE DISTRIBUTOR

Place the distributor **09I** on the base **09H**, orienting it as shown in the picture. Fix the distributor in place with an **EP** screw.

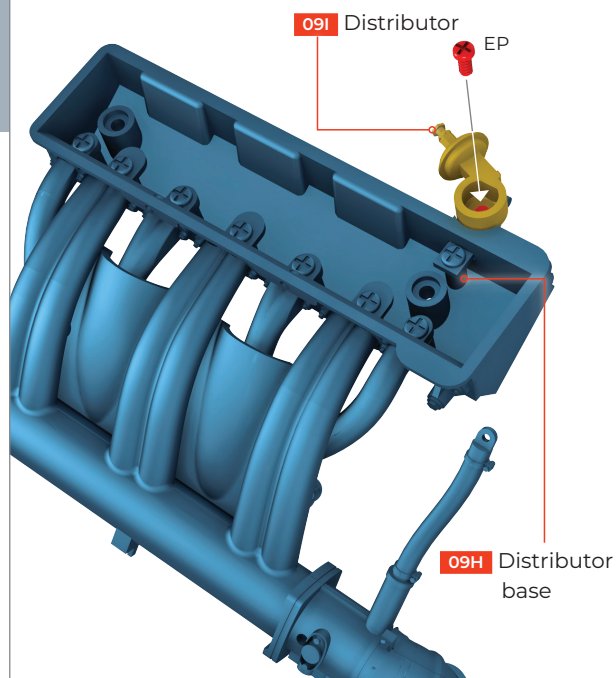

03 FITTING THE DISTRIBUTOR CAP

Push the distributor cap **09J** into the upper surface of the distributor **09I** until completely set.

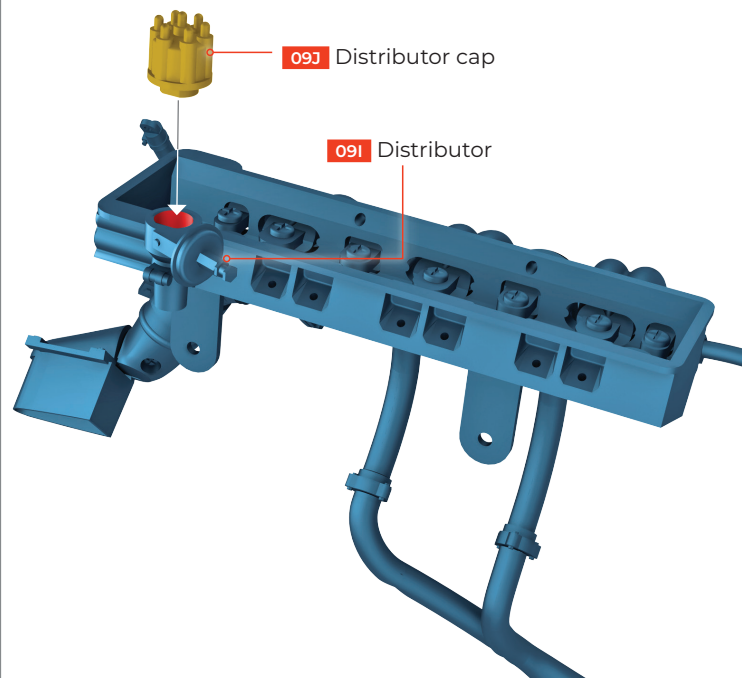

04 ASSEMBLING THE CYLINDER HEAD COVER

Place the cylinder head cover **09A** onto the engine cylinder head **07A** so that its widest end is pointing forward. Fix it in place by inserting two **MP** screws from underneath the engine cylinder head.

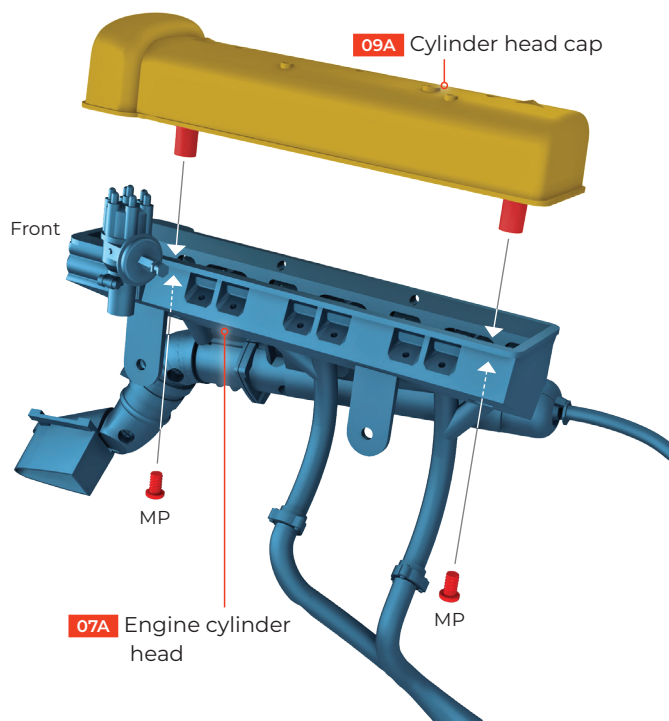

05 FITTING THE OIL FILLER CAPS

Insert the three oil filler caps **09B** into the three central holes in the upper side of the cylinder head cover **09A**.

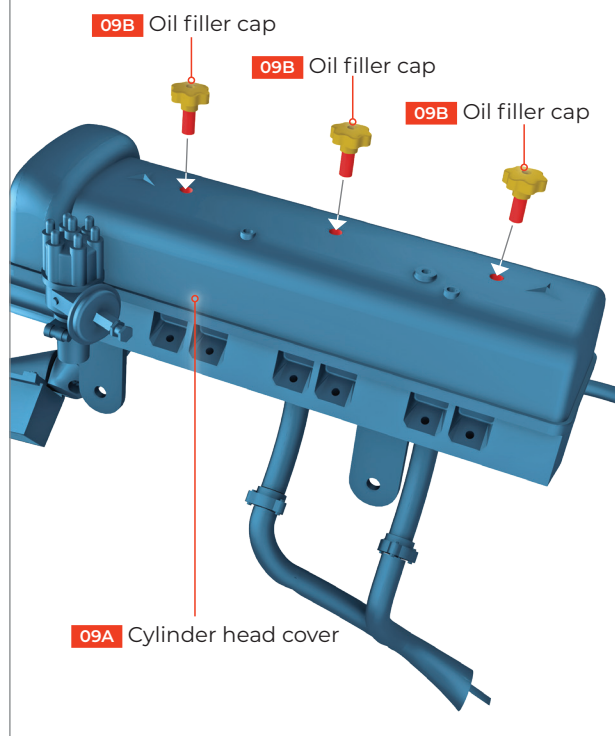

06 ASSEMBLING THE LEFT ENGINE BLOCK

Position the engine cylinder head **07A** and the left engine block **04A** as shown in the picture. Next, join both parts so the holes in the brackets on the bottom side of the engine cylinder head match the indicated screw seatings in the center of the engine block, as shown in the image. Join both parts with two **CM** screws.

07A Engine cylinder head

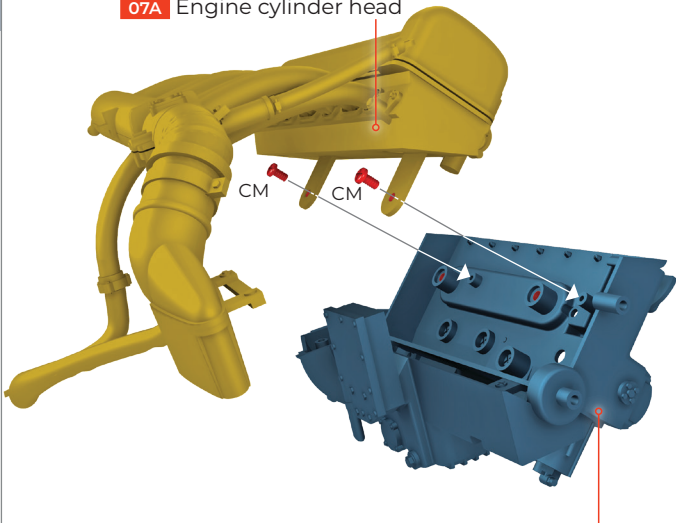

04A Left engine block

07 ASSEMBLING THE IGNITION CABLE CASING

Take the ignition cable casing **09D** and position each of the three pairs of spark plugs **09F** to the three indicated guide pins of the ignition cable casing **09D**. Check orientation of the parts. Insert each connector in the corresponding guide pin on the bottom side of the casing, so the spark plugs protrude through the depressions on the duct.

09D Ignition cable casing

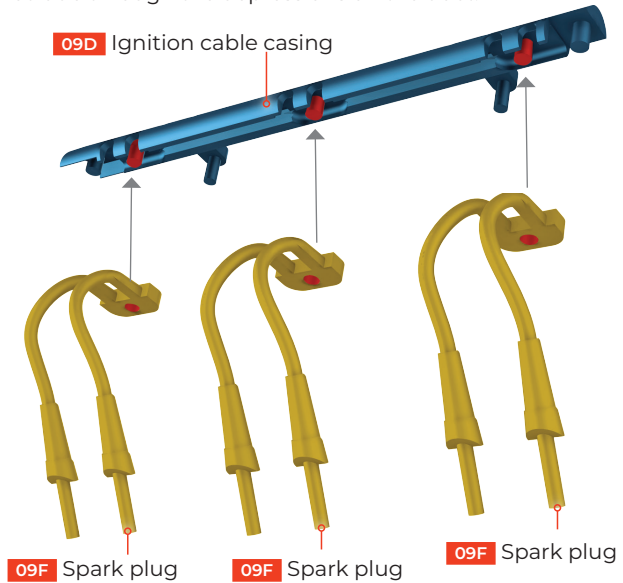

09F Spark plug

09F Spark plug

09F Spark plug

08 ASSEMBLING THE DISTRIBUTOR CABLES

Press-fit the opening at the end of the distributor cables **09G** into the pin at the front end of the ignition cable casing **09D**. The free ends of the casing should point forward.

09D Ignition cable casing

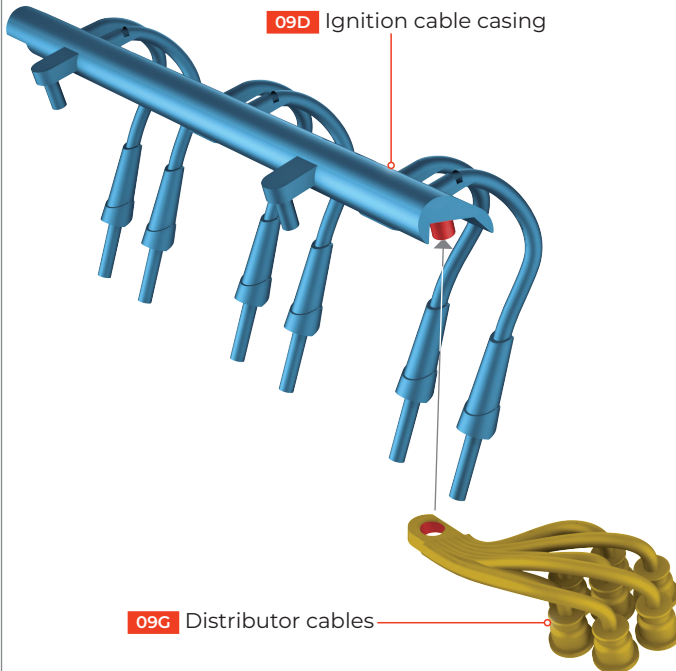

09G Distributor cables

09 FASTENING THE STARTER CABLE

Press-fit the opening at the end of the ignition cable **09E** into the pin at the back end of the ignition cable casing **09D**. The free end of the cable should point toward the rear end of the casing.

09D Ignition cable casing

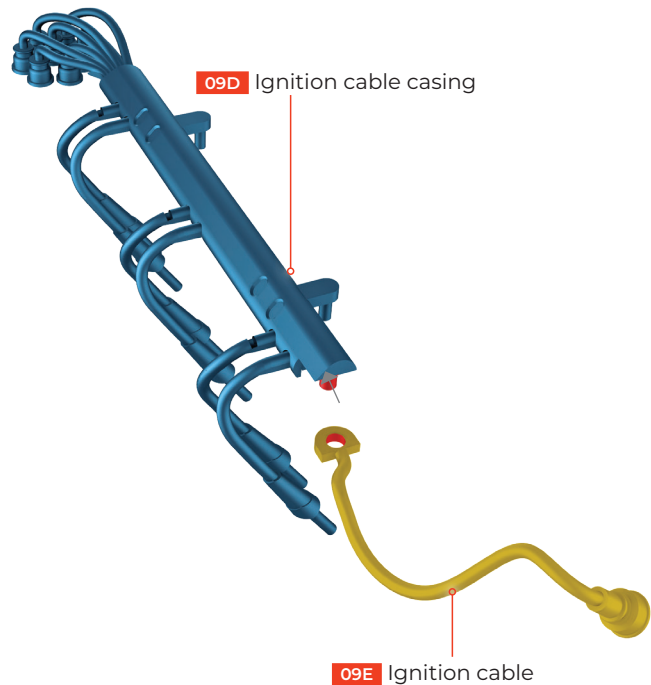

09E Ignition cable

10 ASSEMBLING THE IGNITION CABLE CASING

Position the ignition cable casing **09D** on the cylinder head cover **09A**. Insert the six ends of the spark plugs **09F** into the six marked sockets of the engine cylinder head **07A**, as indicated on the diagram. At the same time, the two guide pins at the bottom side of the ignition cable casing **09D** must be inserted into the holes in the upper surface of the cylinder head cover **09A**.

07A Engine cylinder head

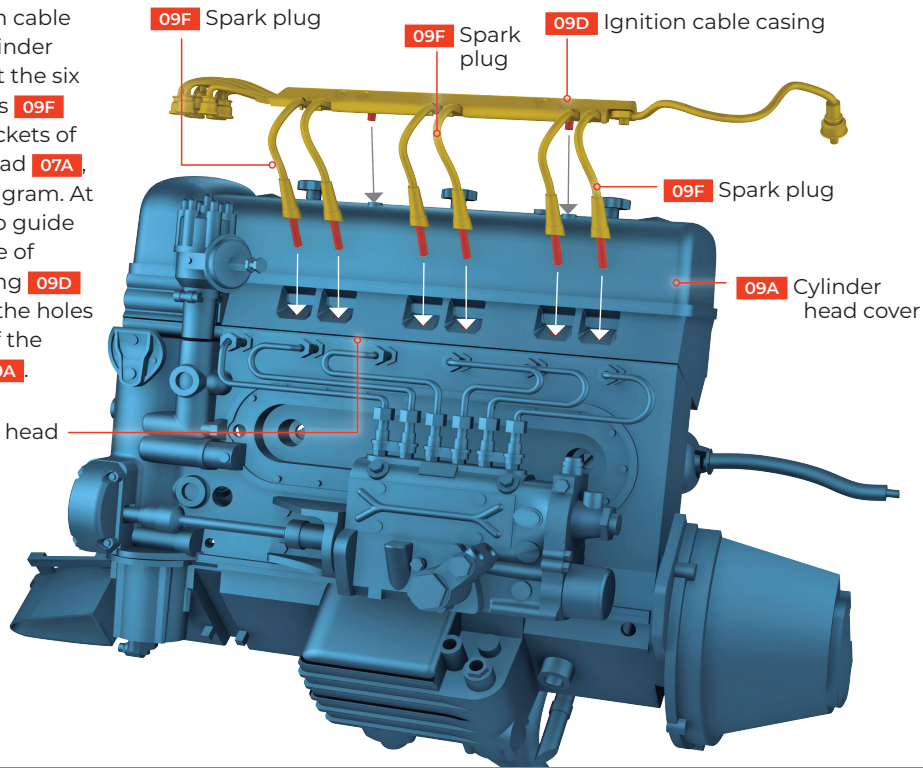

Pay close attention when inserting the spark plugs into their sockets, to keep the bolts at the tips from breaking!

11 CONNECTING THE DISTRIBUTOR CABLES

With a pair of tweezers, connect each of the seven cables of the distributor cables **09G** to the top lid of the distributor cap **09J**.

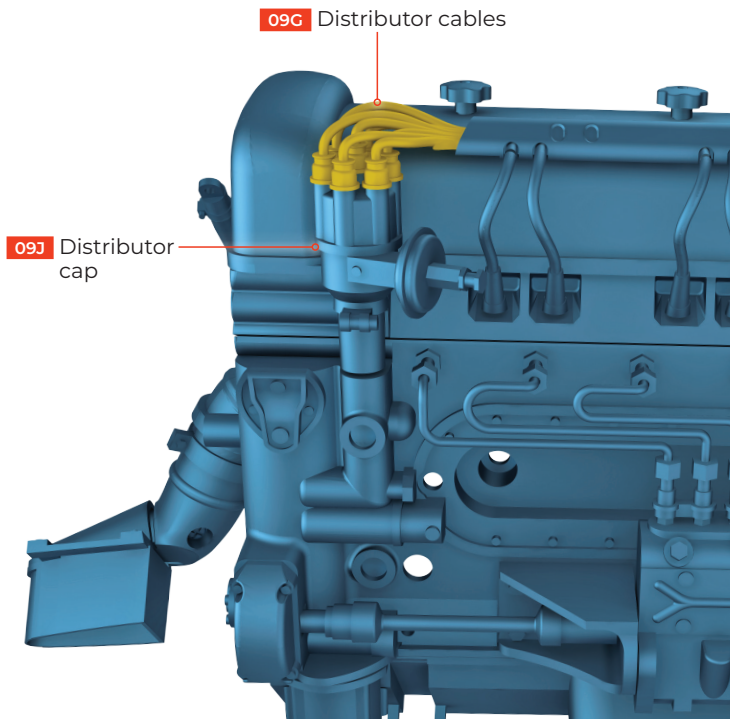

12 CYLINDER HEAD OIL LINE

Take the cylinder head oil line **09C** and insert the pin at the widest end of it into the hole on the upper surface of the cylinder head cover **09A**. The loose end of the tube should be pointing towards the left side of the engine.

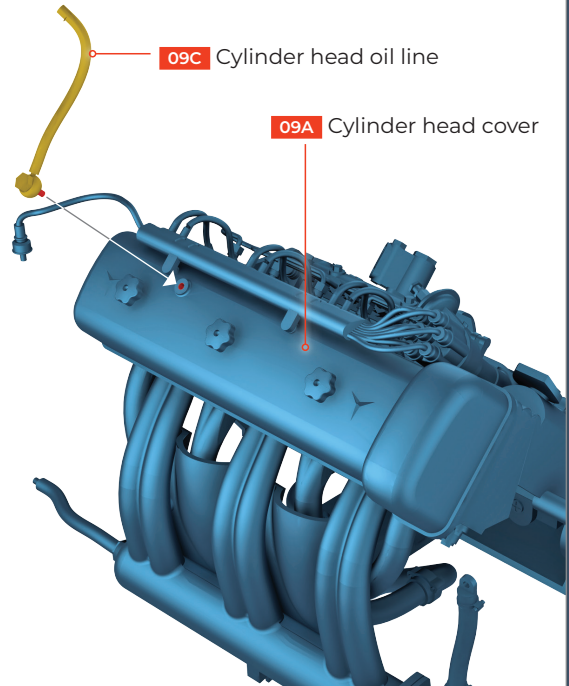

STAGE 10: THE ALTERNATOR AND THE WATER PUMP

In this stage, you will assemble the alternator then connect it to the water pump and the alternator shield. Then, you will fit the whole set to the right engine block. Finally, you will put the two sides of the engine block together.



STAGE 10 - REQUIRED PARTS

Code	Name	Quantity	Material
10A	Right engine block	1	Zinc
10B	Alternator	1	ABS
10C	Alternator fan	1	ABS
10D	Pulley	1	ABS
10E	Pulley spacer	1	ABS
10F	Alternator shield	1	ABS
10G	Water pump	1	ABS
10H	Alternator axle	1	ABS
MM	Screws 2.3 x 4mm	2 + 1*	Iron
MP	Screws 2.3 x 4mm	3 + 1*	Iron

* Replacement screws included



01 ASSEMBLING THE ALTERNATOR

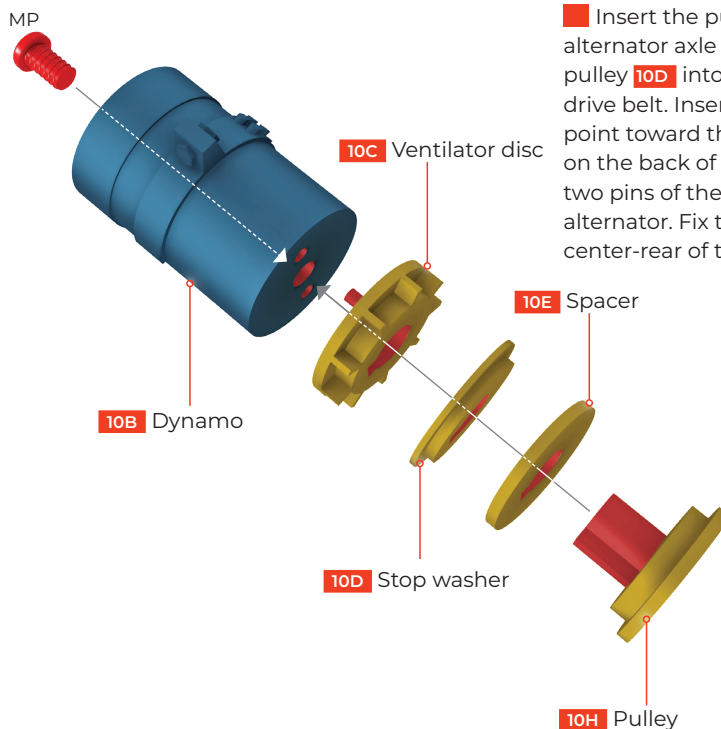

Insert the pulley spacer **10E** over the shaft of the alternator axle **10H**. Insert the narrowest side of the pulley **10D** into the shaft, so there is a groove for the drive belt. Insert the alternator fan **10C** so the blades point toward the alternator axle. Set the alternator **10B** on the back of the alternator fan **10C** by fitting the two pins of the disc into the holes in the front of the alternator. Fix the set in place with an **MP** screw in the center-rear of the alternator.

02 FITTING THE ALTERNATOR SHIELD

Line up the water pump **10G** and the alternator **10B**, as shown in the image. Check that the two pins on the side of this set are aligned with each other. Next, position the alternator shield **10F**, introducing the two aligned pins through the two holes of the plate. The alternator should be on the narrower side of the plate, as shown.

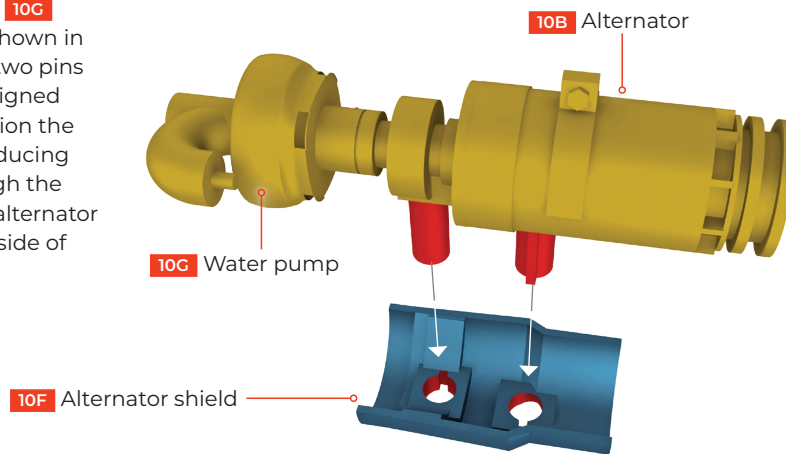

03 FIXING THE ASSEMBLY TO THE RIGHT ENGINE BLOCK

Insert the bolts of the set – alternator **10B** and water pump **10G** – into the designated holes on the right engine block **10A**. Fix the set in place with two **MP** screws.

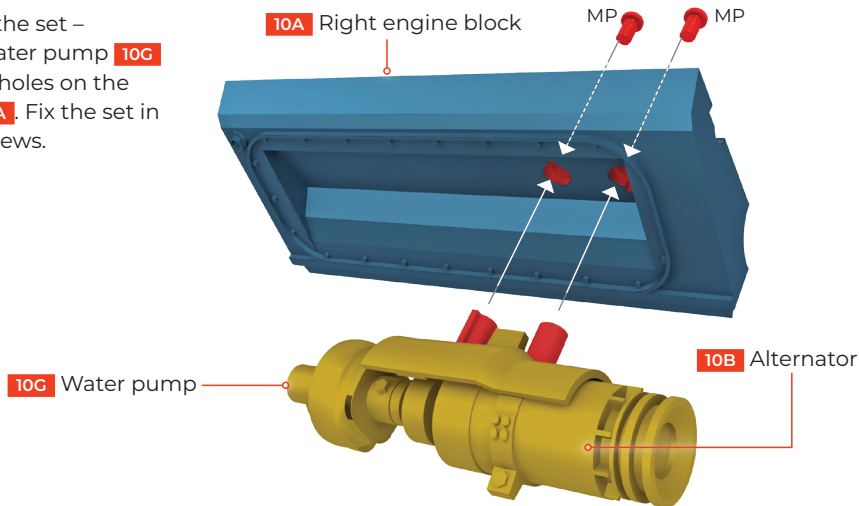

Be careful, when positioning the right engine block, not to damage the other parts of the set.

04 ASSEMBLING THE ENGINE BLOCKS

Take the left engine block assembled in stage 9, and the right engine block. Take the right engine block **10A** and slide it under the intake and exhaust manifolds until it aligns with the left engine block **04A**. Join the blocks by pressing them together. Fix them in place with two **MM** screws (Fig. 1).

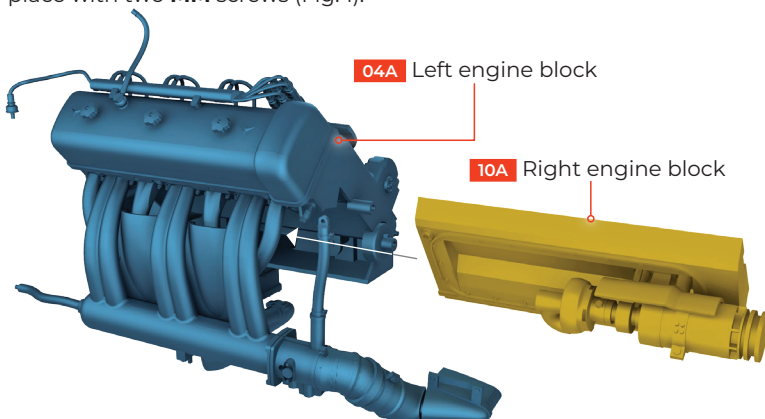

Fig. 1

