

TITANIC

THE SHIP • THE LEGEND

Pack 14





SERVICE AREA AND CORRIDOR

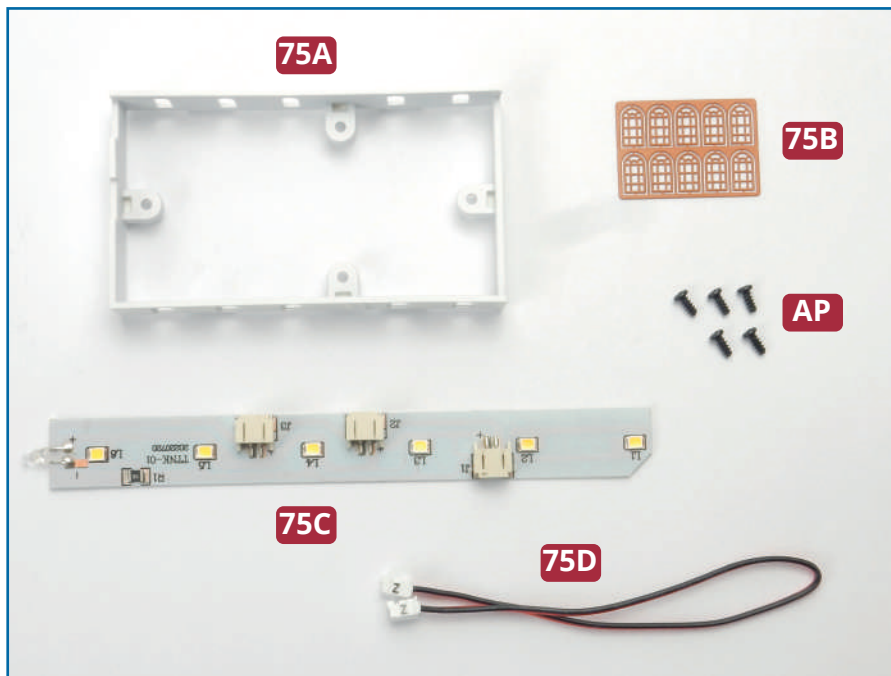

PARTS IN THIS ISSUE

75A Service and corridor superstructure

75B Windows (x 10)

75C LED strip

75D LED cable

AP Five PB screws (1 spare)

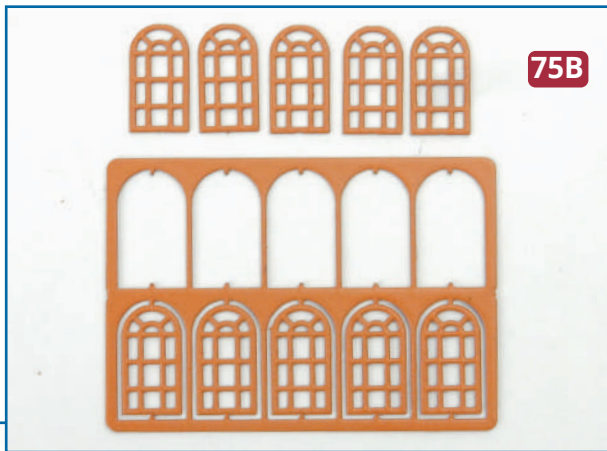

1 Remove five of the windows from the frame **75B**. Identify the window openings on the port side of part **75A** and glue the windows in place.

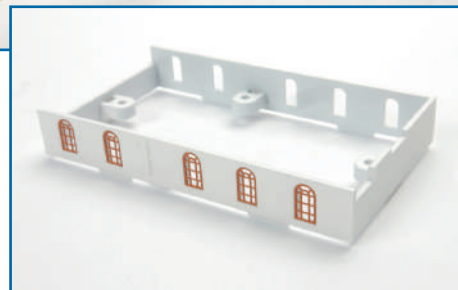
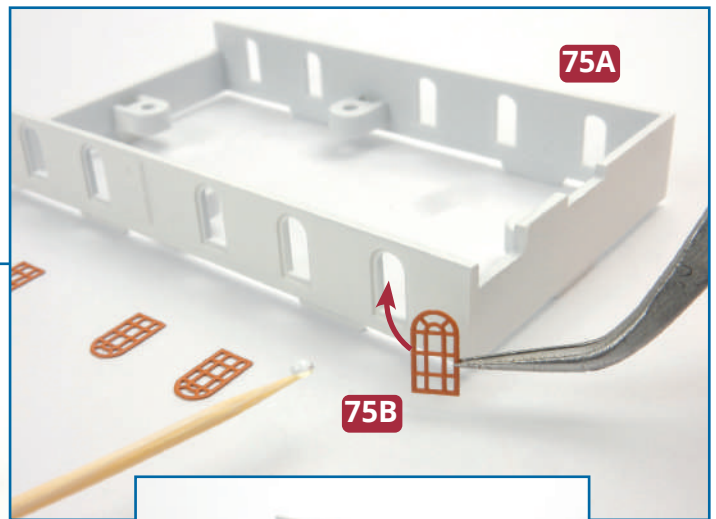
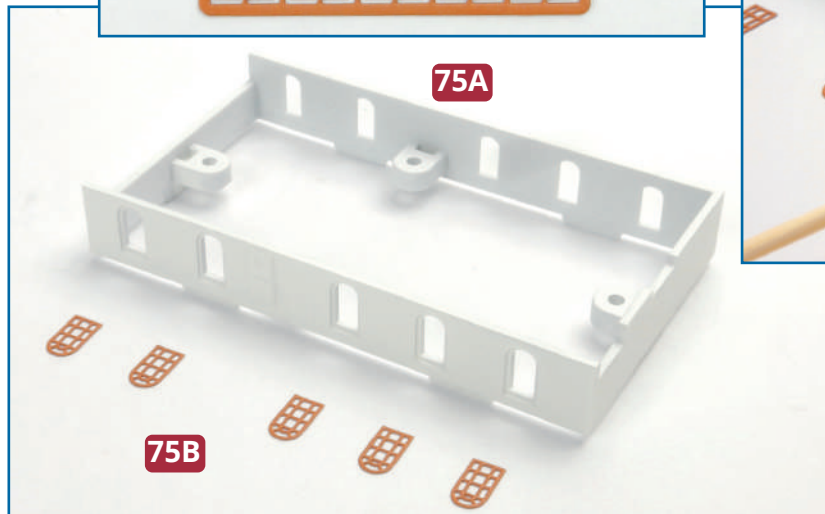



2 Remove the five remaining windows from the frame **75B**. Glue them in the openings on the starboard side of part **75A**, where the cloakroom and other service areas are located.

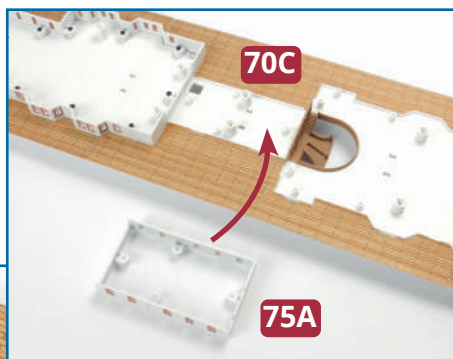
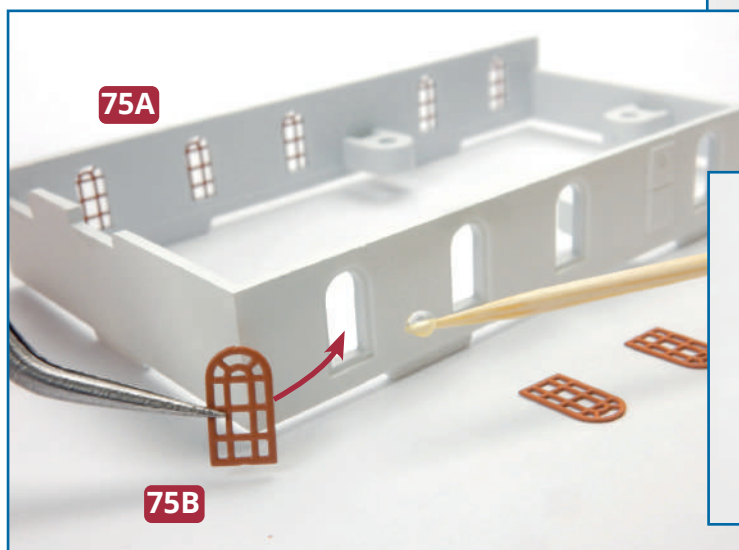
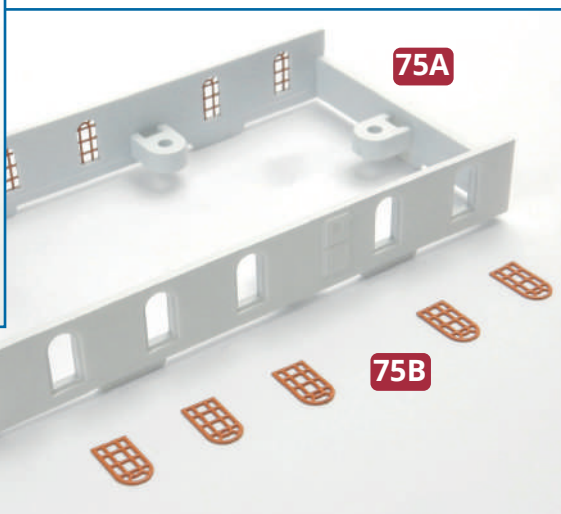
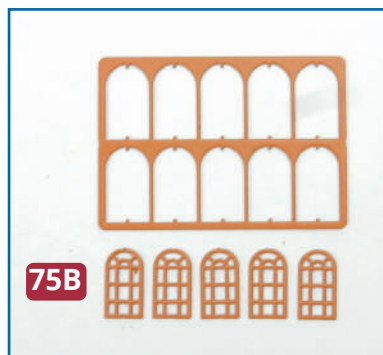

3 Position the service area **75A** on the third section of the promenade deck **70C**. With the screw holes aligned (indicated in blue, below left), use four **AP** screws to fix part **75A** to the deck (circled in red, below).

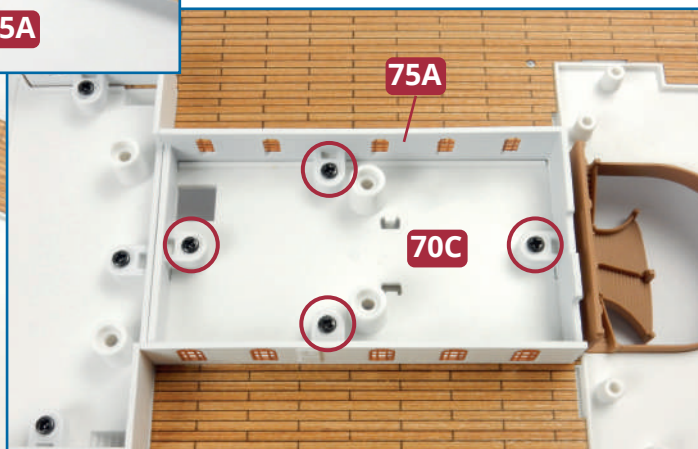
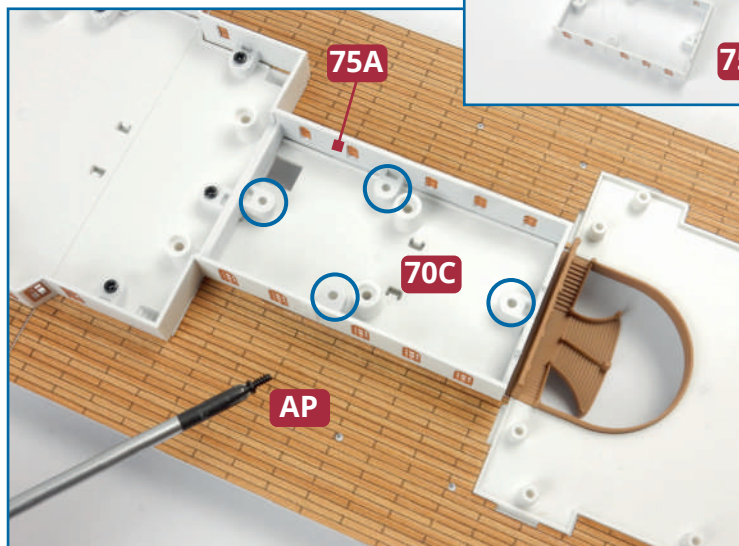



4 Carefully turn the promenade deck over and identify the position for the LED strip **75C** across the join between deck sections **70C** and **71B** (as indicated, right). Fit one side of the strip under the tabs (circled, below) and then clip the other side in place.

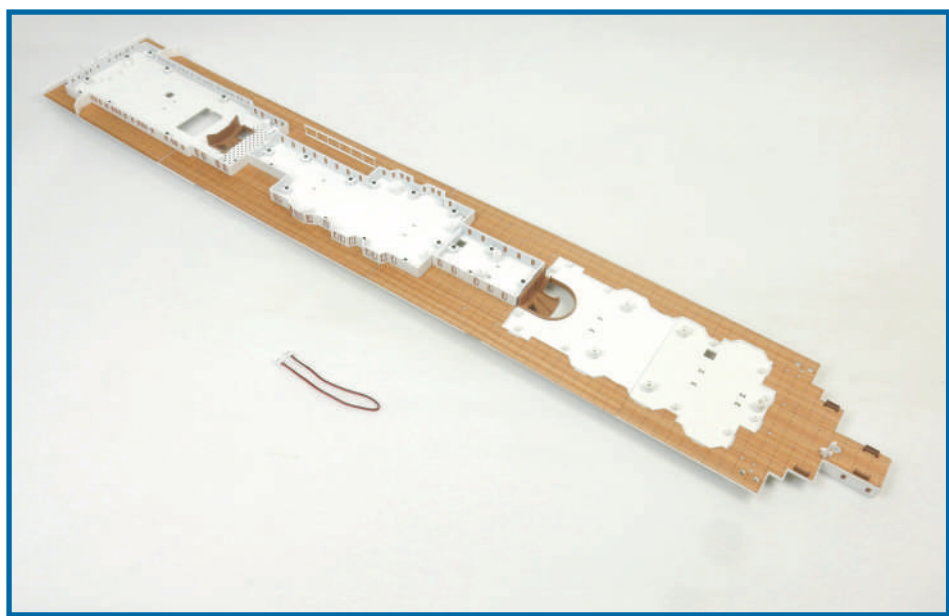
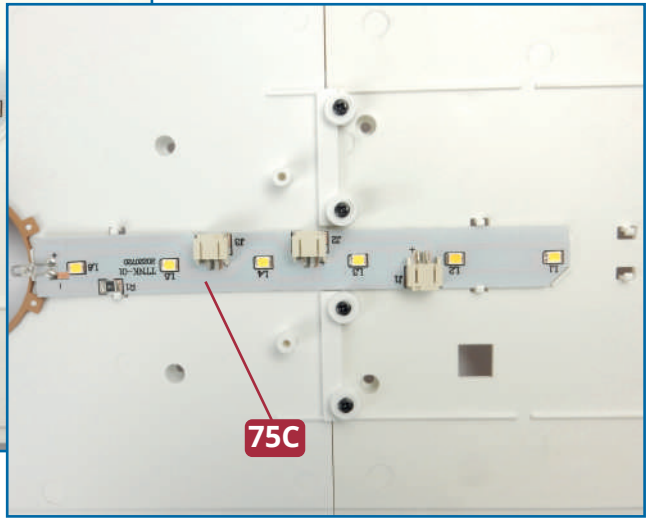
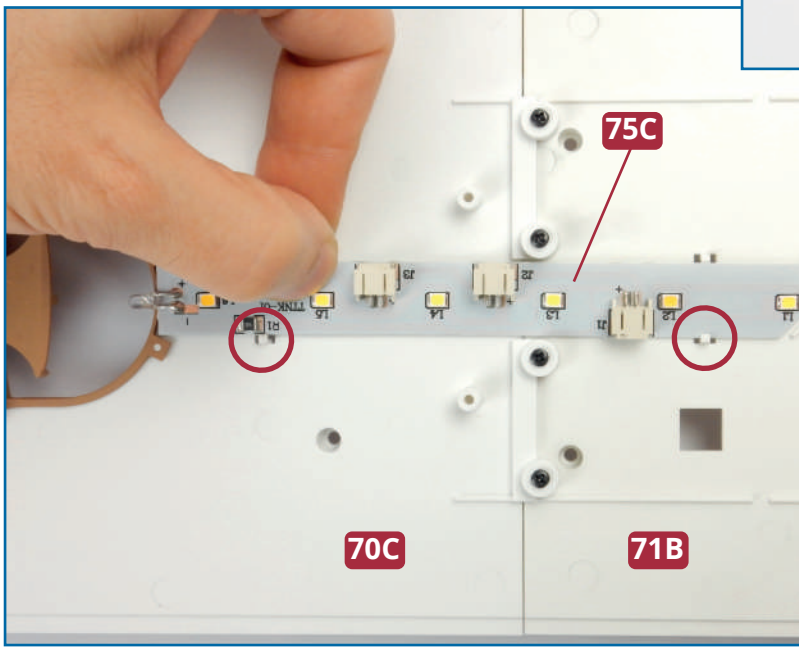
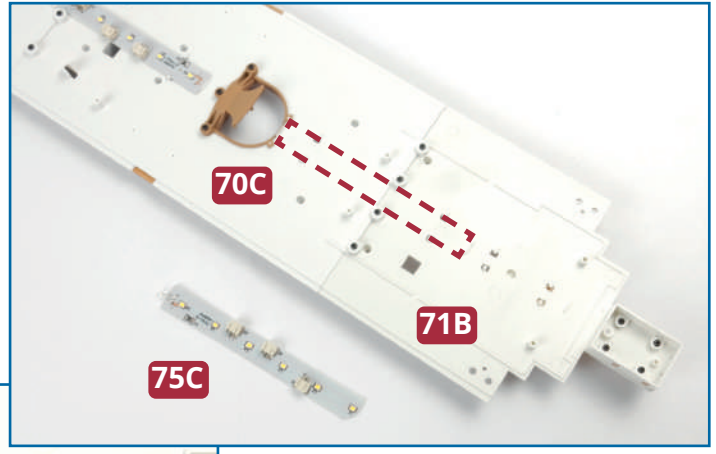

Completed work

The service area (with corridor) and LED strip have been fitted to the promenade deck. The LED cable **75D** will be fitted in the next issue.



FIRST-CLASS SMOKING ROOM

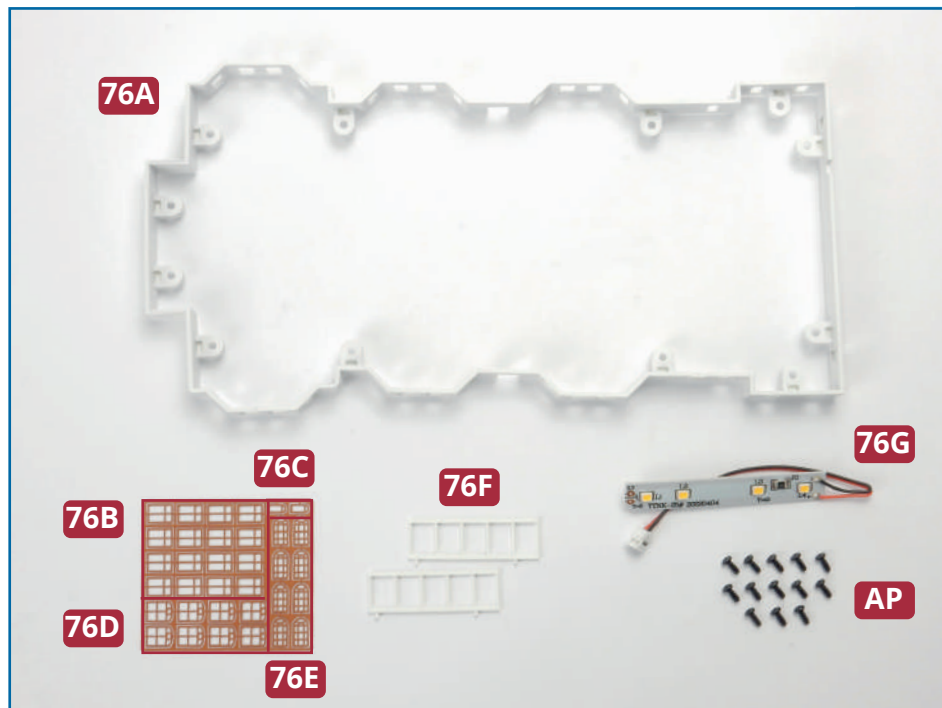

PARTS IN THIS ISSUE

- 76A** First-Class Smoking Room
- 76B** Large windows A (x 16)
- 76C** Small windows A (x 2)
- 76D** Large windows B (x 8)
- 76E** Small windows B (x 8)
- 76F** Support frames (x 2)
- 76G** LED Strip
- AP** Thirteen PB screws (1 spare)

1 Remove all 16 large windows A **76B** from the frame. Identify the openings where they fit on the side walls of the first-class smoking room (8 on each side). Glue the windows in place.

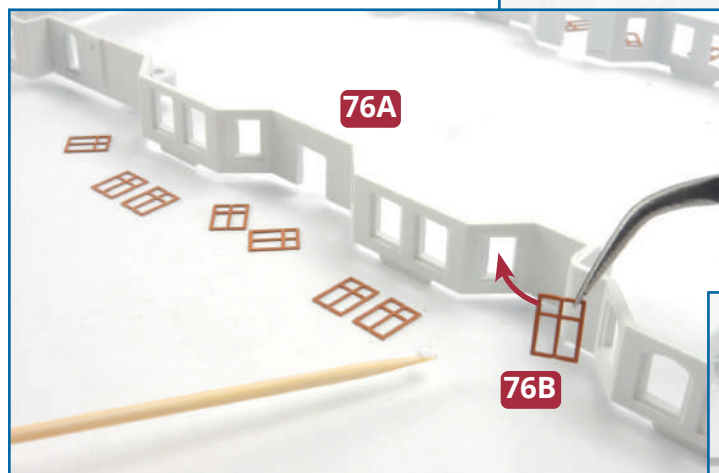
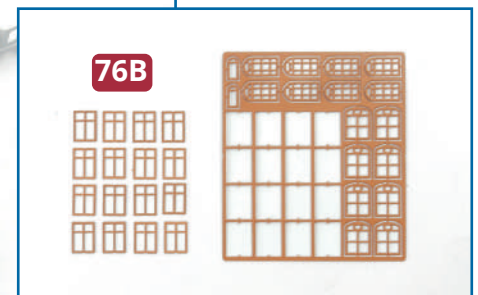
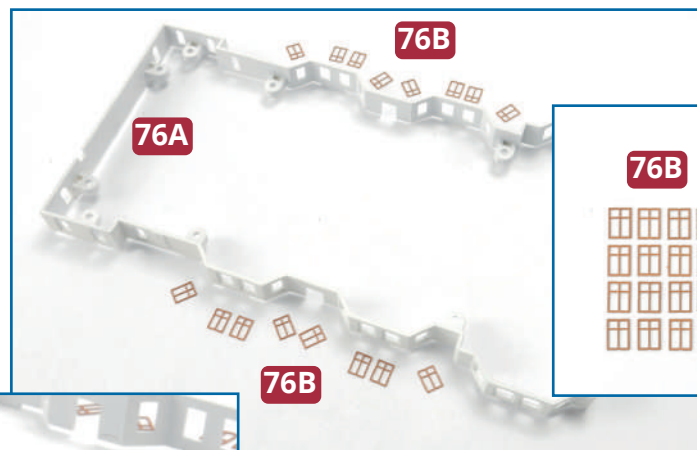

★ STEP-BY-STEP INSTRUCTIONS ★

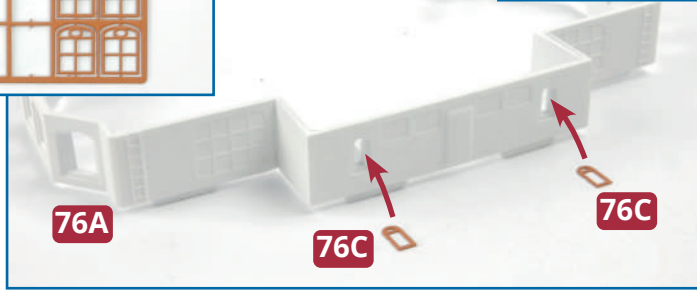
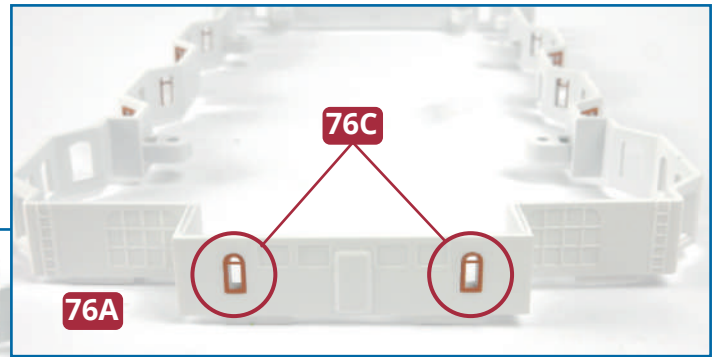
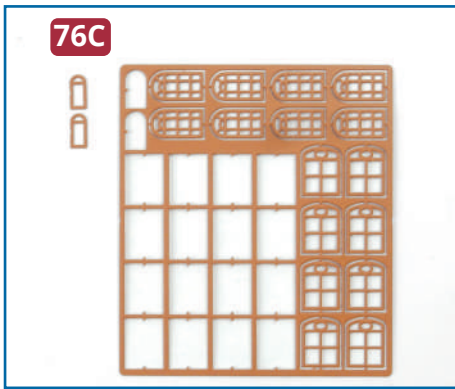

2 Remove the two small windows **76C** from the frame. Identify the openings where they fit on the aft wall of the smoking room **76A**. Glue them in place.

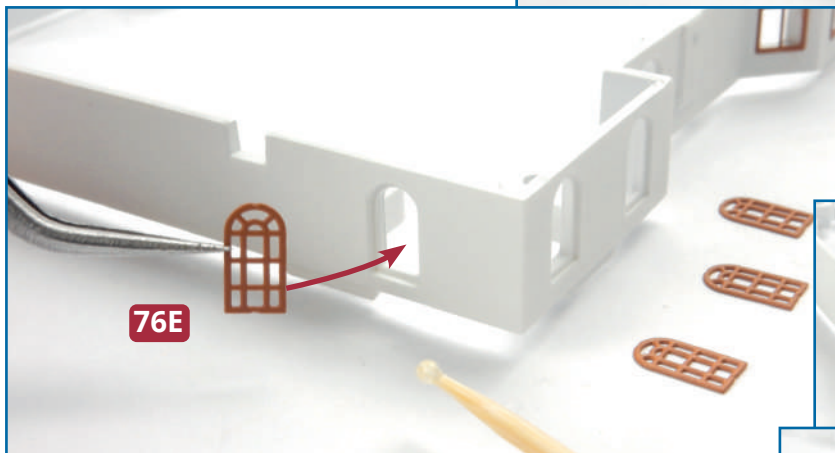
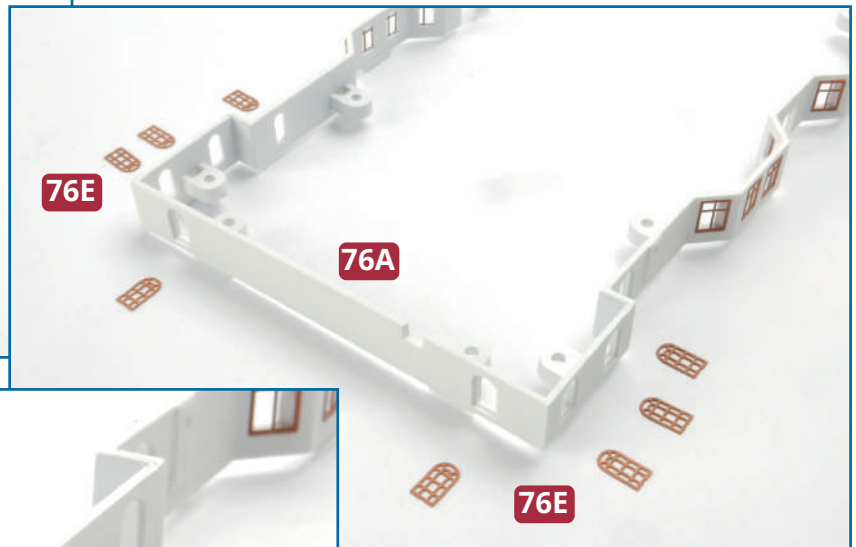
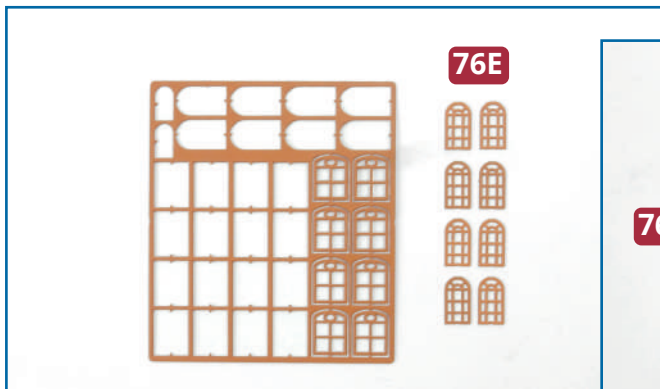

3 Remove the eight small windows **76E** from the frame. Glue them in place in the openings at the front of the smoking room **76A**, as shown.



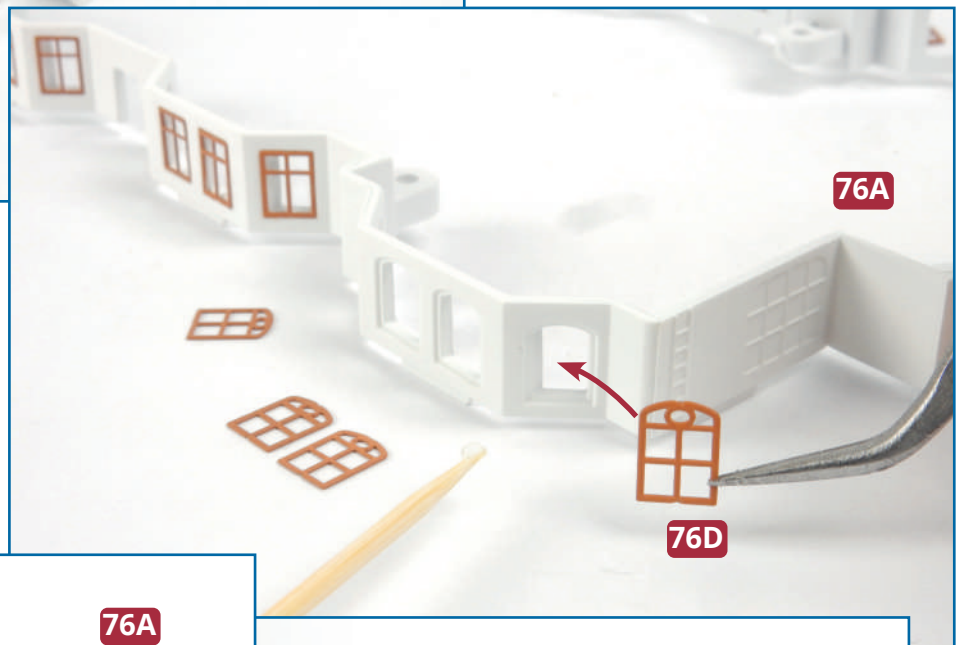
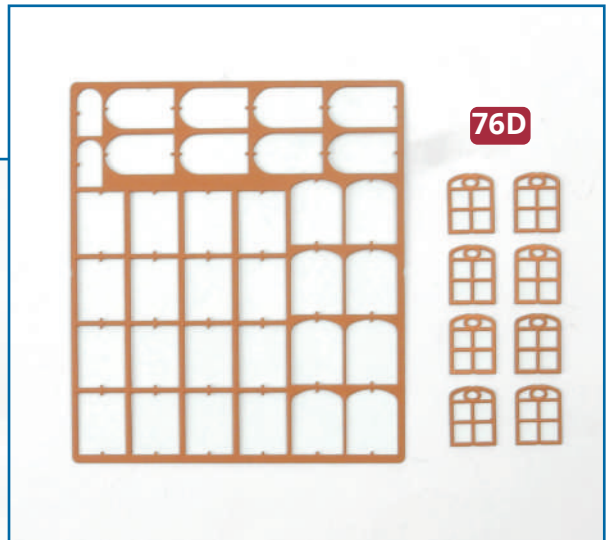
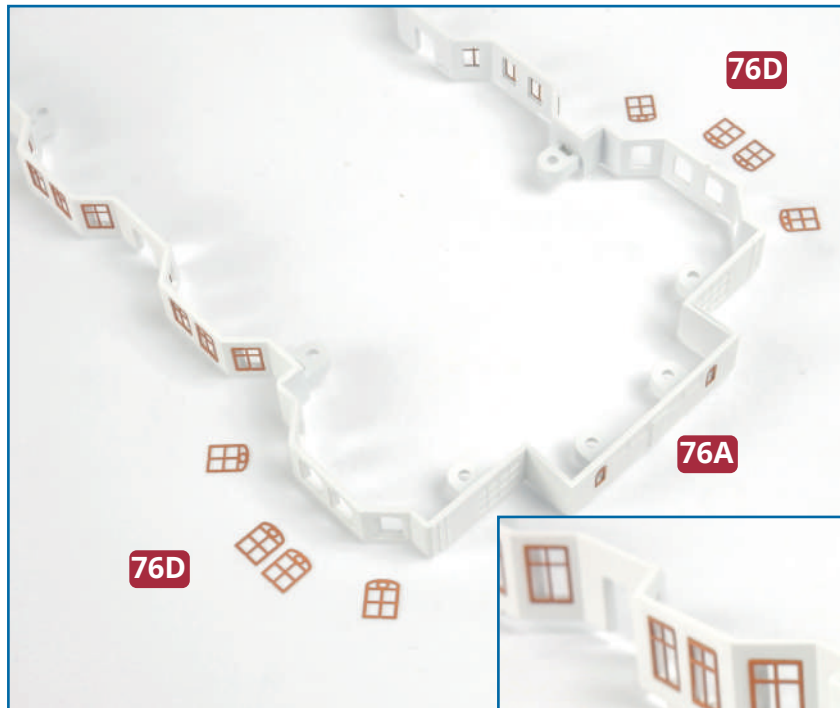

4 Remove the 8 large windows B (76D) from the frame and glue them, 4 on each side as indicated above, in the openings in the Verandah Café 76A, which is adjacent to the first-class smoking room. Make sure you have the windows the right way up.



★ STEP-BY-STEP INSTRUCTIONS ★

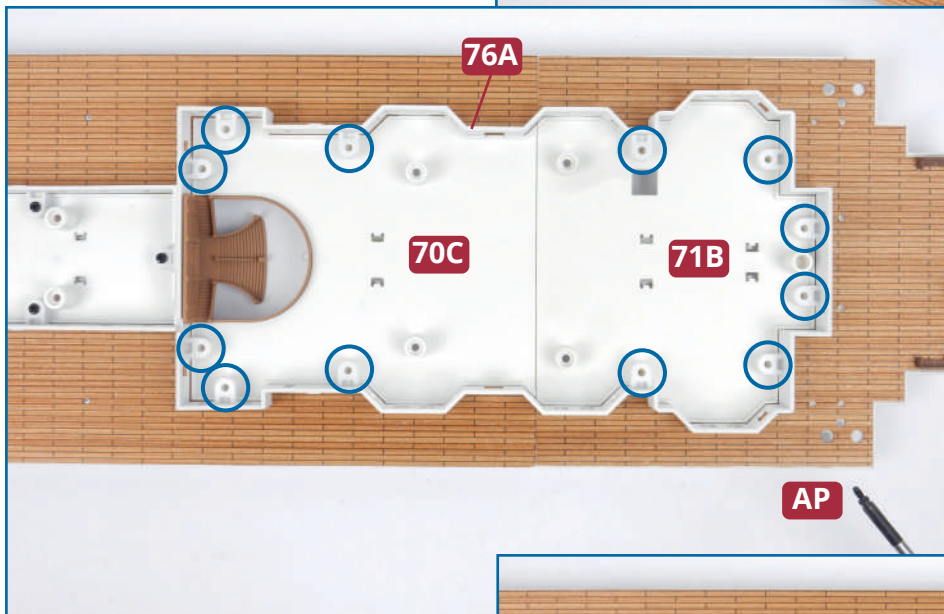
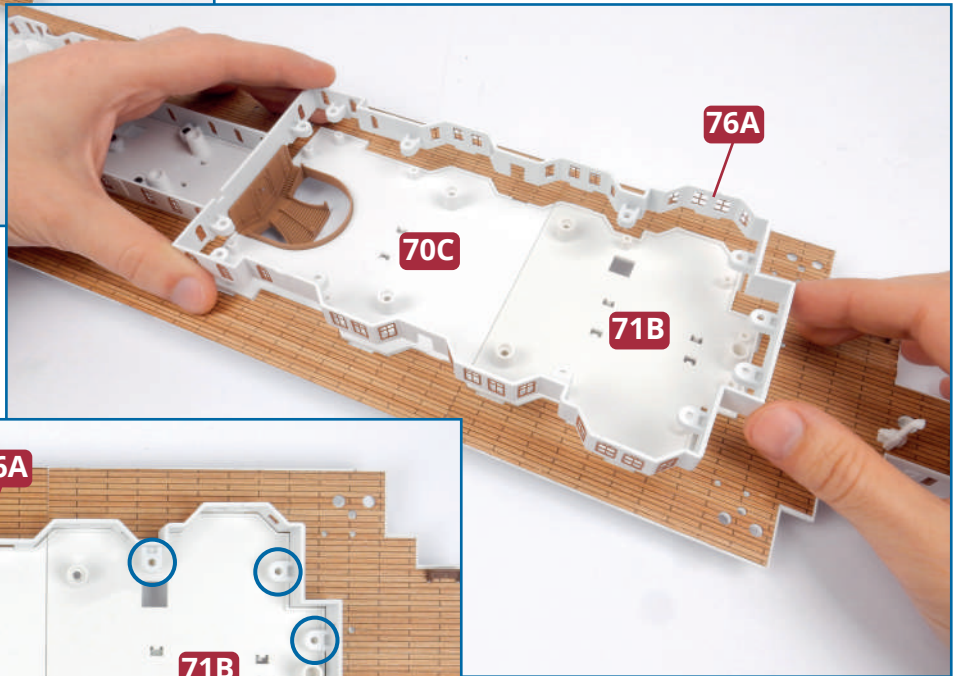
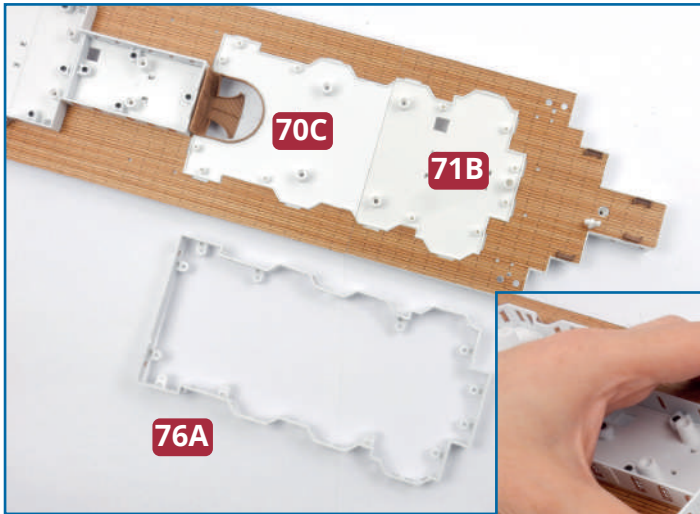

5 Position the first class smoking room assembly **76A** on the aft section of the promenade deck (sections **70C** and **71B**). With the screw holes aligned (circled in blue, above), fix the smoking room in place with twelve **AP** screws (circled, right).

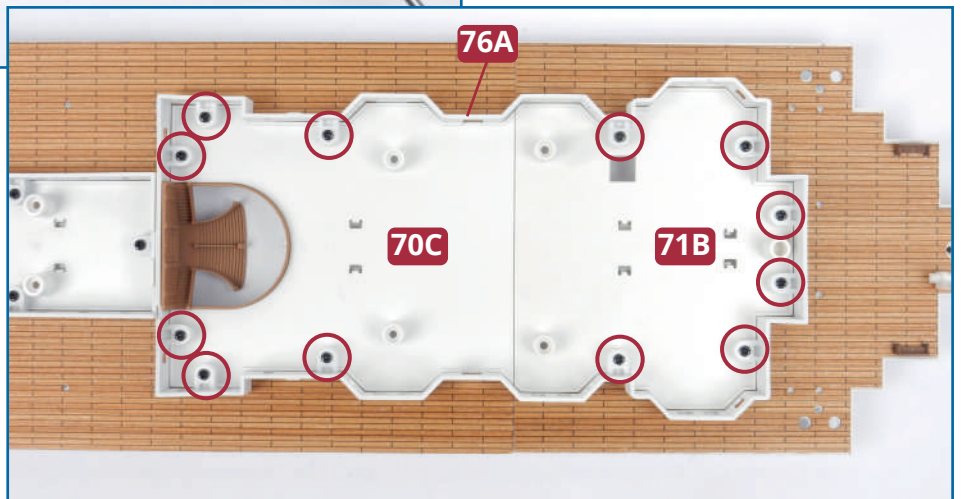

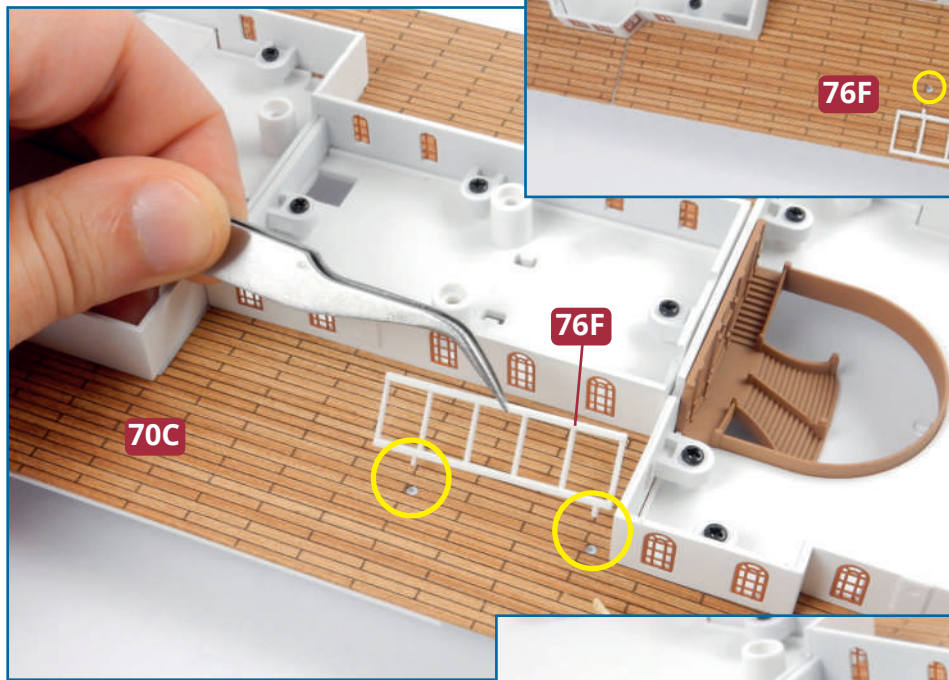
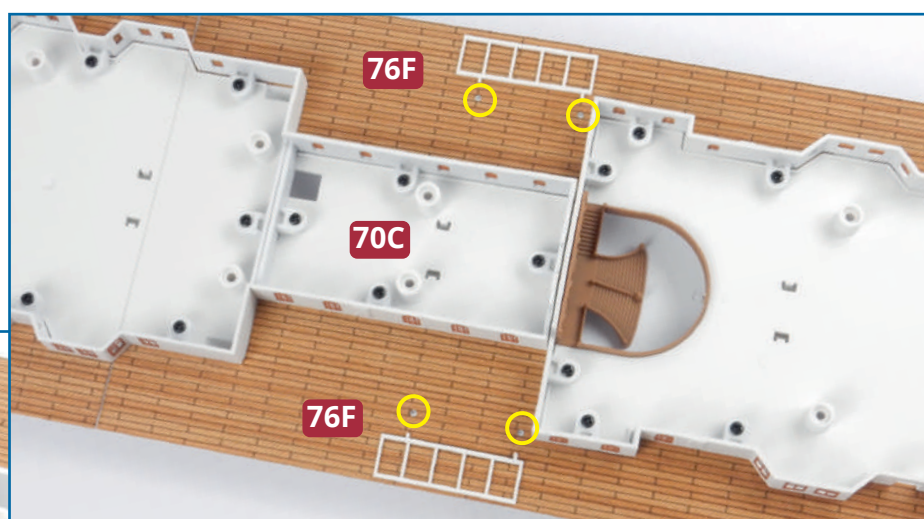

6 Take the two support frames **76F**. Identify the fixing positions: small pegs on the bottom of the frames fit into holes in the deck as indicated. Glue in place.

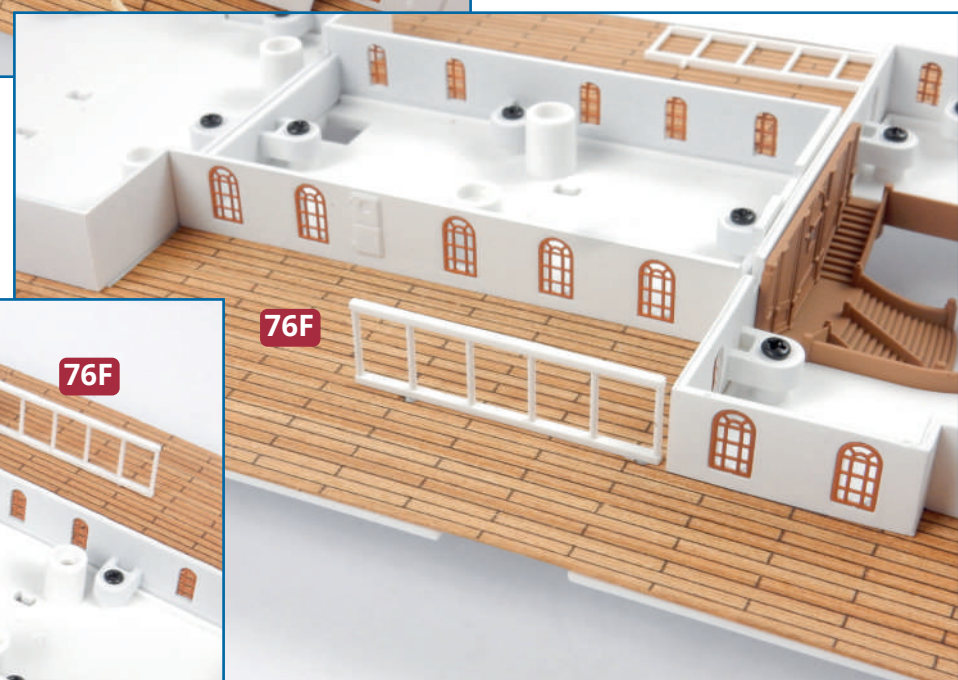

★ STEP-BY-STEP INSTRUCTIONS ★

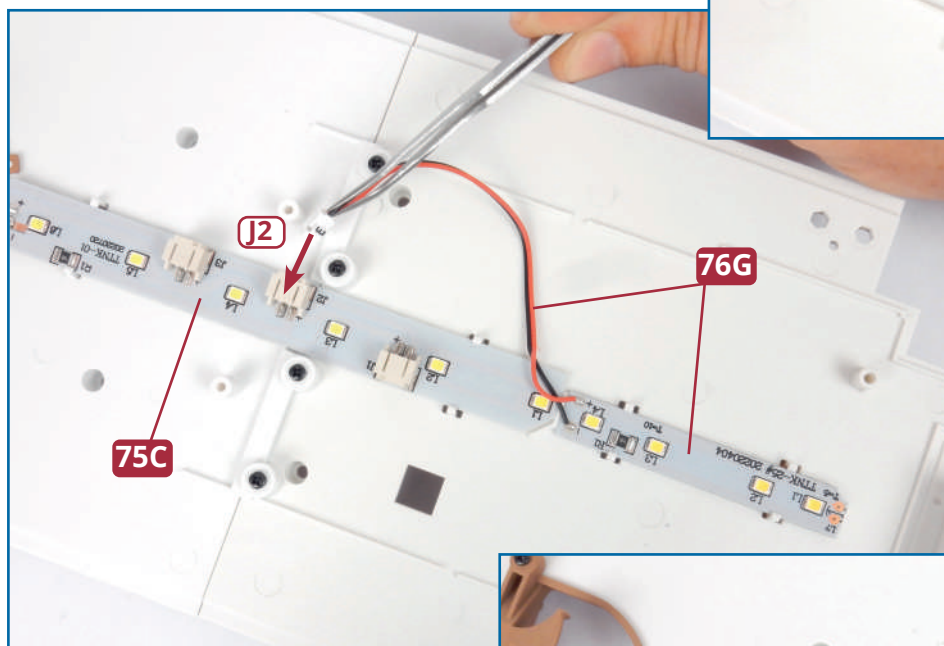
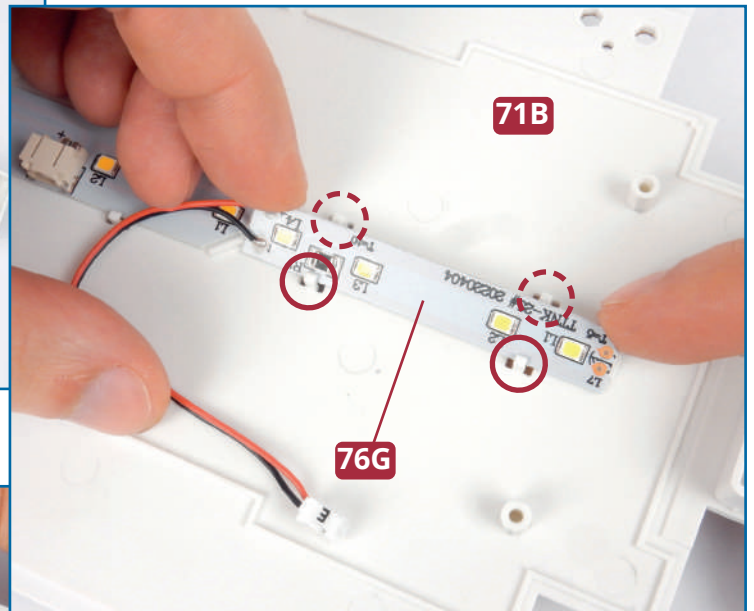
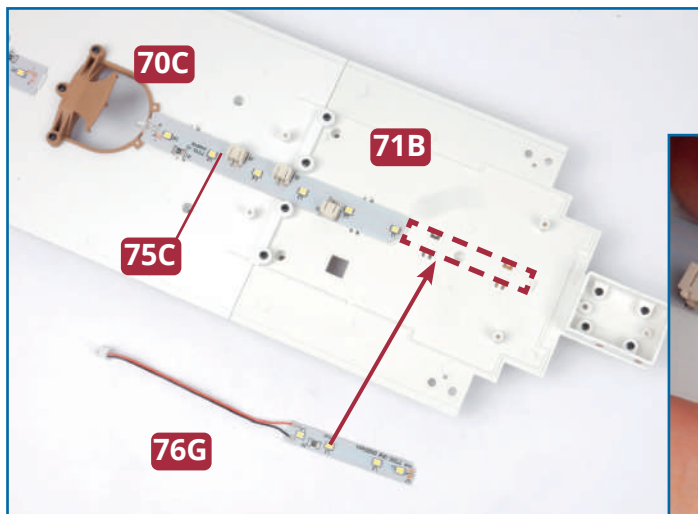

7 Carefully turn the promenade deck over and identify the fixing point for the LED strip **76G** on the underside of deck section **71B**. Fit one edge of the strip beneath the tabs (circled, top right) on the underside of the deck and then clip the other side in place.

Connect the cable **76G** to socket **J2** in the LED strip **75C**.

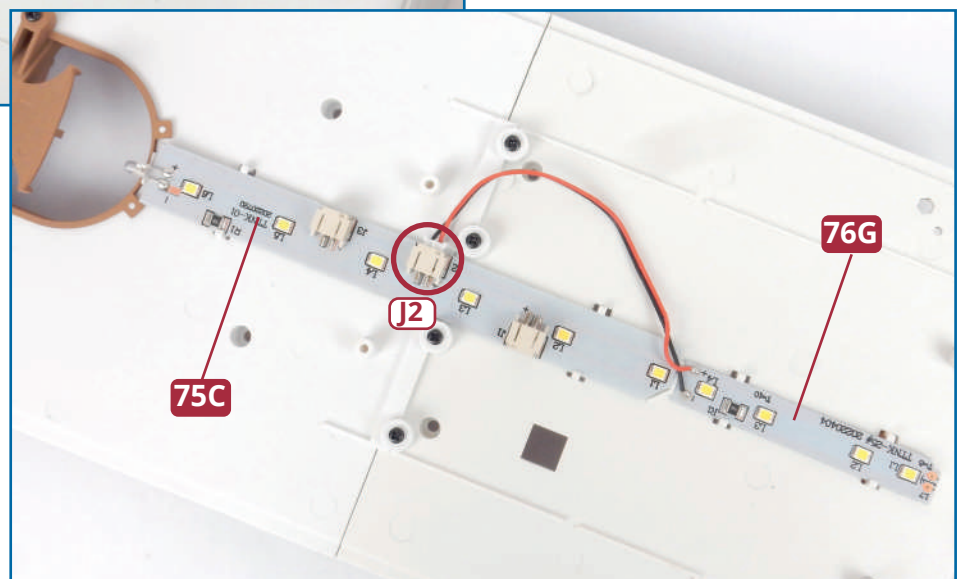

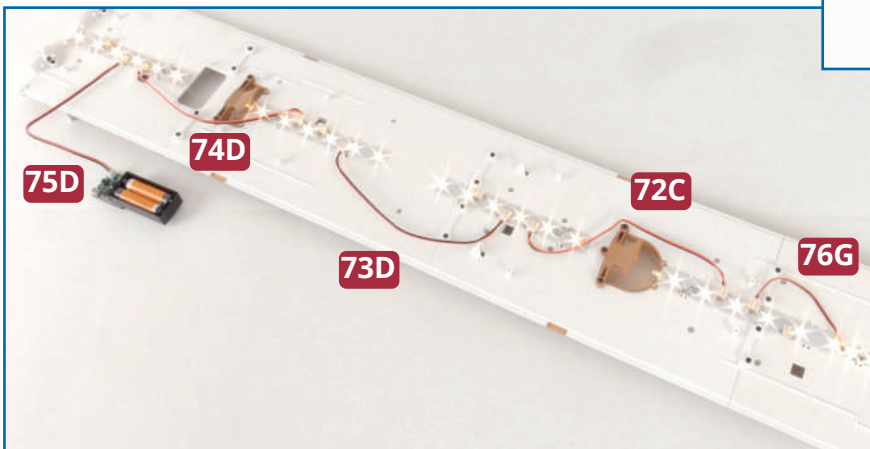
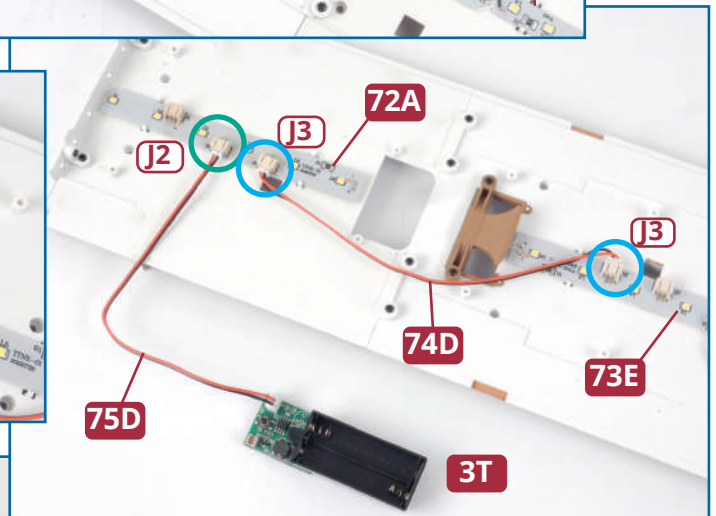
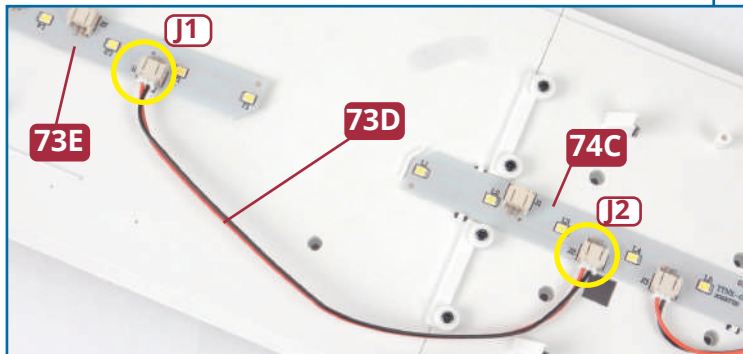
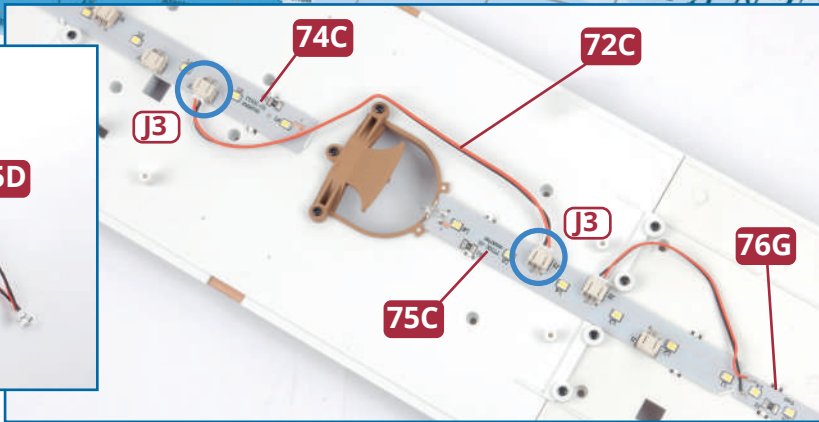
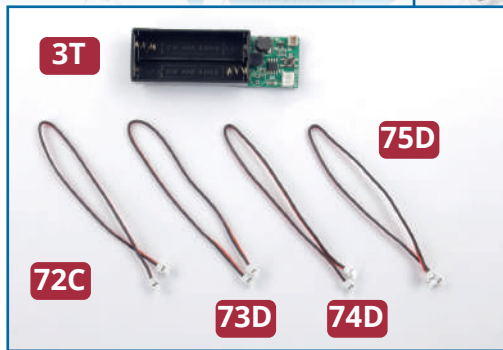

8 Take the tester (**3T**) and the four LED cables **72C**, **73D**, **74D** and **75D** supplied with previous issues. Use the cables to connect the LED strips together as shown: cable **72C** runs from **J3** on strip **75C** to **J3** on strip **74C**; cable **73D** runs from **J2** on strip **74C** to **J1** on strip **73E**; cable **74D** runs from **J3** on strip **73E** to **J3** on strip **72A**; and cable **75D** connects the tester to strip **72A**. Check that the lights are working.

Completed work

All the superstructures and lighting systems have been fitted to the promenade deck. Disconnect the tester and remove the batteries.

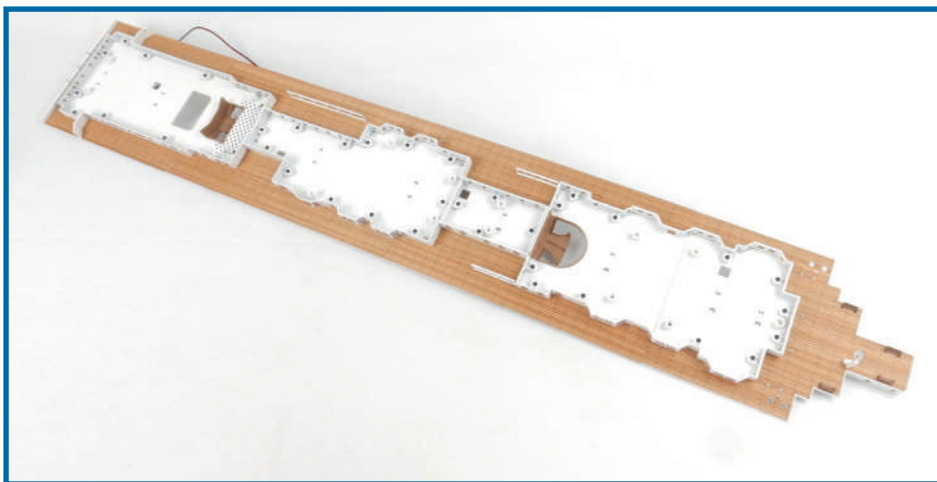

ANOTHER SECTION OF THE HULL



PARTS IN THIS ISSUE

77A Fifth hull section
(port side)

77B Washers (x 2)

LM Two 2.6 x 3mm PWM
hexagonal headed screws
(1 spare)

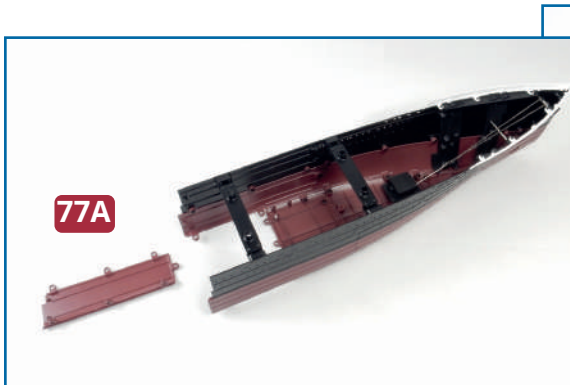

1 Take part **77A** and check how it fits against hull section **63B** on the port side of the assembly from issue 68, as shown on the left.

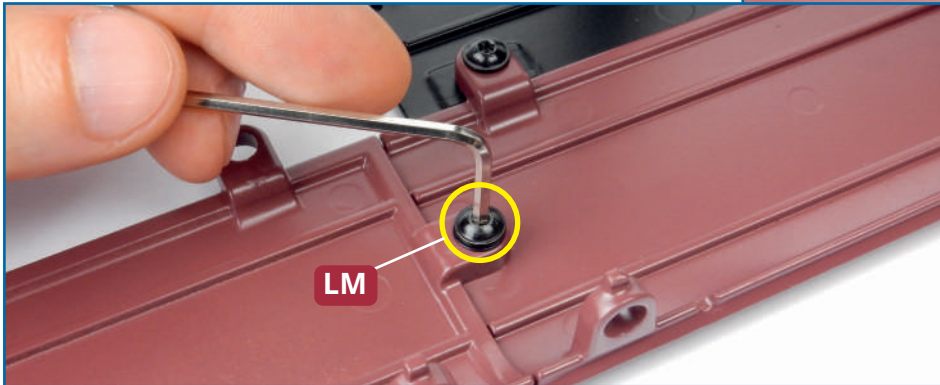
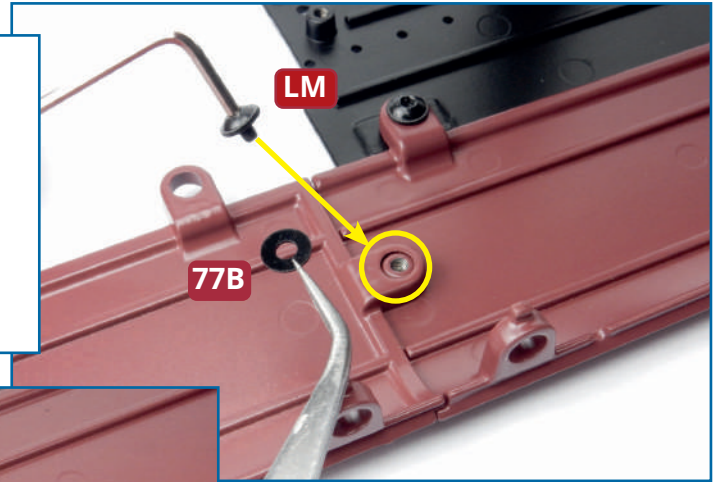
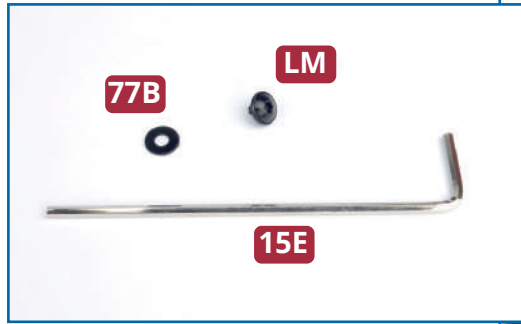

2 Fix the hull section **77A** to section **63B** with an **LM** hexagonal headed screw. If you cannot tighten the screw fully, use a washer **77B** to give extra thickness so that the fastening is more secure. To tighten the screw, use the Allen key supplied with issue 15.

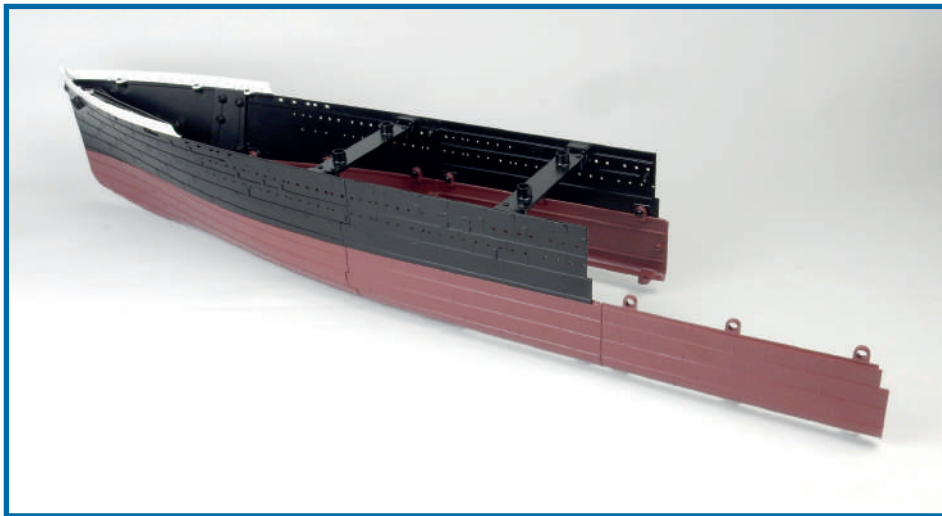

Completed work

Another panel has been added to the port side of the hull.

THE NEXT UPPER HULL SECTION

78A



78B



LM

PARTS IN THIS ISSUE

78A Upper hull section
(port side)

78B Washers (x 5)

LM Five hexagonal headed
PM screws (1 spare)

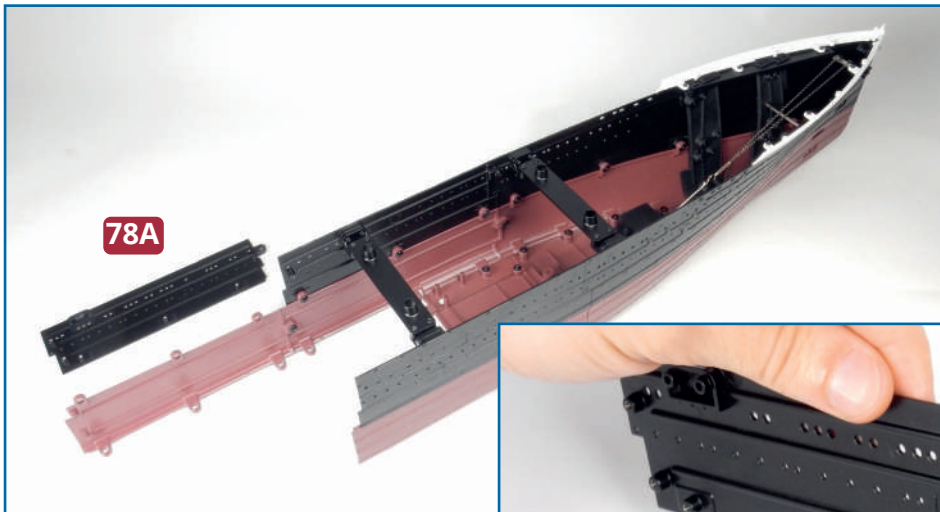

1 Take the next section of the hull **78A** and position it on the port side as shown above: The screw hole in the tab on the forward end of part **78A** aligns with the socket on part **64A** (circled in white, right) and three screw holes in tabs on the upper edge of part **77A** align with sockets on the lower edge of part **78A** (circled in yellow).

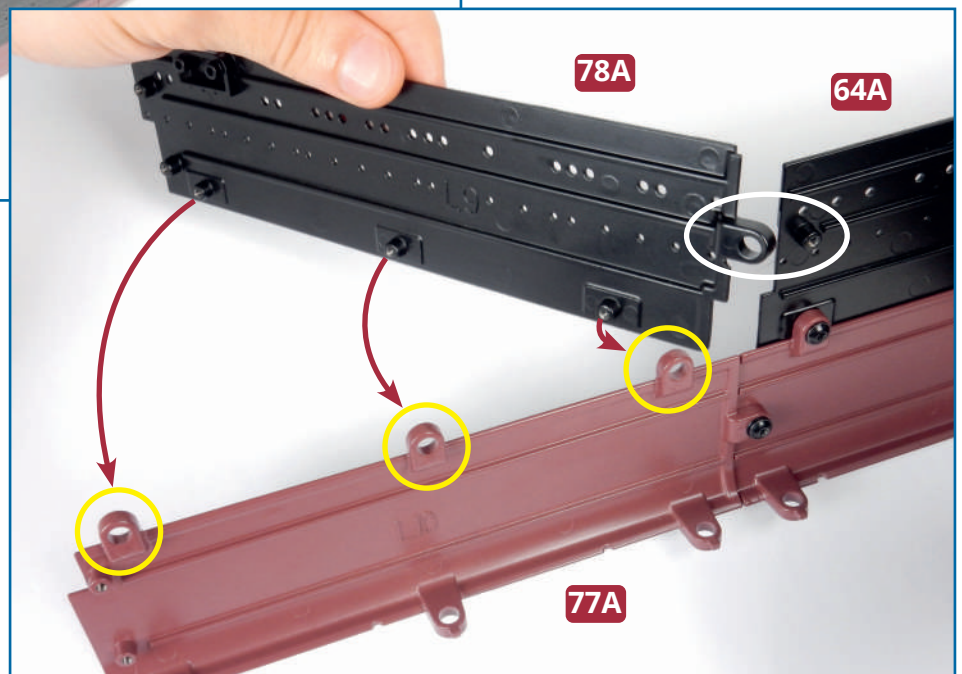

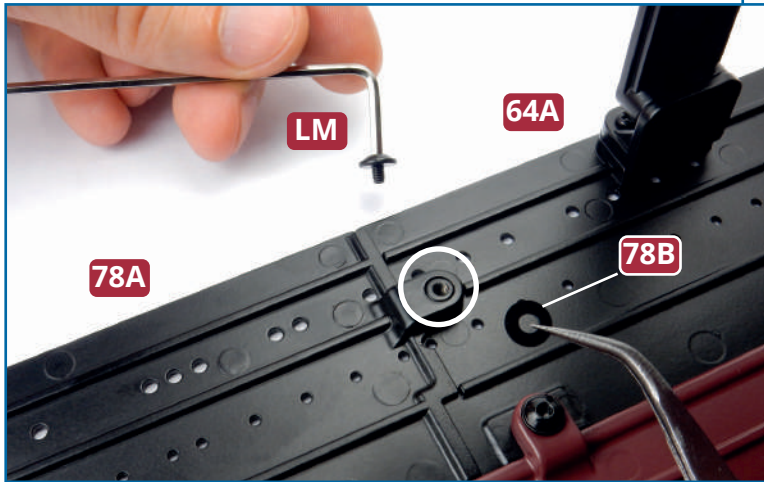

2 Fix the hull section **78A** to sections **64A** and **77A** with four **LM** hexagonal headed screws. If they do not tighten fully, you can use washers **78B** to add thickness and make the fastening more secure. Tighten the screws using the Allen key supplied with issue 15.



Completed work

The next section of hull has been fitted to the upper port side of the assembly.

THE NEXT SECTION OF STARBOARD HULL

PARTS IN THIS ISSUE

79A Starboard hull section (labelled R8)

79B Washers (x 2)

LM Two 2.6 x 3mm hexagonal headed PWM screws (1 spare)



1 Take the hull section **79A** and check how it fits against part **65A** so that the tab with the large screw hole on part **79A** fits over the raised screw socket on part **65A**, as indicated below.

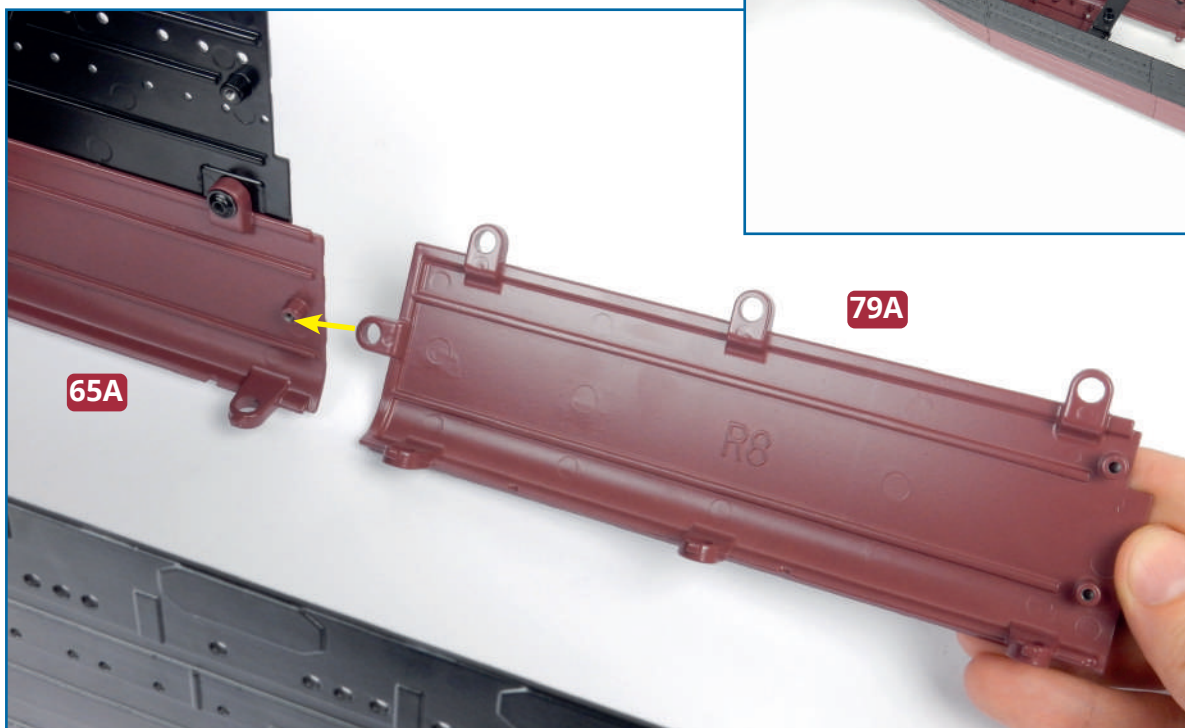

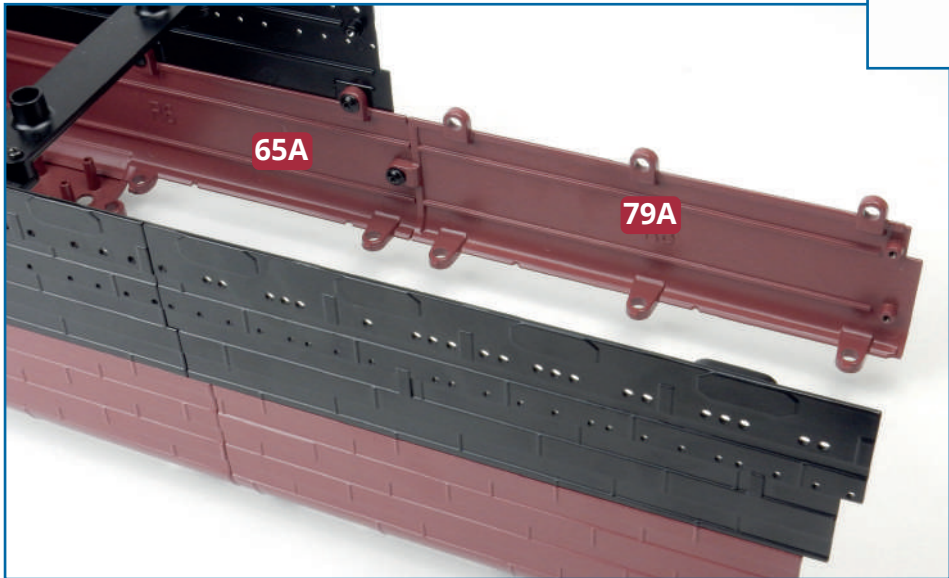
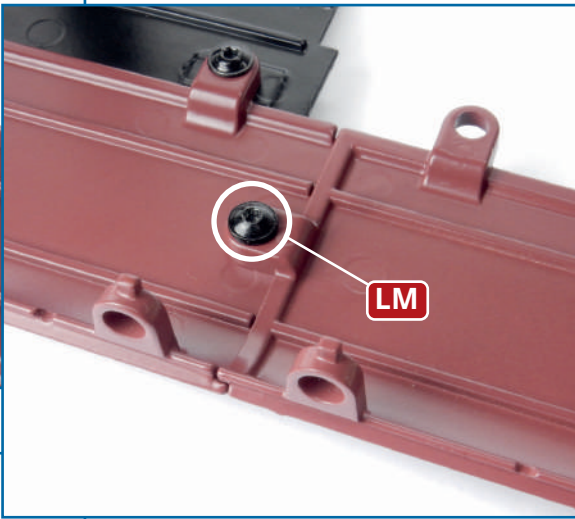
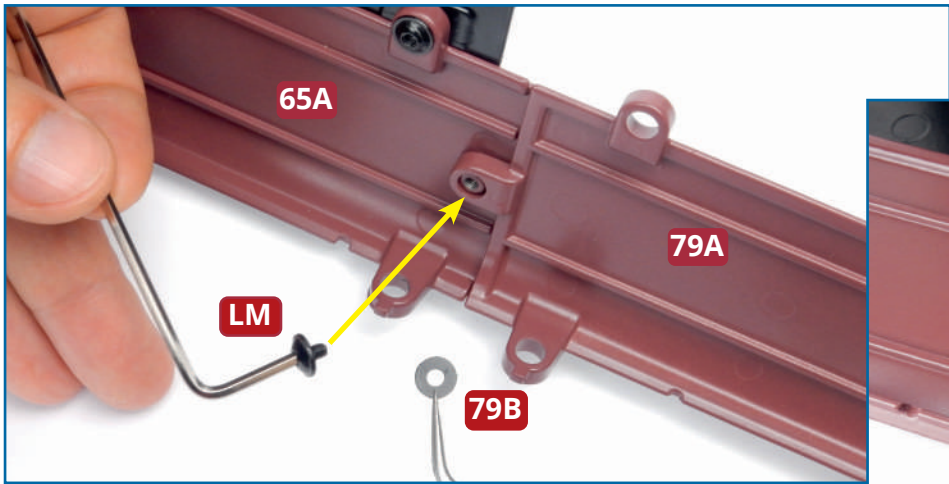

2 Fix the hull section **79A** to part **65A** section with an **LM** screw. If you have any difficulty in fully tightening the screw, you can fit a washer **79B** beneath the head of the screw to make the fastening more secure. To tighten the screw, use the Allen key that was supplied with issue 15.

Completed work

This photograph shows the assembly of the hull so far.

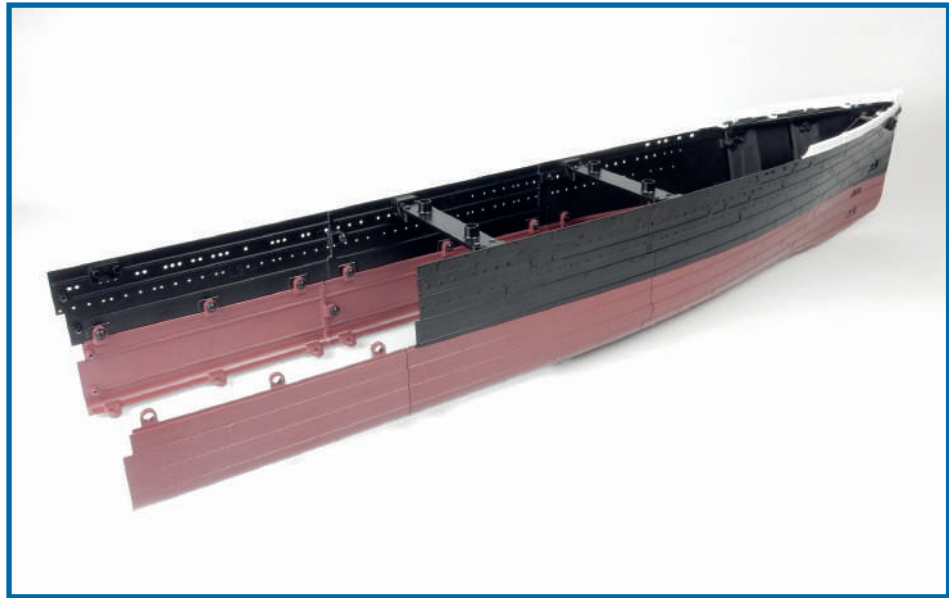

ANOTHER HULL SECTION: UPPER STARBOARD SIDE



PARTS IN THIS ISSUE

- 80A** Starboard hull section (labelled R7)
- 80B** Washers (x 5)
- LM** Five 2.6 x 3mm hexagonal headed PWM screws (1 spare)

1 Take the next upper section of the hull **80A** and position it on the starboard side so that it aligns with sections **66A** and **79A**. Make sure that the tab on the forward end of part **80A** fits over the raised screw socket on part **66A** and the screw tabs on the top of part **79A** fit over the raised screw sockets on part **80A** (circled below).

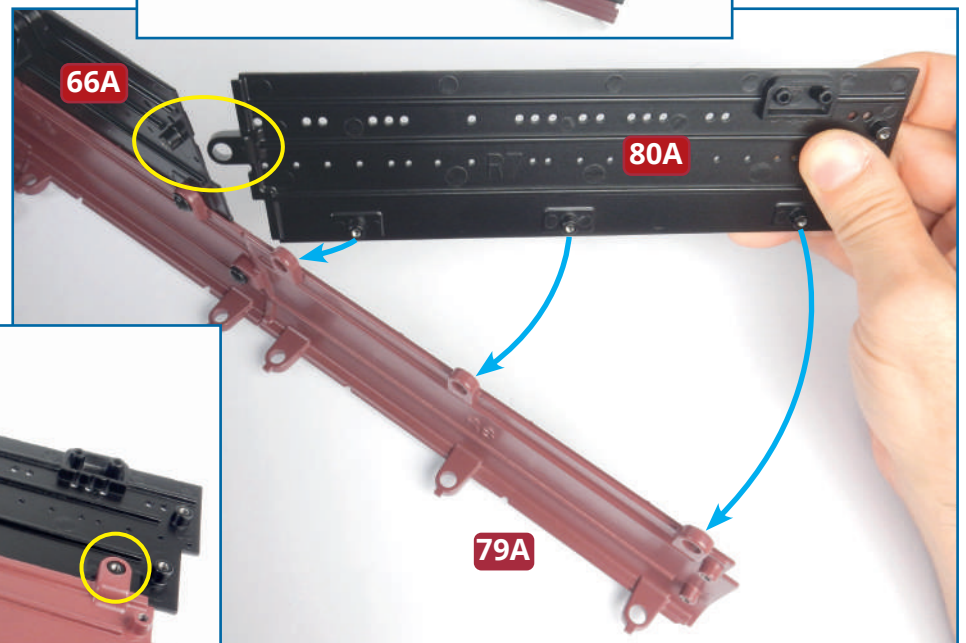
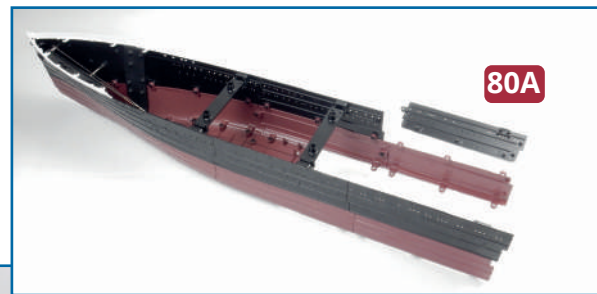

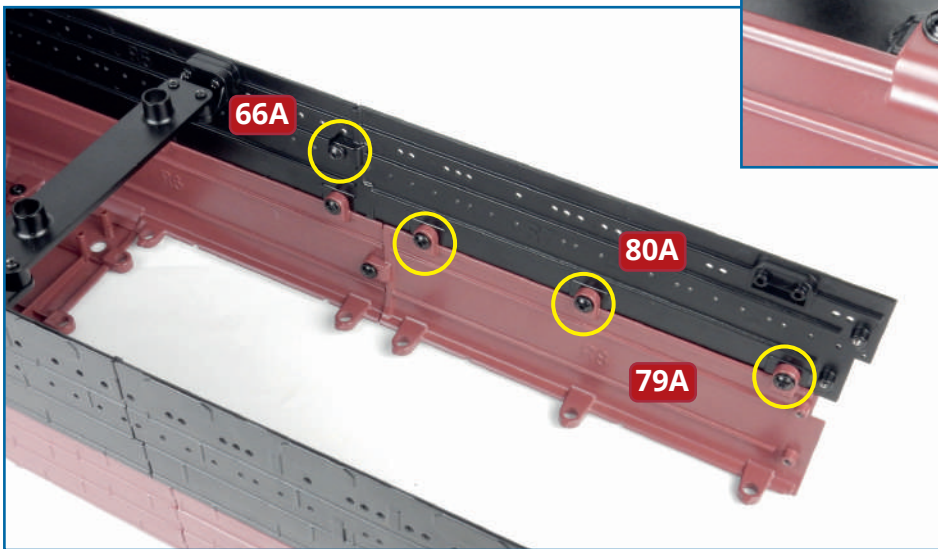
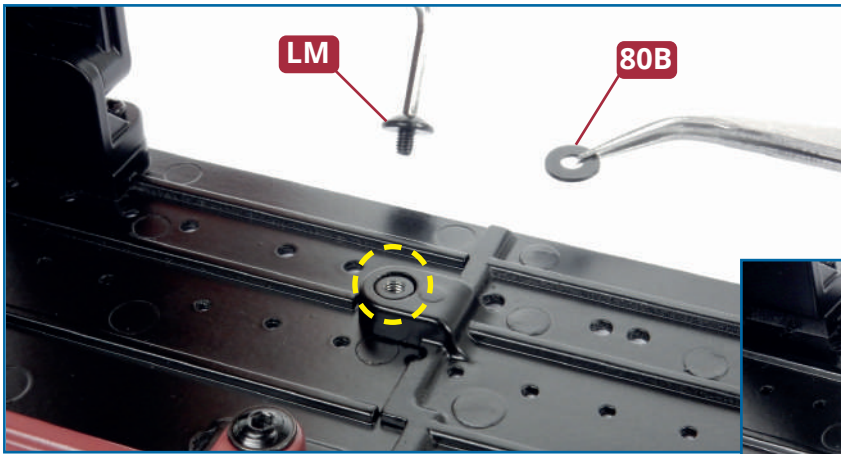

2 Fix the hull section **80A** to parts **66A** and **79A** with four **LM** screws. If you have any difficulty in fully tightening the screws, you can fit one of the washers **80B** beneath the head of each of the screws to make the fastening more secure. To tighten the screws, use the Allen key supplied with issue 15.

Completed work

This shows the hull of your model with the latest section of hull fixed in place.

