

**NO
TIME
TO
DIE** *007™*

DB5



Pack 03

BUILD INSTRUCTIONS

**STAGE 016: FITTING THE RIGHT ENGINE
BLOCK**

**STAGE 017: ATTACHING THE FAN, OIL
PUMP AND PIPES**

STAGE 018: ATTACHING THE OIL PAN

**STAGE 019: CONNECTING THE OIL
DISTRIBUTION PIPE**

**STAGE 020: FIXING THE SUSPENSION
MOUNTS**

**STAGE 021: JOINING THE FRONT AND
MIDDLE CHASSIS**

**STAGE 022: BUILDING THE RIGHT WHEEL
HUB AND FITTING THE UPPER RIGHT
CONTROL ARM**

**STAGE 023: ASSEMBLING THE FRONT
RIGHT SUSPENSION**

NO TIME TO DIE © Danjaq, LLC and Metro-Goldwyn-Mayer Studios Inc. NO TIME TO DIE, *007™* and related James Bond Indicia © 1962-2024 Danjaq, LLC and Metro-Goldwyn-Mayer Studios Inc. NO TIME TO DIE, *007™* and related James Bond Trademarks are trademarks of Danjaq, LLC. All Rights Reserved.



Aston Martin, the Aston Martin Wings logo and the model name "DB5" are trademarks owned, licensed or used by Aston Martin Lagonda Limited. All Rights Reserved.

Advice from the experts

Spare screws are included with each part. Occasionally, you may be instructed to keep spare or unused screws for a later stage. Keep these spares in a safe place and label them correctly.

Please make sure you don't mix up the screws. They look quite similar, but the threads do vary slightly. Using the wrong screws may damage the parts.

When securing parts together using multiple screws, fit each screw loosely to ensure all the parts are correctly aligned before gently tightening them firmly, but not overtight, in the order in which you placed them.

The screwdriver can be magnetized by stroking it with a magnet (fridge magnet, etc.) enabling it to hold the screws and make assembly easier.

If a screw is tight going into a metal part, do not force it as you may shear the head off. Remove it and put a tiny smear of Vaseline, soap or light oil on the thread. That will lubricate it and make it easier to drive home.

During the course of this build, you will receive many pieces that you will assemble immediately – following the instructions in the corresponding stage – and other pieces that you should store safely to one side, for use in future assembly stages.

Left and Right! When building your *No Time To Die* Aston Martin DB5, the left- or right-hand side refers to that side as if you are sitting in the car.



WARNING: Some parts are assembled using magnets. These magnets can cause serious injury if they are swallowed. Keep away from children. If you suspect a magnet has been swallowed, seek medical help straight away.

Stage 016: Fitting the Right Engine Block

For the first stage of this pack, you'll attach the oil pan mount to the right engine block then fix the block to the engine.



STAGE 016 PARTS LIST

Name
016-A Right engine block
016-B Oil pan mount
DS01 screws x5
DS25 screws x3



Stage 016: Fitting the Right Engine Block

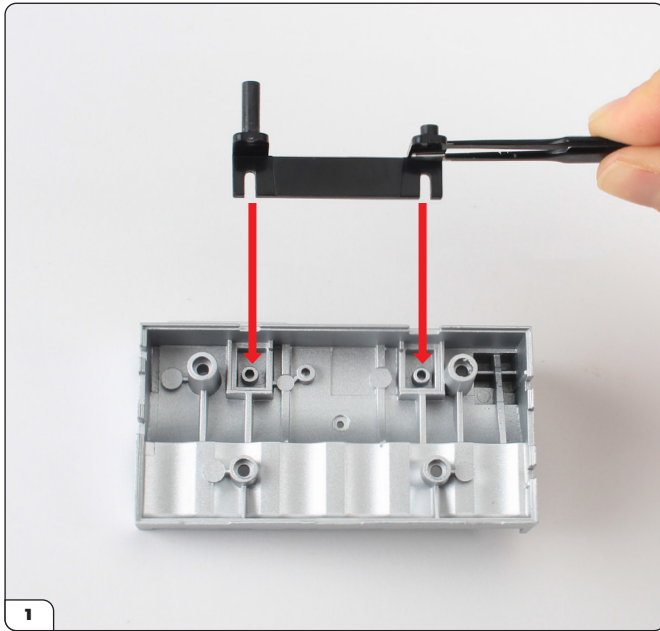

Take the oil pan mount (16-B) and align it with the right engine block (16-A). Slide the 'U'-shaped notches over the screw posts on the engine block until firmly in position.

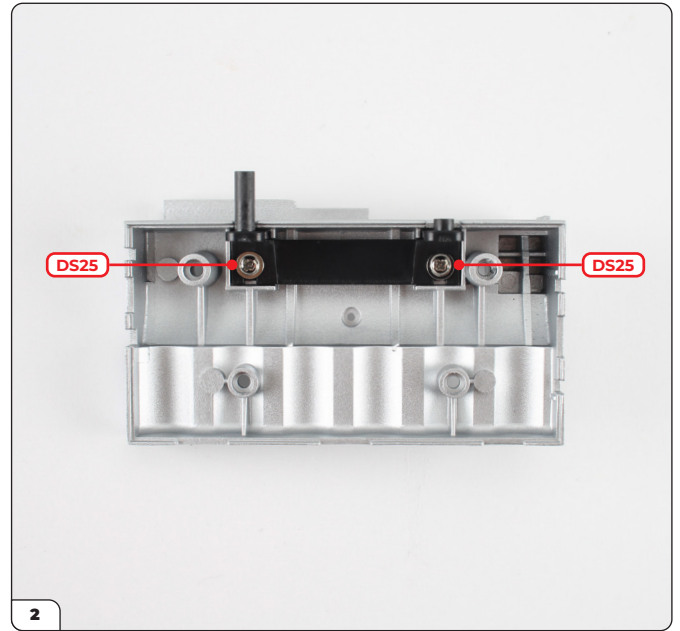

Secure in place with 2x DS25 screws.

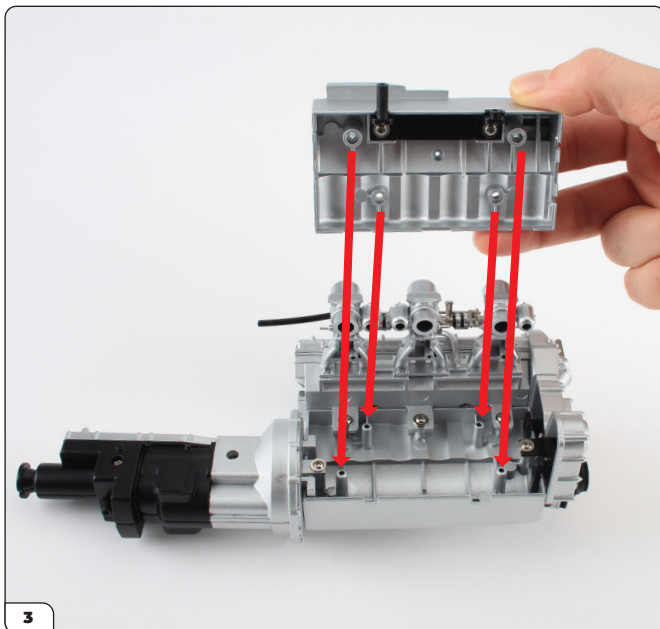

Take the engine assembly and locate the four screw columns for fitting the engine block.

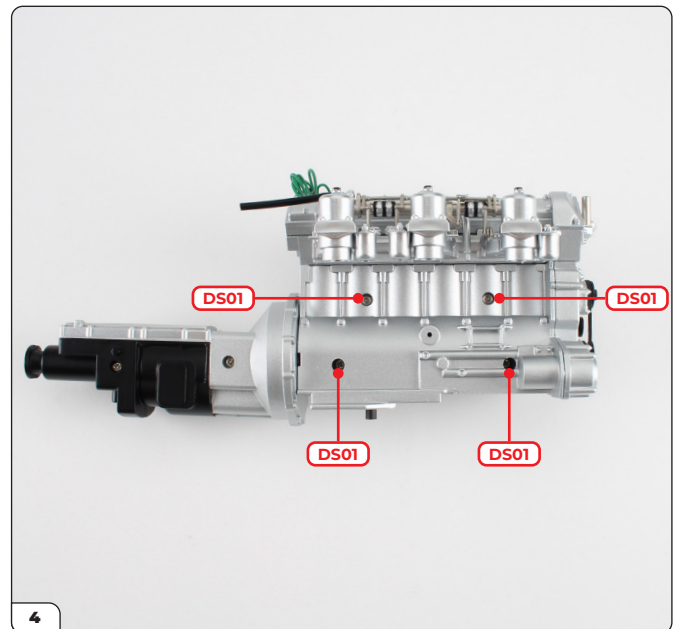

Fit the engine block in place and secure using 4x DS01 screws.

Stage 016: Fitting the Right Engine Block

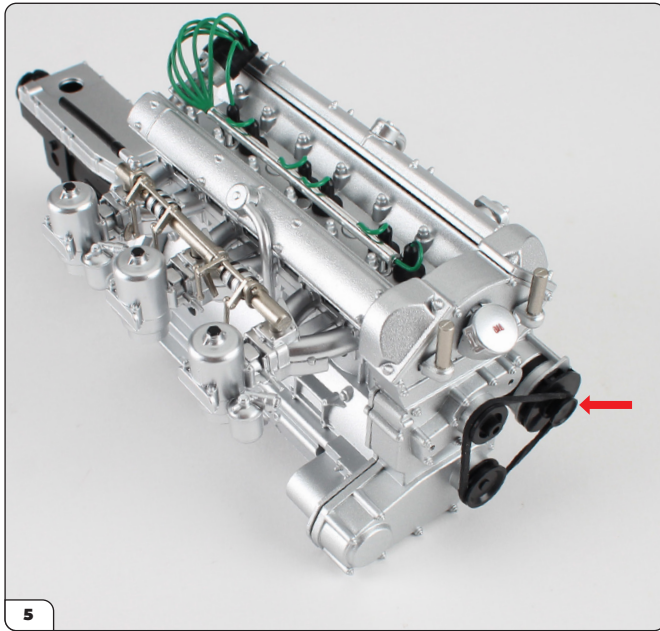

Before continuing with the next stage, check the belt is correctly assembled. It should wrap around the small pulley on the alternator.

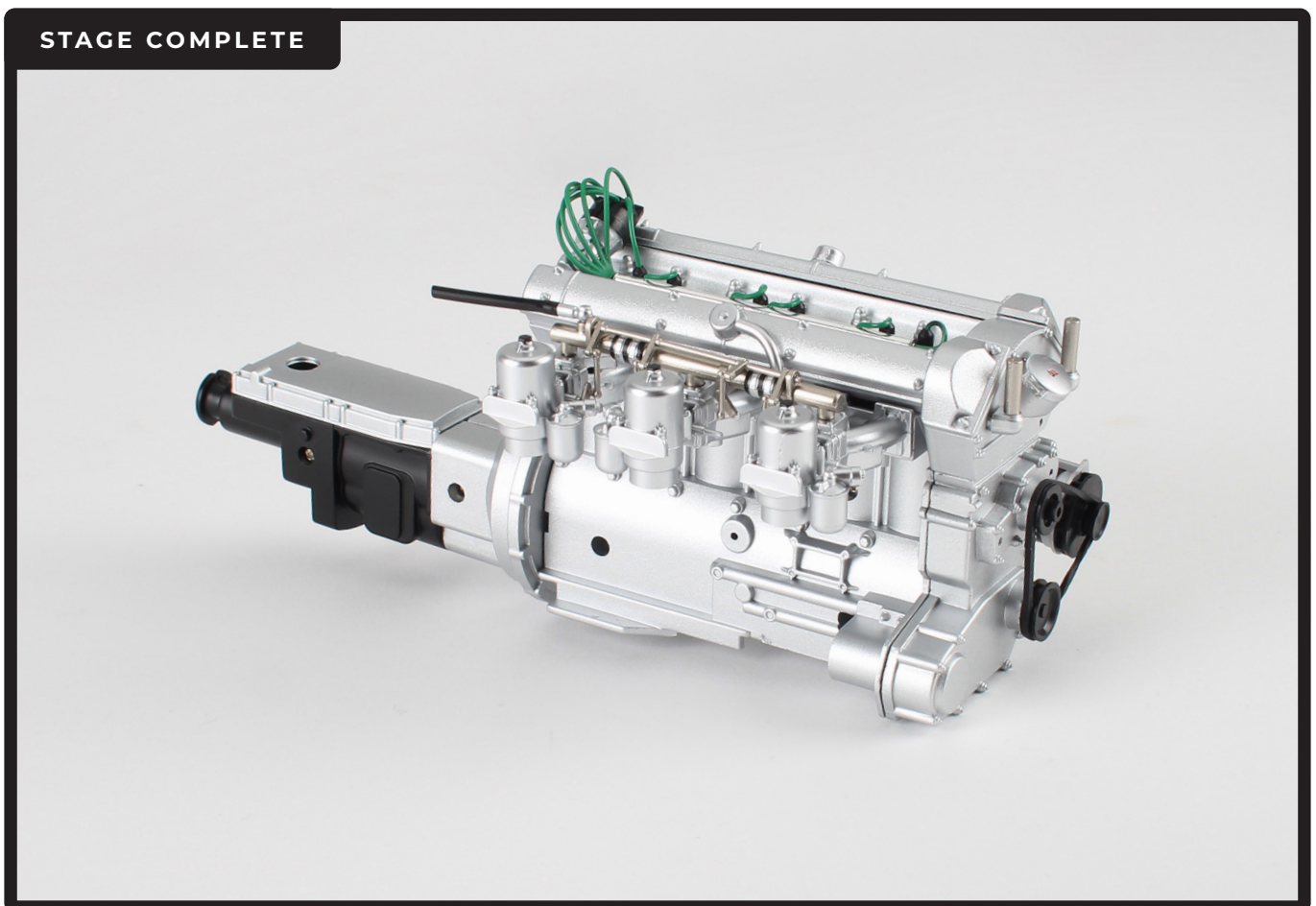

Stage 017: Attaching the Fan, Oil Pump and Pipes

In this stage you'll start attaching the engine's oil pipes and fit the oil pump and fan.



STAGE 017 PARTS LIST

Name
17-A Fan
17-B Oil pump
17-C Front oil pipe
17-D Left oil pipe
17-E Right oil pipe
PS20 screws x3



17-A



17-B



17-C



17-D



17-E



PS20 x3

Stage 017: Attaching the Fan, Oil Pump and Pipes

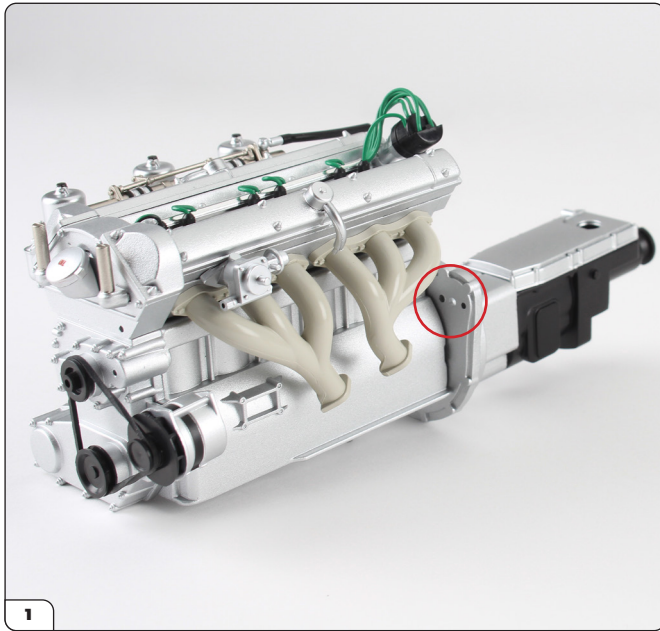

Take the engine assembly and locate the holes for mounting the oil pump.

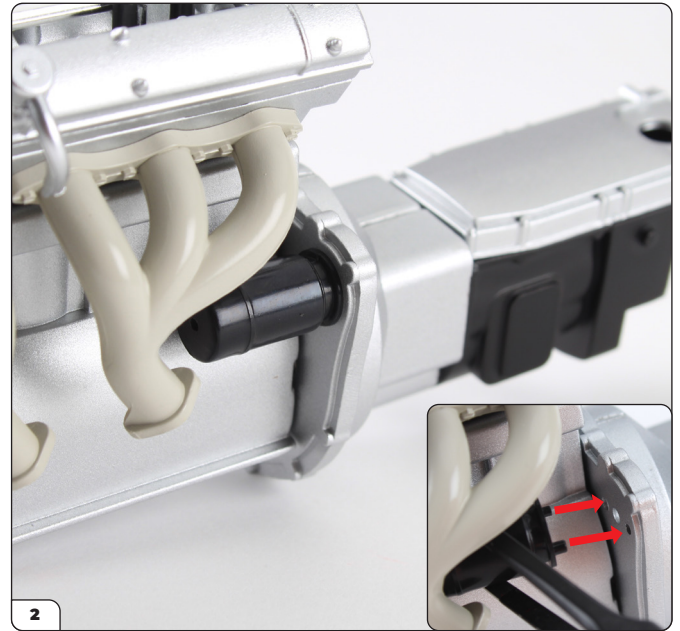

Push pins on the oil pump (17-B) into the two smaller holes (inset).

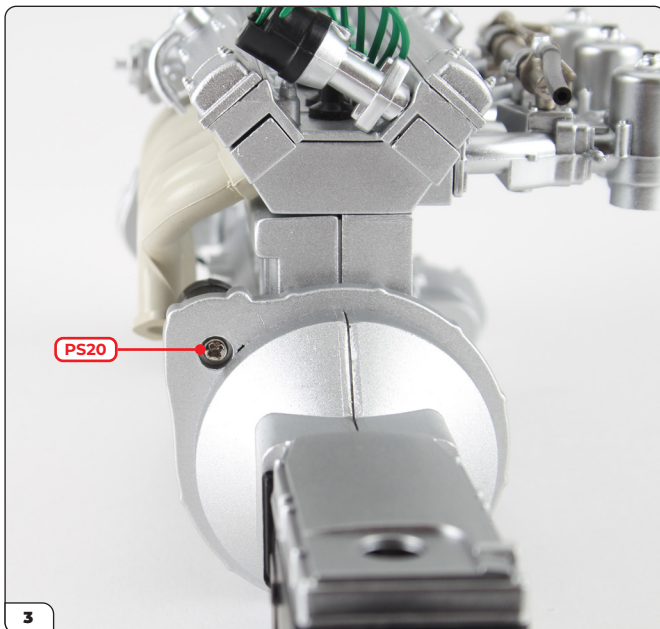

Secure from the other side using a PS20 screw.

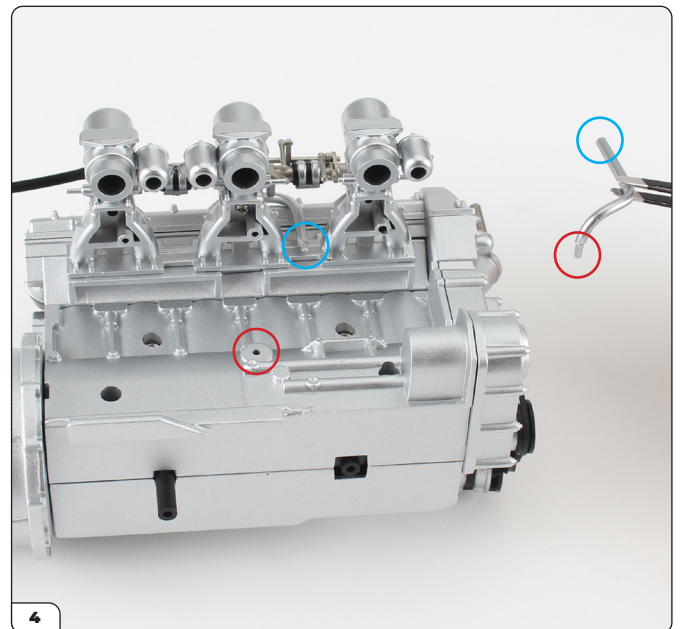

Place the engine on its side and locate the hole and pin for fitting the right oil pipe (17-E).

Stage 017: Attaching the Fan, Oil Pump and Pipes

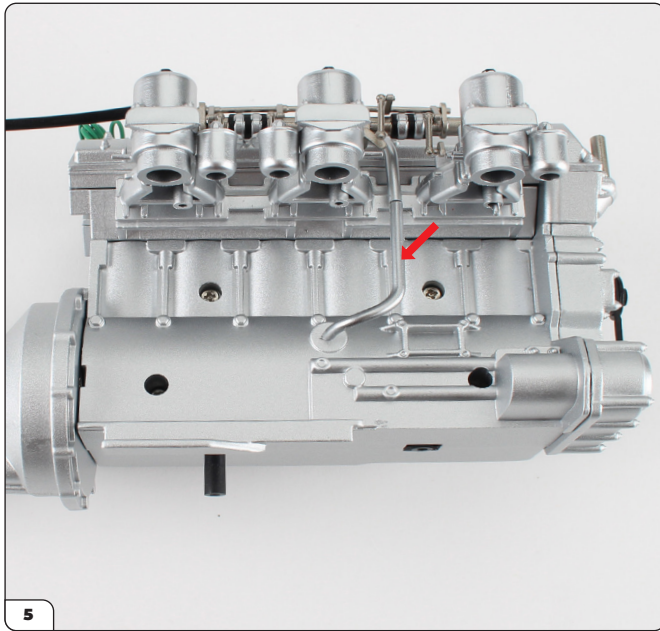

Fit the pipe in place.

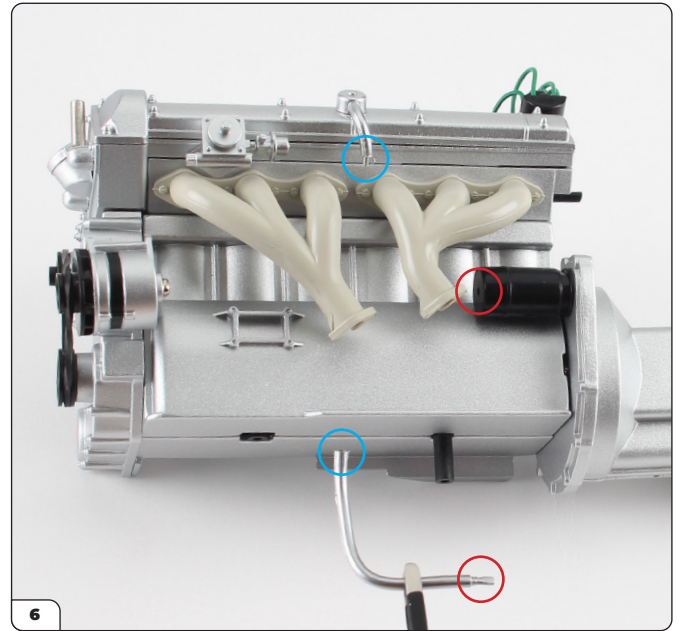

Turn the engine over and locate the hole and pin for fitting the left oil pipe (17-D).

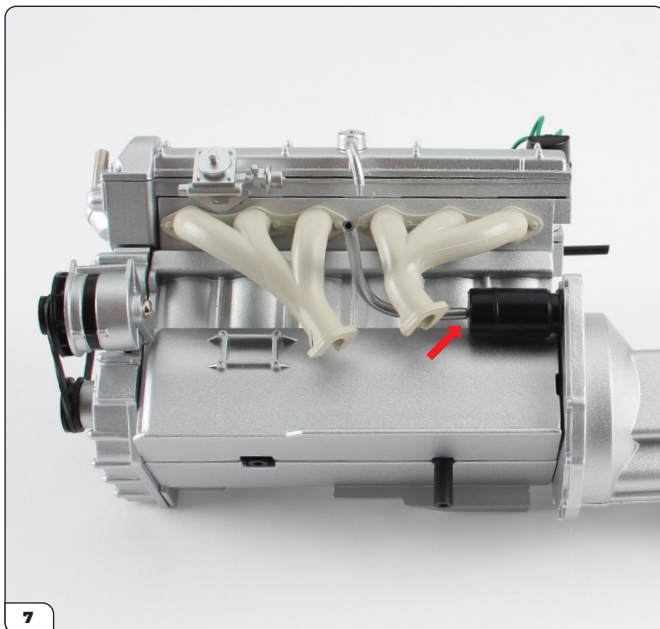

Fit the pipe's pin into the oil pump first.

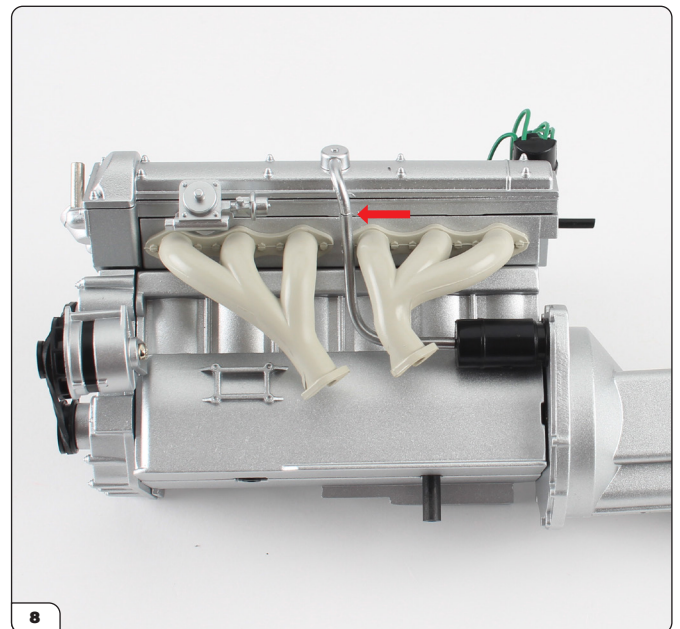

Turn the pipe and fit the other end onto the pin.

Stage 017: Attaching the Fan, Oil Pump and Pipes

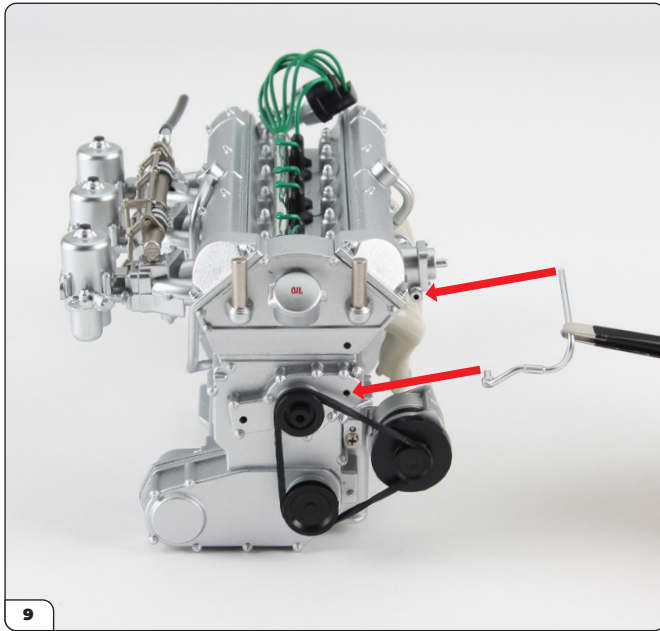

Place the engine with the front facing you and align the front oil pipe (17-C).

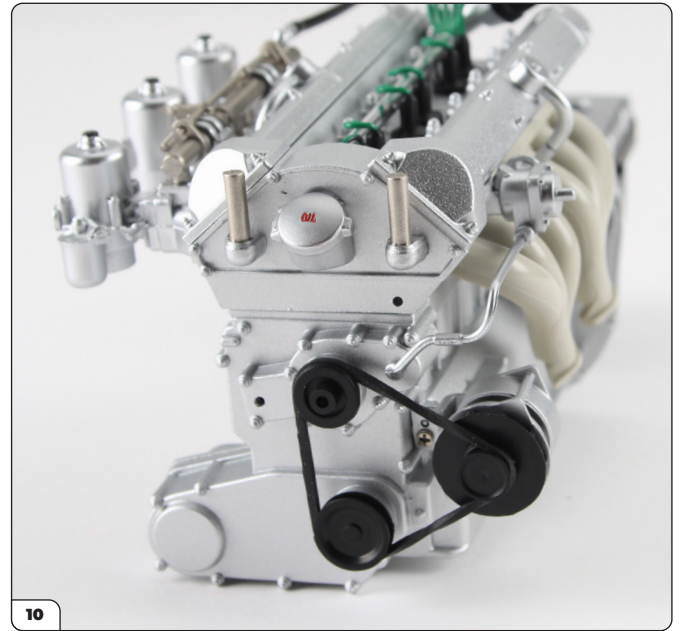

Fit the pipe in place as shown.

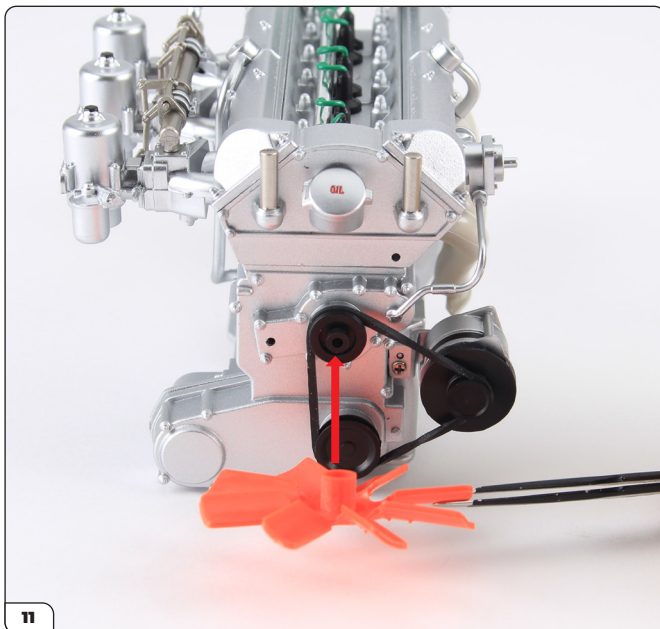

Press the fan (17-A) onto the small pulley.

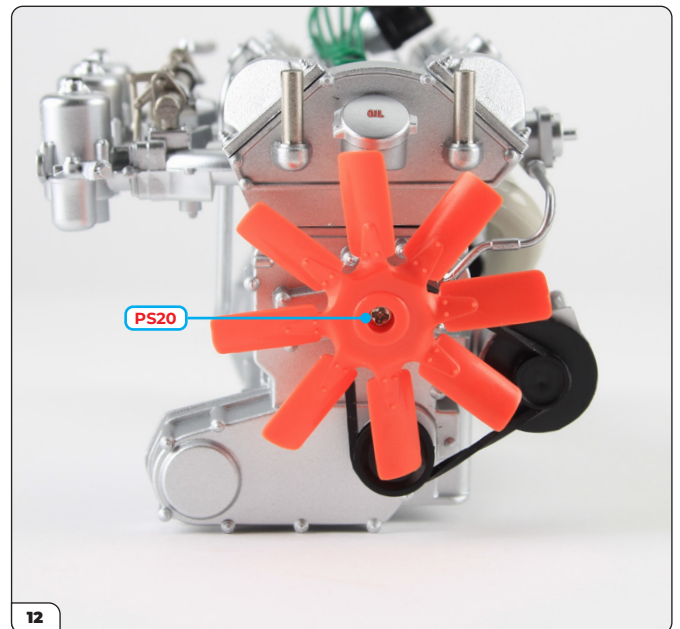

Secure using a PS20 screw.

Stage 017: Attaching the Fan, Oil Pump and Pipes

STAGE COMPLETE

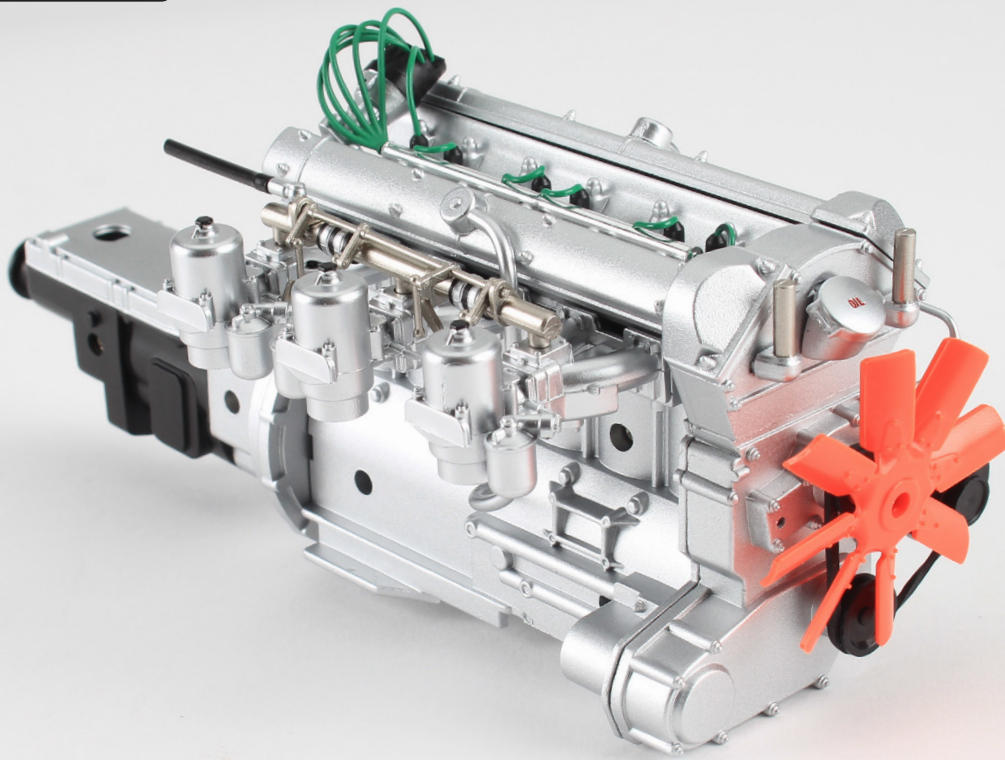

Stage 018: Attaching the Oil Pan

You'll now fit the first part of the oil distribution pipes and attach the oil pan to the engine bottom.



STAGE 018 PARTS LIST

Name
18-A Oil pan
18-B Oil distribution pipe
PS20 screws x3

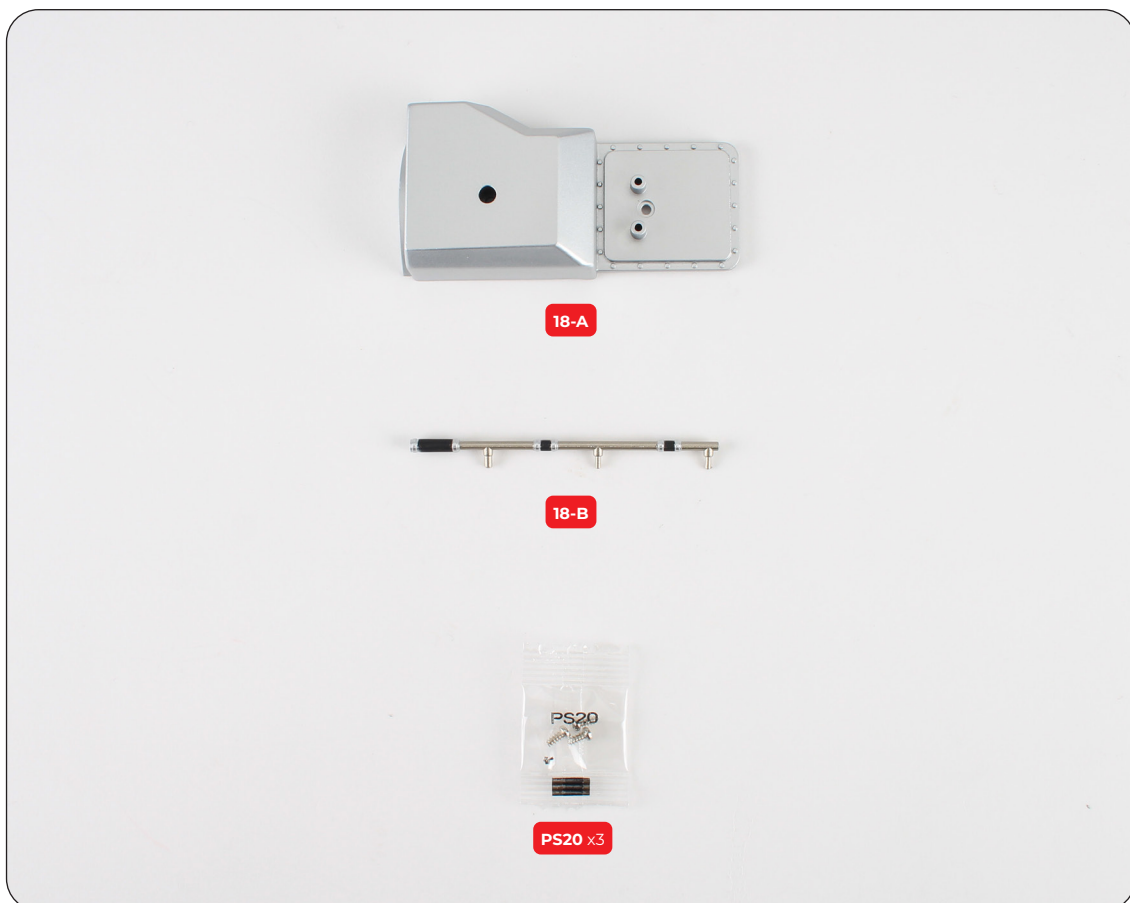

Stage 018: Attaching the Oil Pan

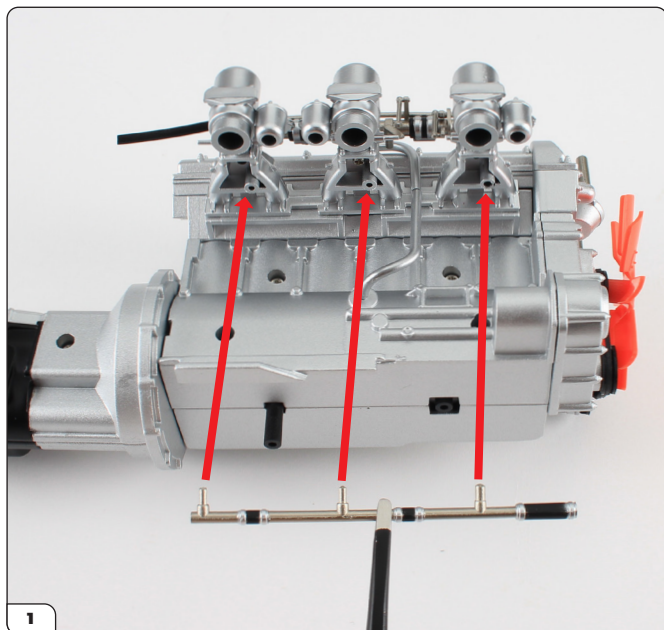

Align the oil distribution pipe (18-B) with the three holes in the carburettor as shown.

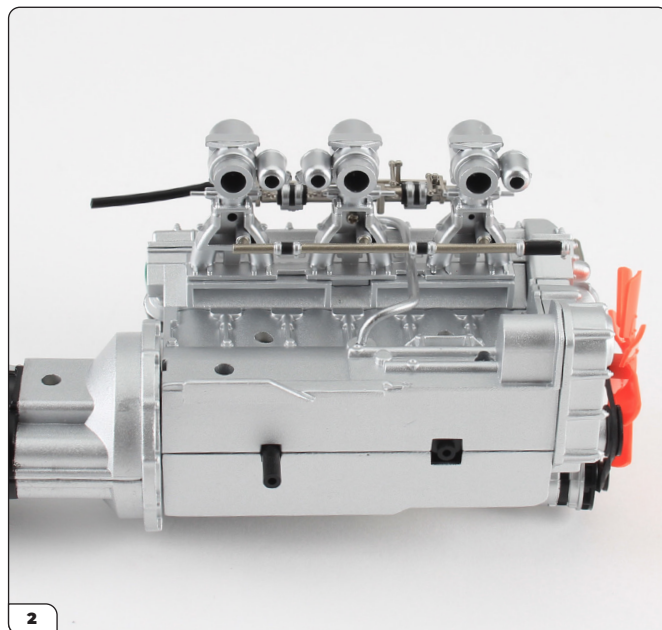

Fit the pipe in place.

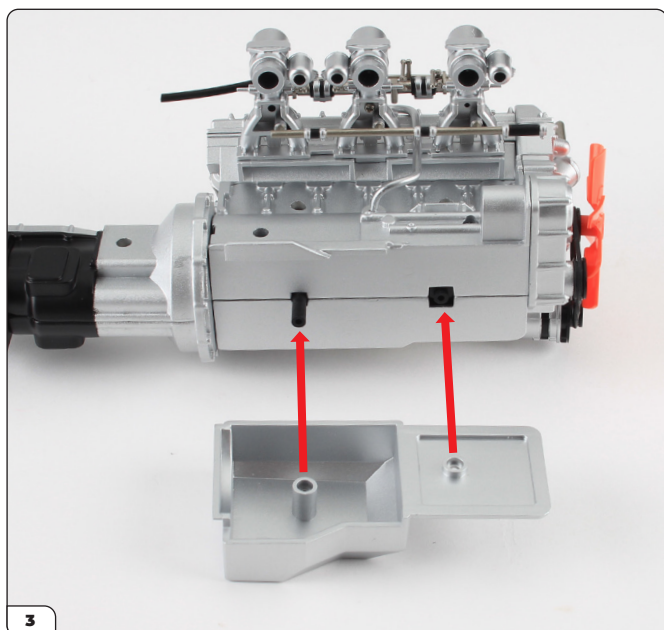

The oil pan (18-A) fits onto the bottom of the engine as shown.

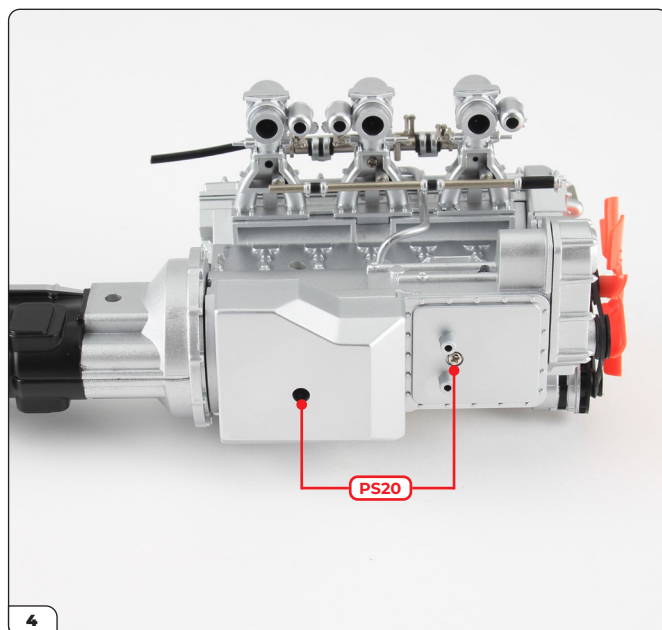

Secure using 2x PS20 screws.

Stage 018: Attaching the Oil Pan

STAGE COMPLETE

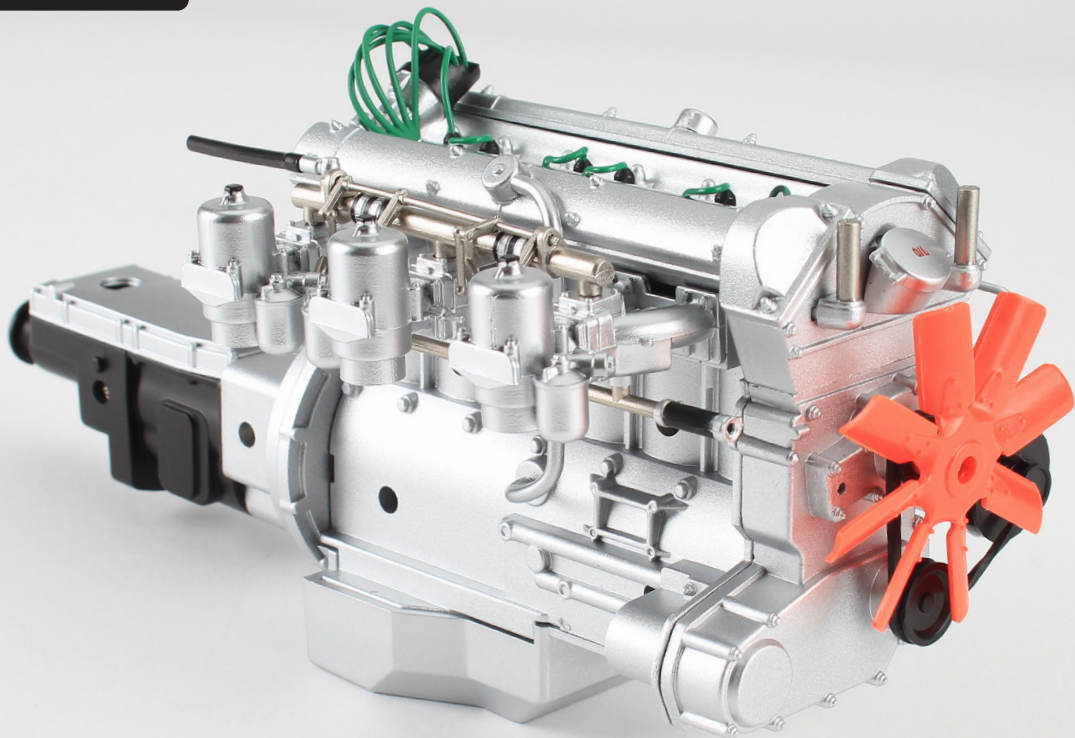

Stage 019: Connecting the Oil Distribution Pipe

In this stage you'll connect the oil distribution pipe to the engine's front. The chassis front will be needed in the next stage.



STAGE 019 PARTS LIST

Name
19-A Chassis front
19-B Oil distribution pipe



Stage 019: Connecting the Oil Distribution Pipe

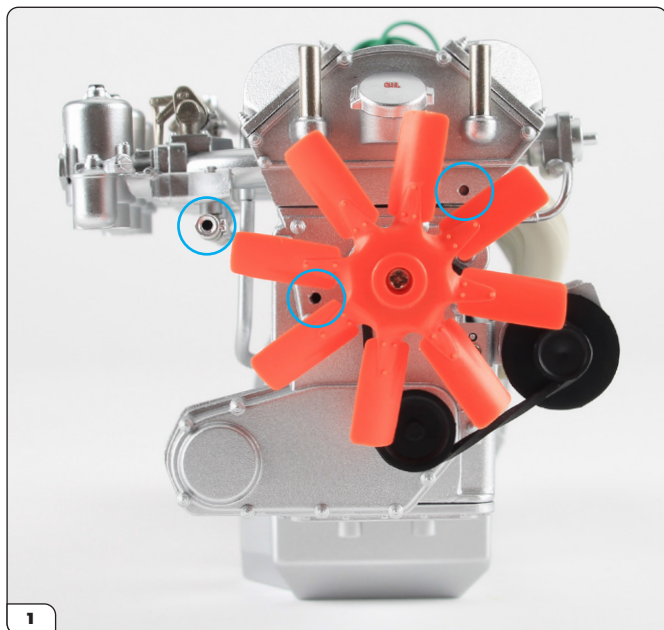

1 Place the engine assembly with the front facing you and locate the three holes for fitting the oil distribution pipe.

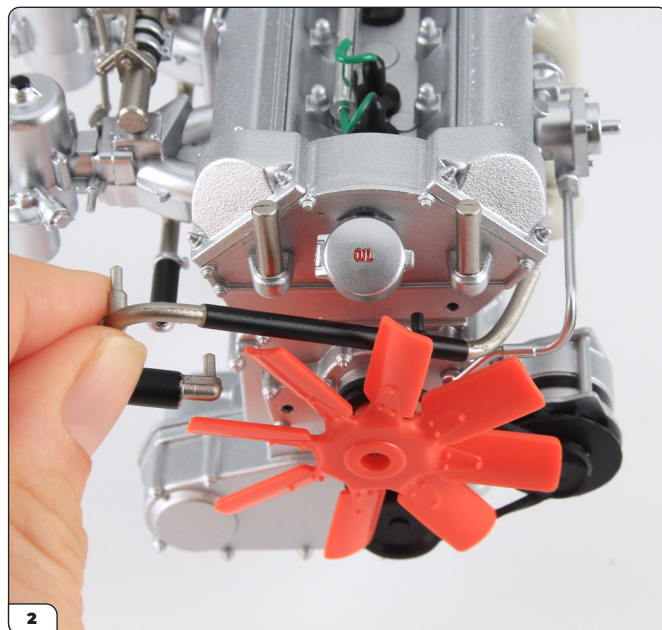

2 Start to fit the distribution pipe (19-B) by passing it behind the fan as shown.

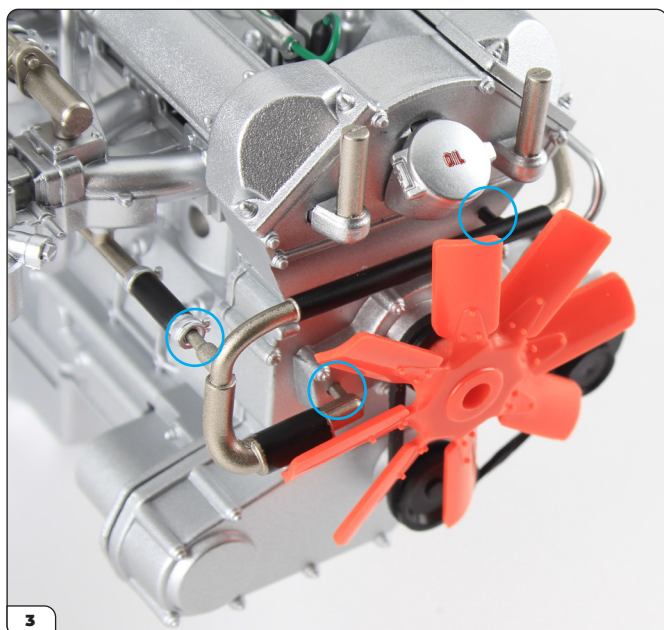

3 Position the pins into the holes one at a time.

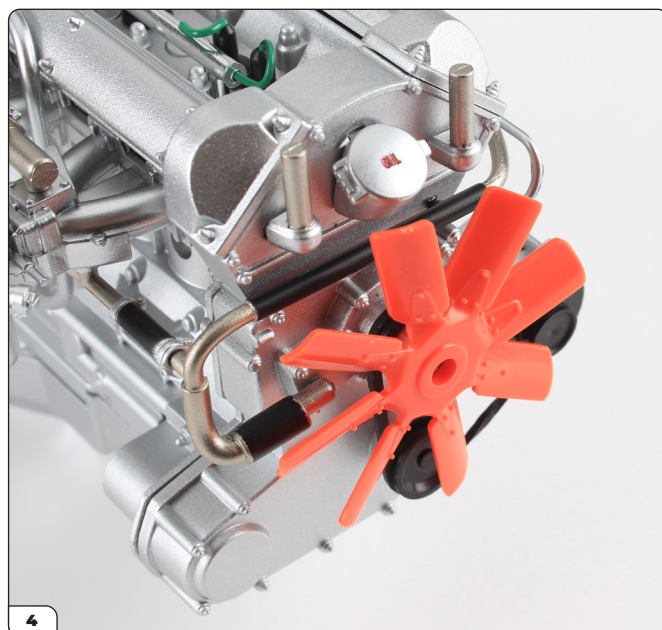

4 Press each pin in firmly.

Stage 019: Connecting the Oil Distribution Pipe

STAGE COMPLETE

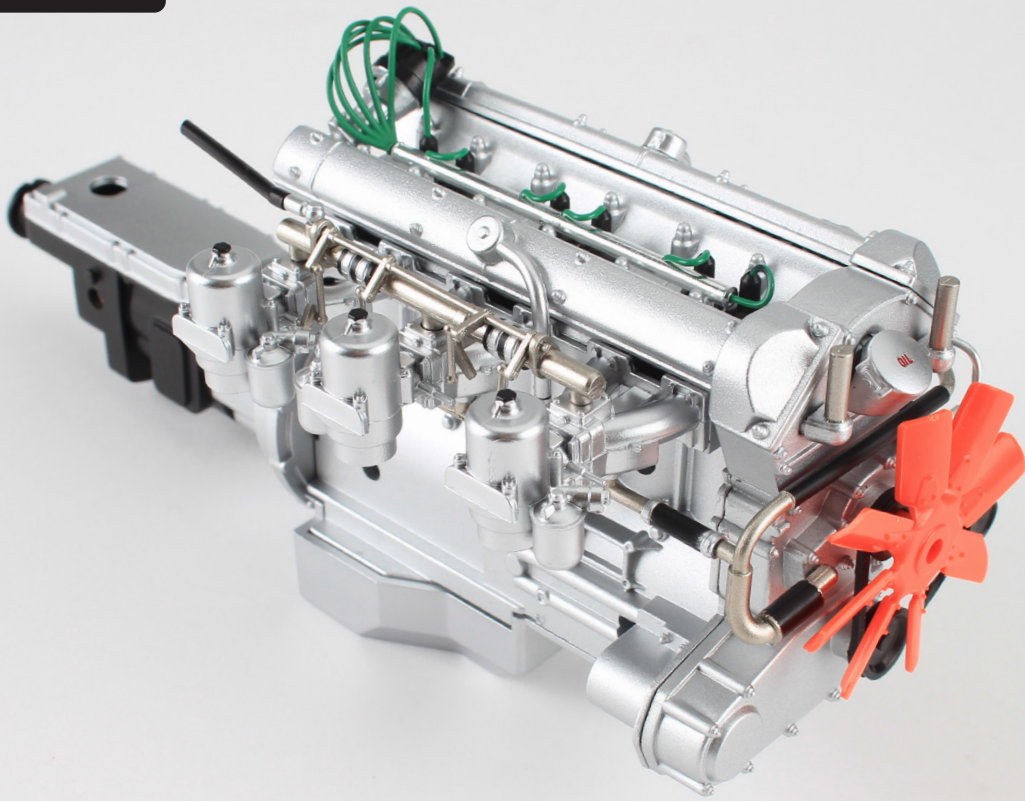

Stage 020: Fixing the Suspension Mounts

In this stage you'll fix the suspension mounts onto the chassis front.



STAGE 020 PARTS LIST

Name
20-A Left suspension mount
20-B Right suspension mount
DS02 screws x7



Stage 020: Fixing the Suspension Mounts

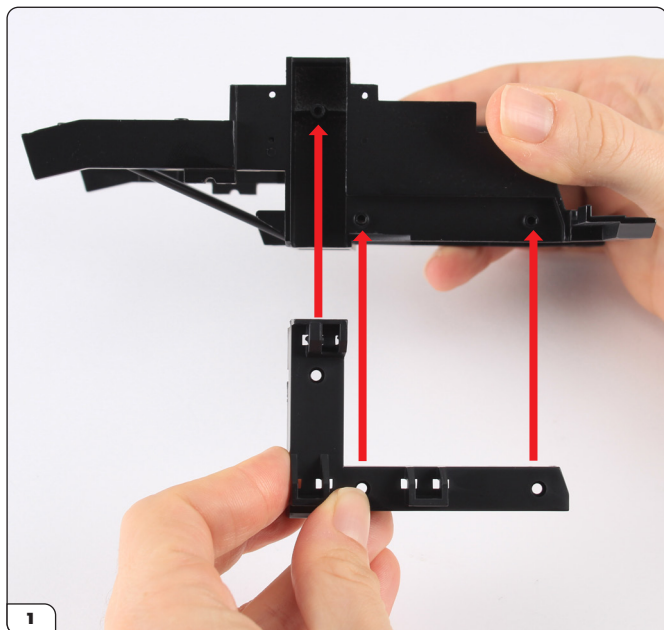

Take the chassis front from stage 19 and the left suspension mount (20-A), aligning them as shown.

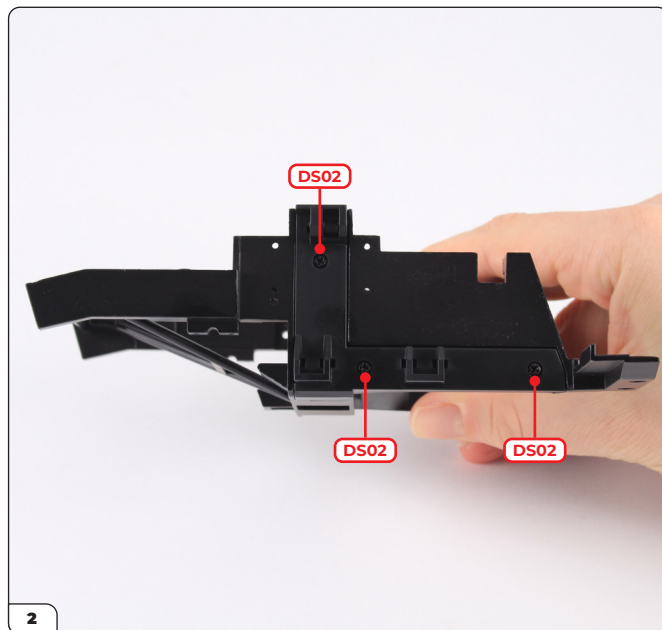

Fit together and secure with 3x DS02 screws.

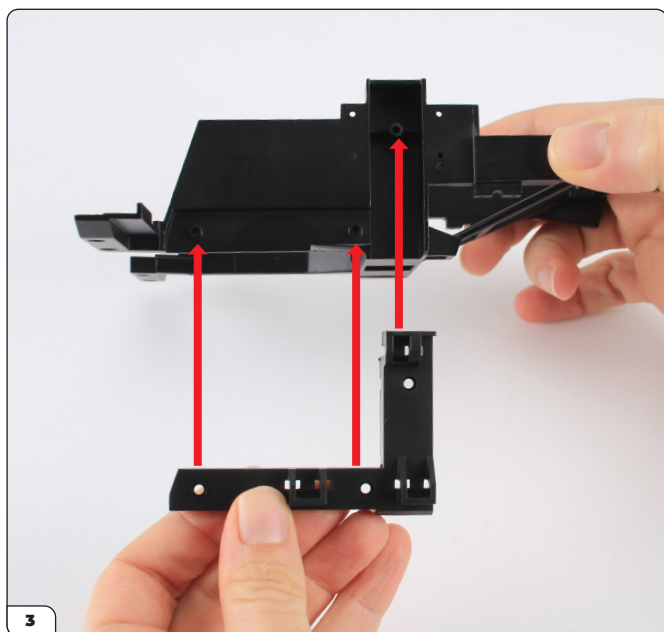

Fit the right suspension mount (20-B) onto the other side.

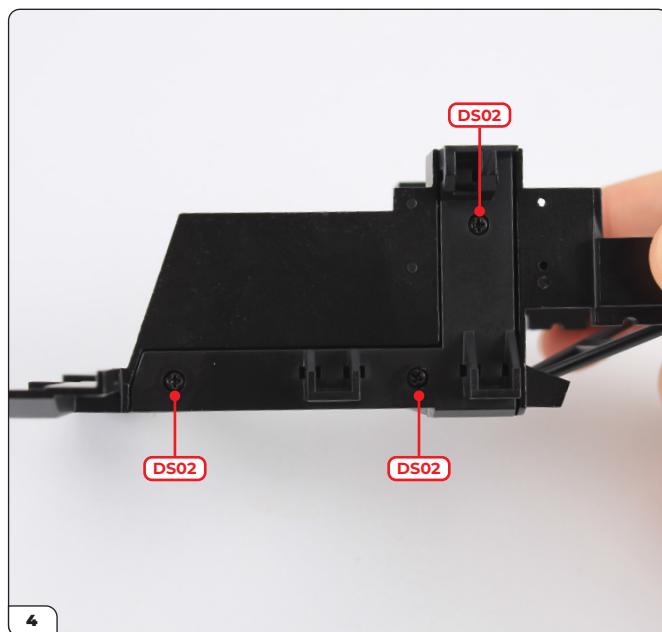

Secure with 3x DS02 screws.

Stage 020: Fixing the Suspension Mounts

STAGE COMPLETE

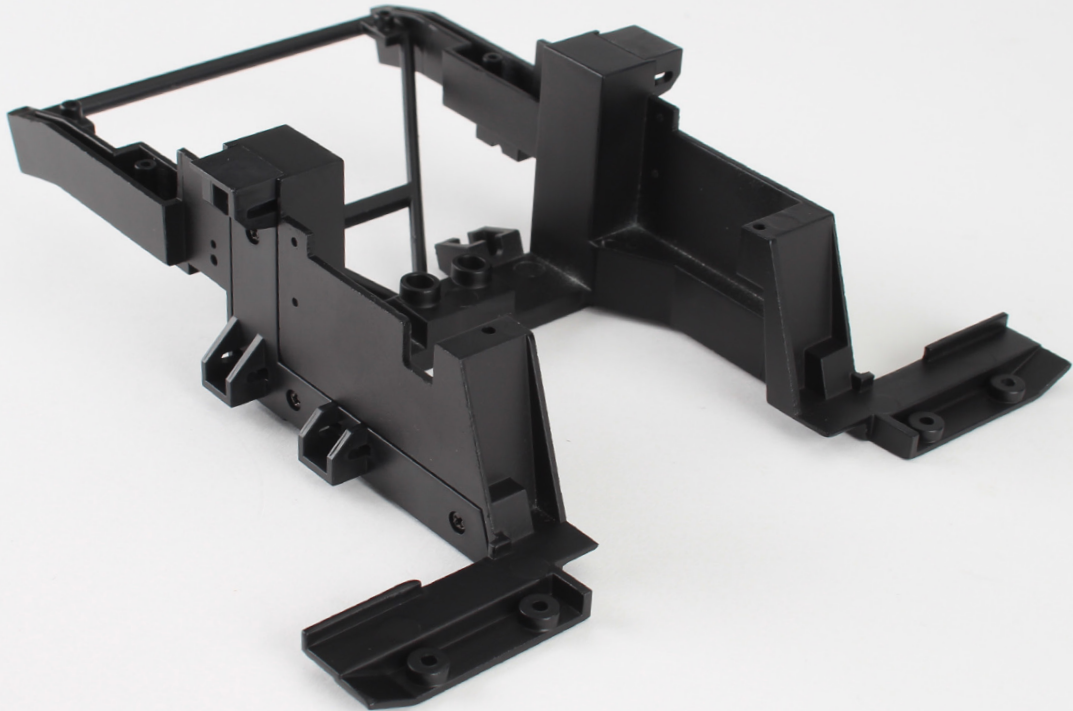

Stage 021: Joining the Front and Middle Chassis

Next you'll join the front and middle chassis parts together.



STAGE 021 PARTS LIST

Name
21-A Chassis middle
DS02 screws x5



Stage 021: Joining the Front and Middle Chassis

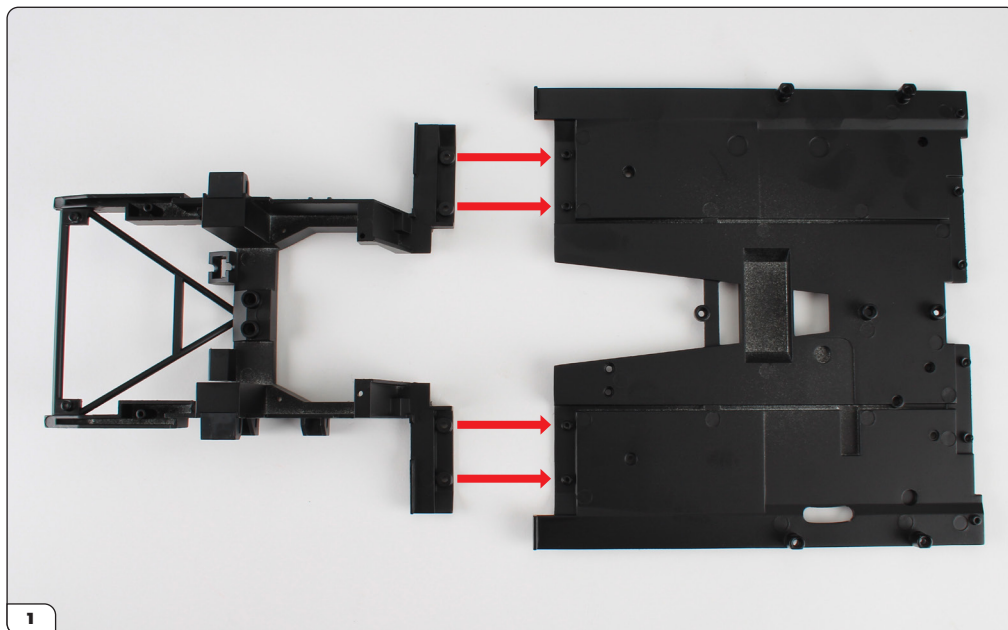

Align the front (stage 20) and middle (21-A) chassis parts as shown.

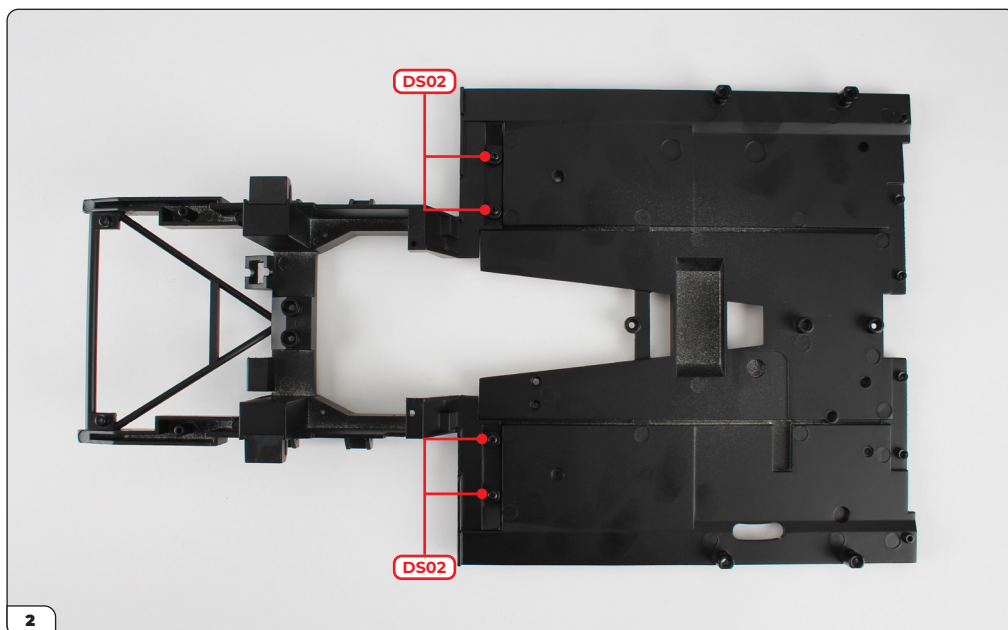

Fit the front onto the middle and secure using 4x DS02 screws.

Stage 021: Joining the Front and Middle Chassis

STAGE COMPLETE

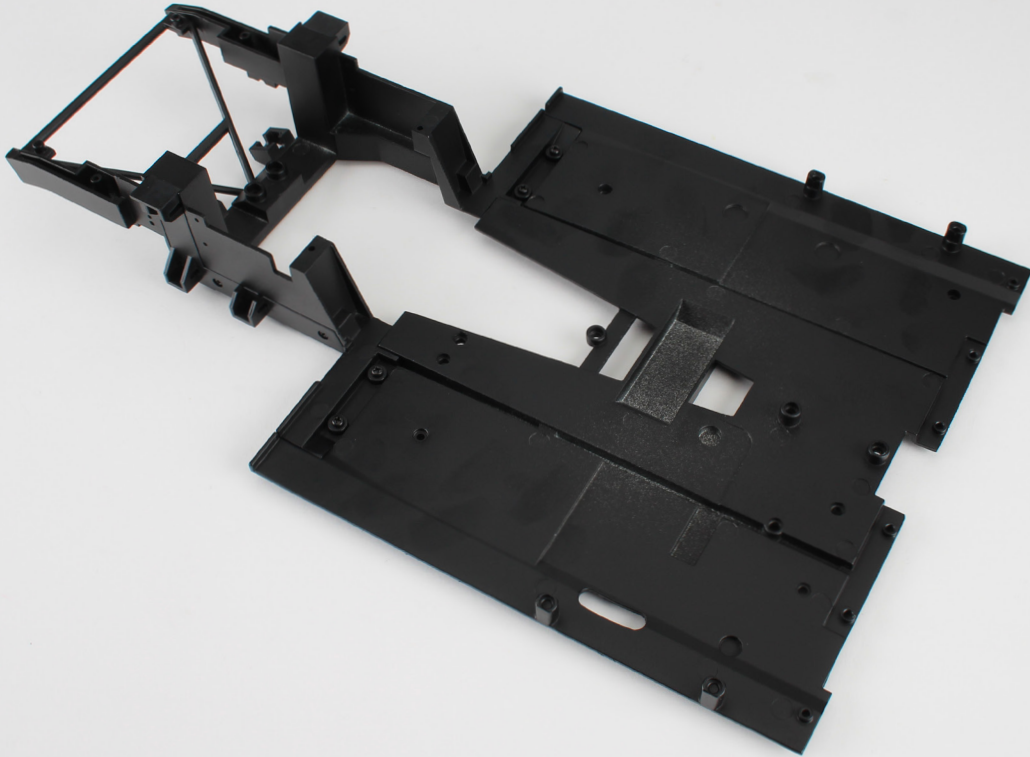

Stage 022: Building the Right Wheel Hub and Fitting the Upper Right Control Arm

In this stage you'll build the right wheel hub by fitting the brake disc and caliper. You'll then fit the upper control arm to the chassis.



STAGE 022 PARTS LIST

Name
22-A Right wheel hub
22-B Upper right control arm
22-C Brake disc
22-D Caliper
22-E Upper control arm bracket x2
DS21 screws x3
DS27 screws x5

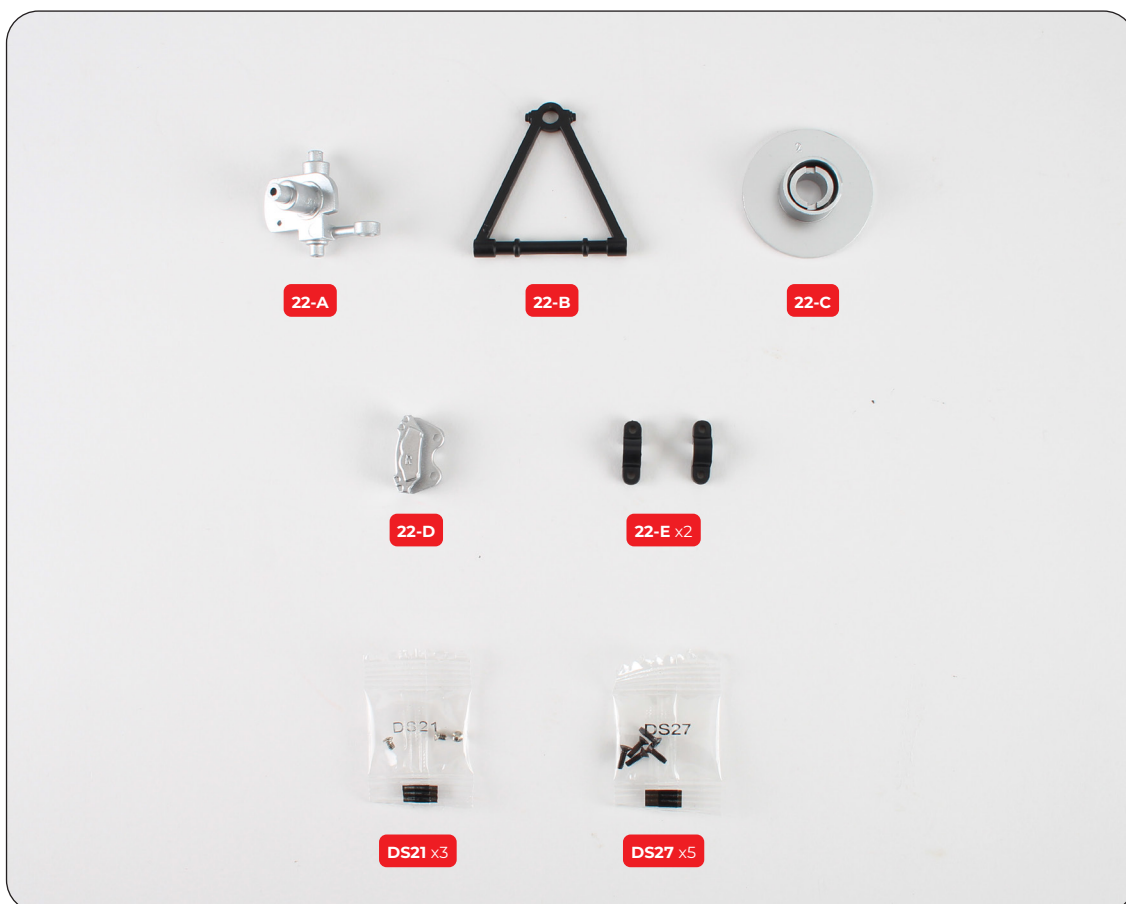

Stage 022: Building the Right Wheel Hub and Fitting the Upper Right Control Arm

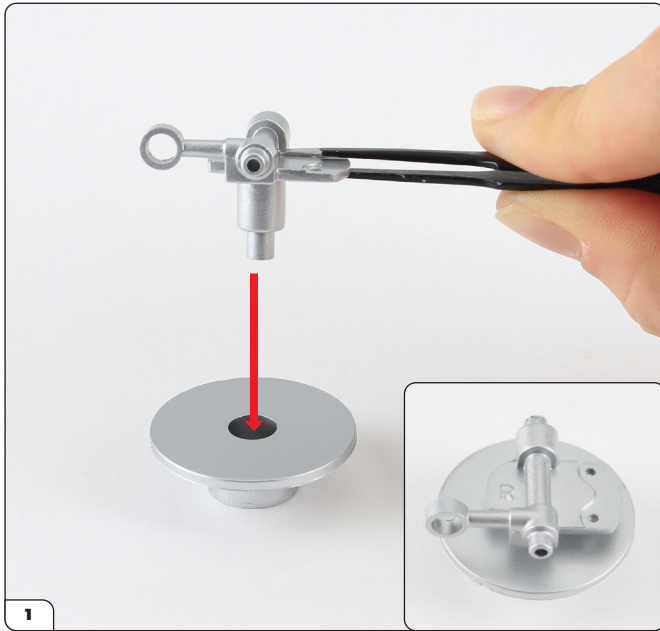

1 Take the brake disc (22-C) and the right wheel hub (22-A) and fit them together as shown.

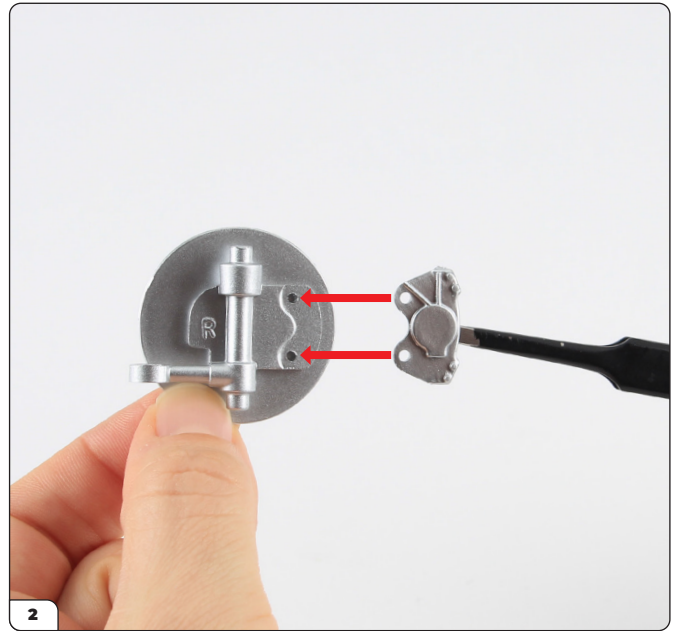

2 Fit the caliper (22-D) onto the assembly.

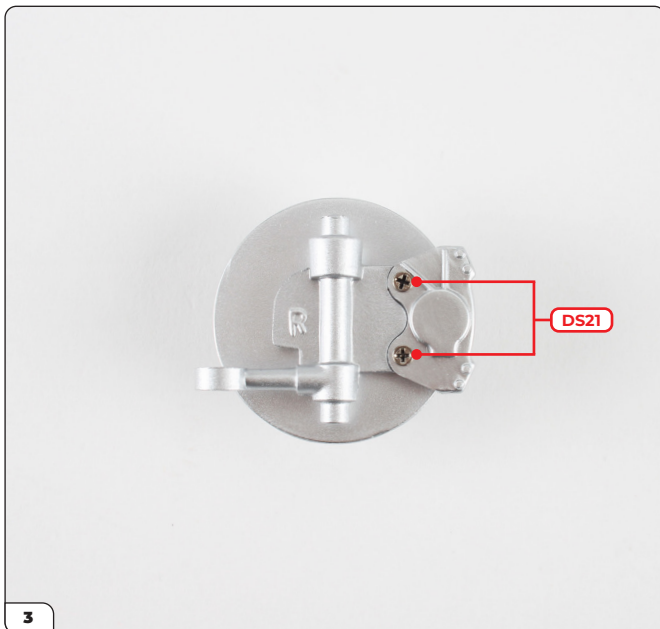

3 Secure with 2x DS21 screws. Do not overtighten the screws.



4 Prepare the brackets (22-E, inset) and 4x DS27 screws. Align the upper right control arm (22-B) with the right side of the front chassis (stage 21). Note the four screw holes for fixing the brackets.

Stage 022: Building the Right Wheel Hub and Fitting the Upper Right Control Arm

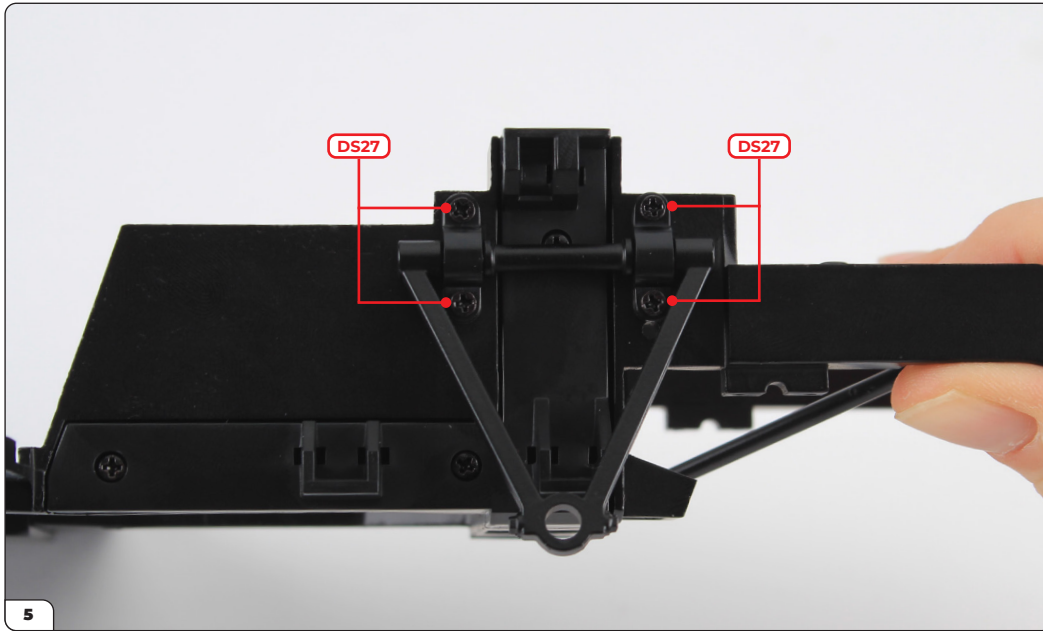

Position the upper control arm between the holes and secure it using the brackets and DS27 screws as shown.

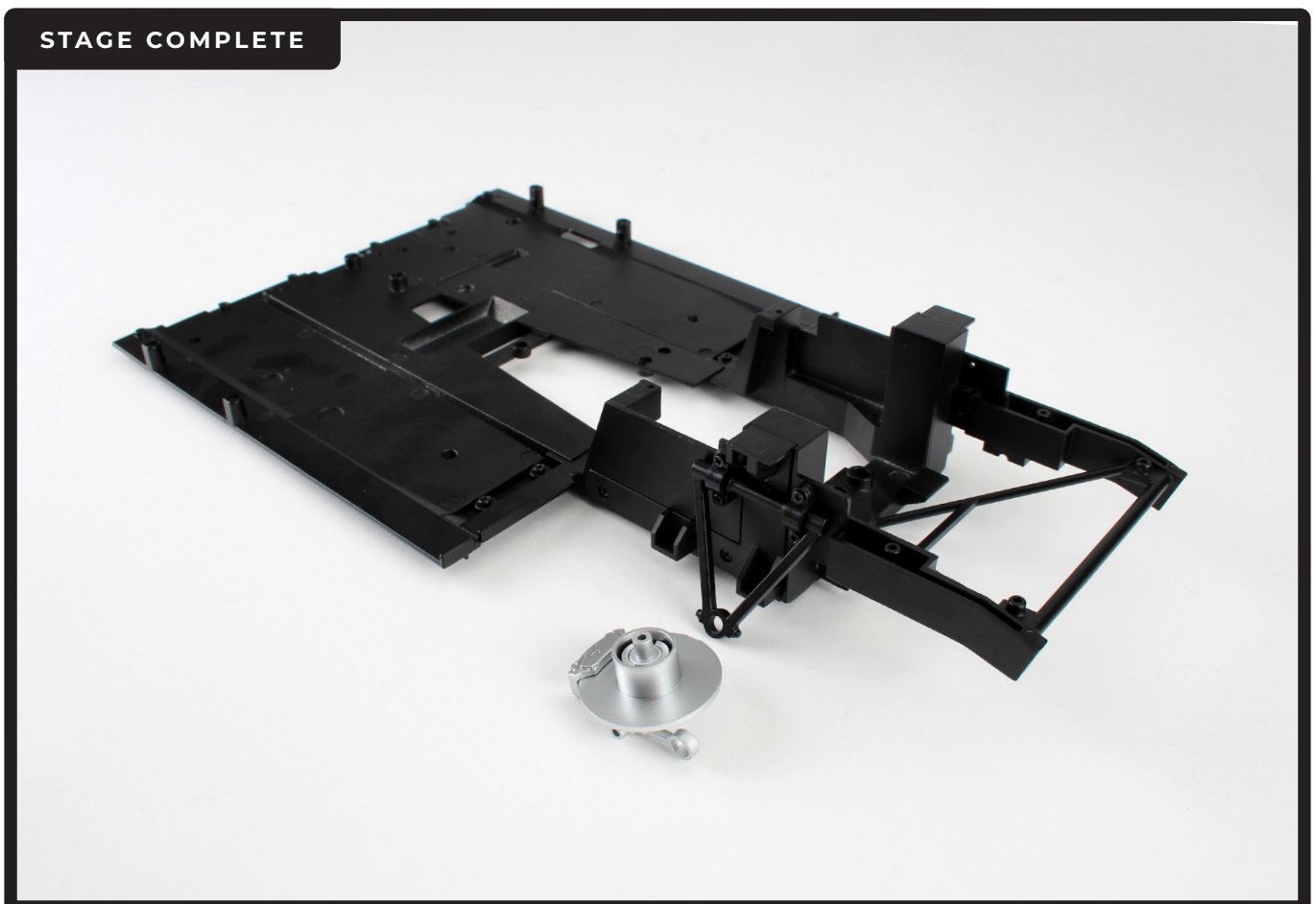

Stage 023: Assembling the Front Right Suspension

In this stage you'll assemble the front right suspension by fixing the lower control arm, fitting the shock absorber and attaching the wheel hub.



STAGE 023 PARTS LIST

Name
23-A Lower right control arm
23-B Shock absorber cylinder
23-C Shock absorber spring
23-D Shock absorber rod
23-E Anti-roll bar connection
23-F Pin x4
DS24 screws x3
PS31 screws x2

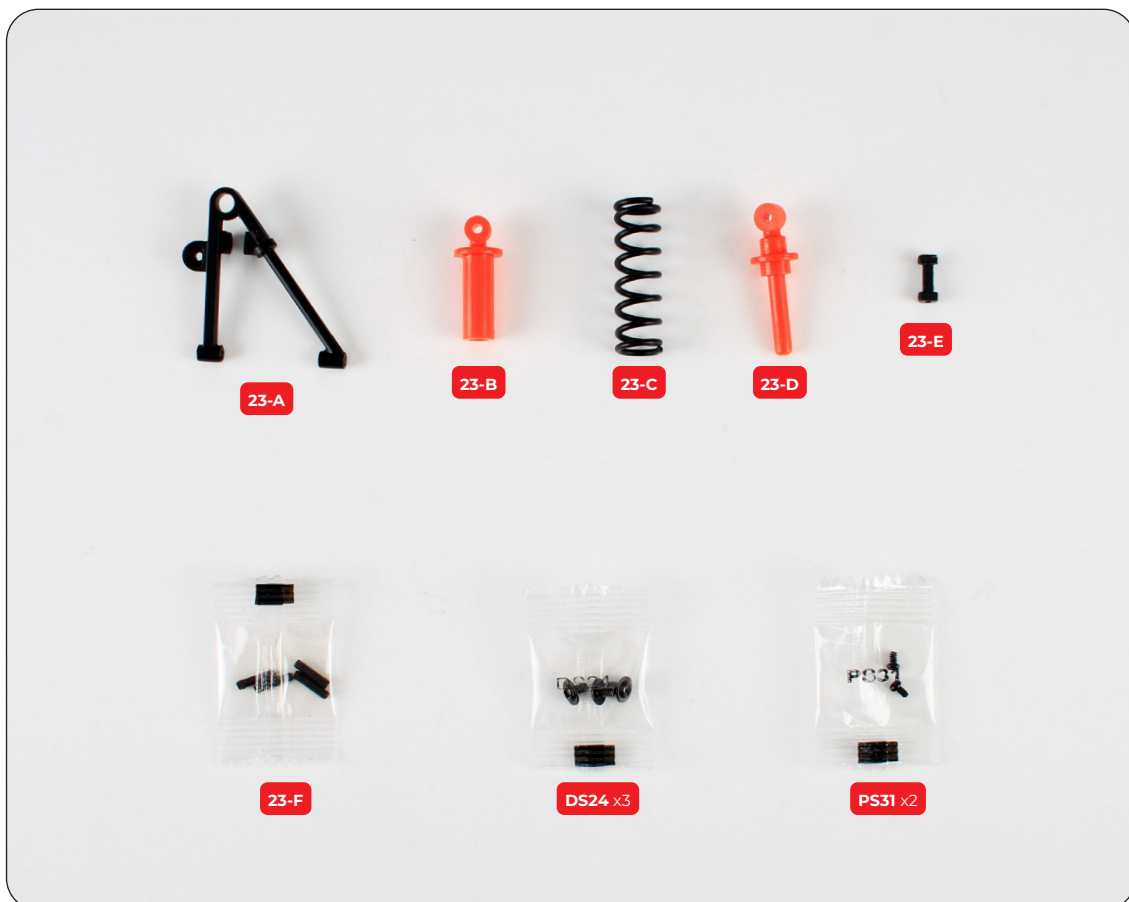

Stage 023: Assembling the Front Right Suspension

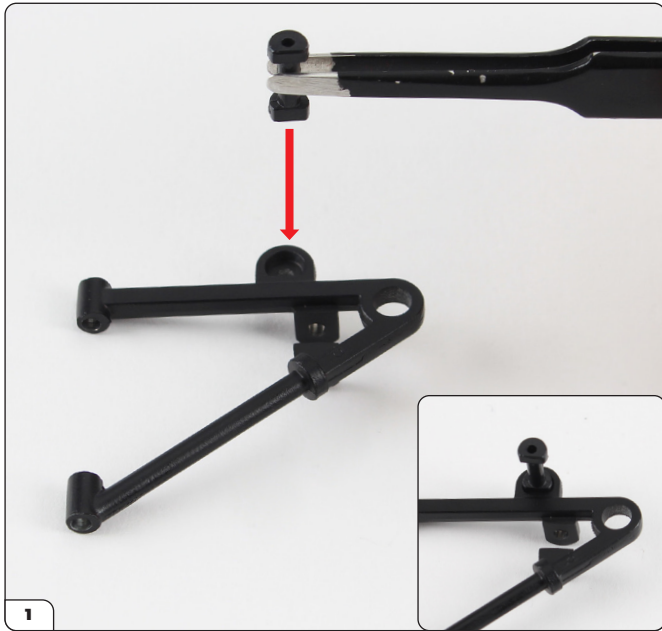

Take the lower right control arm (23-A) and the anti roll bar connection (23-E). Fit them together as shown using the D-shape to ensure the correct orientation. The connection can be fitted in either way.

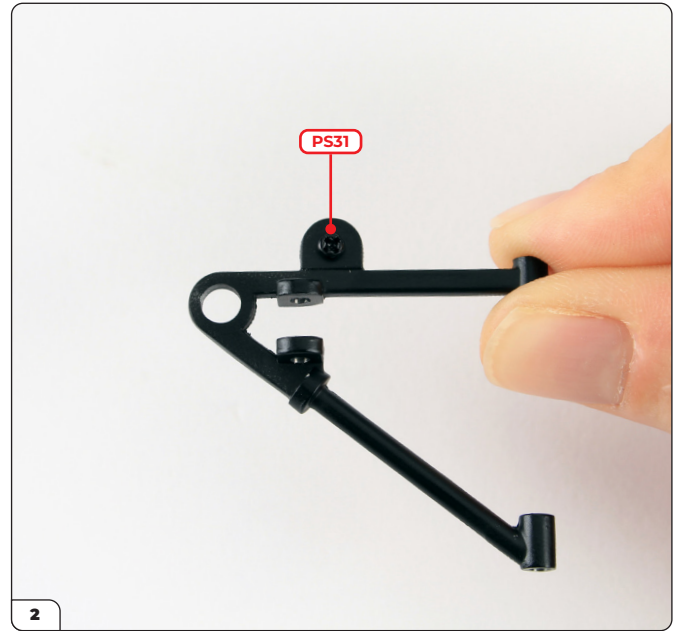

Secure from the other side using a PS31 screw.

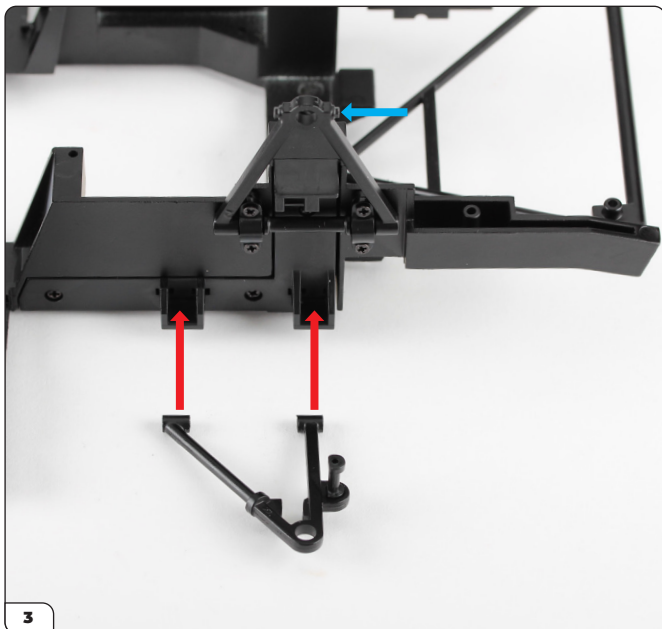

Align the lower control arm with the front chassis' right side. Lift the upper control arm out of the way (blue arrow).

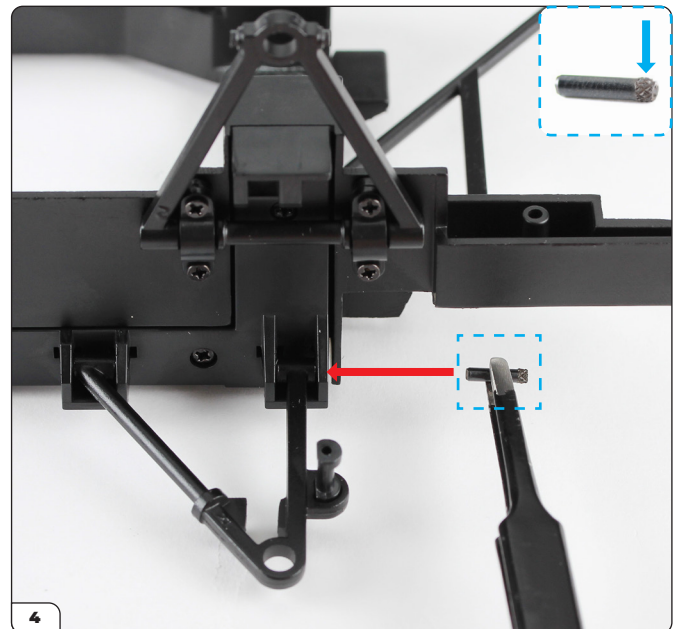

Fit the control arm in place then fit a pin (23-F) through the mount and arm. One end of the pin is splined (inset). Fit the pin's smooth end first.

Stage 023: Assembling the Front Right Suspension

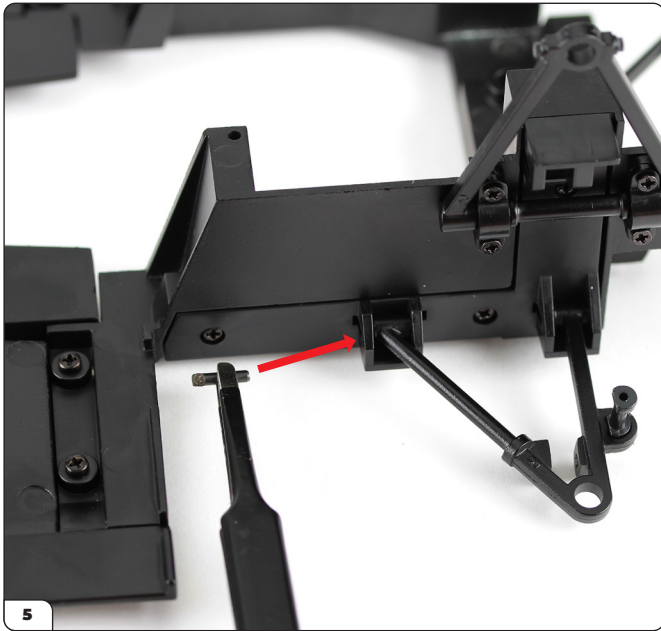

5 Fit a pin through the other mount in the same way.

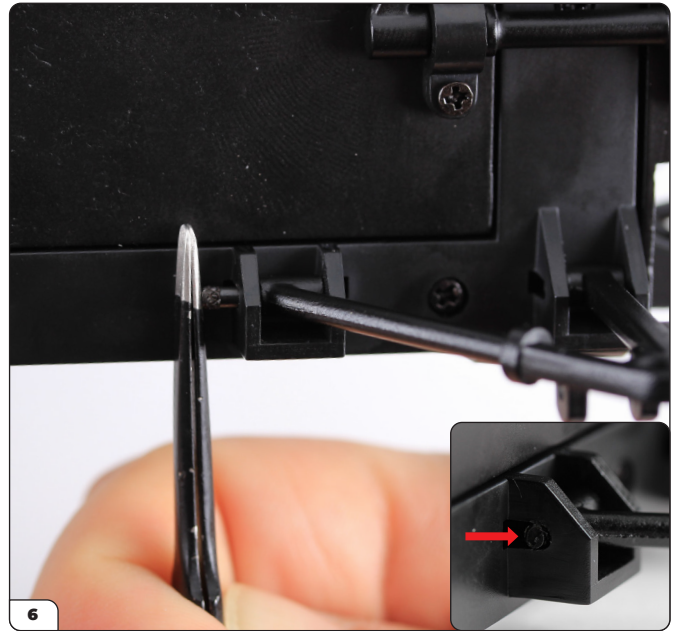

6 Apply pressure to the splined ends of the pins until they fit flush into the mounts (inset). You can also use pliers for this process.

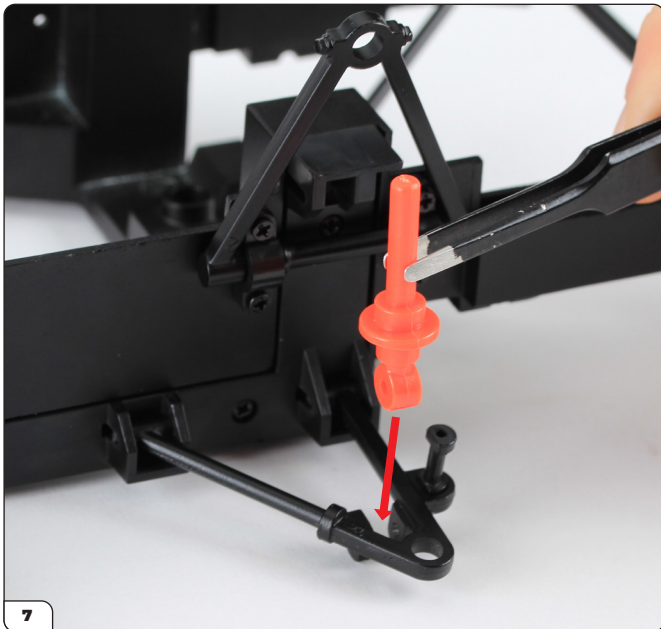

7 Push the circular end of the shock absorber rod (23-D) into the lower control arm.

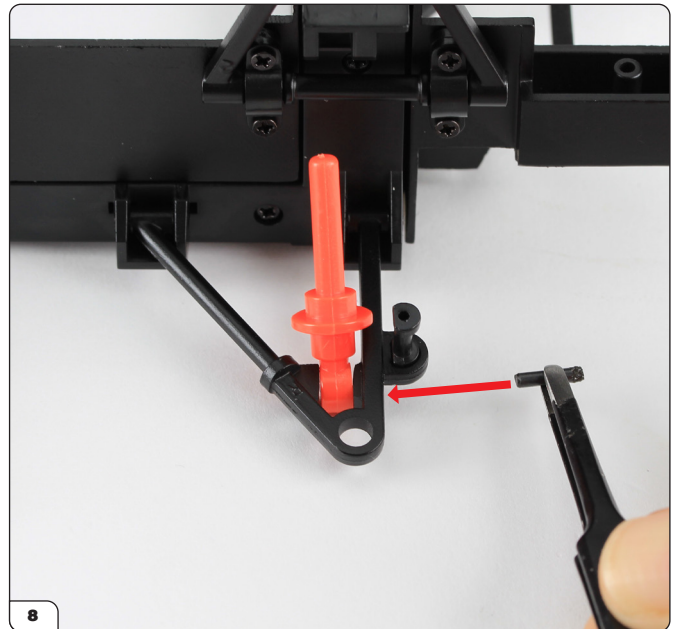

8 Fit a pin through the arm and rod in the same way as before.

Stage 023: Assembling the Front Right Suspension



Place the spring (23-C) over the rod.

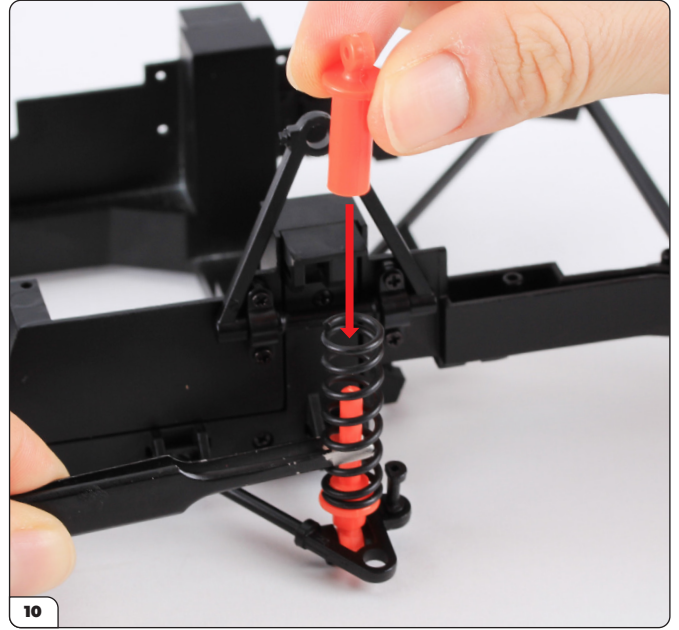

Push the shock absorber cylinder (23-B) through the spring and onto the rod.

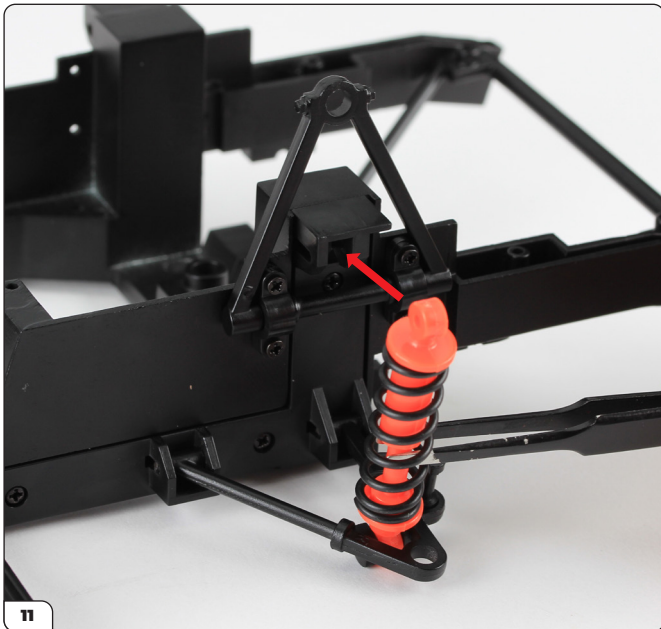

Fit the circular end of the cylinder into the suspension mount.

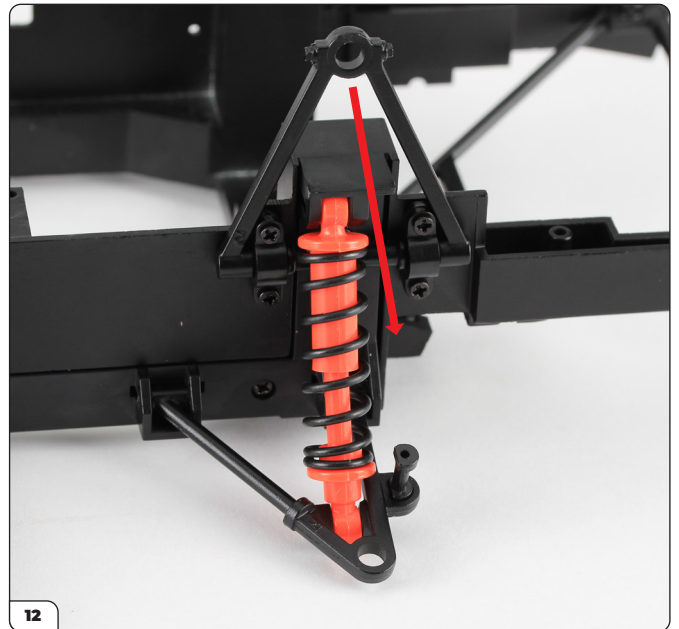

Lower the upper control arm out of the way.

Stage 023: Assembling the Front Right Suspension

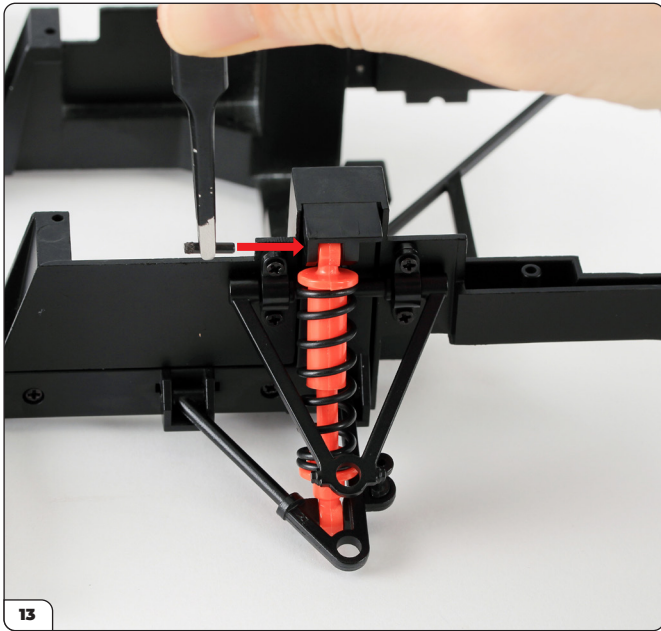

Fit a pin through the mount and cylinder.

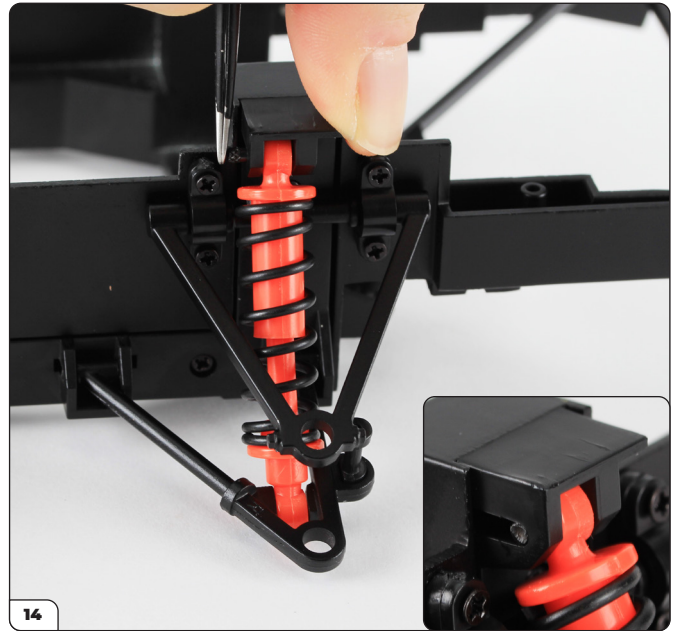

Press the pin fully into the mount in the same way as before.

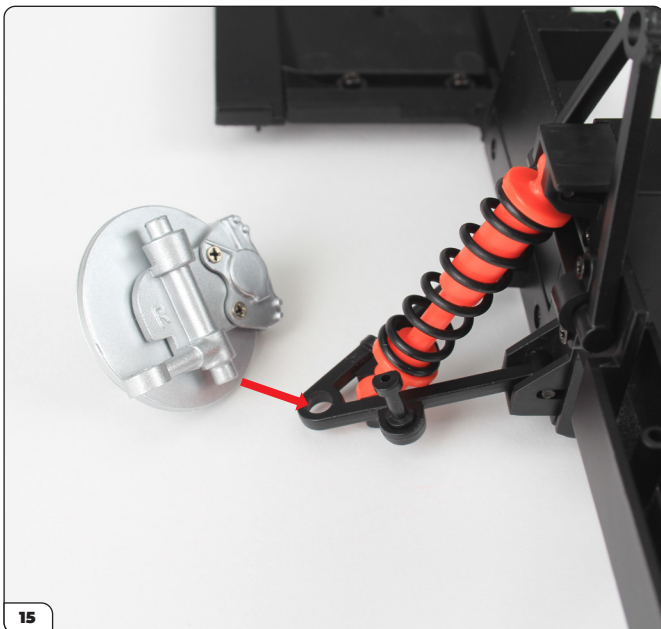

The right wheel hub (from stage 022) fits onto the lower control arm in the orientation shown.



Fit the wheel hub onto the lower control arm.

Stage 023: Assembling the Front Right Suspension

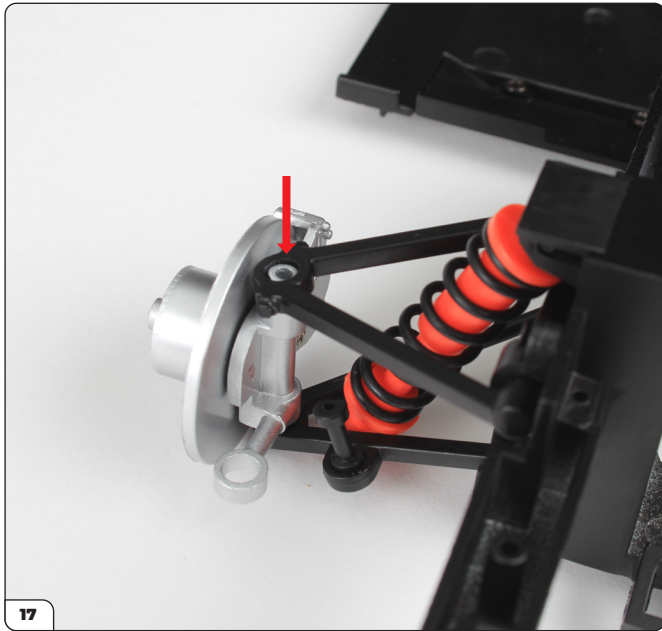

Fit the upper control arm onto the wheel hub.



Lift up the assembly and secure the lower control arm from underneath with a DS24 screw.

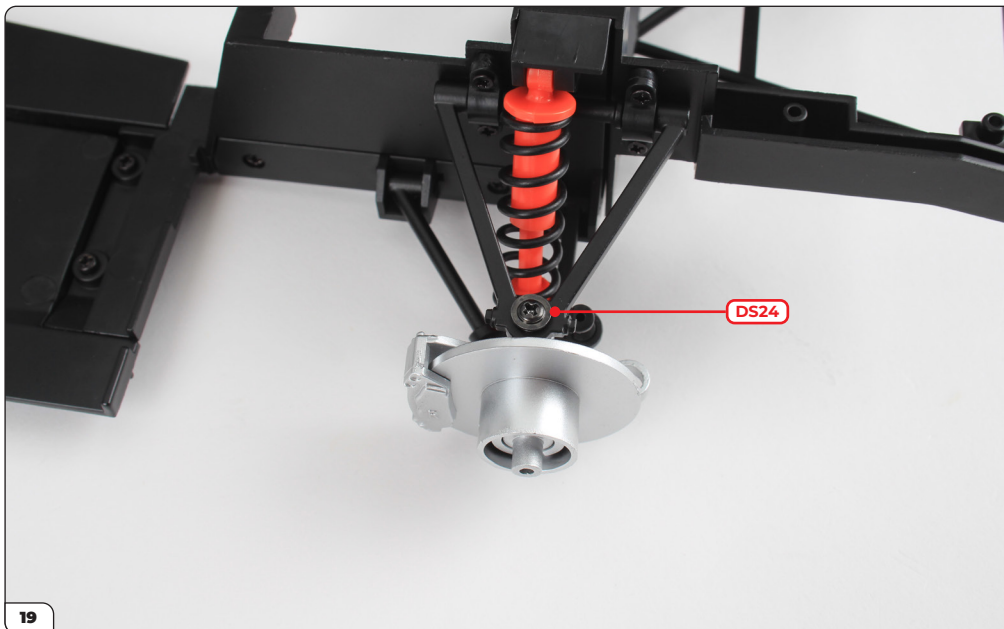

Fix the upper control arm with another DS24 screw.

Stage 023: Assembling the Front Right Suspension

STAGE COMPLETE

