

1955

MERCEDES-BENZ

300 SL

GULLWING



Pack 09

BUILD INSTRUCTIONS

STAGE 57: THE LEFT DOOR

STAGE 58: THE LEFT DOOR HEADLINER
AND WINDOW

STAGE 59: THE LEFT DOOR INNER PANEL

STAGE 60: THE RIGHT DOOR

STAGE 61: THE RIGHT DOOR HEADLINER
AND WINDOW

STAGE 62: THE RIGHT DOOR INNER PANEL

STAGE 63: THE DOOR HINGES

"MERCEDES-BENZ" and  are the intellectual property of Mercedes-Benz Group AG.
They are used by Agora Models under license.

AGORA
MODELS

Advice from the experts

Spare screws are included with each part. Occasionally, you may be instructed to keep spare or unused screws for a later stage. Keep these spares in a safe place and label them correctly.

Please make sure you don't mix up the screws. They look quite similar, but the threads do vary slightly. Using the wrong screws may damage the parts.

When securing parts together using multiple screws, fit each screw loosely to ensure all the parts are correctly aligned before gently tightening them firmly, but not overtight, in the order in which you placed them.

The screwdriver can be magnetized by stroking it with a magnet (fridge magnet, etc.) enabling it to hold the screws and make assembly easier.

If a screw is tight going into a metal part, do not force it as you may shear the head off. Remove it and put a tiny smear of Vaseline, soap or light oil on the thread. That will lubricate it and make it easier to drive home.

During the course of this build, you will receive many pieces that you will assemble immediately – following the instructions in the corresponding stage – and other pieces that you should store safely to one side, for use in future assembly stages.

Left and Right! When building your Mercedes-Benz 300SL, the left or right hand side refers to each side as you are sitting in the car.



WARNING: Some parts are assembled using magnets. These magnets can cause serious injury if they are swallowed. Keep away from children. If you suspect a magnet has been swallowed, seek medical help straight away.

■ STAGE 57: THE LEFT DOOR

With this stage you receive the left door, with a pre-fitted handle and lock.

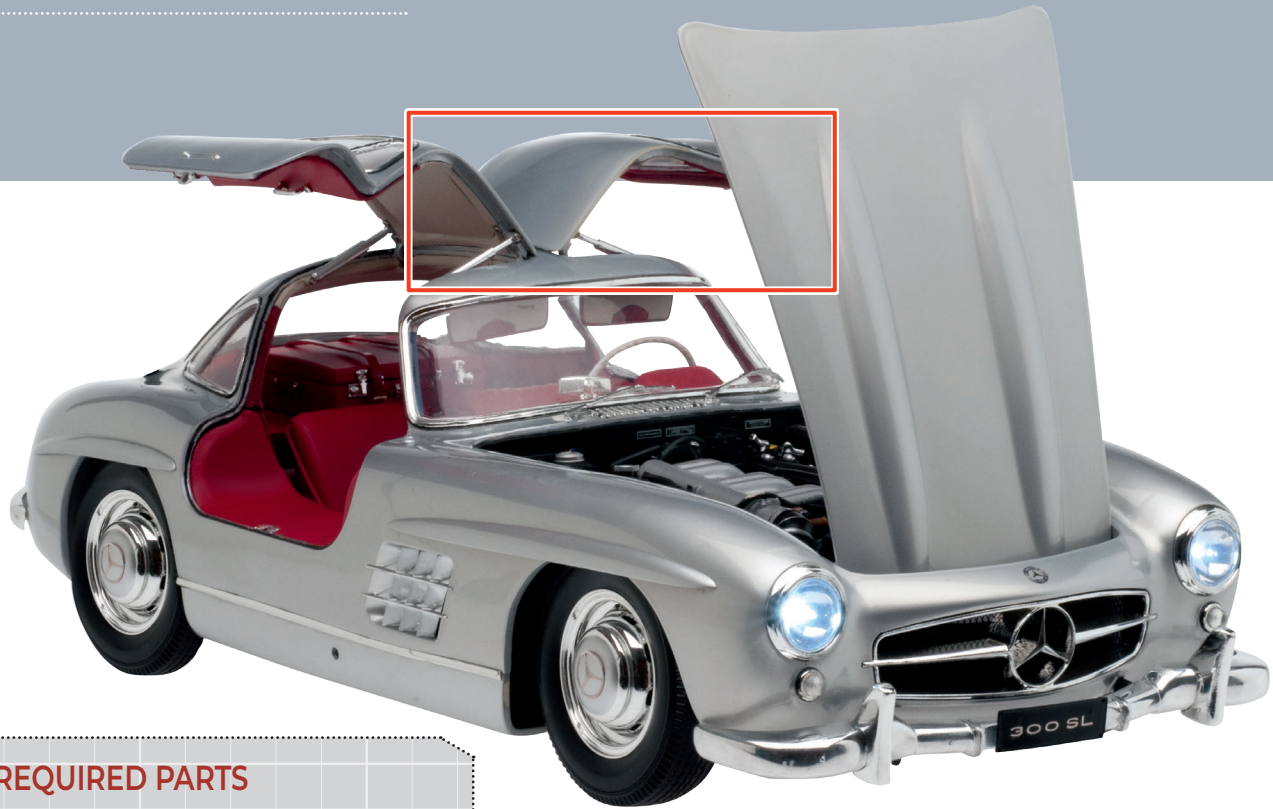

STAGE 57 – REQUIRED PARTS

Code	Name	Quantity	Material
57A	Left door	1	Zinc and ABS



In stage 58 you will fit the left door headliner and window.



STAGE 58: THE LEFT DOOR HEADLINER AND WINDOW

Fit the left door headliner and the left window, with its pre-fitted quarter light complete with hinge and handle.

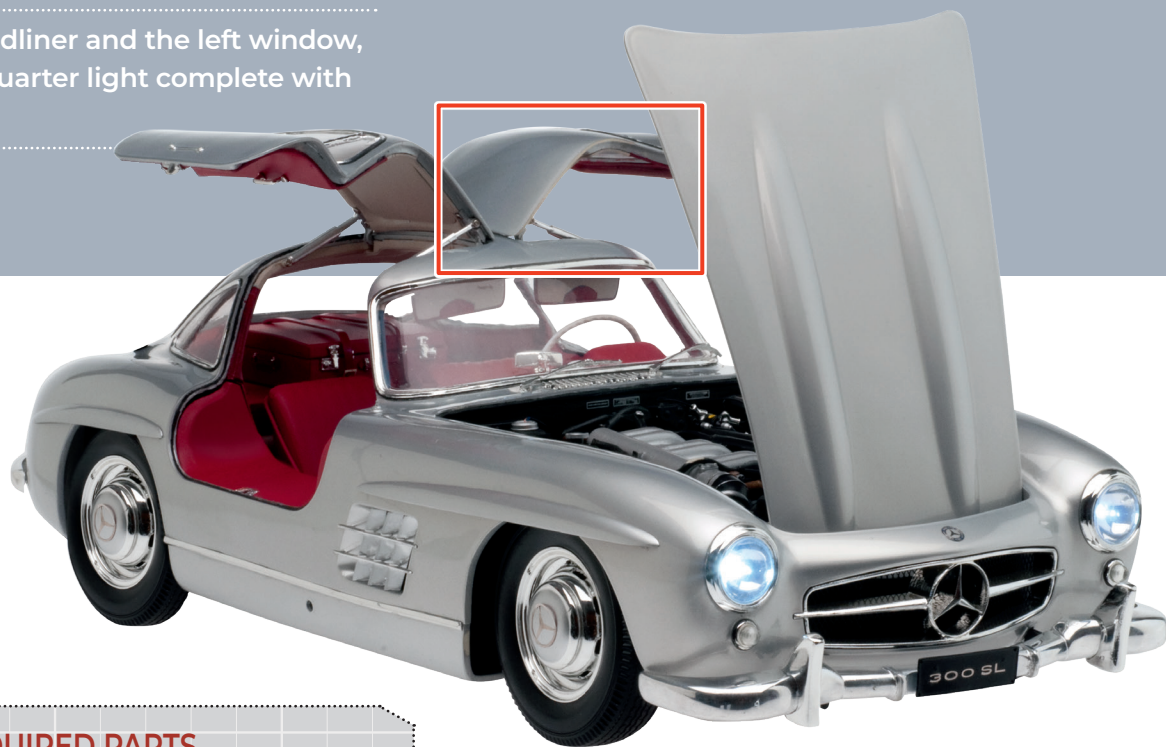

STAGE 58 – REQUIRED PARTS

Code	Name	Quantity	Material
58A	Left door headliner	1	ABS
58B	Left window	1	SAN and ABS
CM	Screws 2 x 4mm	2+1*	Iron

* Replacement screws included



01 FITTING THE LEFT DOOR HEADLINER

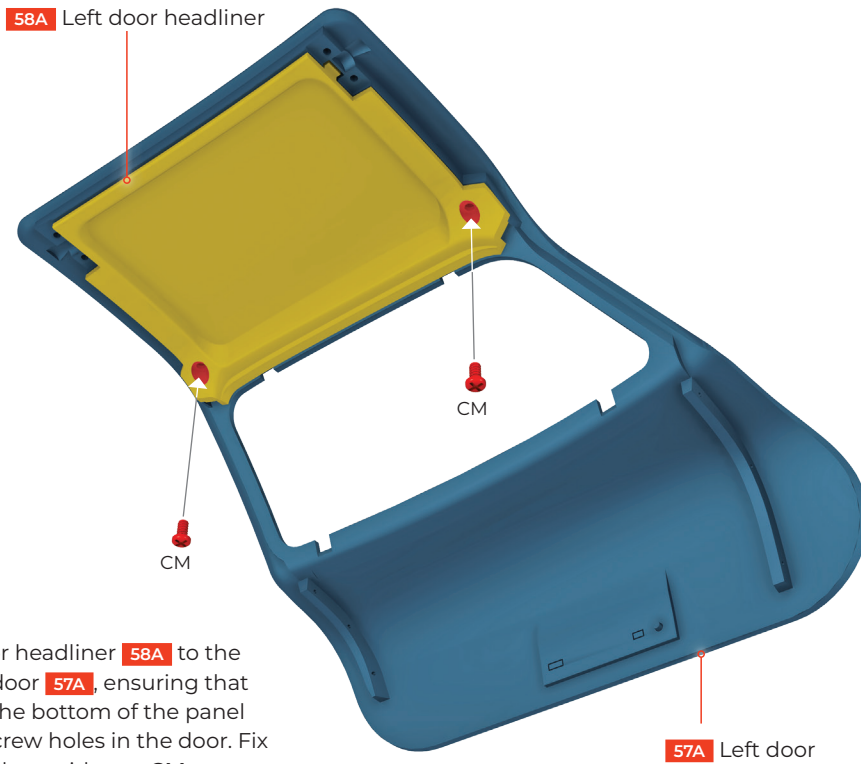

Fit the left door headliner **58A** to the inside of the left door **57A**, ensuring that the two holes at the bottom of the panel fit over the two screw holes in the door. Fix the headliner in place with two **CM** screws.

Work on a soft cloth to avoid scratching the paintwork on the roof and main body shell, and wear surgical gloves to avoid getting fingerprints on the windows.

02 FITTING THE WINDOW

Fit the two tabs on the top edge of the left window **58B** into the corresponding cutouts in the frame of the left door **57A**. Then clip the bottom tabs of the window firmly into the cutouts in the lower part of the frame.

IMPORTANT: Press against the edge of the main window frame and not against the quarter light window, which is fragile.

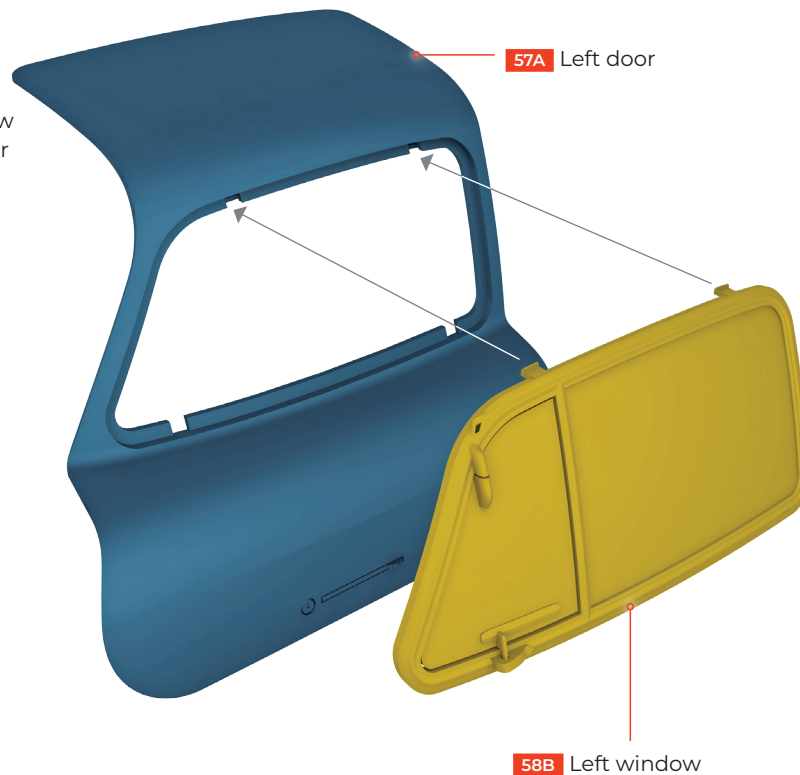

STAGE 59: THE LEFT DOOR INNER PANEL

Fit the left door inner panel, with its pre-fitted window lock, grab handle, and door locking mechanism.



COLOR CODING

The color coding of the parts shows how they should be put together.

RED indicates the screws and the correct position.



YELLOW indicates new parts.

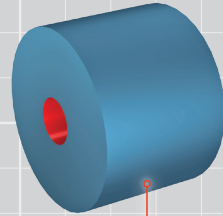

GRAY-BLUE indicates the modules on which the new parts should be assembled.

STAGE 59 - REQUIRED PARTS

Code	Name	Quantity	Material
59A	Left door inner panel	1	ABS
JM	Screws 1.5 x 3mm	6 + 2*	Iron

* Replacement screws included



01 FITTING THE LEFT DOOR INNER PANEL

Fit the left door inner panel **59A** to the inside of the left door **57A**. Ensure that the two tabs at the top of the inner panel fit into the slots on the bottom corners of the left door headliner **58A**. Fix with three **JM** screws through the front edge and with three **JM** screws through the rear edge of the inner panel (figure 1).

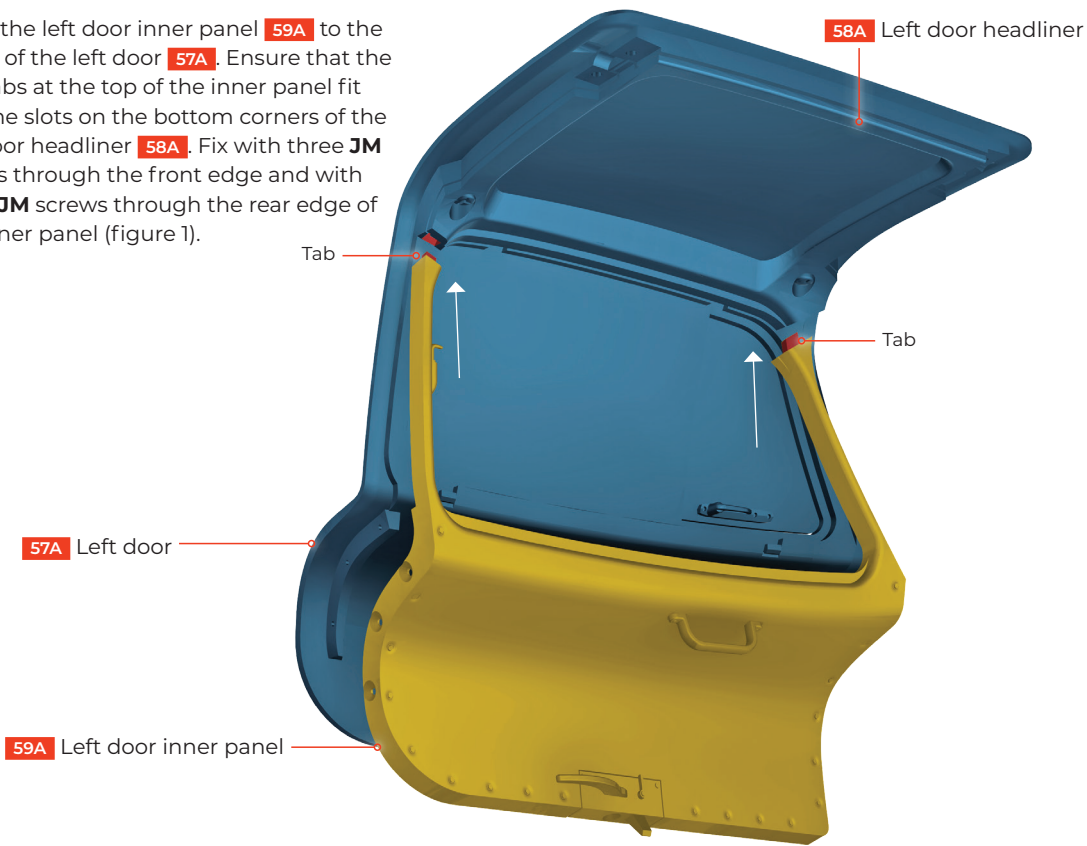

Work on a soft cloth to avoid scratching the paintwork.

Fig. 1

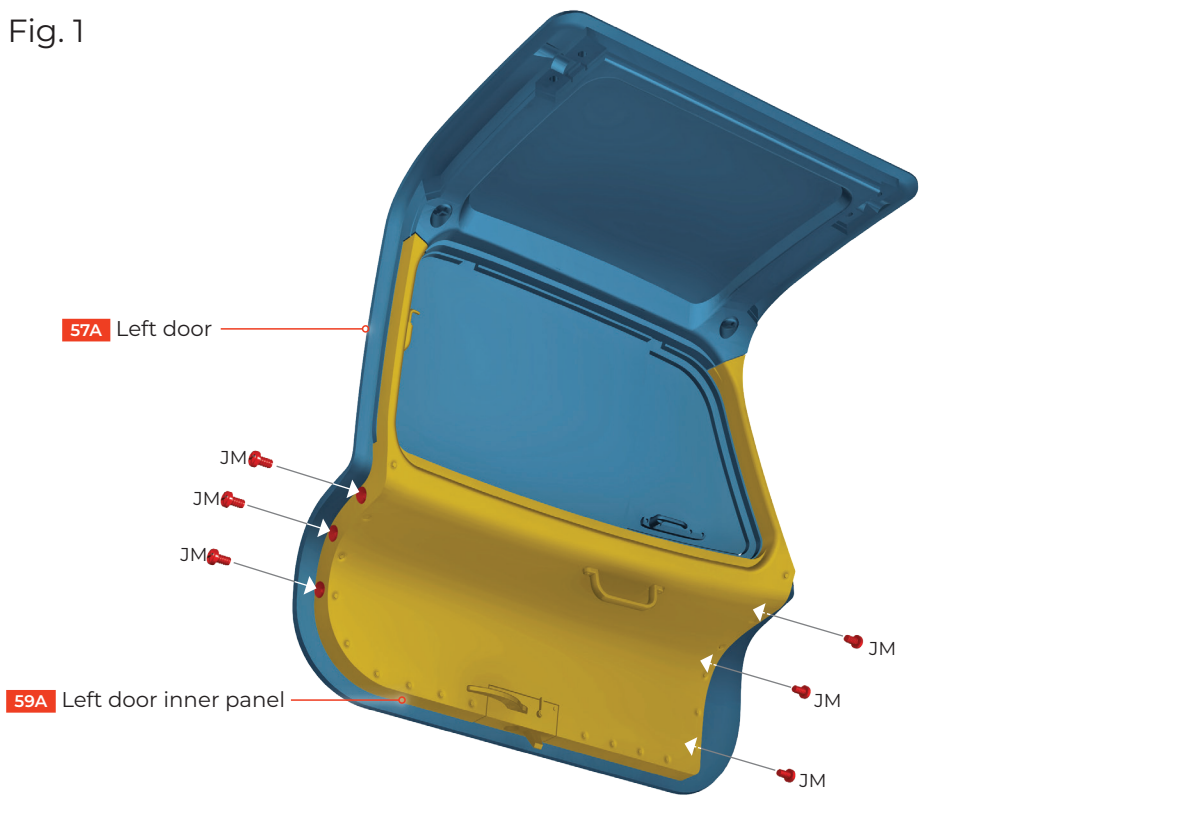

STAGE 60: THE RIGHT DOOR

With this stage you receive the right door,
with its pre-fitted handle and lock.



STAGE 60 - REQUIRED PARTS

Code	Name	Quantity	Material
60A	Right door	1	Zinc and ABS

60A



In stages 61 and 62 you will fit the right door inner panel, headliner, and window.



STAGE 61: THE RIGHT DOOR HEADLINER AND WINDOW

Fit the right door headliner and the right window with its pre-fitted quarter light, hinge, and handle.

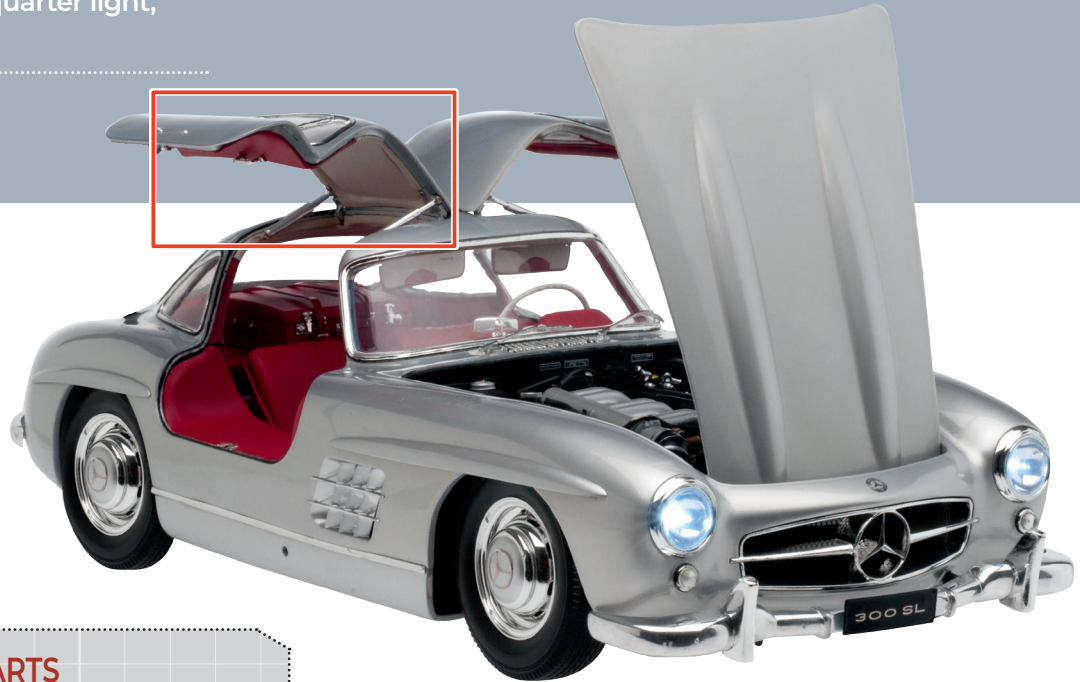

STAGE 61 – REQUIRED PARTS

Code	Name	Quantity	Material
61A	Right door headliner	1	ABS
61B	Right window	1	SAN and ABS
CM	Screws 2 x 4mm	2+1*	Iron

* Replacement screws included



01 FITTING THE RIGHT DOOR HEADLINER

Fit the right door headliner **61A** to the inside of the right door **60A**, ensuring that the two holes at the bottom of the panel fit over the two screw holes in the door. Fix the headliner in place with two **CM** screws.

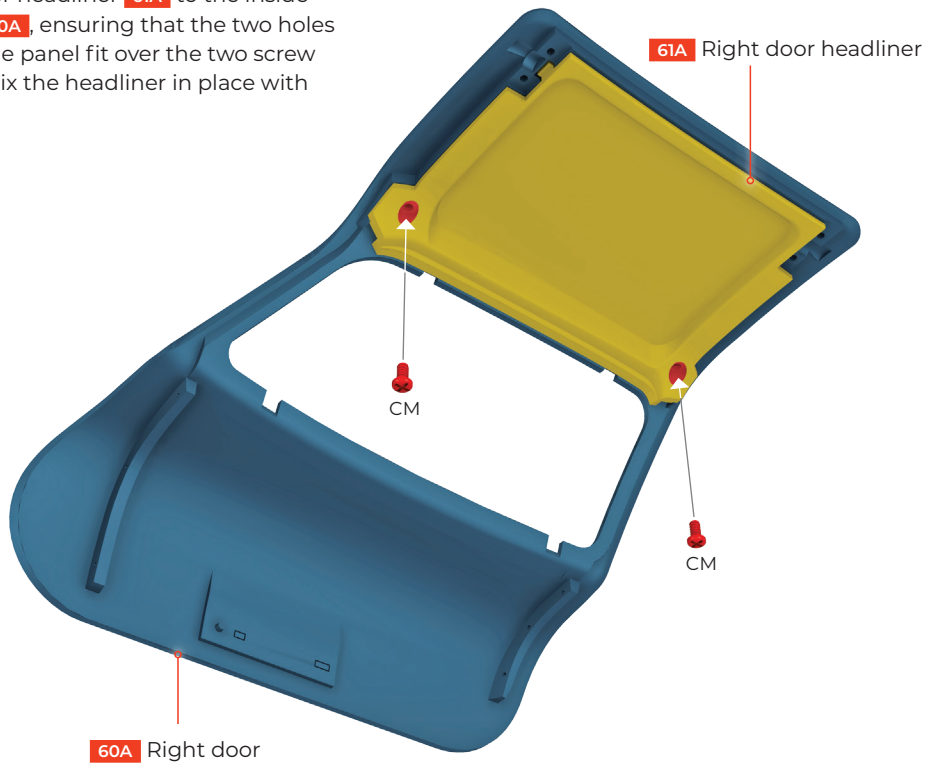

Work on a soft cloth to avoid scratching the paintwork on the roof and main body shell, and wear surgical gloves to avoid getting fingerprints on the windows.

02 FITTING THE WINDOW

Fit the two tabs on the top edge of the right window **61B** into the corresponding cutouts in the frame of the right door **60A**. Then clip the bottom tabs of the window firmly into the cutouts in the lower part of the frame.

IMPORTANT: Press against the edge of the main window frame and not against the quarter light window, which is fragile.

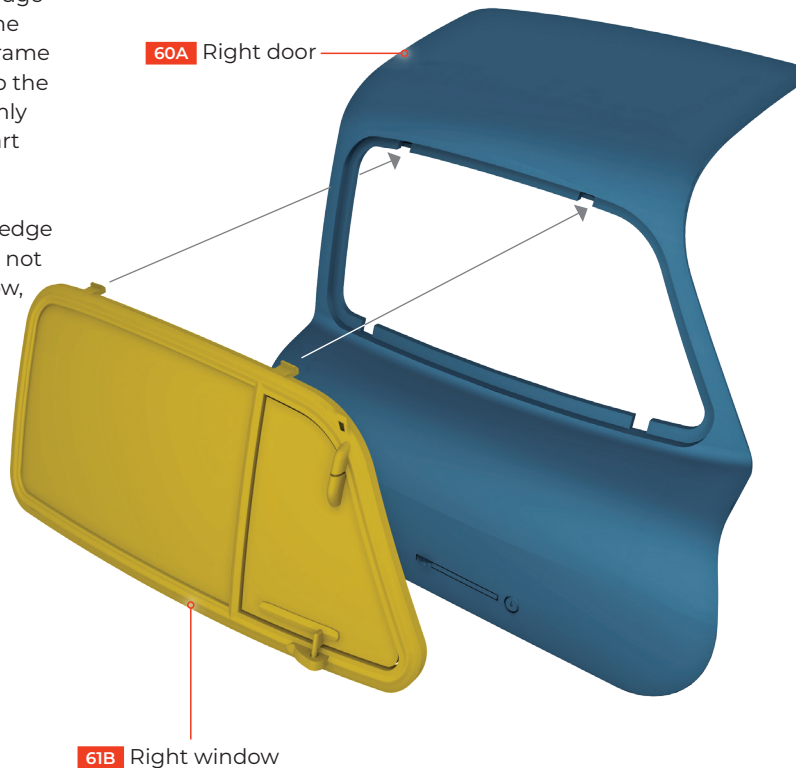

■ STAGE 62: THE RIGHT DOOR INNER PANEL

Fit the right door inner panel with its pre-fitted window lock, grab handle, and door locking mechanism.



STAGE 62 - REQUIRED PARTS

Code	Name	Quantity	Material
62A	Right door inner panel	1	ABS
JM	Screws 1.5 x 3mm	6+2*	Iron

* Replacement screws included

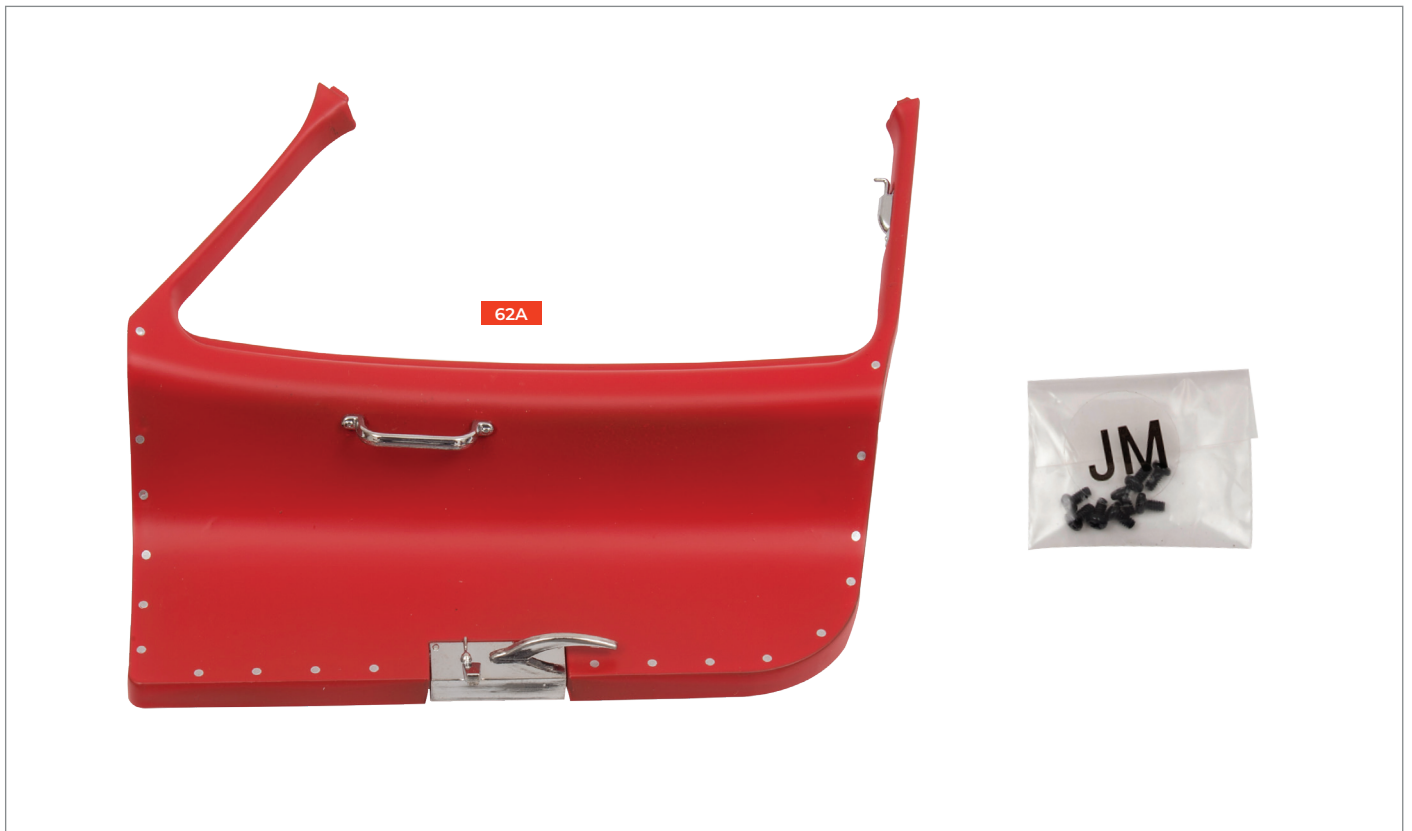

01 FITTING THE RIGHT DOOR INNER PANEL

Fit the right door inner panel **62A** to the inside of the right door **60A**. Ensure that the two tabs at the top of the inner panel fit into the slots on the bottom corners of the right door headliner **61A**. Fix with three **JM** screws through the front edge and with three **JM** screws through the rear edge of the inner panel (figure 1).

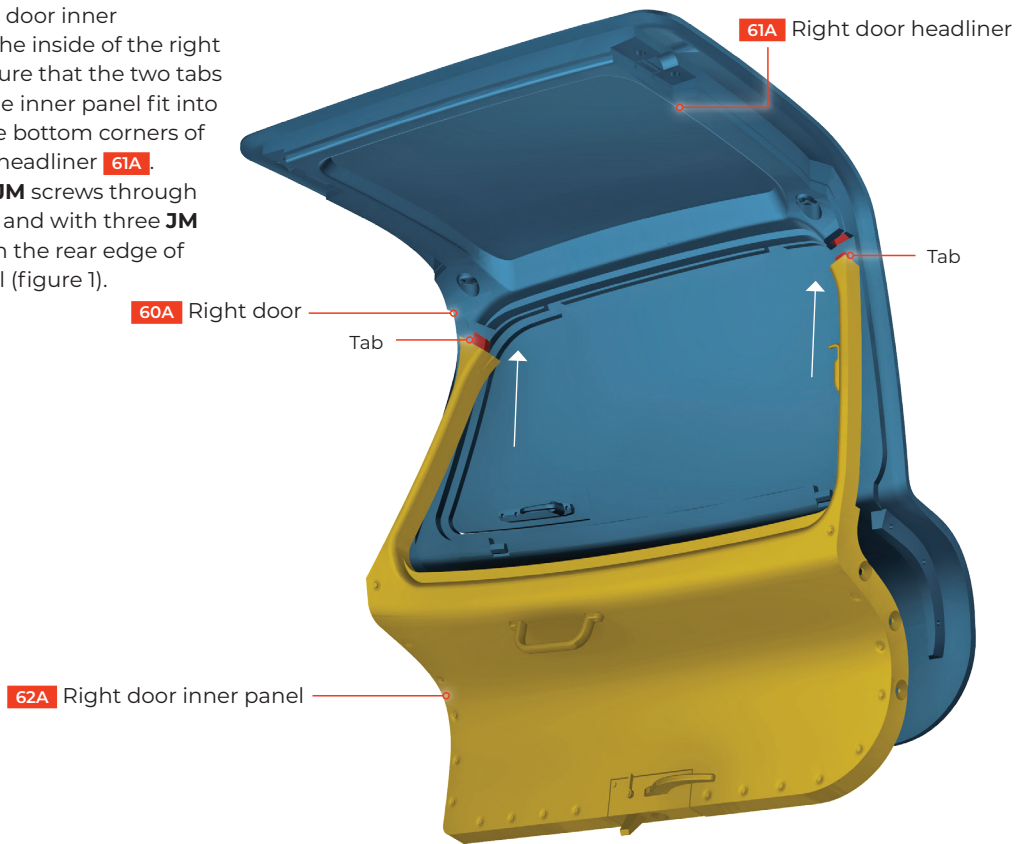

Work on a soft cloth to avoid scratching the paintwork.

Fig. 1

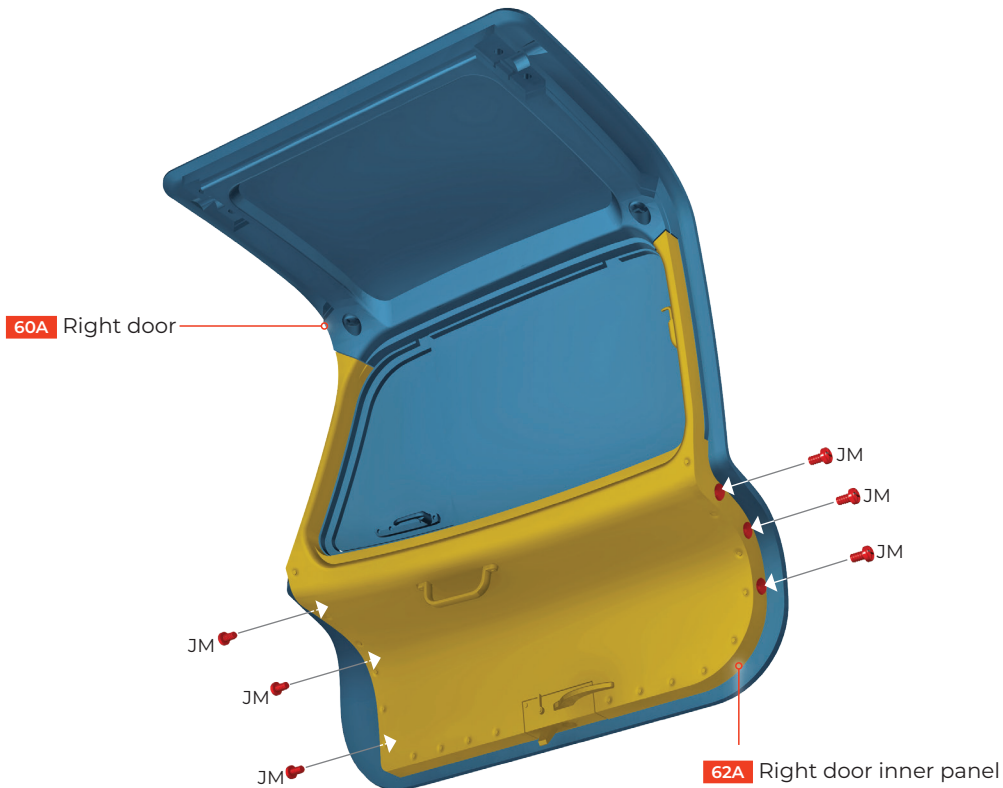

STAGE 63: THE DOOR'S HINGES

Fit the hinge cylinder pistons, then fit the left and right doors to the roof with hinges and cover plates.

STAGE 63: REQUIRED PARTS

Code	Name	Quantity	Material
63A	Left door front hinge (L4)	1	Zinc
63B	Left door rear hinge (L1)	1	Zinc
63C	Right door front hinge (R3)	1	Zinc
63D	Right door rear hinge (R2)	1	Zinc
63E	Hinge cylinder piston	4	Zinc
63F	Hinge cover plate	2	Iron
BM	Screws 1.7 x 4mm	4 + 2*	Iron
CM	Screws 2 x 4mm	8 + 3*	Iron
NM	Screws 2.3 x 3 x 6mm	2 + 1*	Iron

* Replacement screws included

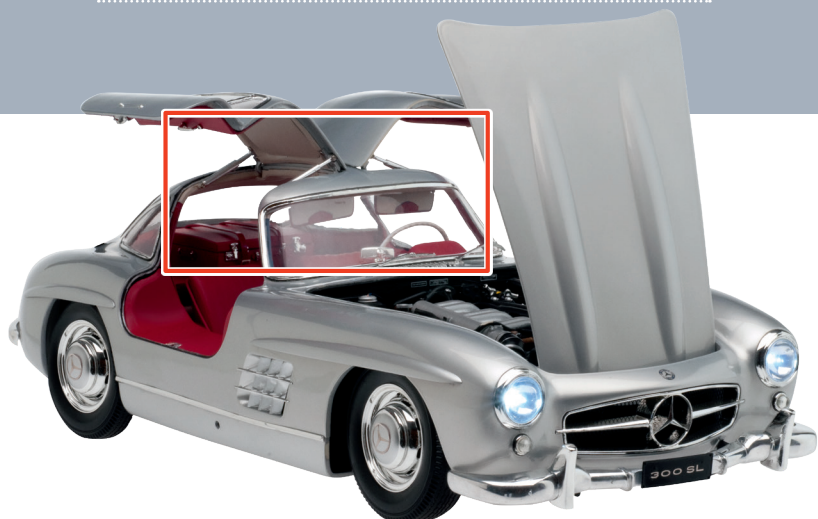

01 FITTING THE HINGE CYLINDER PISTONS

Align the screw eye at the end of one of the hinge cylinder pistons **63E** with the socket on the side of the left door front hinge (marked L4) **63A** and fix with a **BM** screw. Repeat for the remaining three hinge cylinder pistons **63E**, fixing each with a **BM** screw into the left door rear hinge (L1) **63B**, right door front hinge (R3) **63C**, and right door rear hinge (R2) **63D**.

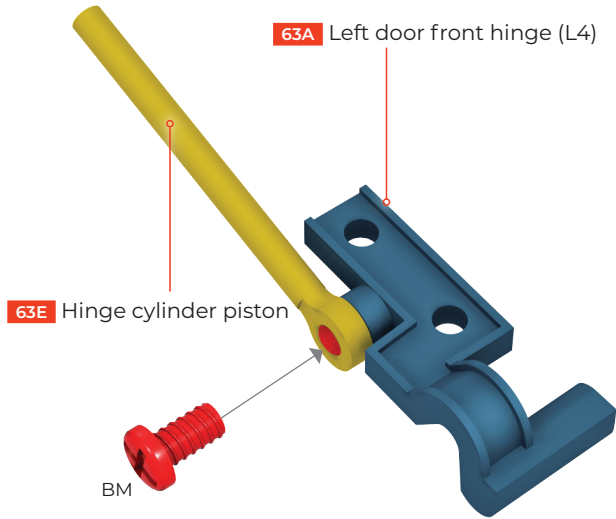

COLOR CODING

The color coding of the parts shows how they should be put together.

RED indicates the screws and the correct position.

YELLOW indicates new parts.

GRAY-BLUE indicates the modules on which the new parts should be assembled.

02 FITTING THE LEFT DOOR HINGES

Fit the left door **57A** into the door frame of the main body shell **56A** and roof **52A**, from the outside. Turn the assembly carefully upside down. Fit the left door front hinge (L4) **63A** to the two screw posts at the top front of the door, ensuring that the hinge cylinder piston **63E** is on the outside edge of the door. Fix in place with two **CM** screws (figure 1). Fit the left door rear hinge (L1) **63B** to the two screw posts at the top rear of the door and fix with two **CM** screws (figure 2).

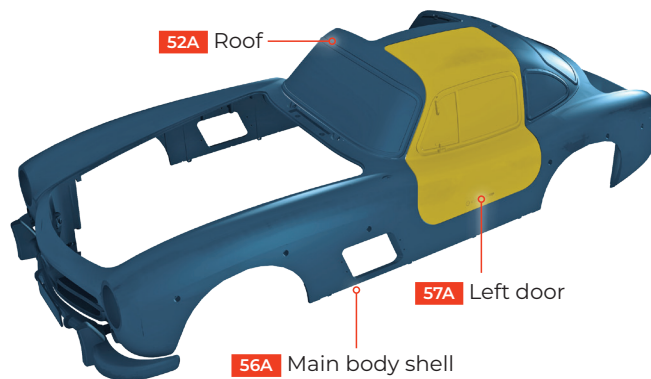

Fig. 1

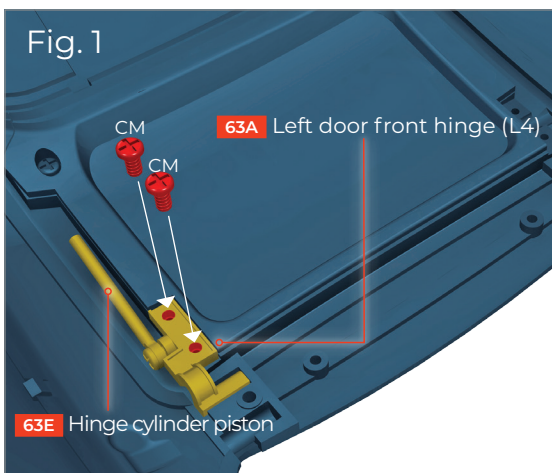
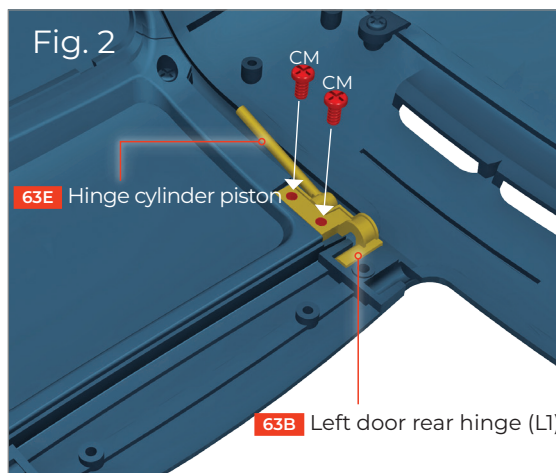

Fig. 2



Work on a soft cloth to avoid scratching the paintwork.

03 FITTING THE RIGHT DOOR HINGES

Fit the right door **60A** into the door frame of the main body shell **56A** and roof **52A** from the outside. Fit the right door front hinge (R3) **63C** to the two screw posts at the top front of the door, ensuring that the hinge cylinder piston **63E** is on the outside edge of the door. Fix with two **CM** screws (figure 1). Fit the right door rear hinge (R2) **63D** to the two screw posts at the top rear of the door and fix with two **CM** screws (figure 2).

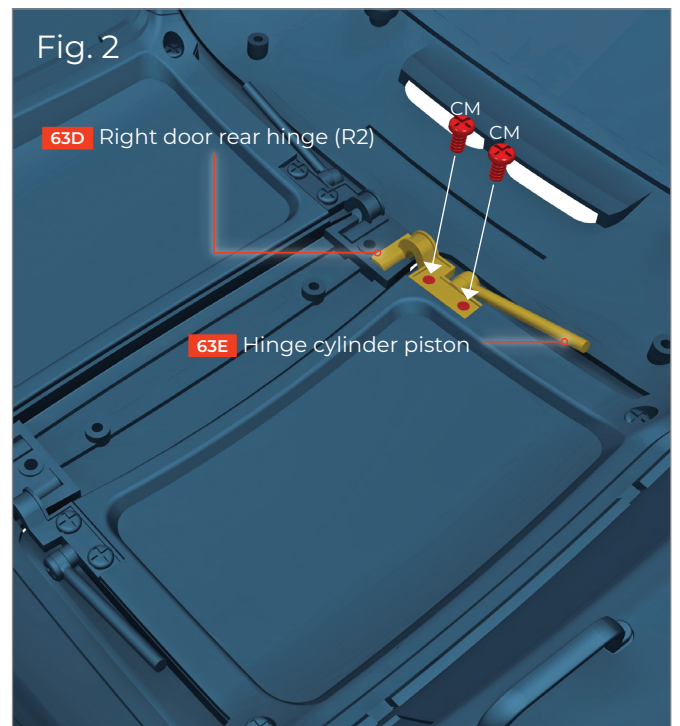
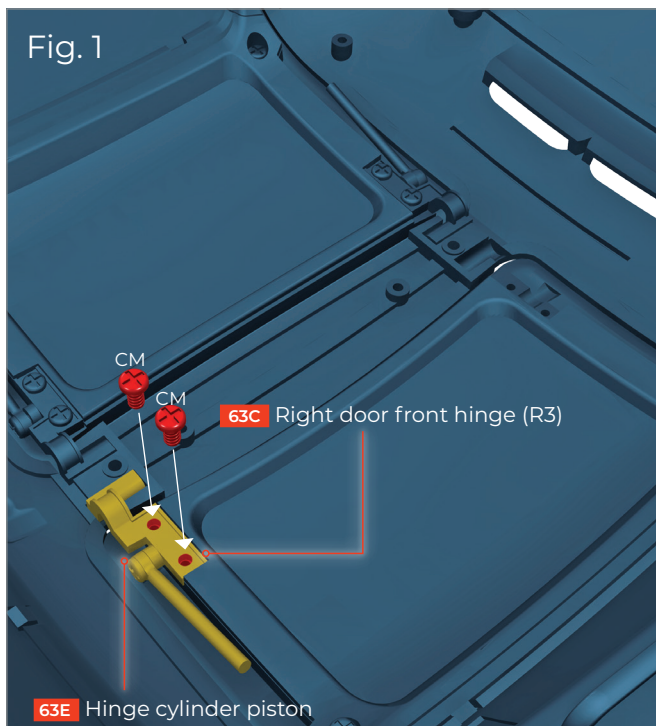
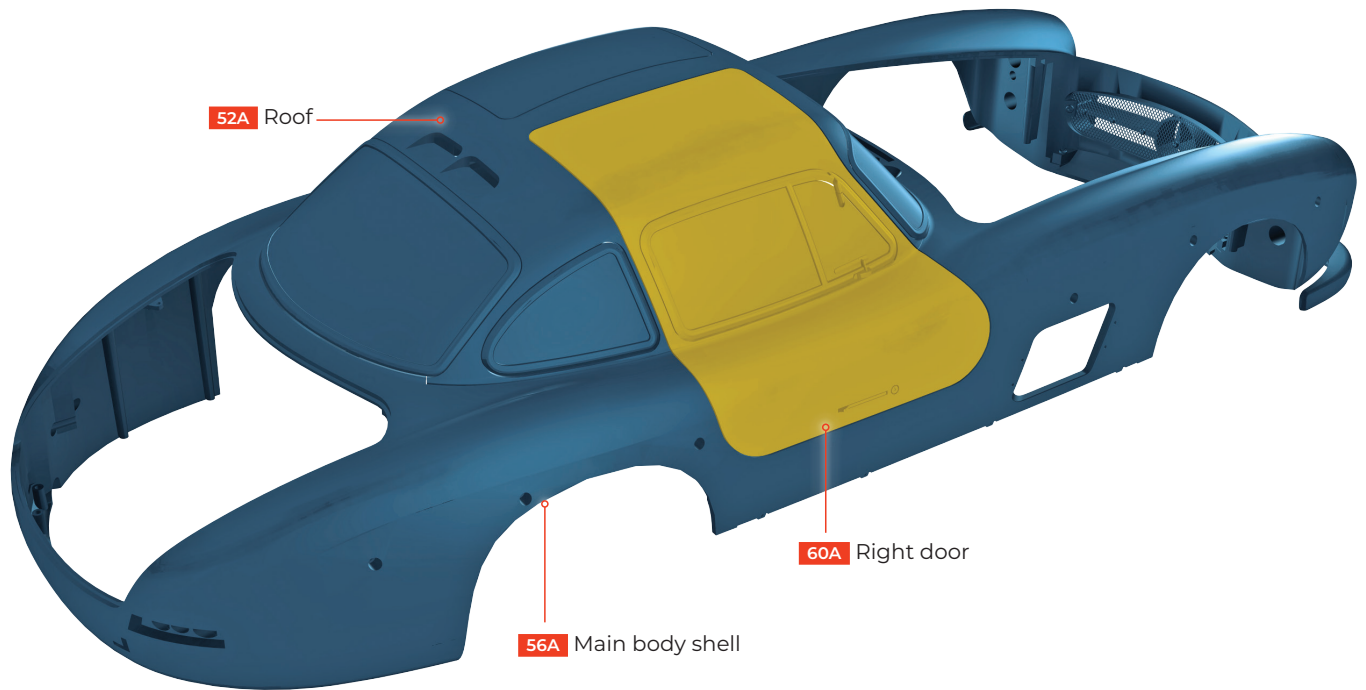

04 FITTING THE HINGE COVER PLATES

Fit one of the hinge cover plates **63F** over the screw post of the left door front hinge (L4) **63A** and the right door front hinge (R3) **63C**, positioned as shown. Fix very firmly with an **NM** screw to ensure that the plate is tight against the hinge screw post. Fit the second hinge cover plate **63F** over the screw post of the left door rear hinge (L1) **63B** and the right door rear hinge (R2) **63D**, and fix very firmly with an **NM** screw (figure 1). Turn the assembly upright and gently check that the doors open upwards, with the hinge plates providing just enough resistance to hold the weight of the door when open. If necessary, tighten the **NM** screws holding the hinge plates in place (figure 2). Adjust the screws as needed so that the doors close flush with the body.

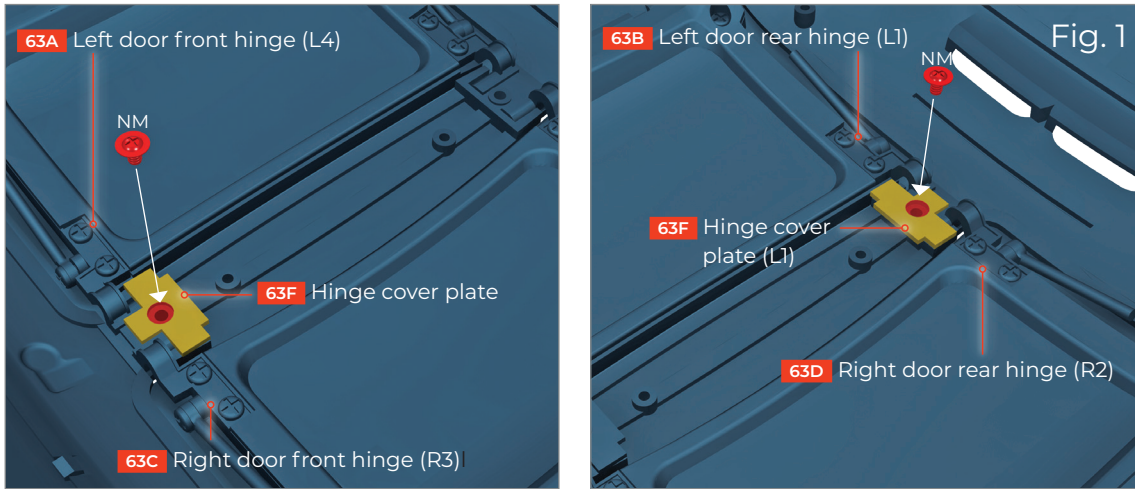

Fig. 2

