



E-TYPE



Pack 01

BUILD INSTRUCTIONS

**STAGE 01: ASSEMBLING THE CYLINDER HEAD
AND CAM COVERS**

STAGE 02: ASSEMBLING THE CARBURETTOR

STAGE 03: ASSEMBLING THE CARBURETTOR 2

STAGE 04: ASSEMBLING THE ENGINE BLOCK 1

STAGE 05: ASSEMBLING THE ENGINE BLOCK 2

**STAGE 06: ASSEMBLING THE FAN BELT
AND ELECTRICS**

**STAGE 07: ASSEMBLING THE EXHAUSTS
AND IGNITION**

Advice from the experts

Spare screws are included with each part. Occasionally, you may be instructed to keep spare or unused screws for a later stage. Keep these spares in a safe place and label them correctly.

Please make sure you don't mix up the screws. They look quite similar, but the threads do vary slightly. Using the wrong screws may damage the parts.

When securing parts together using multiple screws, fit each screw loosely to ensure all the parts are correctly aligned before gently tightening them firmly, but not overtight, in the order in which you placed them.

The screwdriver can be magnetized by stroking it with a magnet (fridge magnet, etc.) enabling it to hold the screws and make assembly easier.

If a screw is tight going into a metal part, do not force it as you may shear the head off. Remove it and put a tiny smear of Vaseline, soap or light oil on the thread. That will lubricate it and make it easier to drive home.

During the course of this build, you will receive many pieces that you will assemble immediately – following the instructions in the corresponding stage – and other pieces that you should store safely to one side, for use in future assembly stages.

Left and Right! When building your Jaguar, the left or right hand side refers to each side as you are sitting in the car.



WARNING: Some parts are assembled using magnets. These magnets can cause serious injury if they are swallowed. Keep away from children. If you suspect a magnet has been swallowed, seek medical help straight away.

Stage 01: Assembling the Cylinder Head and Cam Covers

In this first stage of building the Jaguar E-type, you will start assembling the top of the remarkable 3.8 litre XK engine and the steering wheel.



STAGE 01 PARTS LIST

Name
Cylinder head
Steering wheel
Oil cap
Horn button
Inlet cam cover
Inlet camshaft
Exhaust camshaft
Exhaust cam cover
Screws type AG02 x 2

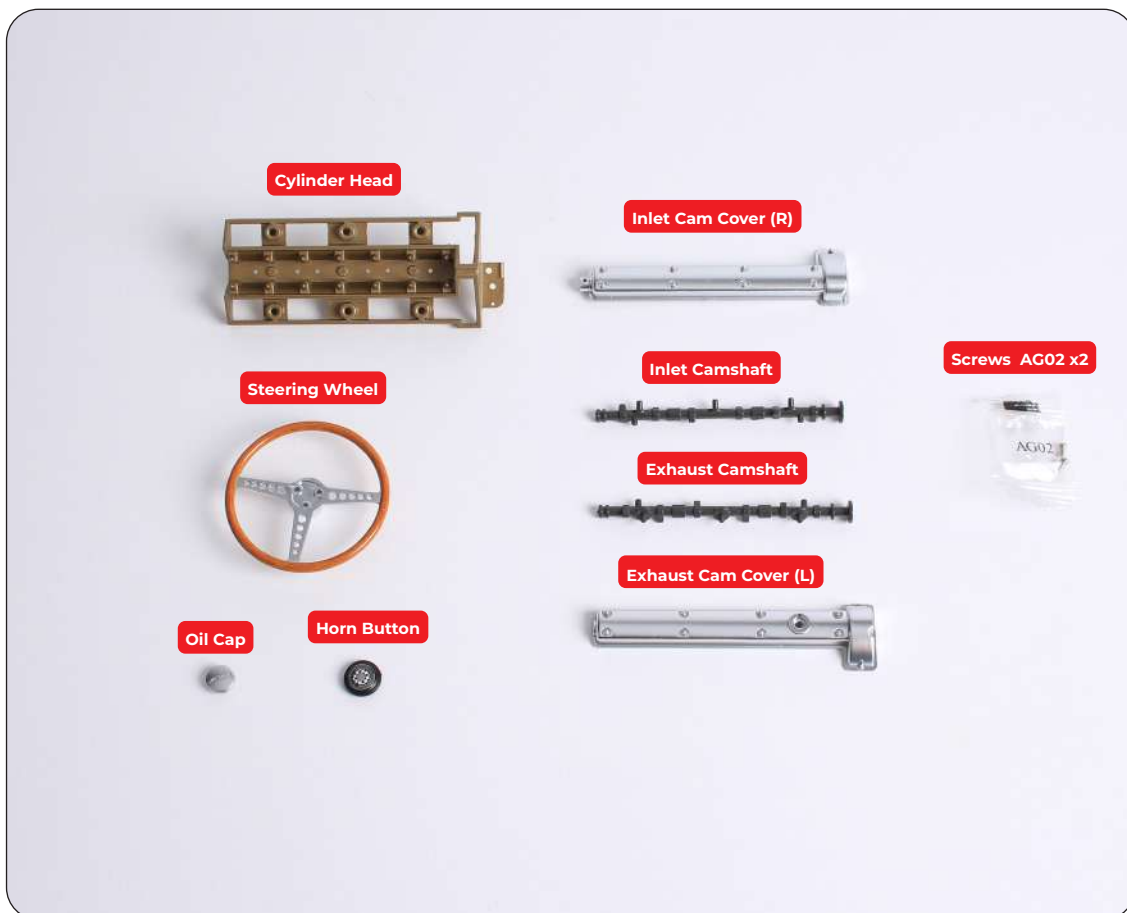

Stage 01: Assembling the Cylinder Head and Cam Covers

STEP 1



ASSEMBLE THE EXHAUST CAM COVER

Align the locating tab on the back of the oil cap with the shaped hole in the exhaust cam cover.



Place into position, checking that the Jaguar logo is horizontal as shown.



Secure in place from the reverse side using an AG02 screw.

Stage 01: Assembling the Cylinder Head and Cam Covers

STEP 2

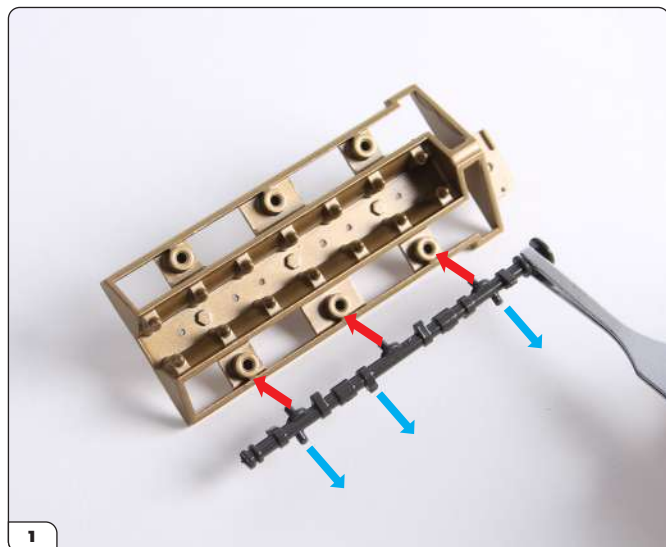

FIX THE INLET CAMSHAFT TO THE CYLINDER HEAD

The inlet camshaft is different to the exhaust camshaft so check you have the correct part. Align the three pins on the inlet camshaft with the corresponding holes on the cylinder head. The projections on the upper surface should angle outwards.

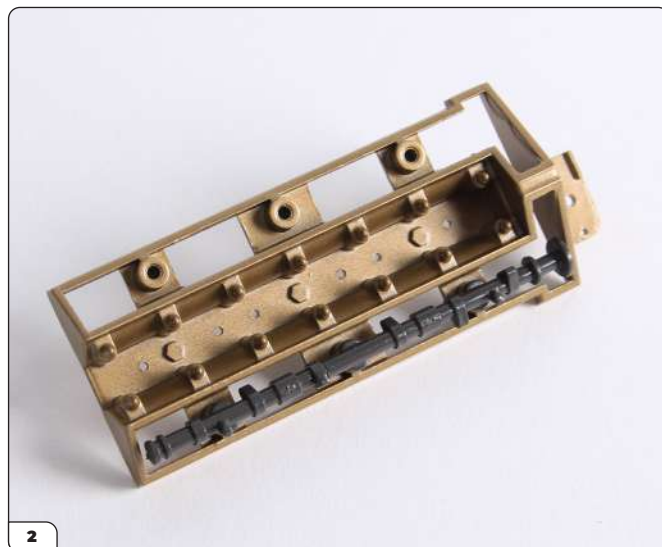

Fit in place.

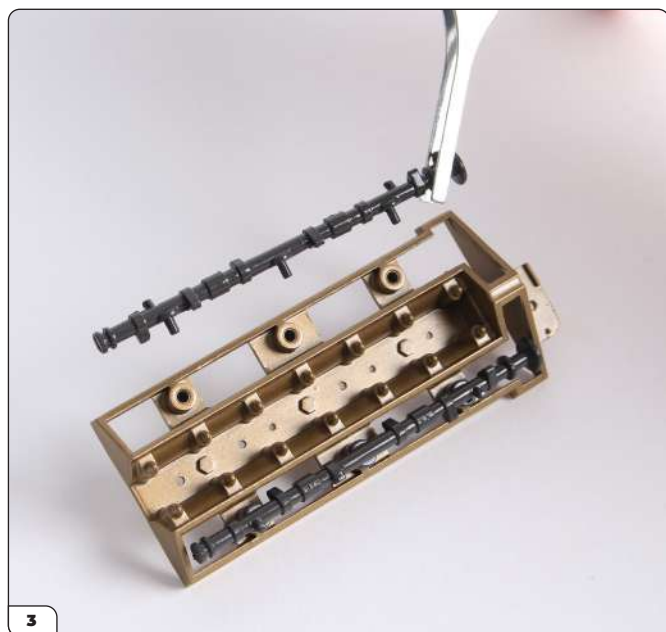

FIX THE EXHAUST CAMSHAFT TO THE CYLINDER HEAD

Align the three pins on the exhaust camshaft to the opposite side of the cylinder head so that the projections on the upper surface angle outwards.



Correct positioning of the camshafts.

Stage 01: Assembling the Cylinder Head and Cam Covers



FIX THE INLET CAM COVER TO THE CYLINDER HEAD

Align the two holes on the inlet cam cover with the two pins projecting from the cam shaft.



Press the cam cover firmly into place.



FIX THE EXHAUST CAM COVER TO THE CYLINDER HEAD

Align the two holes on the exhaust cam cover with the two pins projecting from the cam shaft.



Press firmly into place.

Stage 01: Assembling the Cylinder Head and Cam Covers

STEP 3



FIX THE HORN BUTTON TO THE STEERING WHEEL

Align the pins on the underside of the horn button with the corresponding holes on the steering wheel.



Press firmly into place, checking that the logo is correctly centred as shown.

STAGE COMPLETE

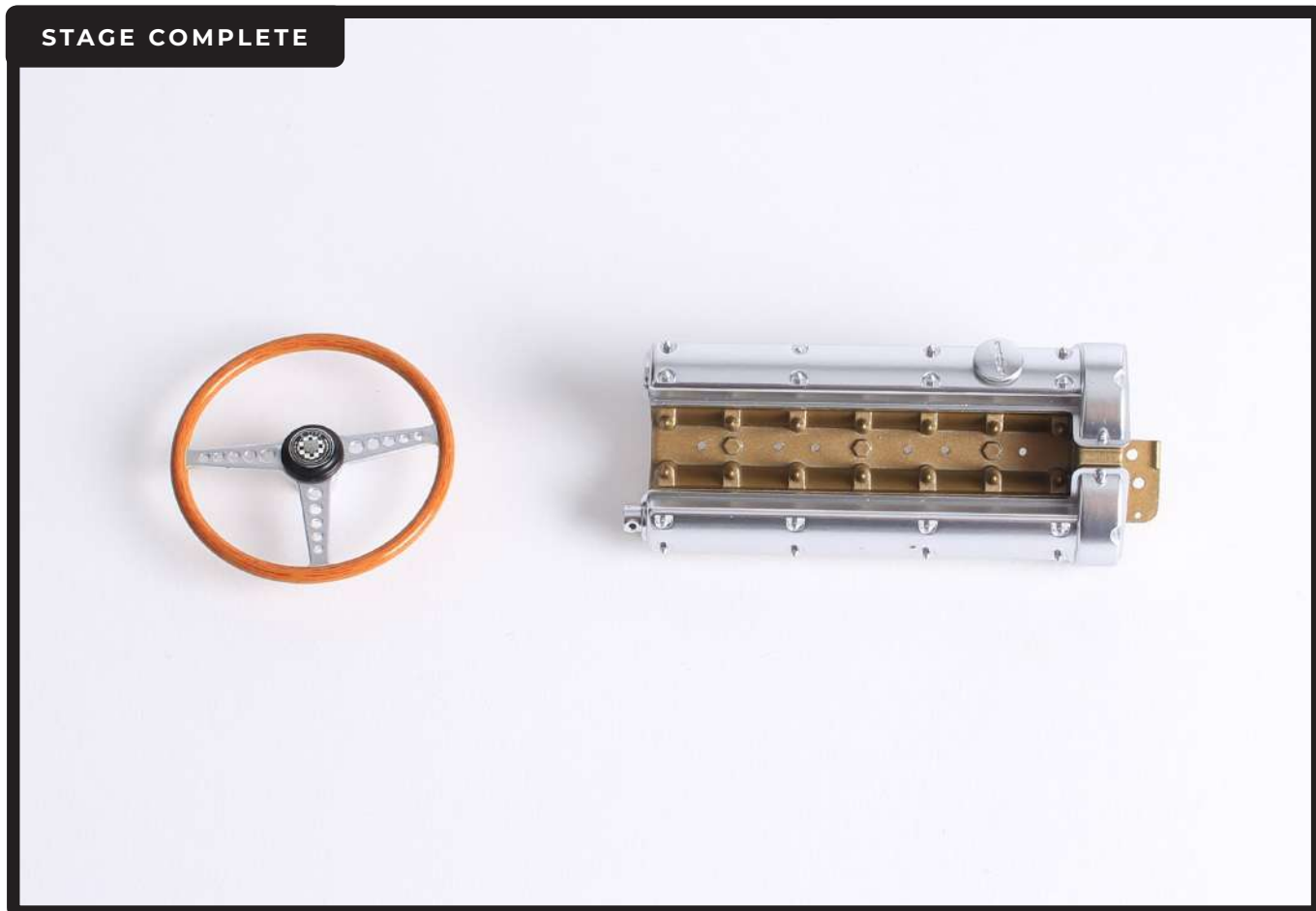

Stage 02: Assembling the Carburettor

In this second stage you'll continue to build the engine by starting to assemble the carburettor.



STAGE 02 PARTS LIST

Name
Manifold upper half
Throttle linkage
Shaft
Suction chambers x3
Screws type AG02 x3

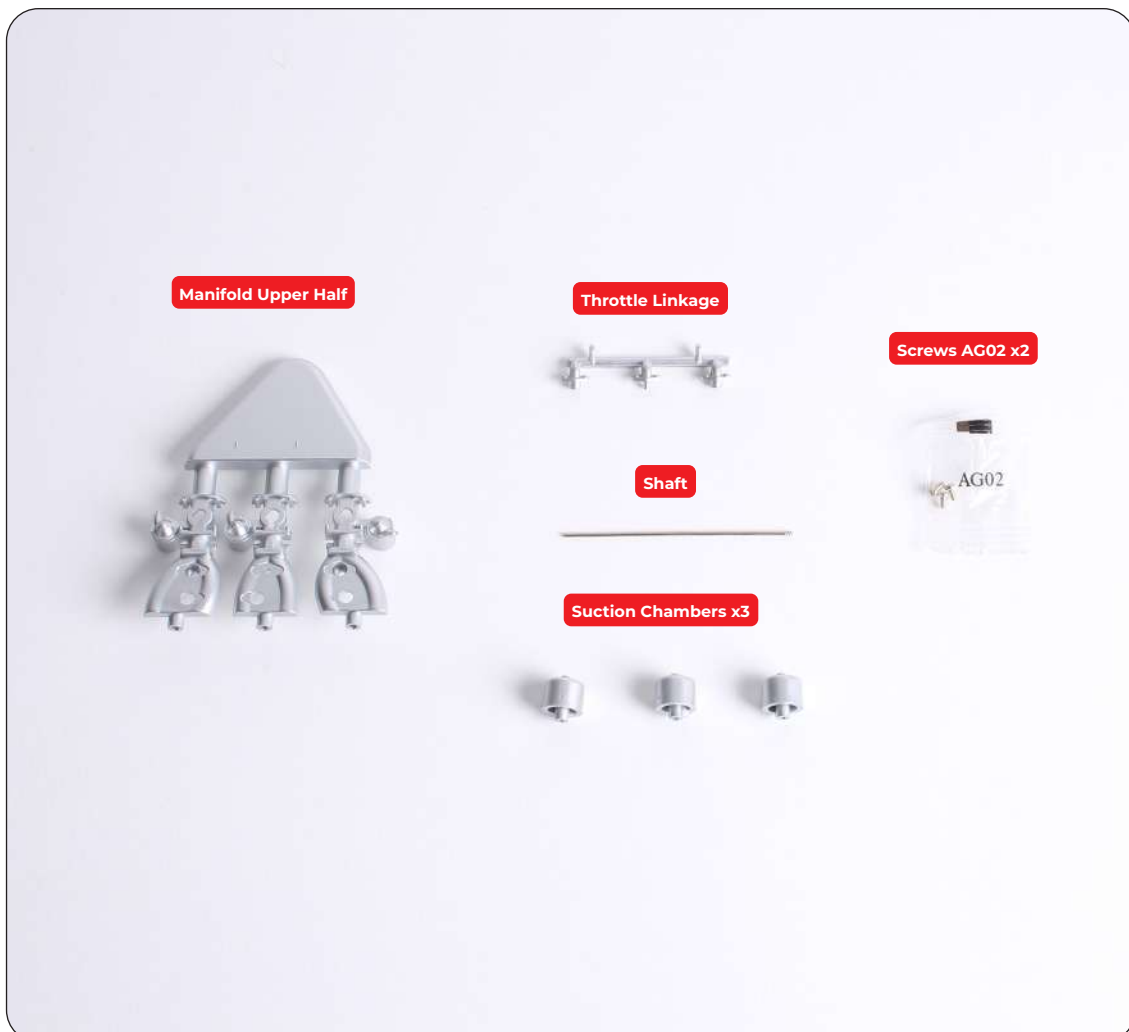

Stage 02: Assembling the Carburettor

STEP 1



ATTACH THE THROTTLE LINKAGE TO THE MANIFOLD
Align the three pins on the throttle linkage with the corresponding holes on the manifold as shown, then fit into place.

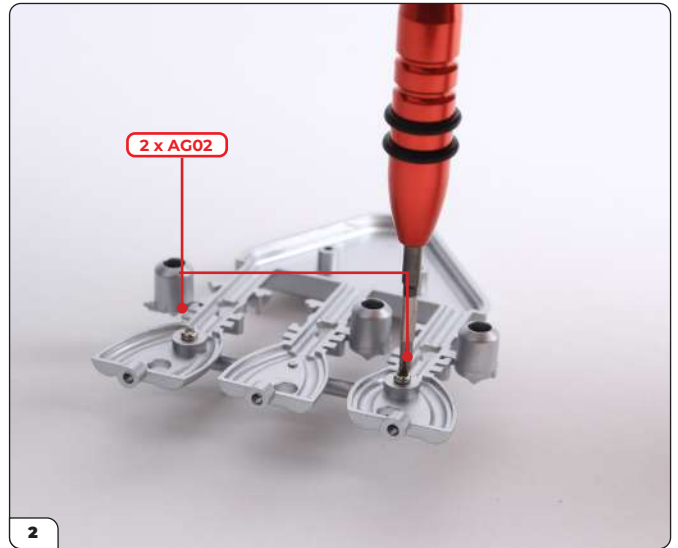

Secure from the reverse side using 2 x AG02 screws.



This shows how your assembly should look.

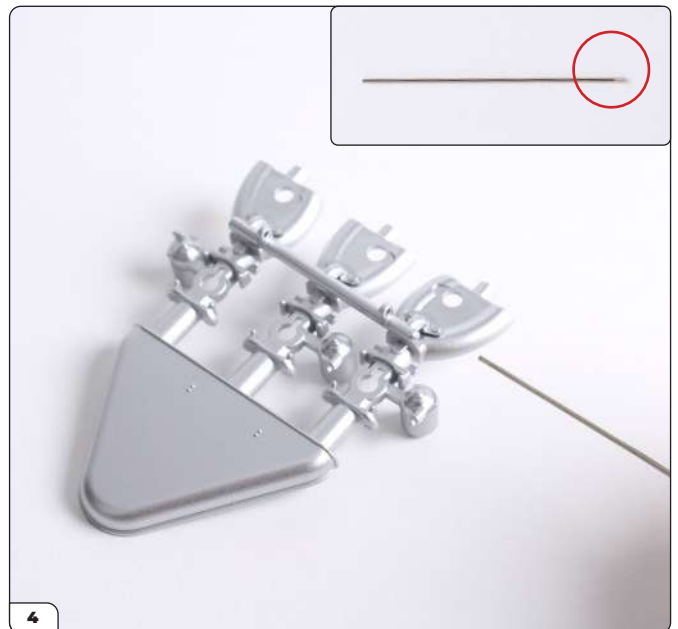

Take the shaft and note that one end has ridges (see inset). Feed the unridged end through the holes in the throttle linkage.

Stage 02: Assembling the Carburettor

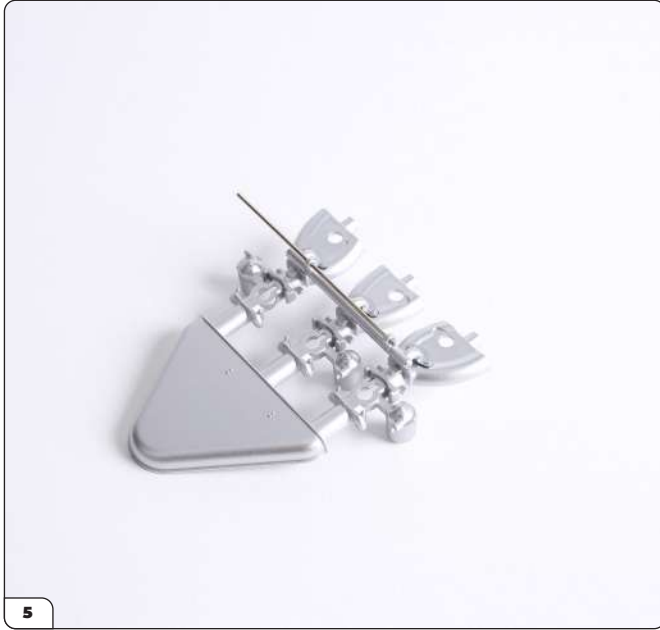

Push the shaft through the holes as far as it will go.

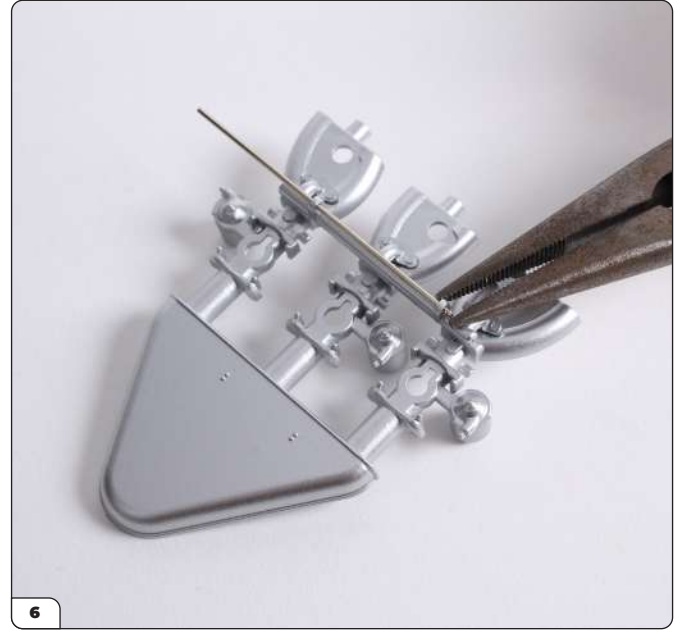

Using pliers, squeeze the ridged end of the shaft through the first small hole to anchor the shaft into position.



This shows how your assembly should look.



The three suction chambers will be used in the next stage. Keep them in a safe place until required. It is also a good idea to label and keep any unused screws in case you need spares at a later stage of the build!

Stage 03: Assembling the Carburettor 2

In this third stage you'll fit the rest of the carburettor.



STAGE 03 PARTS LIST

Name
Manifold lower half
Air cleaner
Petrol feed pipe
Air balance pipe
Screws type AG02 x7
Screws type AG03 x3



Stage 03: Assembling the Carburettor 2

STEP 1



ASSEMBLE THE CARBURETTOR

Align the fixings on the manifold lower half with the assembly from the previous stage.



Fix the two parts together using 2 x AG03 screws.



Take one of the suction chambers from the previous stage and press it into the key-shaped hole on the carburettor.



Fix in place from the reverse side using an AG02 screw.

Stage 03: Assembling the Carburettor 2



5 Repeat the process shown in 3 and 4 to fix the remaining two suction chambers using two more AG02 screws.



6 Align the three lugs on the air balance pipe with the three holes on the manifold and fit into position.



7 This shows the air balance pipe correctly positioned.



8 Fix into place from the reverse side using 3 x AG02 screws.

Stage 03: Assembling the Carburettor 2



Align the petrol feed pipe with the assembly as shown. There are three fixing points – see circled in the next picture.



Using tweezers, push the hole on the left hand side of the pipe over the projecting pin on the lower float bowl (1). Connect the central hole on the pipe to the pin on the central float bowl (2), and then connect the remaining union to the pin on the third float bowl at the right hand side (3). Apply a drop of superglue if necessary.

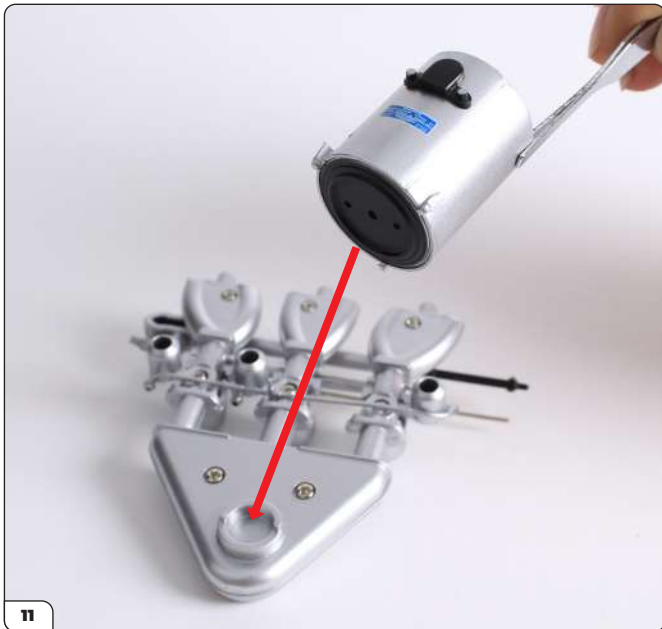

Align the air cleaner with the circular mounting on the manifold, noting the two fixing pins.



Press firmly into place.

Stage 03: Assembling the Carburettor 2

STAGE COMPLETE



Stage 04: Assembling the Engine Block 1

In this fourth stage you will assemble the engine block before fitting the carburettor.



STAGE 04 PARTS LIST

Name
Engine block and clutch bellhousing (Right)
Distributor
Starter motor
Screws type AG03 x6



Engine block and clutch bellhousing (R)

Distributor

Starter motor

Screws AG03 x6

Stage 04: Assembling the Engine Block 1

STEP 1



FIT THE STARTER MOTOR AND DISTRIBUTOR TO THE ENGINE BLOCK

Align the key-shaped fixing on the starter motor with the corresponding hole in the engine block.



Press into place.

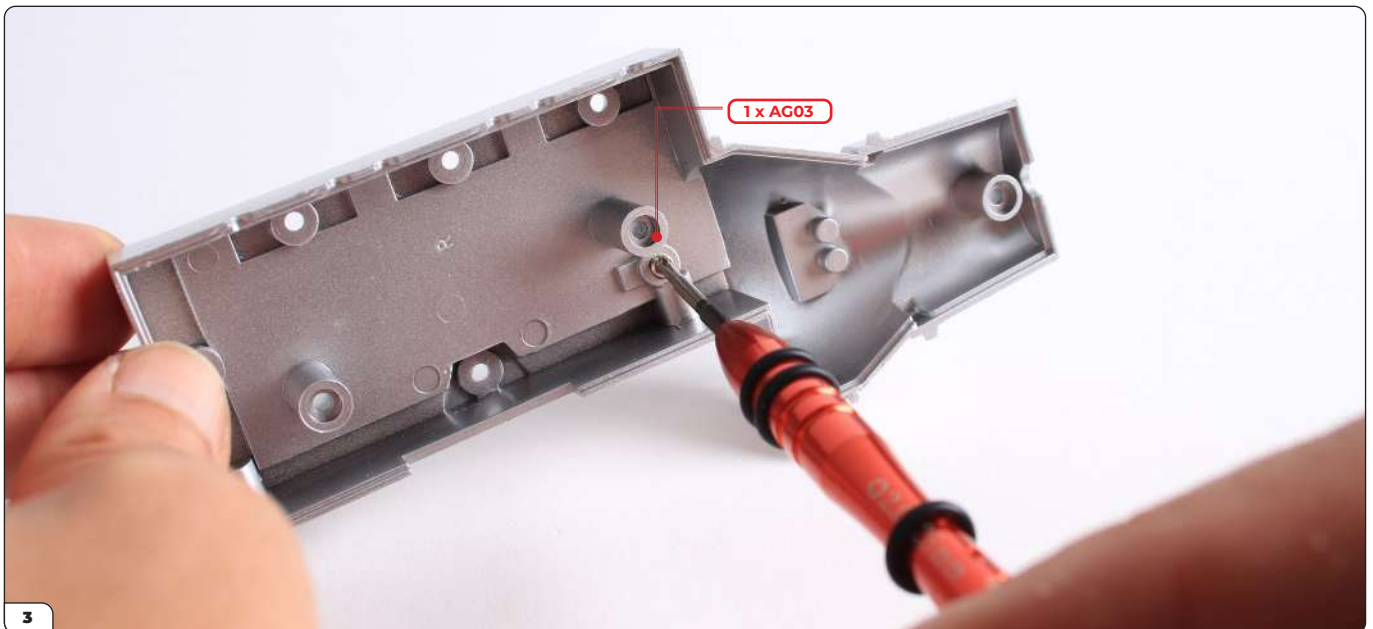

Fix in place from the reverse side using an AG03 screw.

Stage 04: Assembling the Engine Block 1



Align the key-shaped fixing on the distributor with the corresponding hole in the engine block.

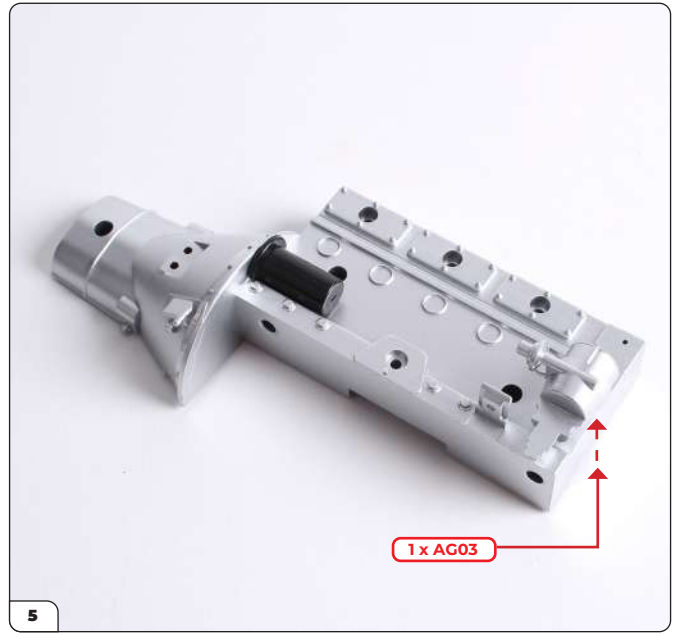

Press firmly into place. Secure from the underside using an AG03 screw.

STEP 2



ATTACH THE CARBURETOR ASSEMBLY TO THE ENGINE BLOCK

Align the three lugs on the inlet manifold with the corresponding holes in the engine block.

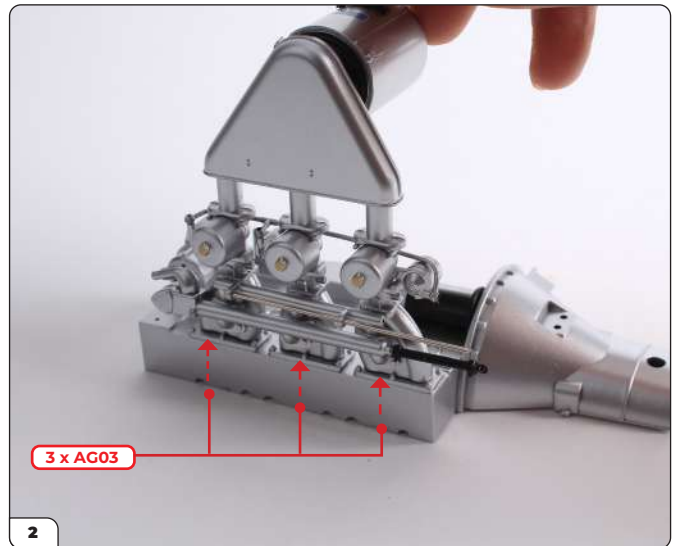

Fix in place from the reverse side using 3 x AG03 screws.

Stage 04: Assembling the Engine Block 1

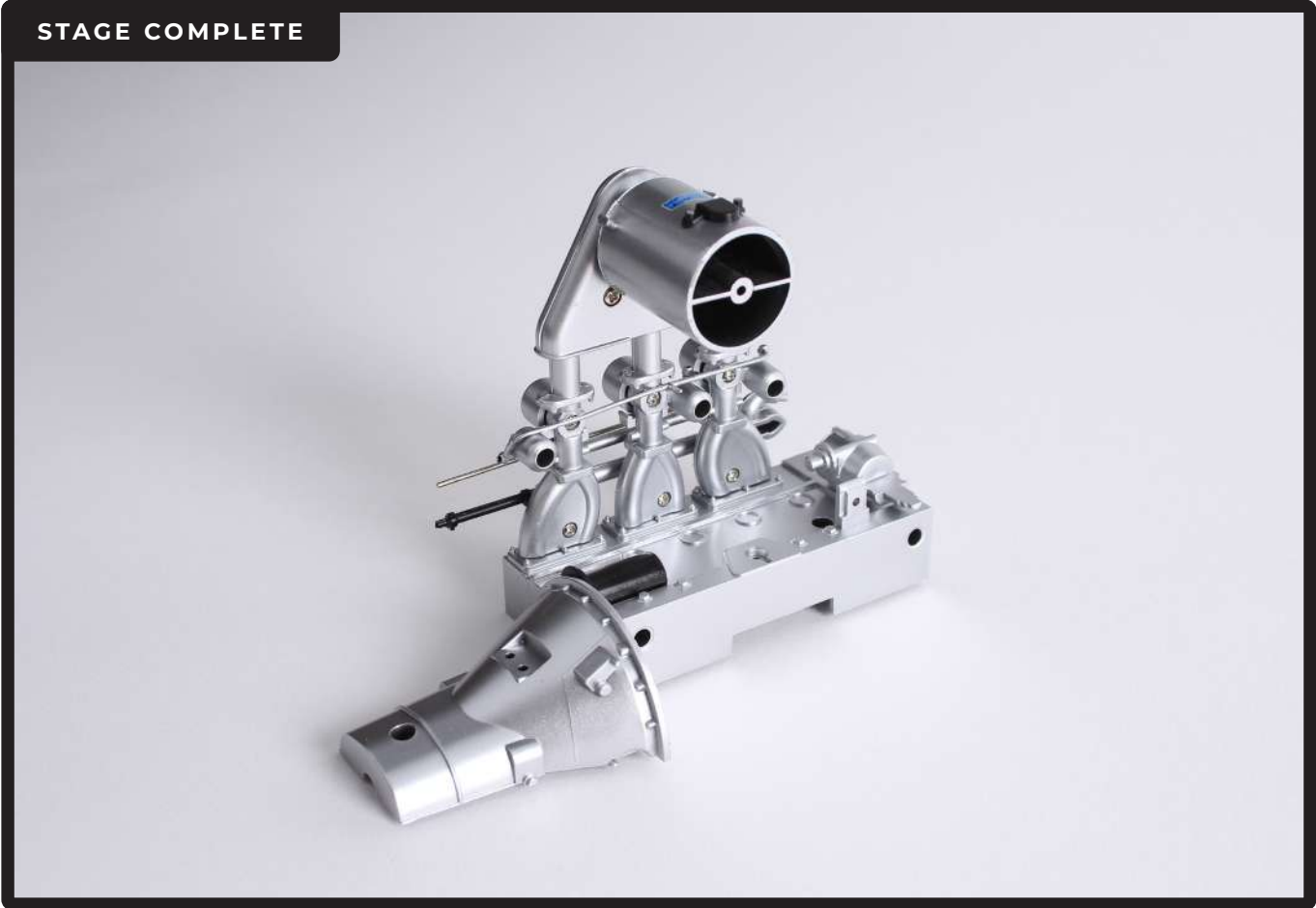

Stage 05: Assembling the Engine Block 2

You'll now assemble the other side of the engine block and fit the battery box to run the model's electrics.



STAGE 05 PARTS LIST

Name
Battery box
Filter head and hose
Engine block and clutch housing (left)
Screws type AG03 x 3

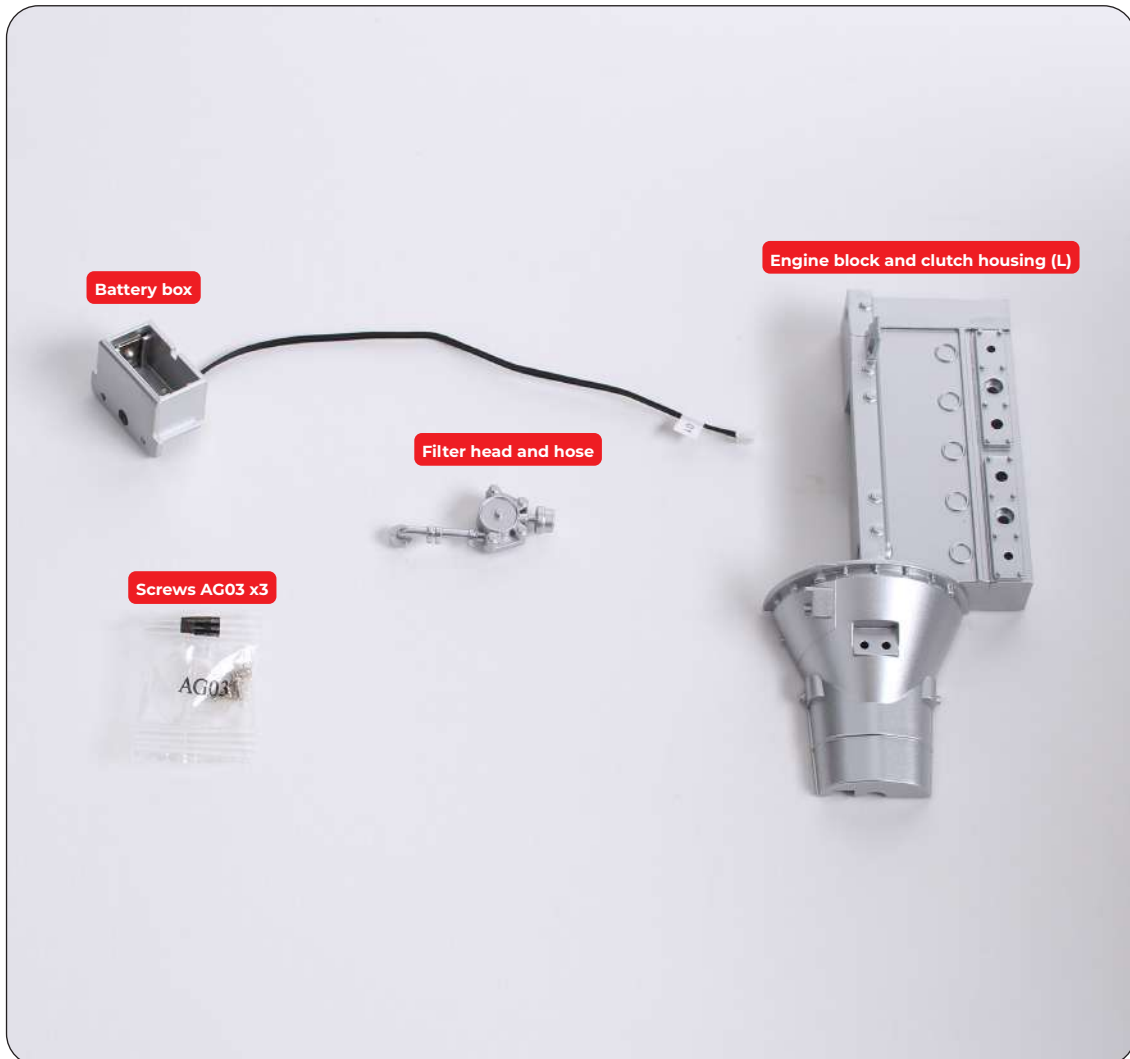

Stage 05: Assembling the Engine Block 2

STEP 1

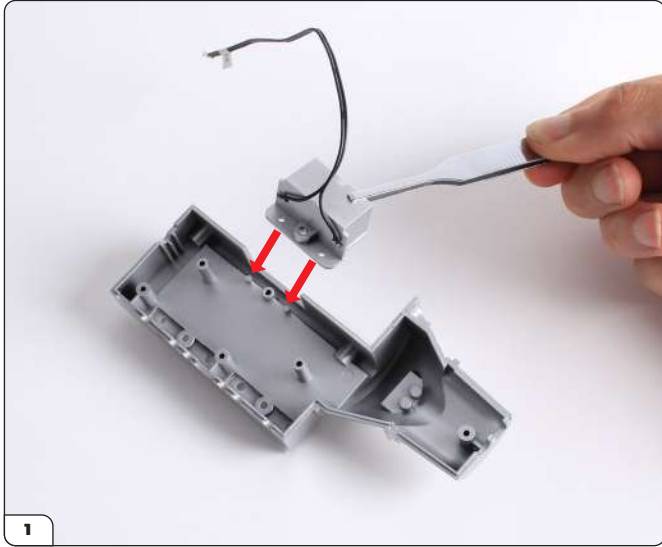

FIT THE BATTERY BOX TO THE ENGINE BLOCK

Align the small holes on the battery box with the two corresponding pins on the left side of the engine block supplied with this stage.



Press firmly to fit.

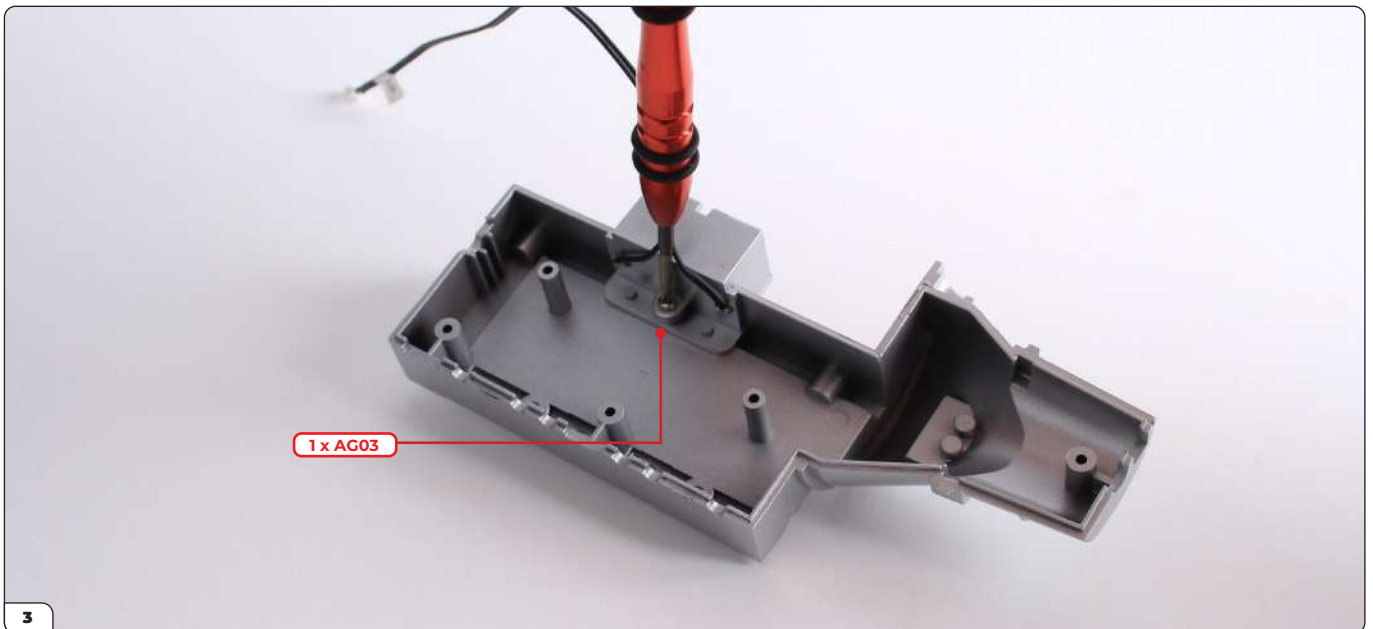

Secure the battery box in place using a type AG03 screw. When the model is completed, you will need to fit 3 x LR44 batteries to power the car's lights and sounds.

Stage 05: Assembling the Engine Block 2

STEP 2

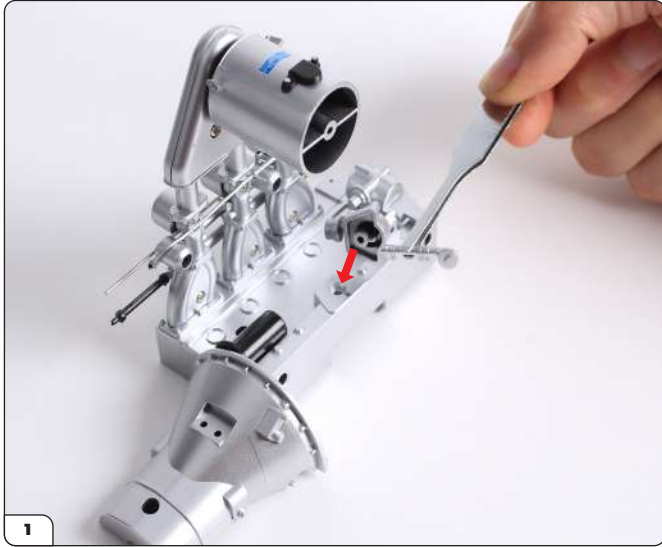

FIT THE FILTER HEAD AND HOSE TO THE ENGINE BLOCK ASSEMBLY FROM STAGE 04.

Align the keyhole-shaped lug on the filter head with the matching hole on the engine block.



Press the filter head into position, allowing the pipe to project outwards from the block.



Secure from the reverse side using an AG03 screw.

Stage 05: Assembling the Engine Block 2

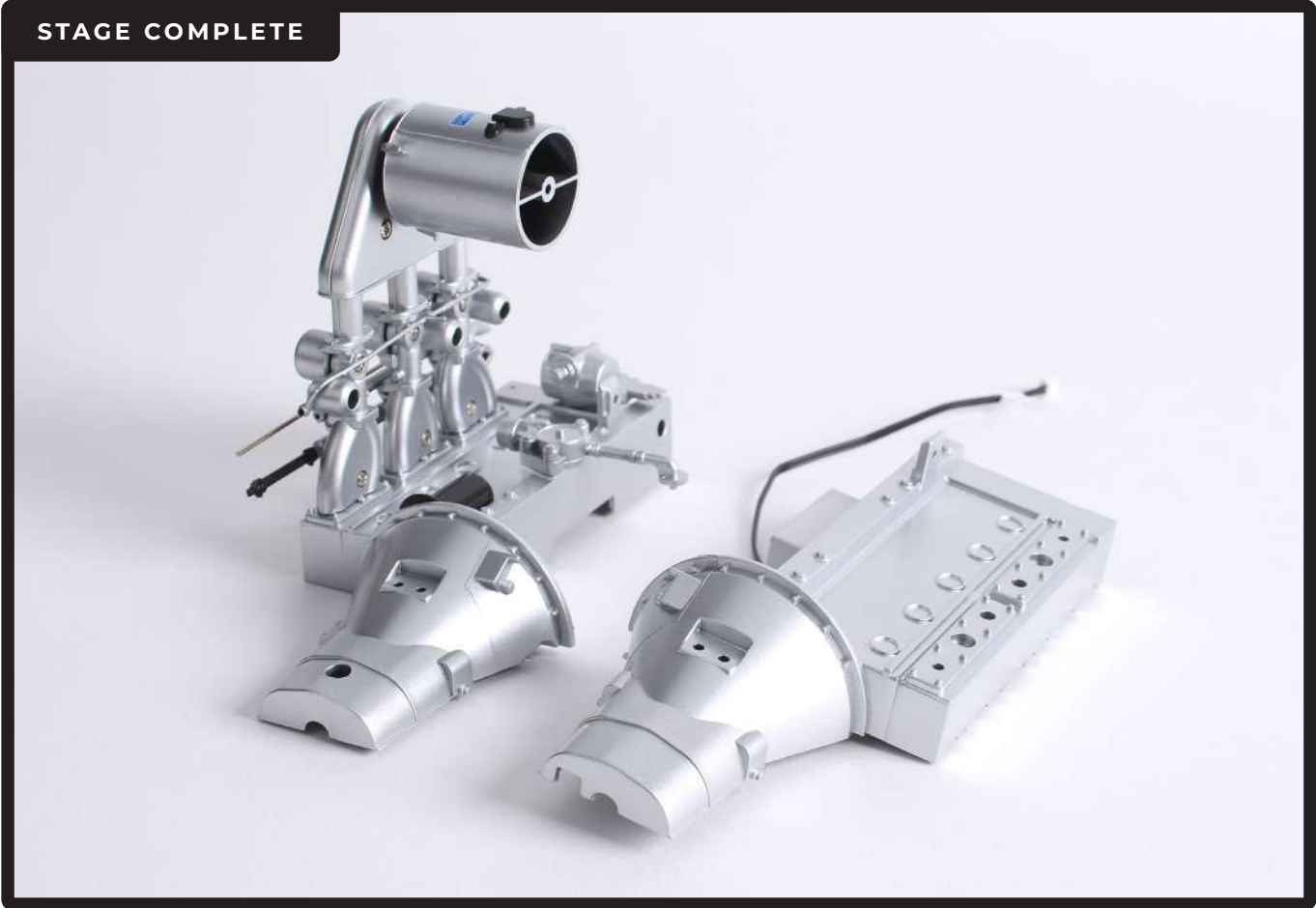

Stage 06: Assembling the Fan Belt and Electrics

In the next stage you will assemble the fan belt and its associated pulleys, plus the dynamo and other components of the electrical system.



STAGE 06 PARTS LIST

Name
Large Pulley
Fan belt and pulleys
Timing chain cover
Engine breather
Ignition coil (top)
Dynamo end cap
Ignition coil (bottom)
Dynamo
Ignition lead
Screws type AG05 x2
Screws type AG03 x4
Screws type AG02 x4



Stage 06: Assembling the Fan Belt and Electrics

STEP 1

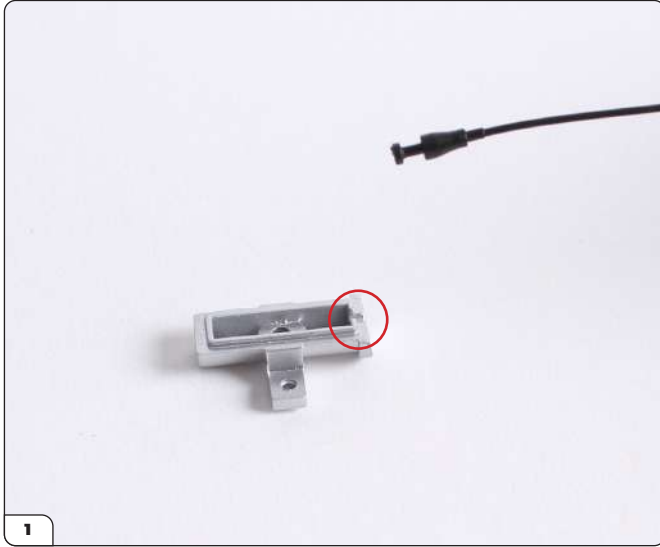

ASSEMBLE THE IGNITION COIL BEFORE FIXING IT TO THE CYLINDER HEAD, ALONG WITH THE ENGINE BREATHER.

Take the ignition coil (top) and note the notch on one side (circled). Then take the ignition lead and find the thicker end.

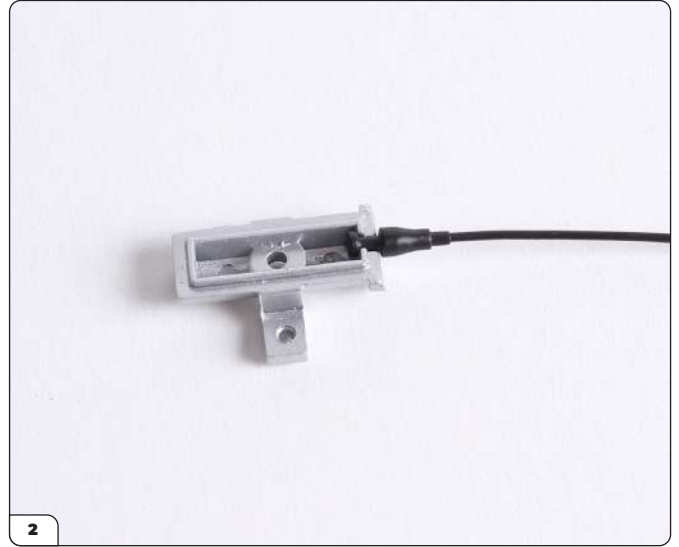

Rest the thicker end of the ignition lead in the notch on the ignition coil as shown.

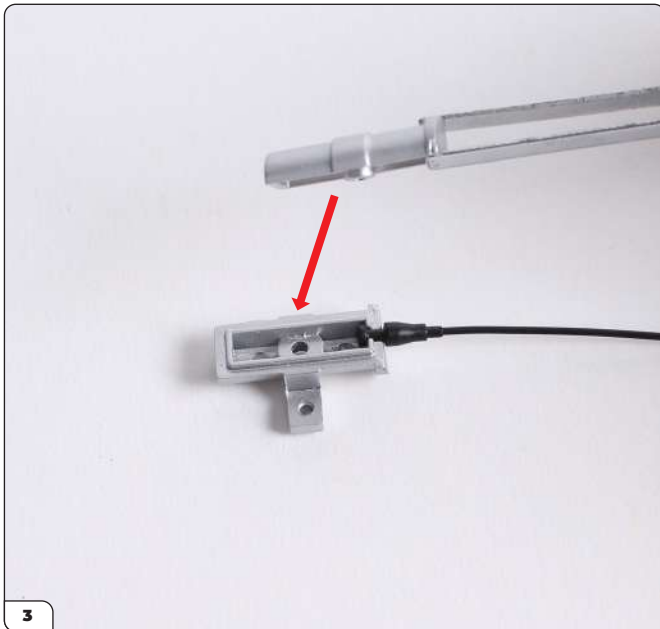

Place the ignition coil (bottom) on top to secure the lead into place.



Stage 06: Assembling the Fan Belt and Electrics



Secure the two halves of the coil together using an AG02 screw.



Align the mounting bracket on the side of the coil with the bracket on the end of the cylinder head from stage 01.



Fix in place using an AG02 screw.

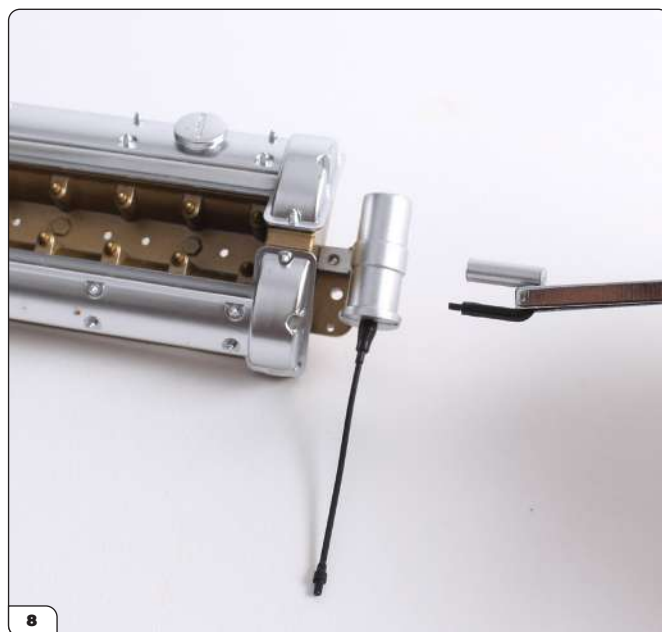

Use tweezers to fit the engine breather into the other two holes on the bracket.

Stage 06: Assembling the Fan Belt and Electrics

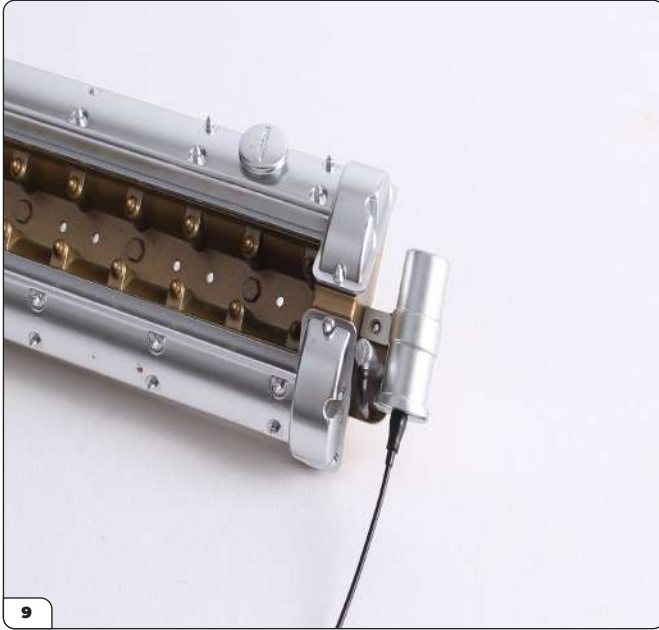

This shows the engine breather correctly fitted.

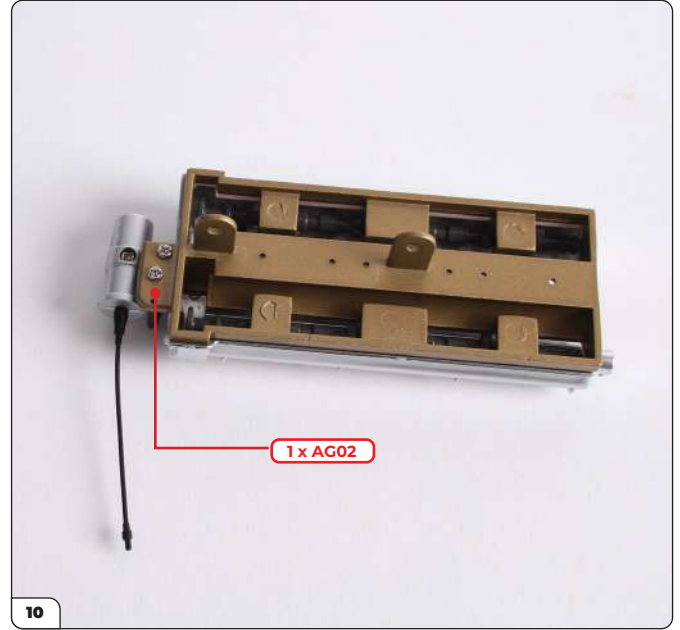

Secure in place from the reverse side using an AG02 screw.

STEP 2



ASSEMBLE THE FAN BELT AND PULLEYS

Align the lugs on the pulleys with the holes on the timing chain cover as shown.



Fit the parts together.

Stage 06: Assembling the Fan Belt and Electrics



Hold the assembly together and turn over to secure the pulleys in place using an AG03 screw.



Align the keyhole-shaped hole on the end of the dynamo with the matching lug on the timing chain cover.



Fit the dynamo to the cover.



Fit an AG03 screw through the body of the dynamo and tighten to secure the dynamo in place.

Stage 06: Assembling the Fan Belt and Electrics



Align the end cap over the end of the dynamo, noting the projecting tab to ensure it fits the correct the way round.



Press firmly into place.



Align the large pulley with the pulley on the fan belt.



Fit the large pulley between the fan belt and the cover, securing it in place with an AG03 screw. Fit an AG05 screw into the remaining hole in the timing chain cover.

Stage 06: Assembling the Fan Belt and Electrics

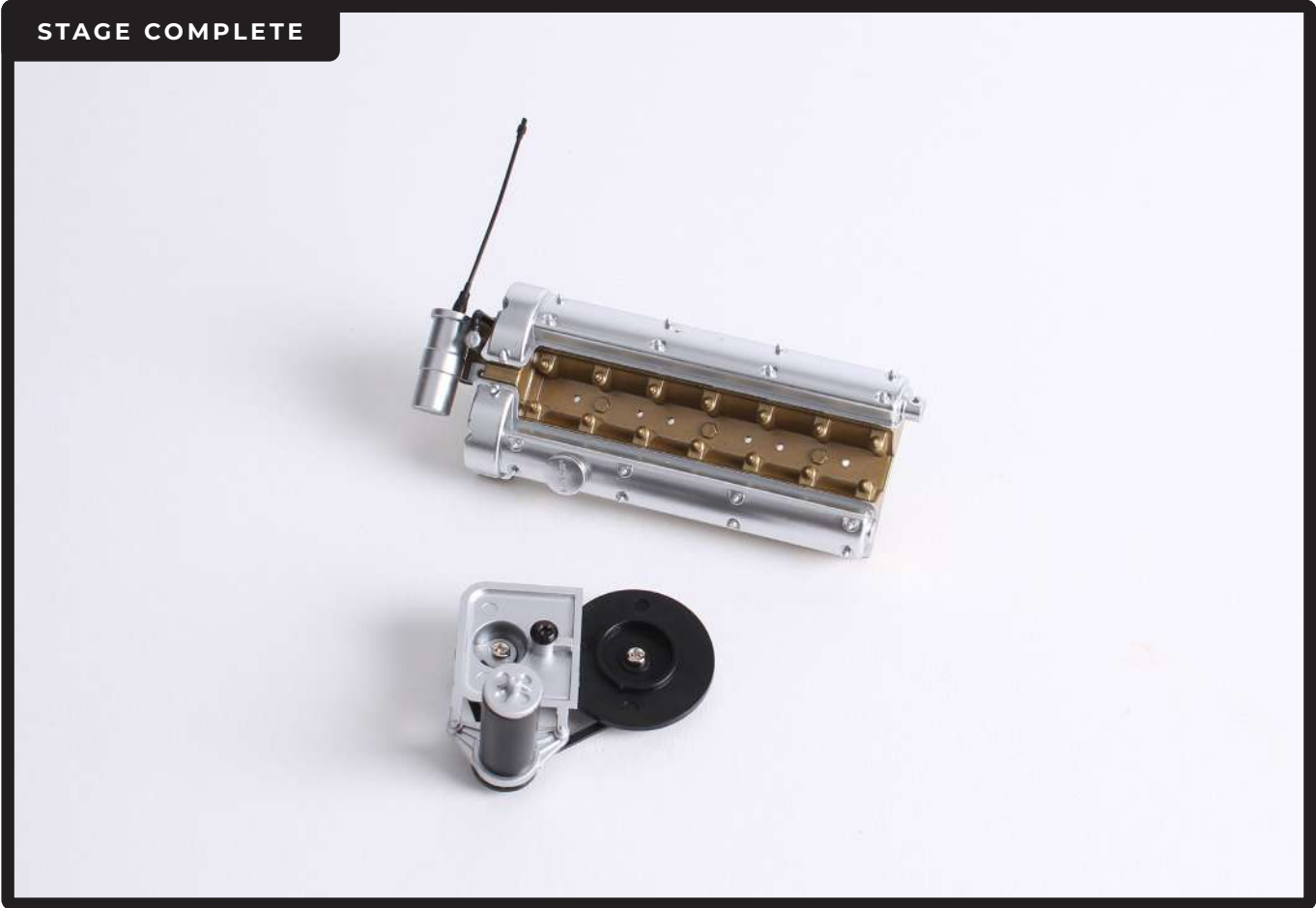

Stage 07: Assembling the Exhausts and Ignition

In this seventh stage you will finish assembling the engine, adding the exhaust manifolds to the engine block and plug leads to the top of the cylinder head.



STAGE 07 PARTS LIST

Name
Plug leads
Forward exhaust manifold
Rear exhaust manifold
Rev counter generator connector
Screws type AG03 x8

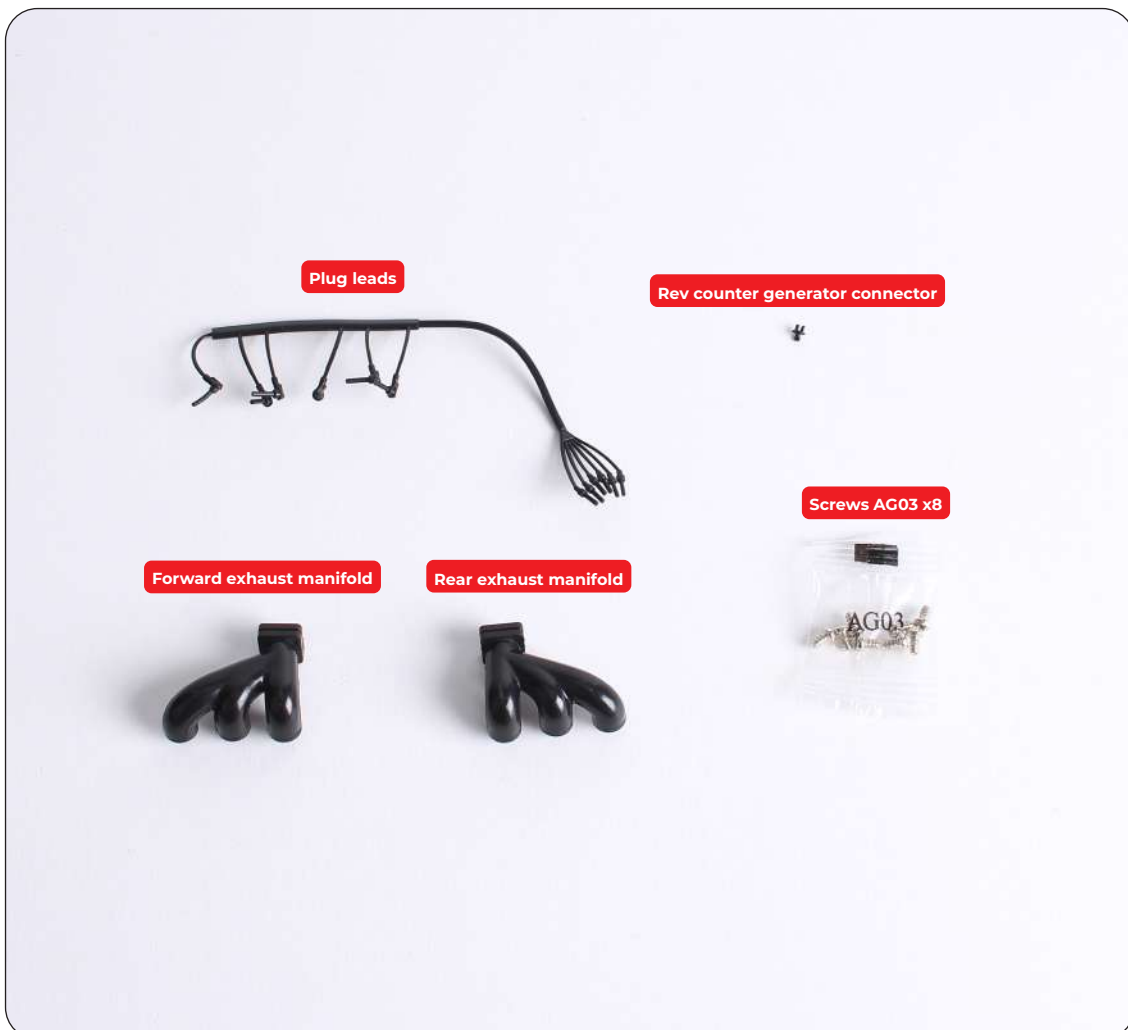

Stage 07: Assembling the Exhausts and Ignition

STEP 1

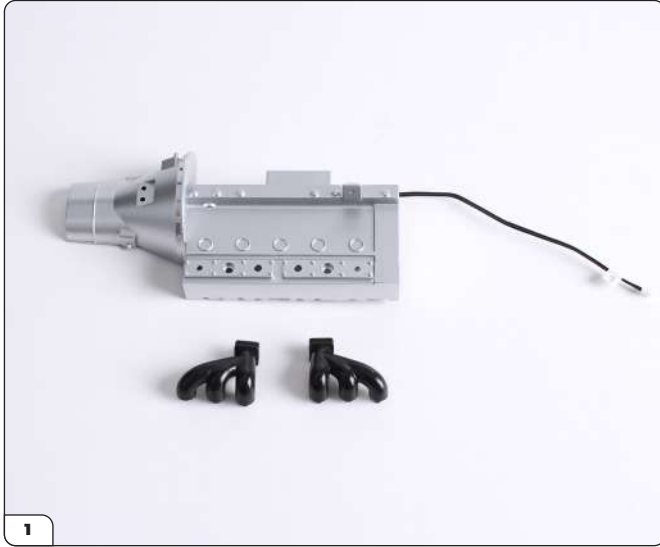

ATTACH THE EXHAUST MANIFOLDS TO THE ENGINE BLOCK

Take the engine block (L) that you last worked on in stage 05.

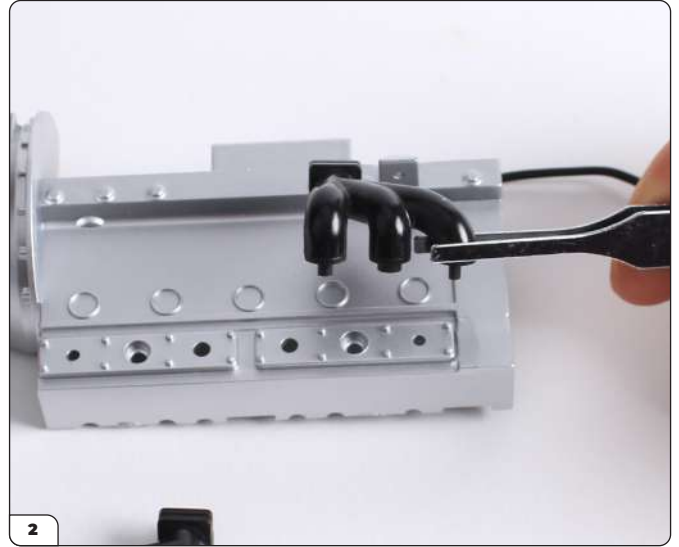

Align the three lugs on the forward exhaust manifold with the three holes on the block.



Press firmly into place.

Stage 07: Assembling the Exhausts and Ignition

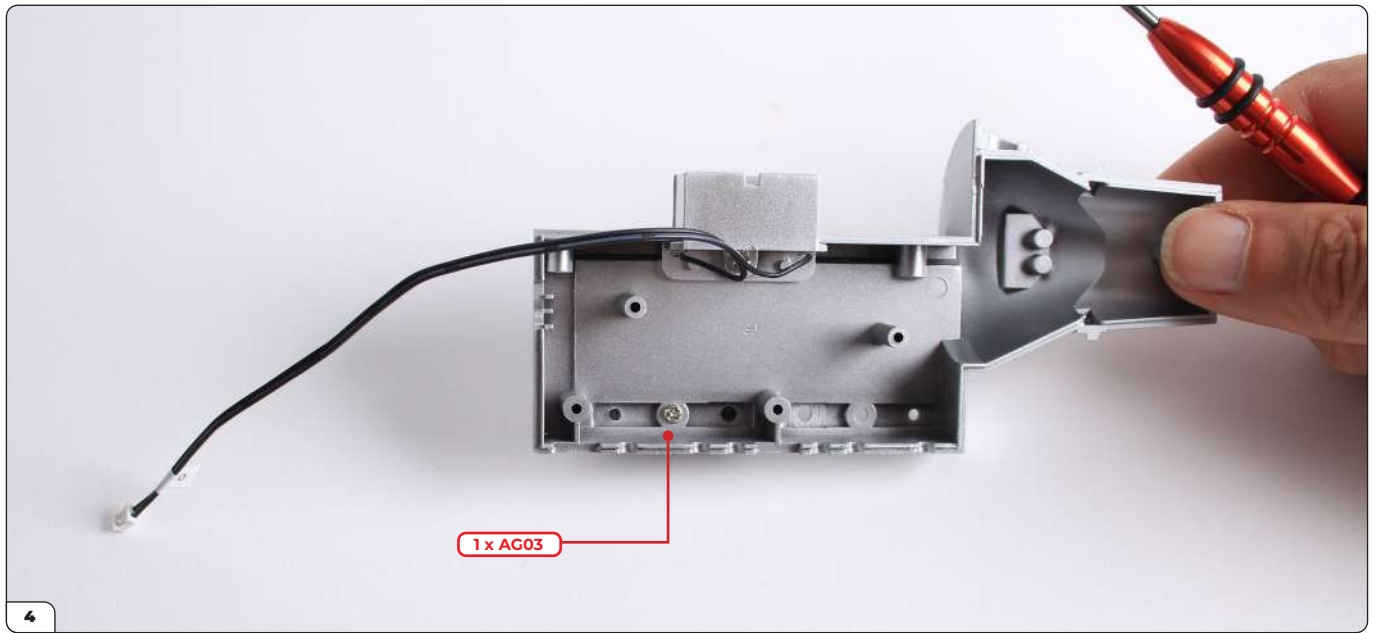

Secure from the reverse side using an AG03 screw.



Position the rear exhaust manifold in the remaining three holes and push firmly to fit.

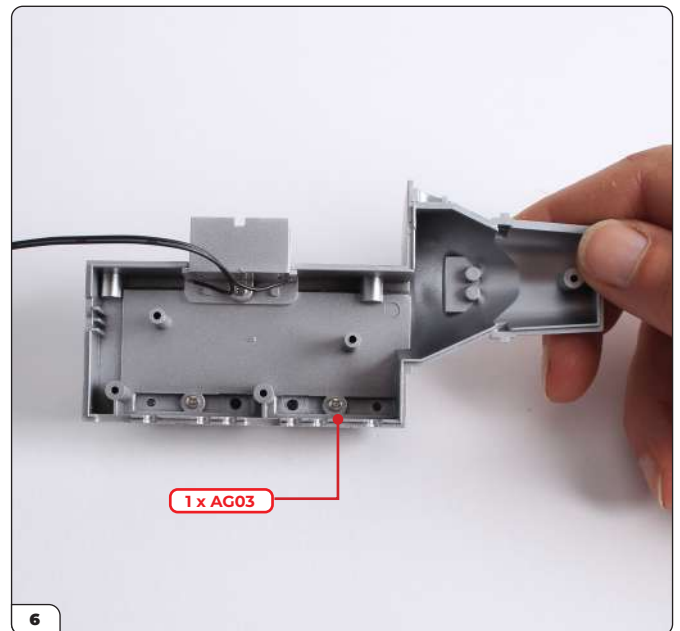

Secure from the underside using another AG03 screw.

Stage 07: Assembling the Exhausts and Ignition

STEP 2

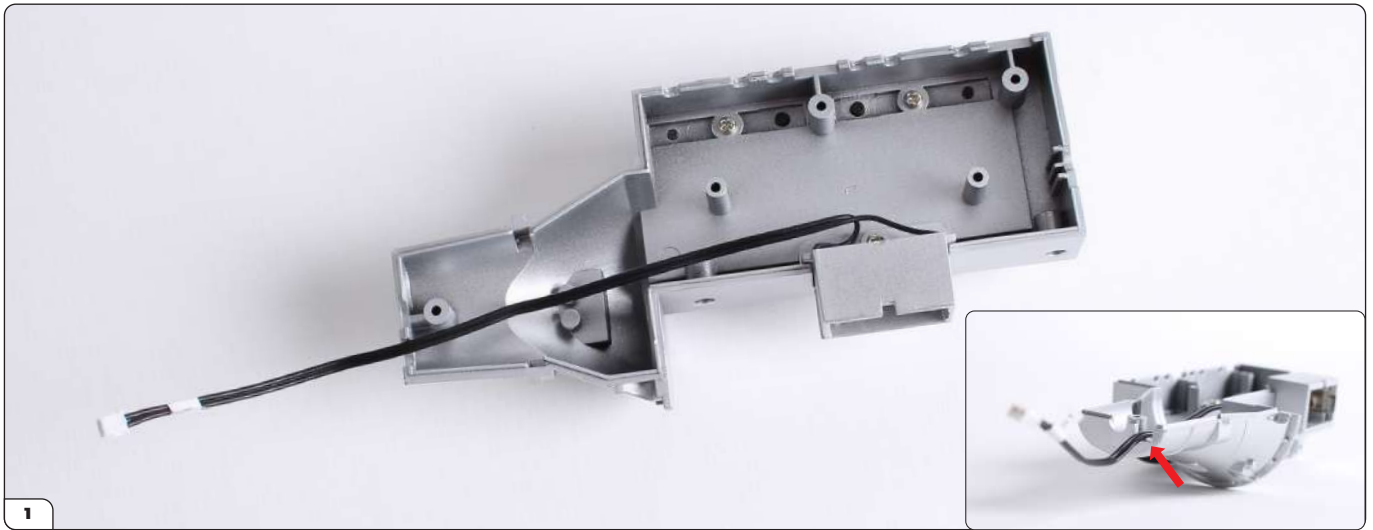

FIT THE CYLINDER HEAD ASSEMBLY TO THE ENGINE BLOCK

Start by locating the lead from the battery box within the 'U'- shaped notch on the engine block as shown (inset).

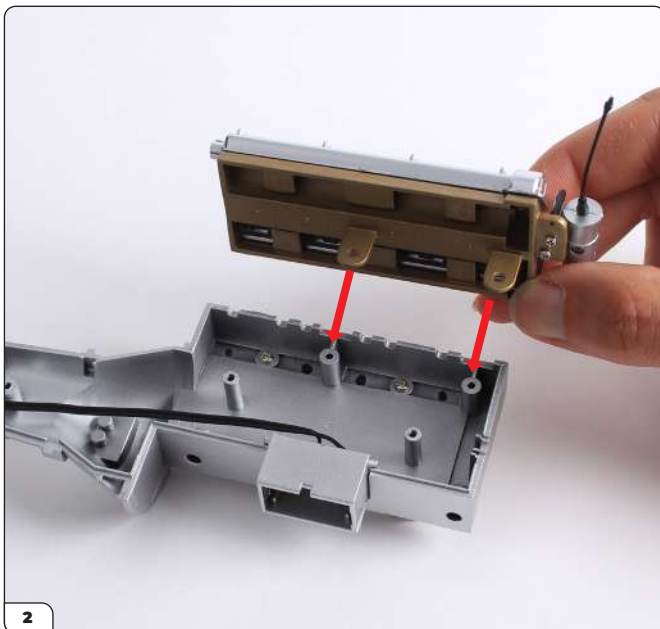

Align the two fixing tabs on the cylinder head assembly with the corresponding holes on the left-hand engine block.

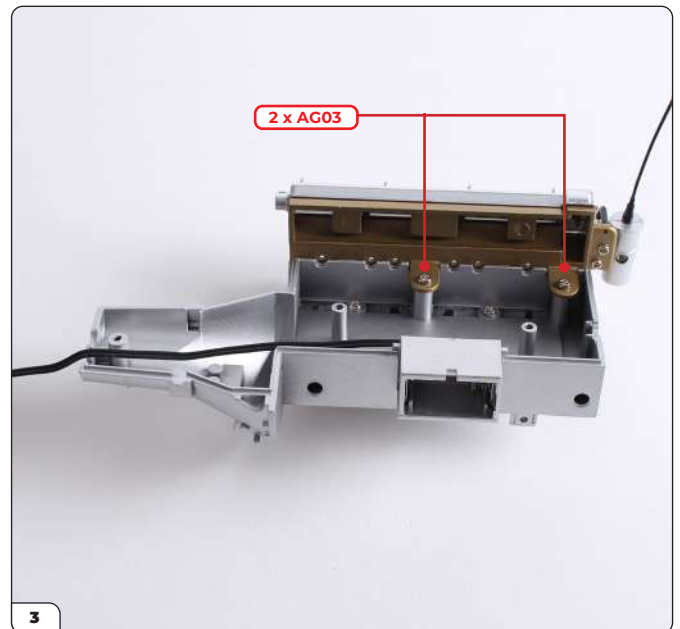

Fix the cylinder head in place using 2 x AG03 screws.

Stage 07: Assembling the Exhausts and Ignition

STEP 3

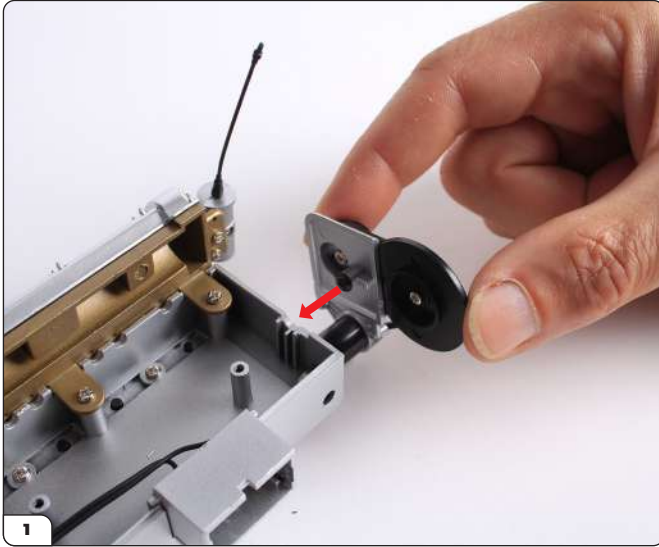

ATTACH THE PULLEY ASSEMBLY TO THE ENGINE BLOCK

Align the black screw in the post on the pulley with the notch on the engine block.

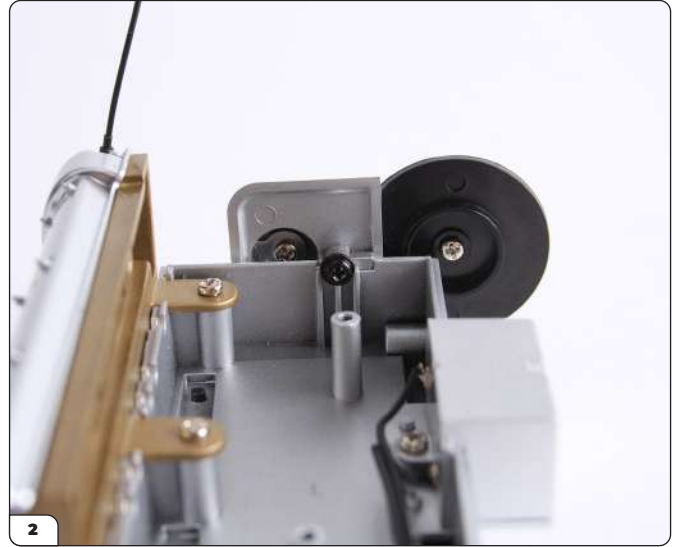

Slot the post into the notch.

STEP 4

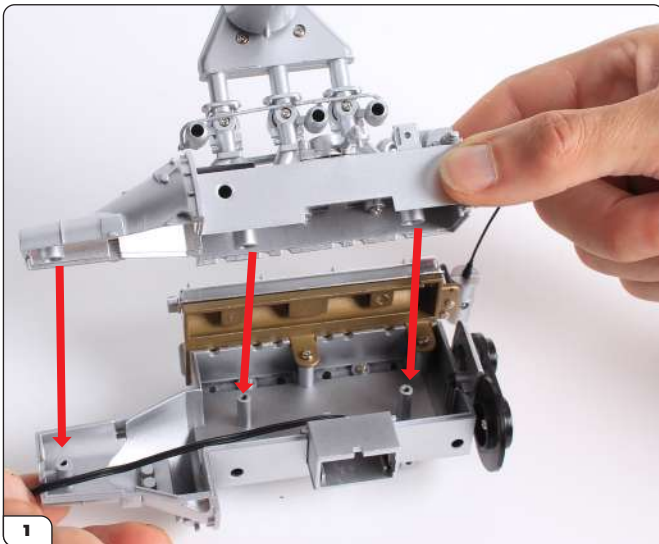

ATTACH THE TWO SIDES OF THE ENGINE BLOCK

With the pulley resting in place, align the two sides of the engine block. Check that the wire from the battery box remains correctly positioned within its notch and is not trapped.

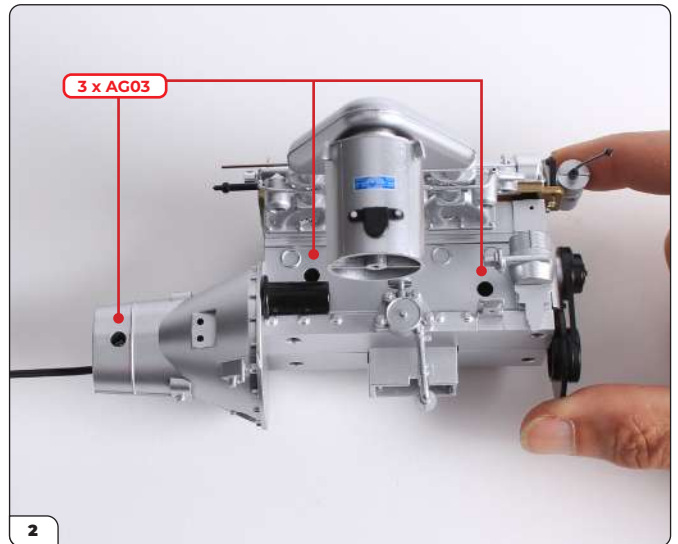

Fit the two sides together and secure them in place using 3 x AG03 screws.

Stage 07: Assembling the Exhausts and Ignition

STEP 5

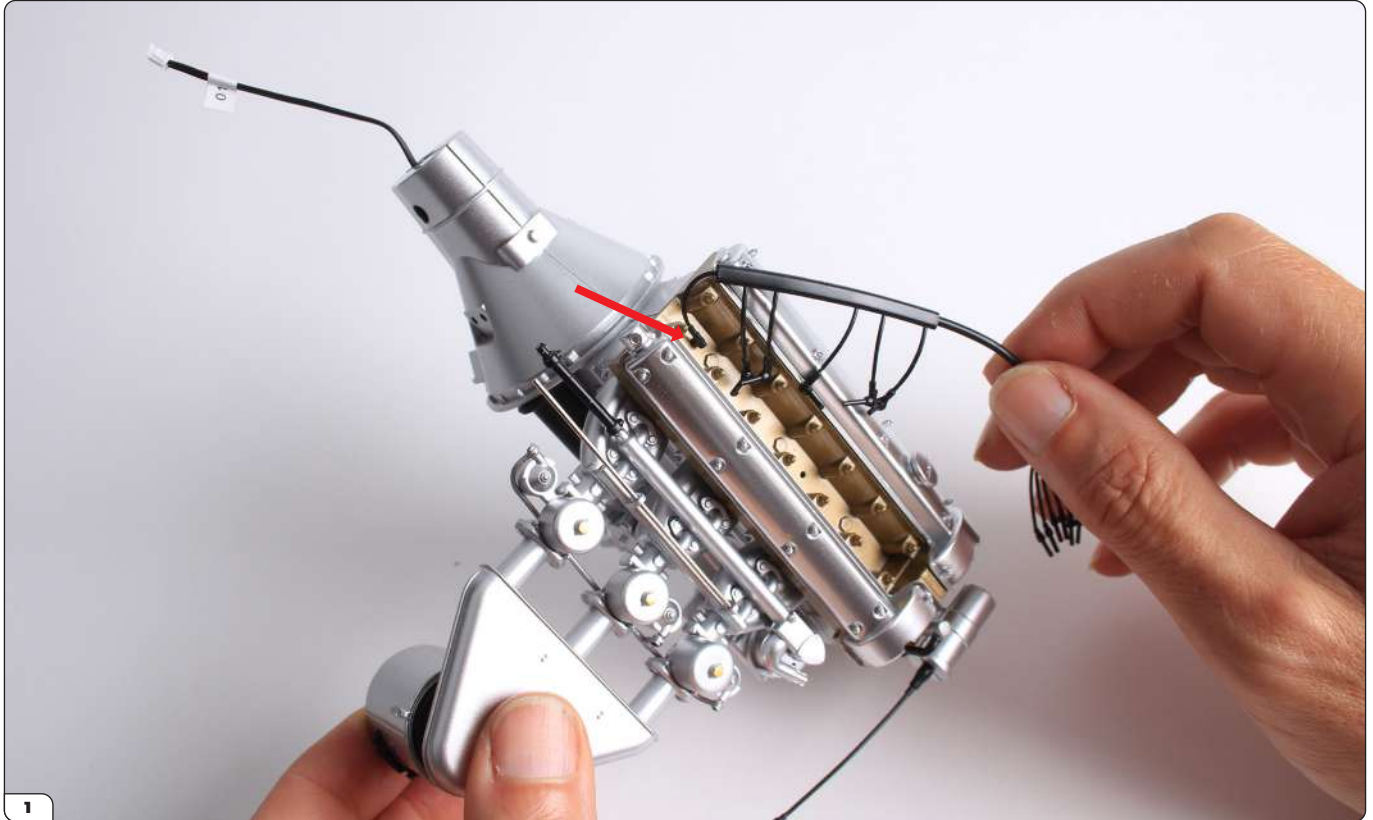

ATTACH THE IGNITION LEAD AND PLUG LEADS

Align the plug leads with the cylinder head, ensuring that the cluster of six connectors on the end are in the orientation shown. Using tweezers, push the first plug into the first hole as indicated by the arrow above.



Repeat to attach the next five plugs into the remaining five holes. along the cylinder head

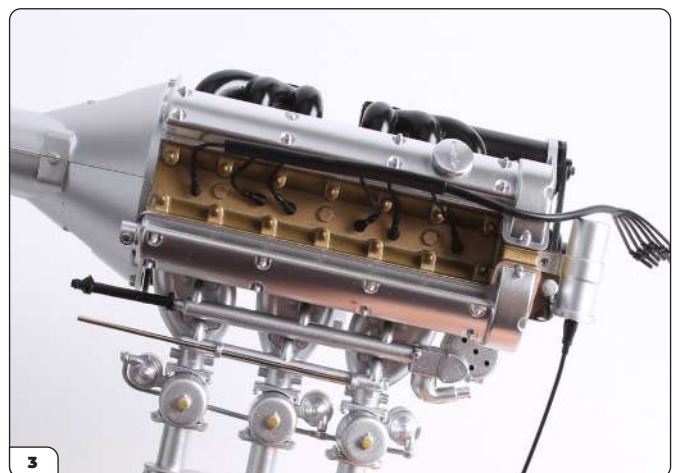

This shows the six plug leads fitted to the cylinder block with the cluster of connectors still loose at the end.

Stage 07: Assembling the Exhausts and Ignition

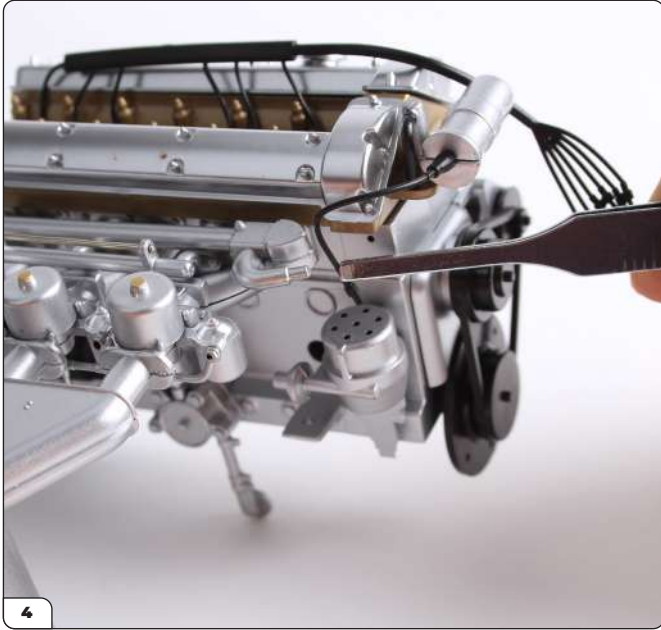

Using tweezers, grab the end of the ignition lead from the coil.

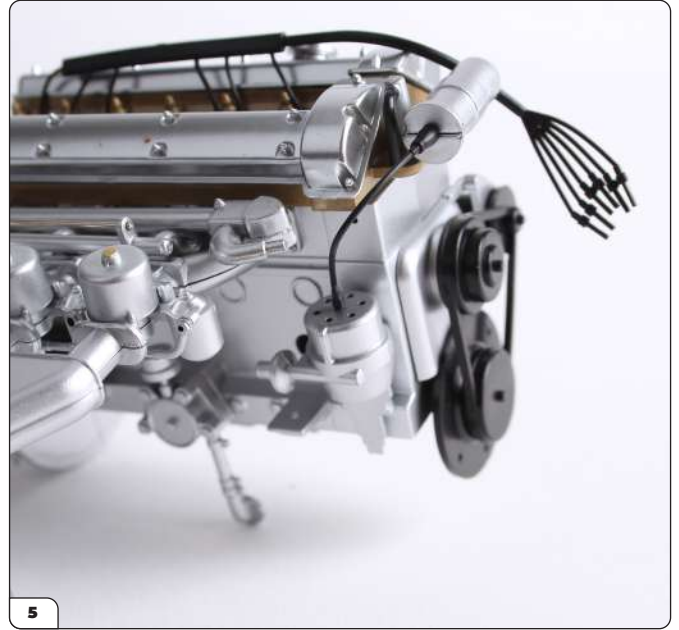

Push the ignition lead into the central hole in the distributor.

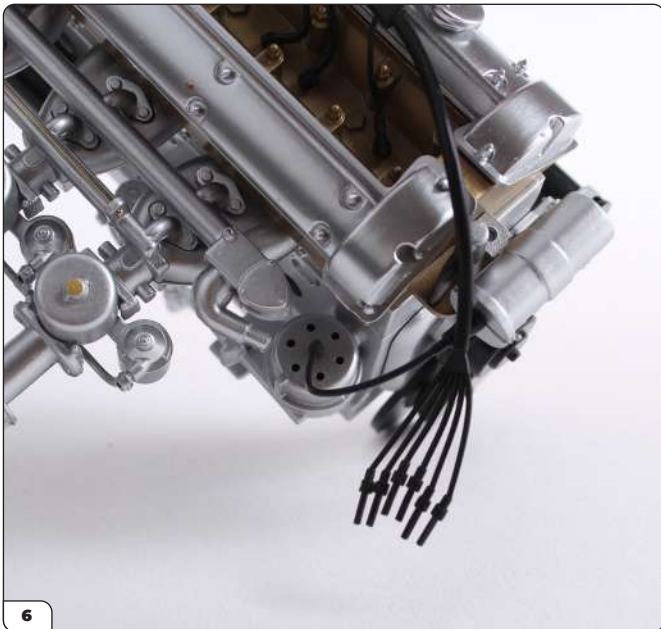

Now take the cluster of connectors and, starting with the innermost one, plug them into the holes on the distributor.



Fit all six leads in the same way.

Stage 07: Assembling the Exhausts and Ignition

STEP 6



FIT THE REV COUNTER GENERATOR CONNECTOR TO THE EXHAUST CAM COVER

Using tweezers, align the rev counter generator connector with the hole on the end of the exhaust cam cover.

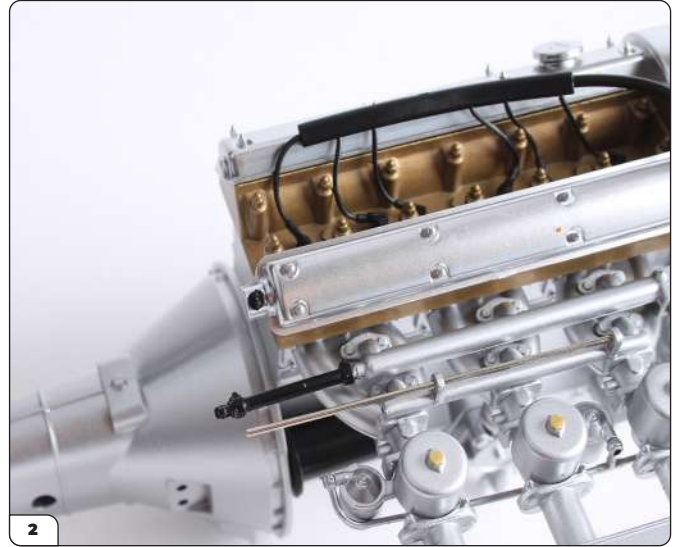

Push firmly, but carefully, to fit. If the fit is tight, try gently filing the connector with a modelling file. Take extra care here as this part is easily lost.

STAGE COMPLETE

