

OPTIMUS PRIME

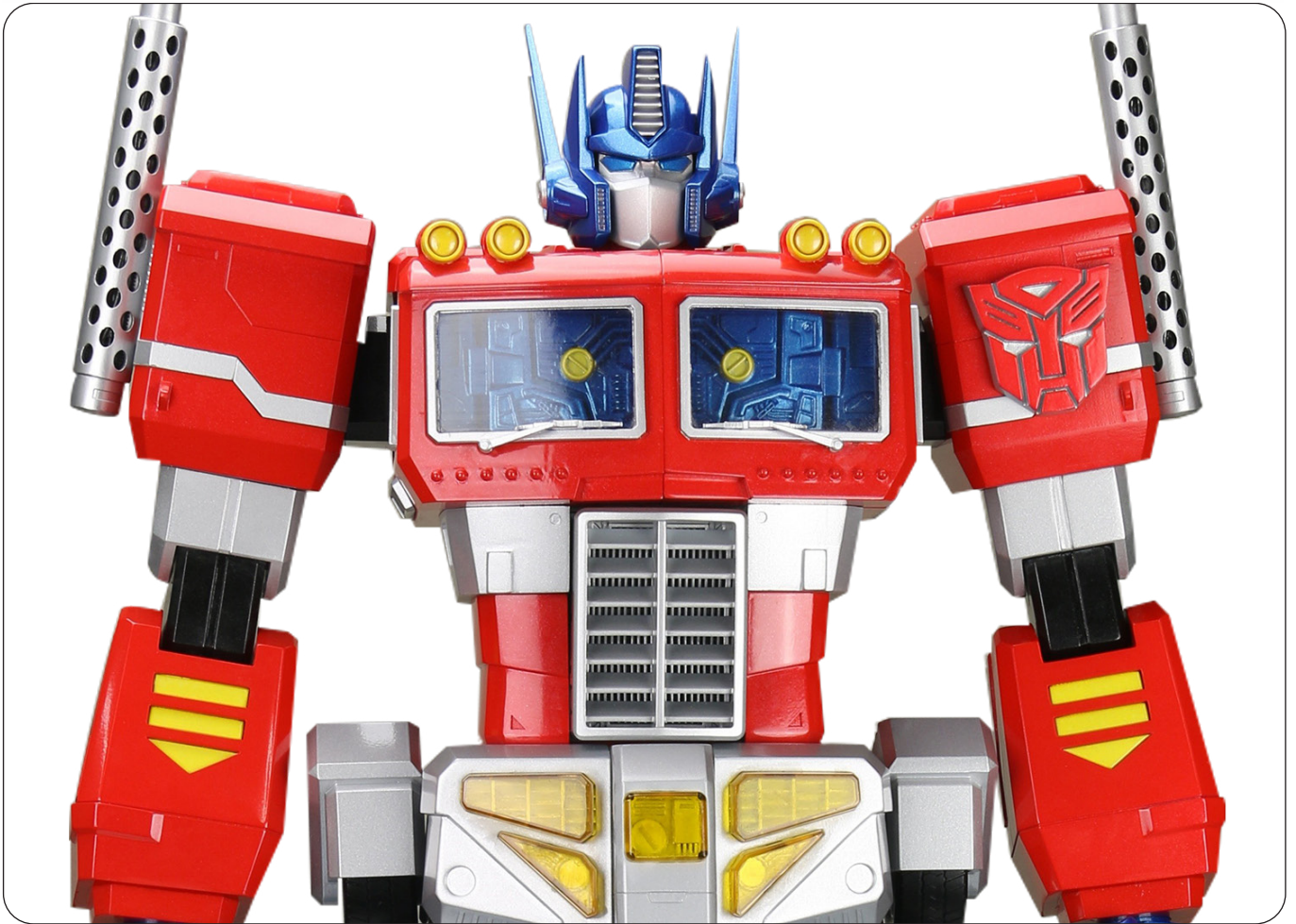

Pack 04

BUILD INSTRUCTIONS

ASSEMBLING THE RIGHT SHOULDER & ARM

AGORA
MODELS®

Advice from the experts

 **Please keep ALL unused screws as they may be required in a later stage.**

Please make sure you don't mix up the screws. They look quite similar, but the threads do vary slightly. Using the wrong screws may damage the parts.

When securing parts together using multiple screws, fit each screw loosely to ensure all the parts are correctly aligned before gently tightening them firmly, but not overtight, in the order in which you placed them.

The screwdriver can be magnetized by stroking it with a magnet (fridge magnet, etc.) enabling it to hold the screws and make assembly easier.

If a screw is tight going into a metal part, do not force it as you may shear the head off. Remove it and put a tiny smear of Vaseline, soap or light oil on the thread. That will lubricate it and make it easier to drive home.

Some parts will require a little glue for assembly. Please apply glue sparingly and use a cocktail stick so that you don't use too much nor apply the glue too heavily. We recommend superglue gel or Extra Thin Liquid modeling glue. Where possible, parts should be test-fitted in place before gluing.



Look out for the glue symbol and apply glue to the red area indicated in the picture.

During the course of this build, you will receive many pieces that you will assemble immediately – following the instructions in the corresponding stage – and other pieces that you should store in the tray supplied, for use in future assembly stages.

Always protect the paint finish on components by placing a cutting mat, sheet of white paper or soft cloth on your work surface.

Left and Right! When building your Optimus Prime, the left or right hand side refers to each side as viewed by Optimus Prime. Optimus Prime's left arm is on the viewer's right.



WARNING: Some parts are assembled using magnets. These magnets can cause serious injury if they are swallowed. Keep away from children. If you suspect a magnet has been swallowed, seek medical help straight away.

Pack 4 Parts

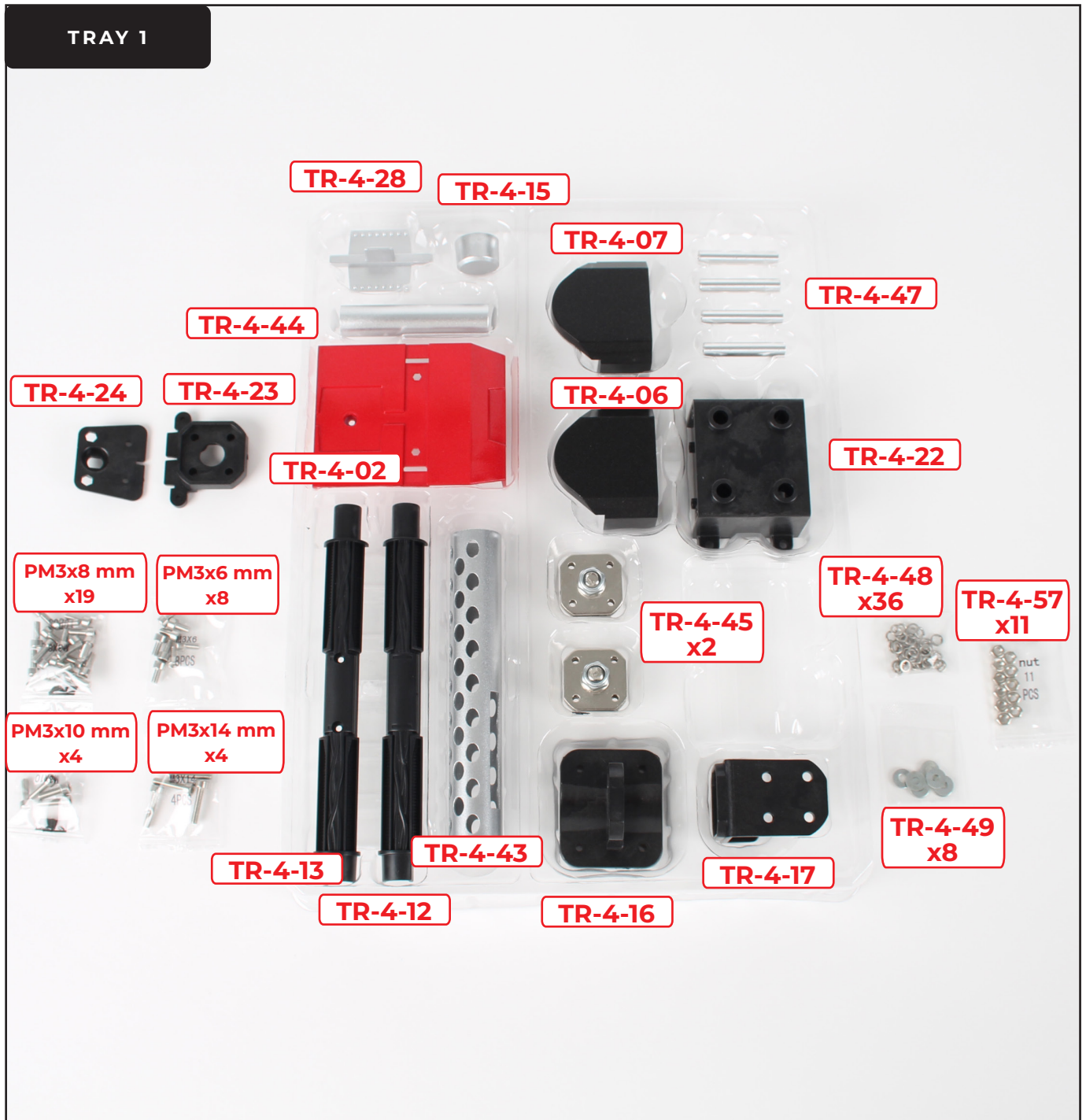

Pack 4 Parts

TRAY 2

TR-4-11



TR-4-10



TR-4-35

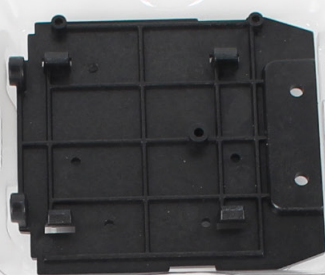

TR-4-34

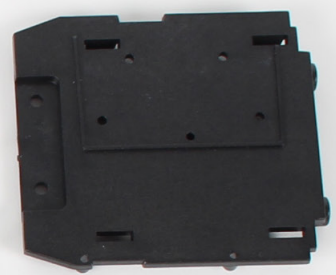

PWM2x6 mm
x5



PWM2x4 mm
x9

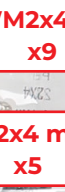

PWM2.3x6 mm
x31



PB2x4 mm
x5



TR-4-14



TR-4-26

TR-4-20

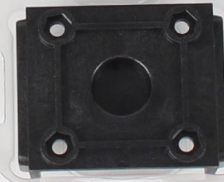

TR-4-25

TR-4-46
X2



TR-4-41



TR-4-18



TR-4-21

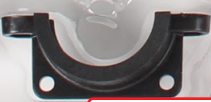

TR-4-04

TR-4-29



TR-4-19



TR-4-27



Pack 4 Parts

TRAY 3



Assembling the Right Shoulder & Arm

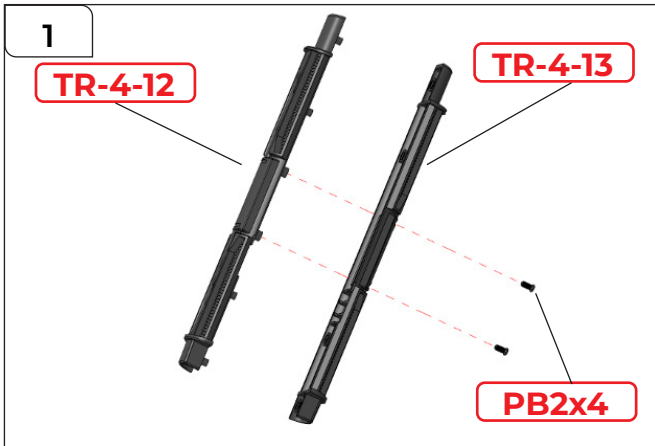

STEP 1

Align TR-4-12 and TR-4-13 as shown and secure them together using 2x PB2x4 mm screws.

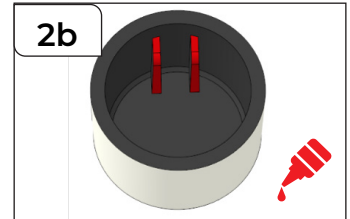

STEP 2

Glue the assembly from step 1 as shown in 2a, then fix TR-4-44 over the glued end as shown.

Glue TR-4-15 as shown in 2b, then fix it to the opposite end of the assembly, taking care to align the glued fixing points.

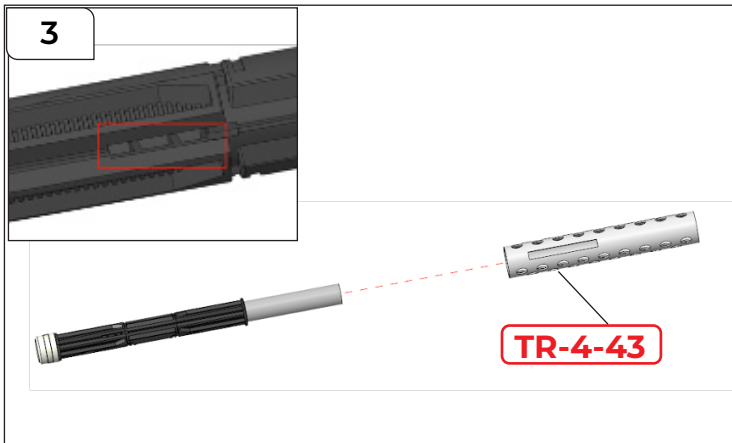

STEP 3

Push TR-4-43 onto the assembly from step 2, paying attention to the detail highlighted in the inset image. Check that the slot in TR-4-43 is oriented over the corresponding slot in the assembly.

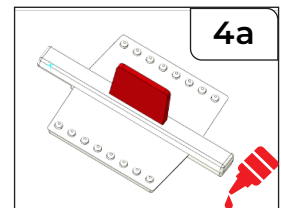

STEP 4

Apply a little glue to TR-4-28 as shown in 4a and fix to the assembly from step 3. Study the inset image (bottom, right) to check that part TR-4-28 is in the correct orientation. There is a step at one end.

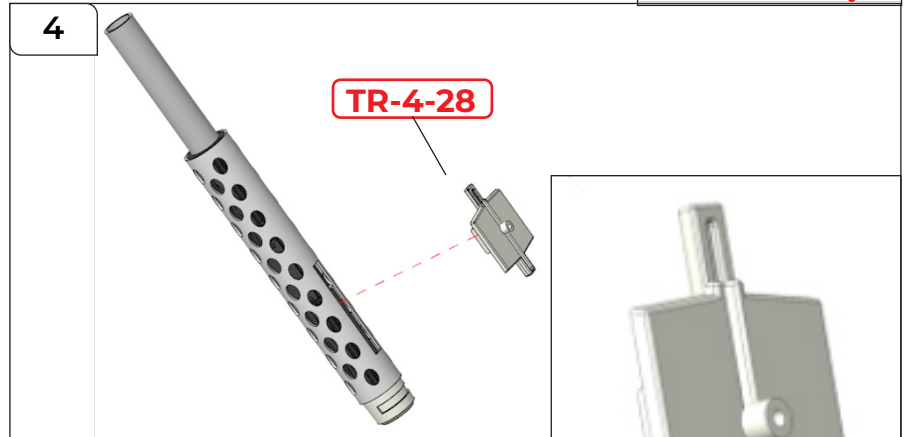

Assembling the Right Shoulder & Arm

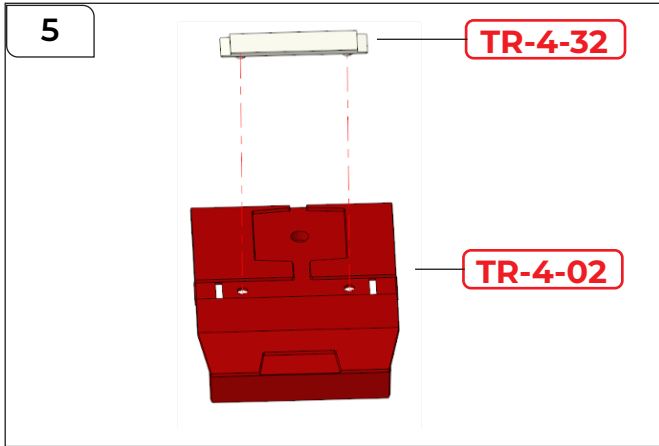

STEP 5

Attach TR-4-32 to TR-4-02.

STEP 6

Fix TR-4-02 to the assembly from step 4 using 1x PB2.3x6 mm screw.

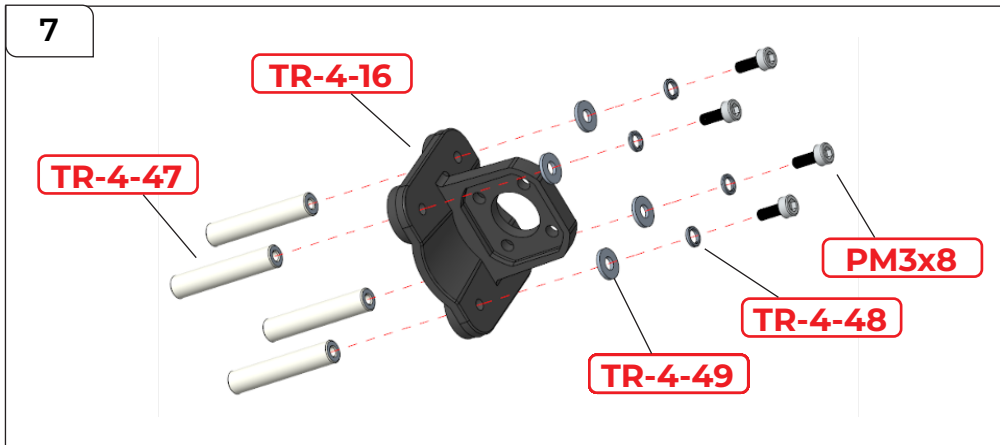
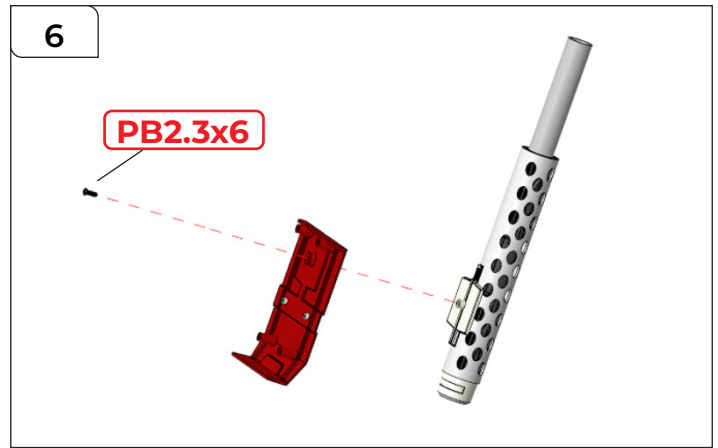

STEP 7

Thread TR-4-48 and TR-4-49 onto a PM3x8 mm screw before inserting the assembled screw through a corner screw hole in TR-4-16. Then attach TR-4-47. Repeat with the other 3 sets, driving them through the remaining 3 screw holes.

Fasten each screw quite tight.

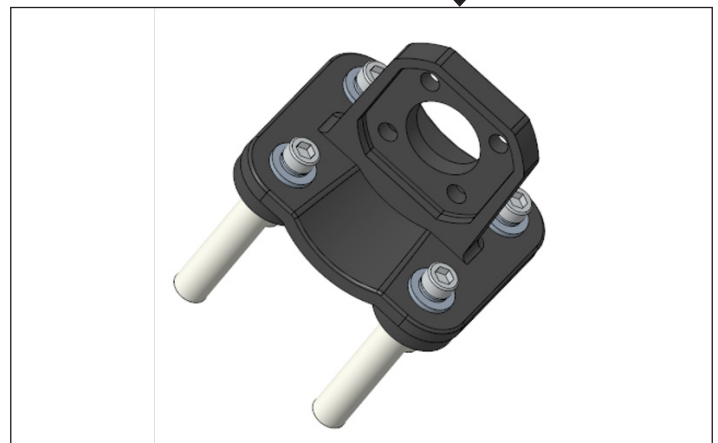

Assembling the Right Shoulder & Arm

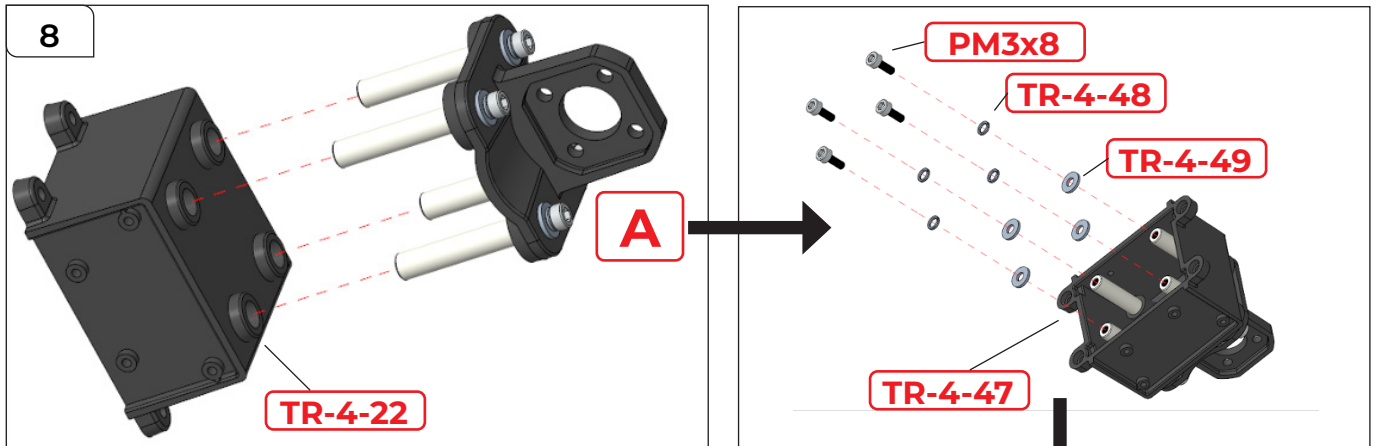

STEP 8

Push assembly A into TR-4-22 as shown.

Thread washers TR-4-48 and then TR-4-49 onto a PM3x8 mm screw. Make 4 sets and then screw them into TR-4-47 as shown.

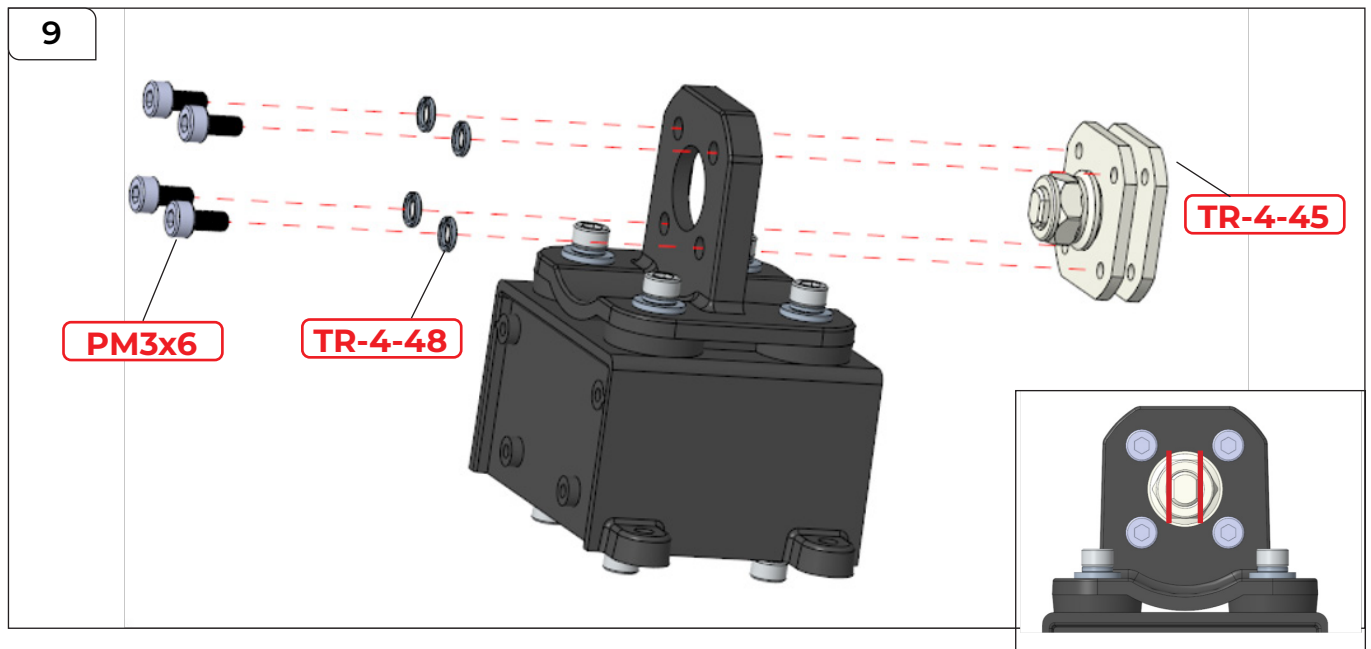
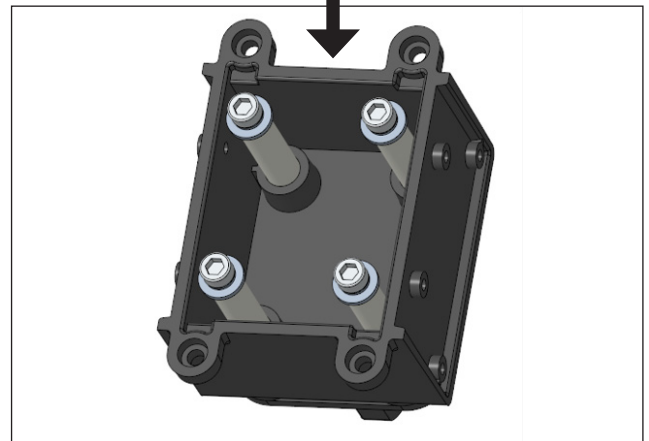

STEP 9

Push TR-4-45 through the hole in TR-4-47, paying close attention to the orientation. The top and bottom edges are rounded, the left and right edges are flat (see inset image and 9a-b on the next page). Thread TR-4-48 onto PM3x6 mm and make 4 sets, using them to secure TR-4-45 in place as shown.

Assembling the Right Shoulder & Arm

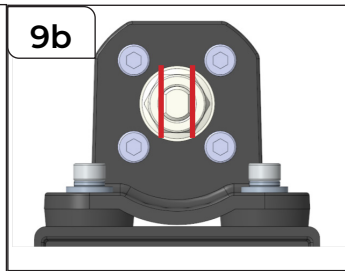
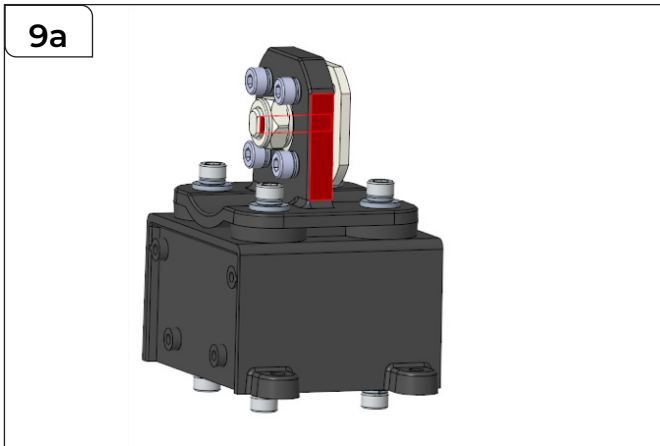

IMPORTANT! Check that the sides are flat, as indicated by the red lines.

STEP 10

Place a washer **TR-4-48** onto a **PM3x6** mm screw before pushing it through **TR-4-47** to attach it to **TR-4-45**. Repeat three more times, pushing the screw assemblies through the remaining 3 screw holes. There is no particular direction for parts at this stage.

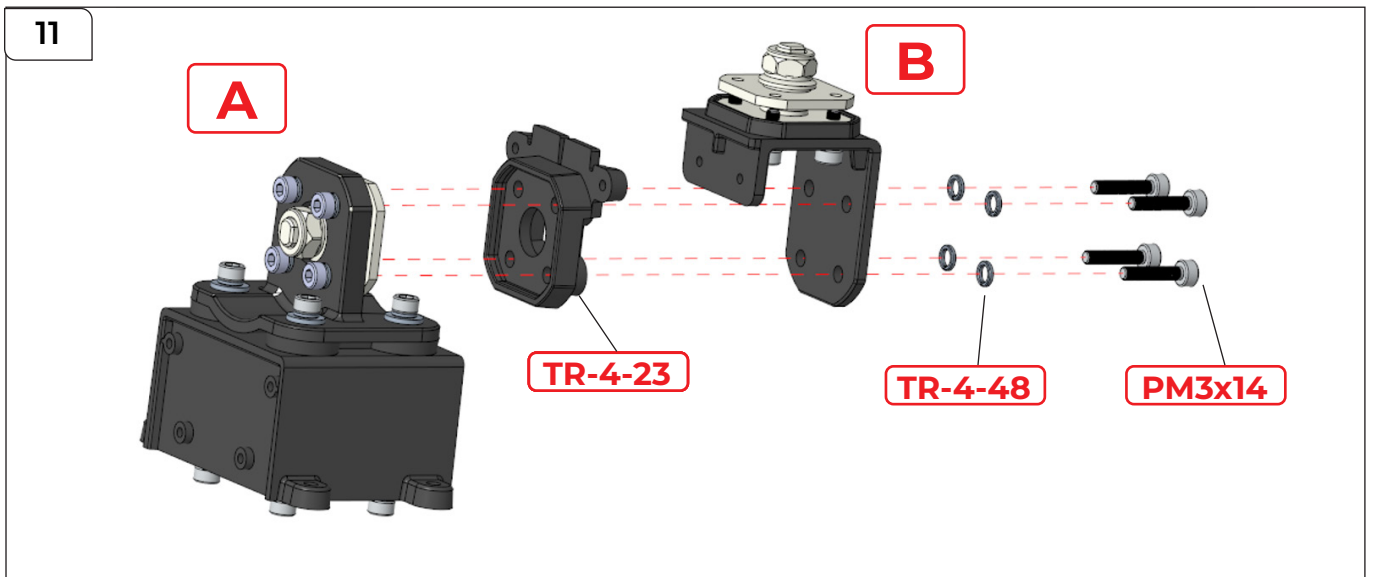
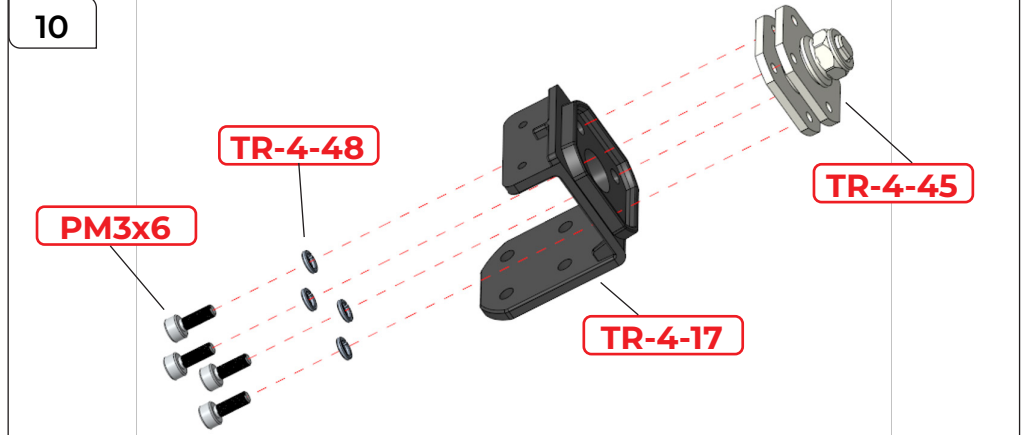

STEP 11

Align assembly A, **TR-4-2w3** and assembly B as shown. Push the parts together. Thread washers **TR-4-48** onto screws **PM3x14** mm and make 4 sets. Fix the parts together as shown, pushing each screw assembly through the four screw holes on each part.

Assembling the Right Shoulder & Arm

12

PB2.3x6

A

TR-4-24

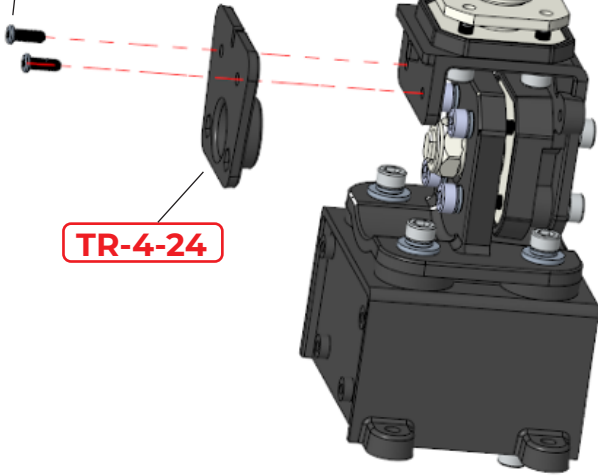

STEP 12

Align TR-4-24 with assembly A as shown, then fix it in place using **2x PB2.3x6 mm** screws. Pay close attention to the shape of the hole in part TR-4-24, checking that it fits the fixing point on TR-4-45 (shown in the completed 12b below).

12b

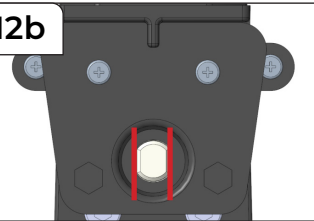

13

B

A

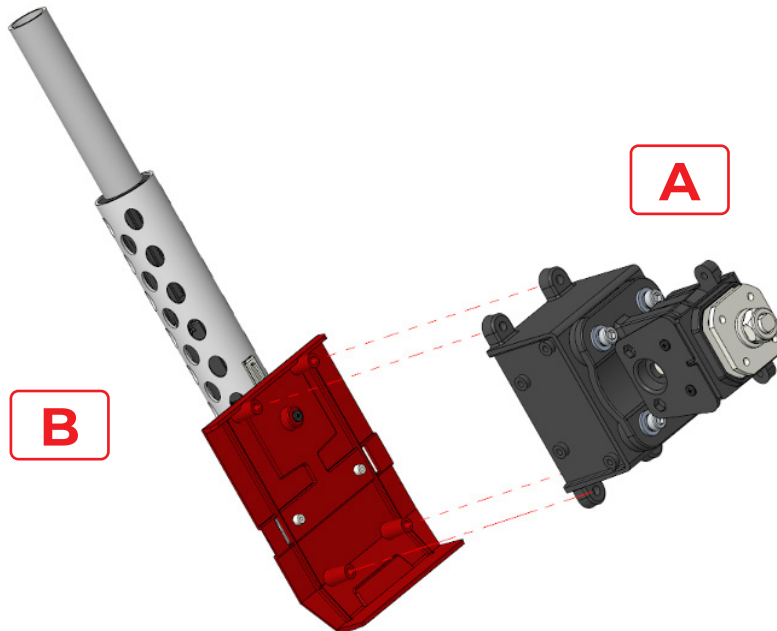

STEP 13

Attach assembly A to assembly B as shown.

Assembling the Right Shoulder & Arm

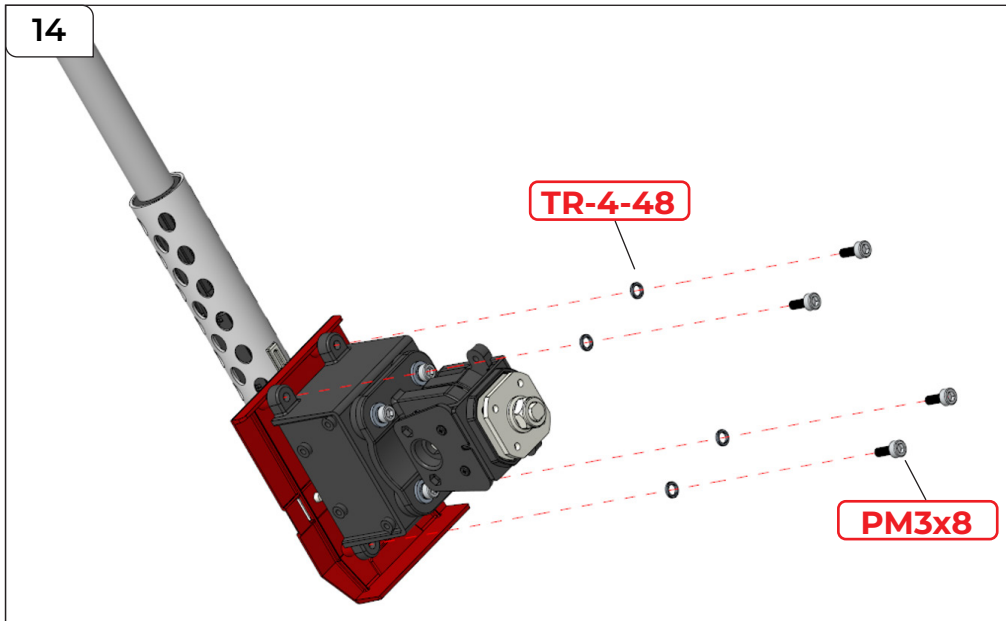

STEP 14

Secure A to B using 4x washers TR-4-48 and 4x PM3x8 mm screws as shown.

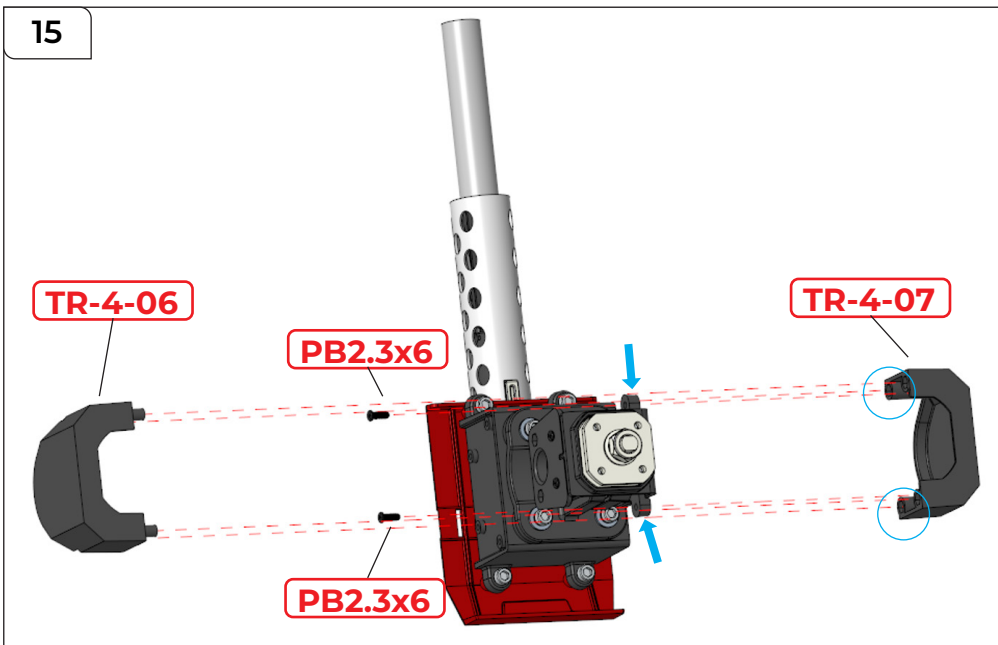

STEP 15

Attach TR-4-07 to assembly A by driving 2x PB2.3x6 mm screws through the tabs (blue arrows) and into the screw posts on TR-4-07 (blue circles). Push the lugs on TR-4-06 into TR-4-07.

Assembling the Right Shoulder & Arm

16

STEP 16

Secure TR-4-35 to A using 4x PB2.3x6 mm screws.

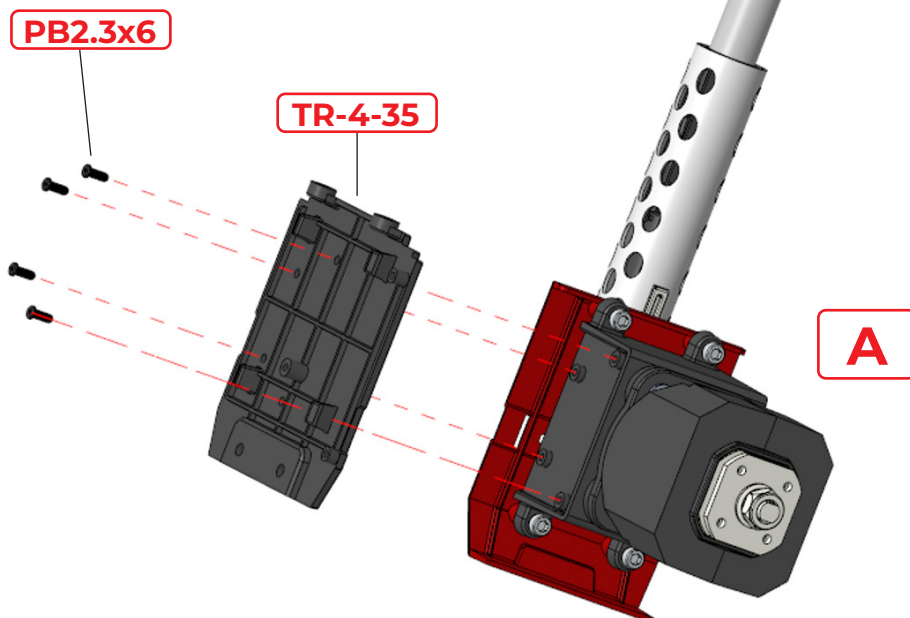

17

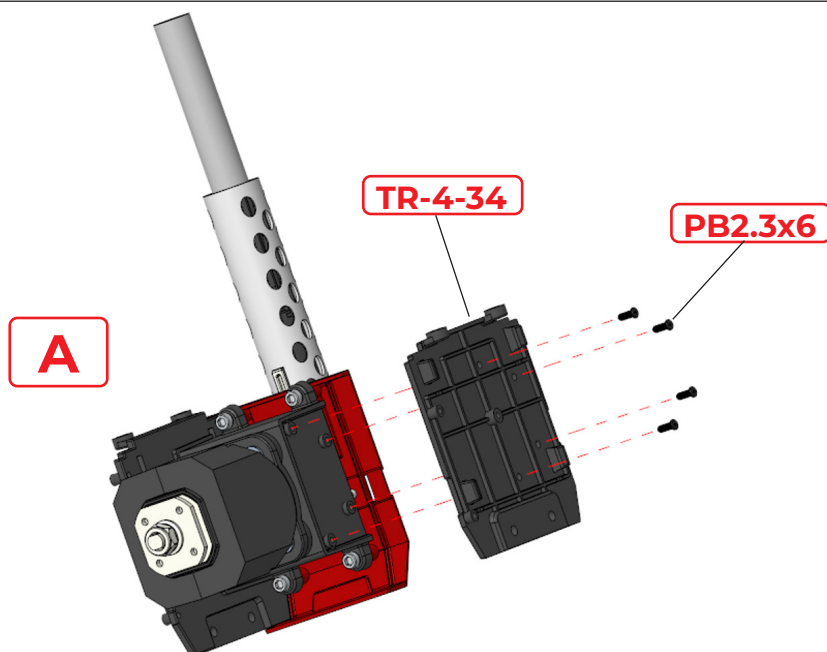

STEP 17

Secure TR-4-34 to A using 4x PB2.3x6 mm screws.

Assembling the Right Shoulder & Arm

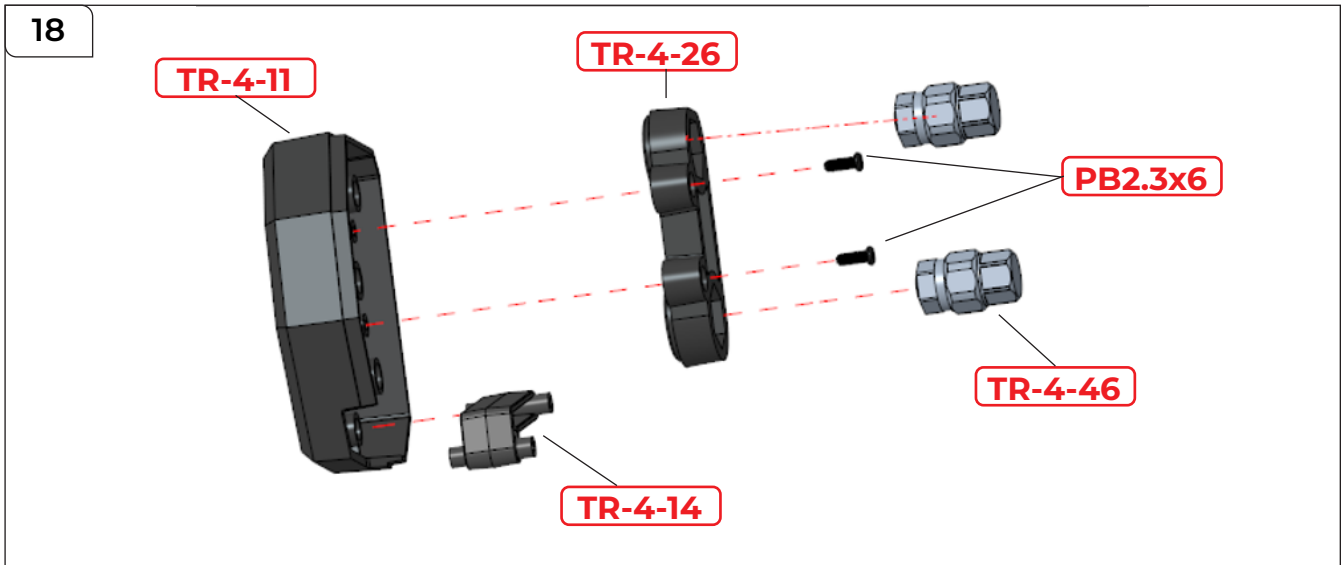

STEP 18

Attach TR-4-26 to TR-4-11 and secure them with 2x PB2.3x6 mm screws.

Attach TR-4-46 to TR-4-26.

Attach TR-4-14 to TR-4-11. **Do not glue** as this is a moving part.

This is now referred to as assembly A.

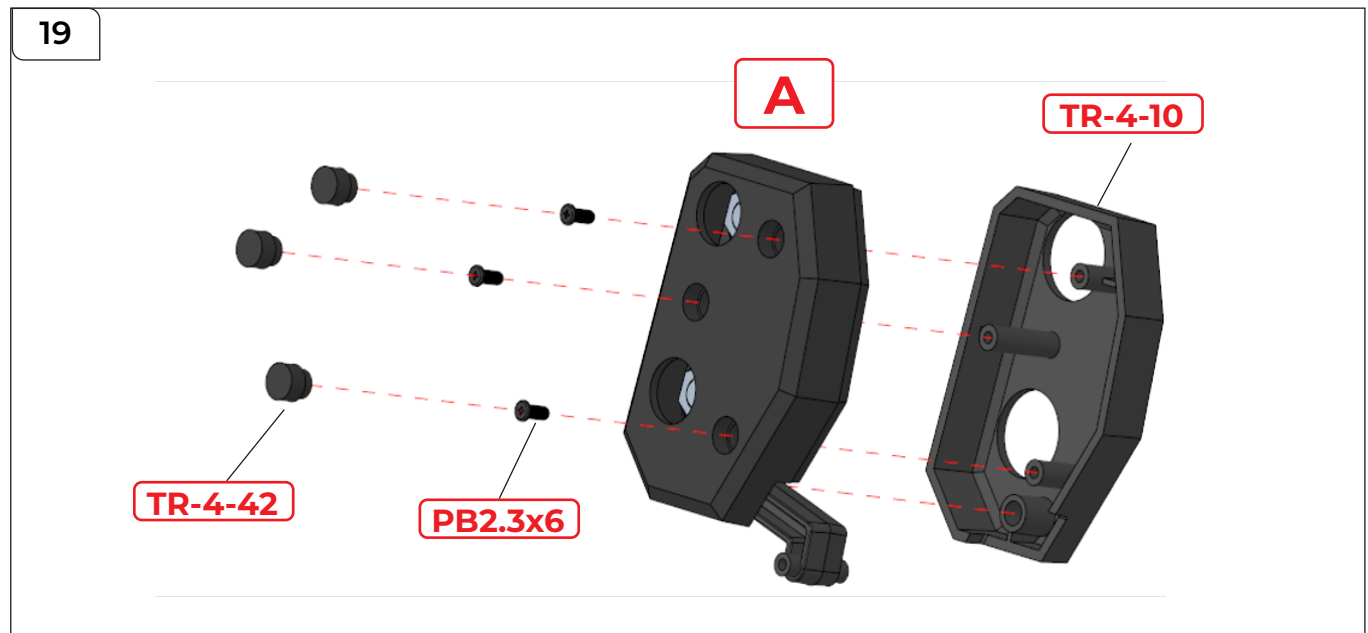

STEP 19

Attach TR-4-10 to assembly A and secure everything together using 3x PB2.3x6 mm screws. Then place 3x TR-4-42 caps over the screws.

Assembling the Right Shoulder & Arm

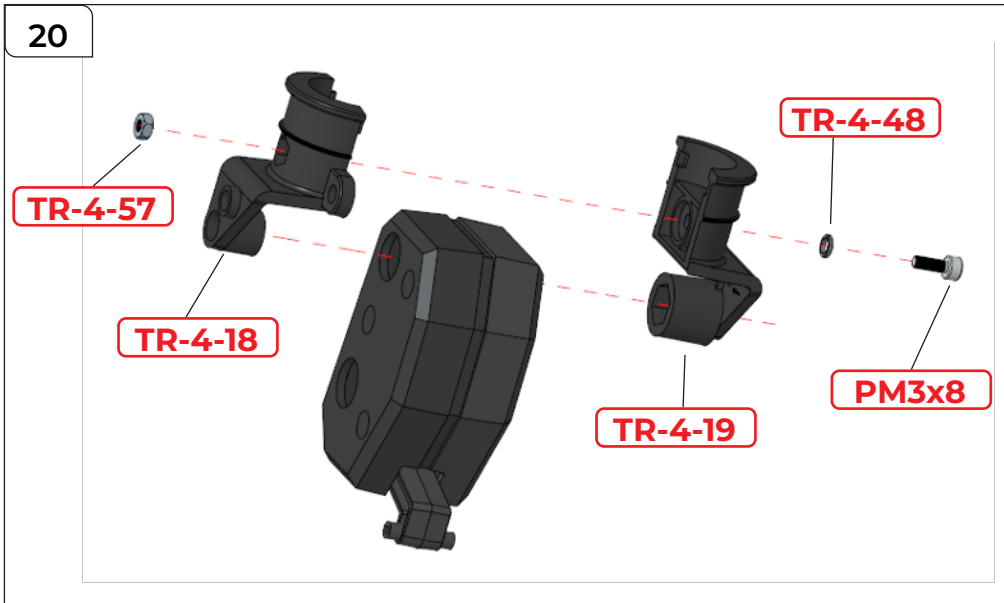

STEP 20

Attach TR-4-18 and TR-4-19 to A. Thread **washer TR-4-48** onto **1x PM3x8 mm screw** and feed through the assembly, securing from the opposite side using a **nut TR-4-57**.

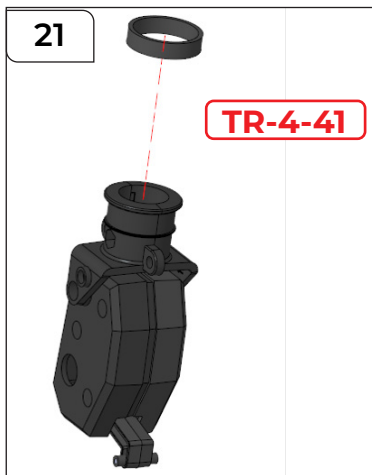

STEP 21

Place **TR-4-41** around the outside rim of the assembly, shown close-up in 21a.

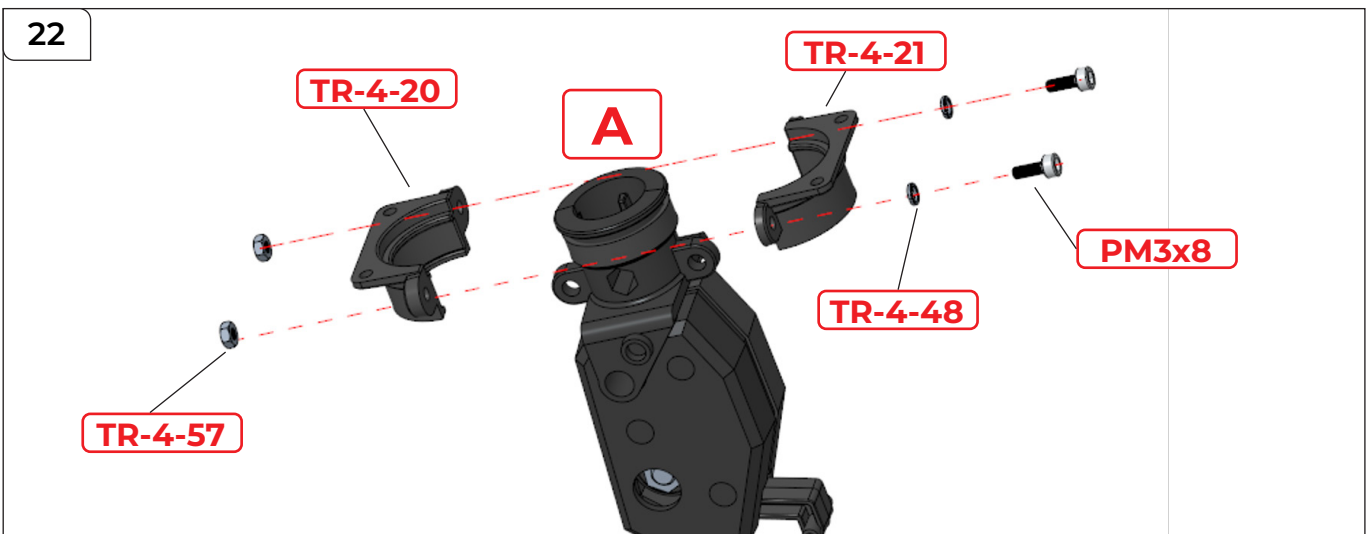

STEP 22

Attach **TR-4-20** and **TR-4-21** to A as shown. Thread **washer TR-4-48** onto a **PM3x8 mm screw** and make 2 sets. Push each screw with washer through the assembly as shown, securing them in place using **2x nuts TR-4-57**.

Assembling the Right Shoulder & Arm

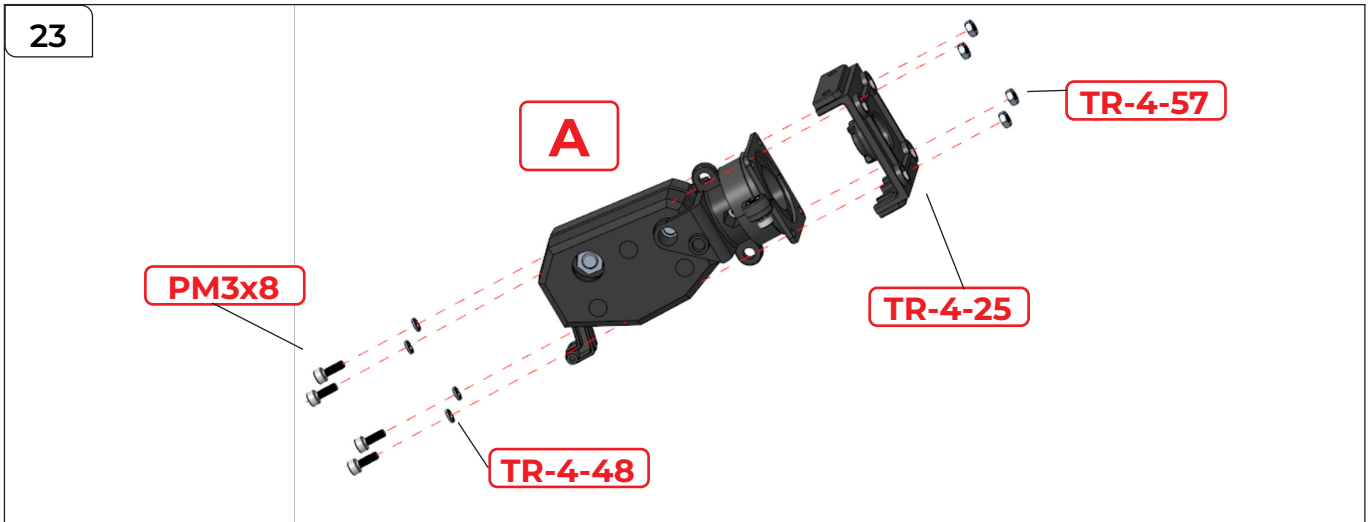

STEP 23

Attach **TR-4-25** to A as shown.

Thread **washers TR-4-48** onto **PM3x8 mm screws** and push them through the assembly as shown, securing them in place from the opposite side using **nuts TR-4-57**.

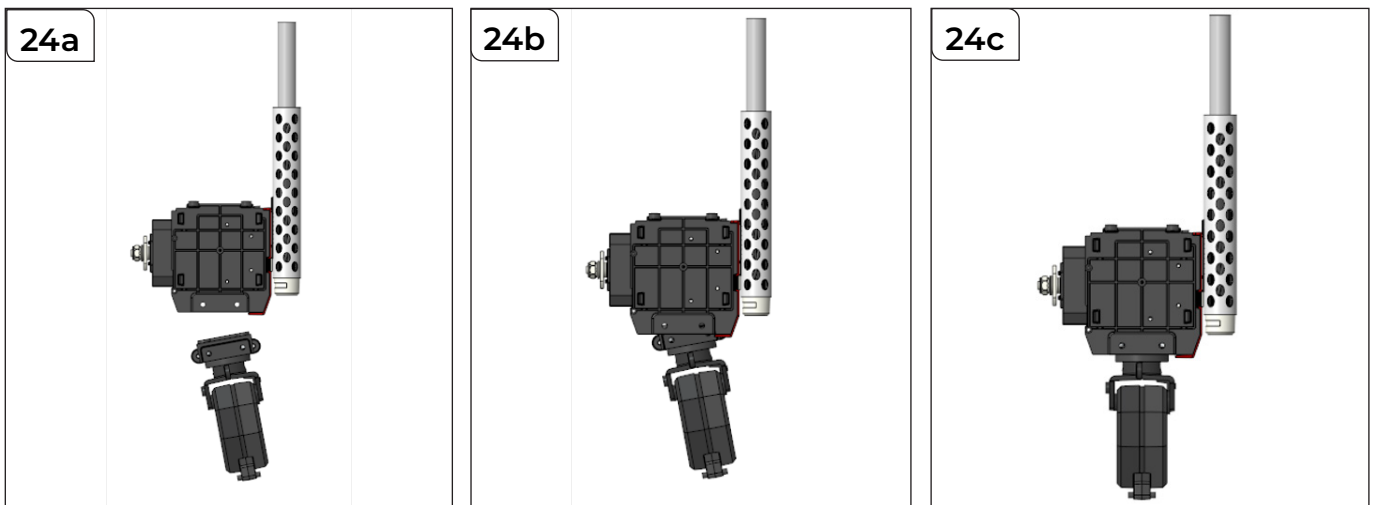

STEP 24

Attach the assembly from step 23 to the assembly from step 17. Push into position, lining up the screw holes. Start with one screw hole, get it into position, then follow with the second screw hole, as demonstrated by the sequence above.

Assembling the Right Shoulder & Arm

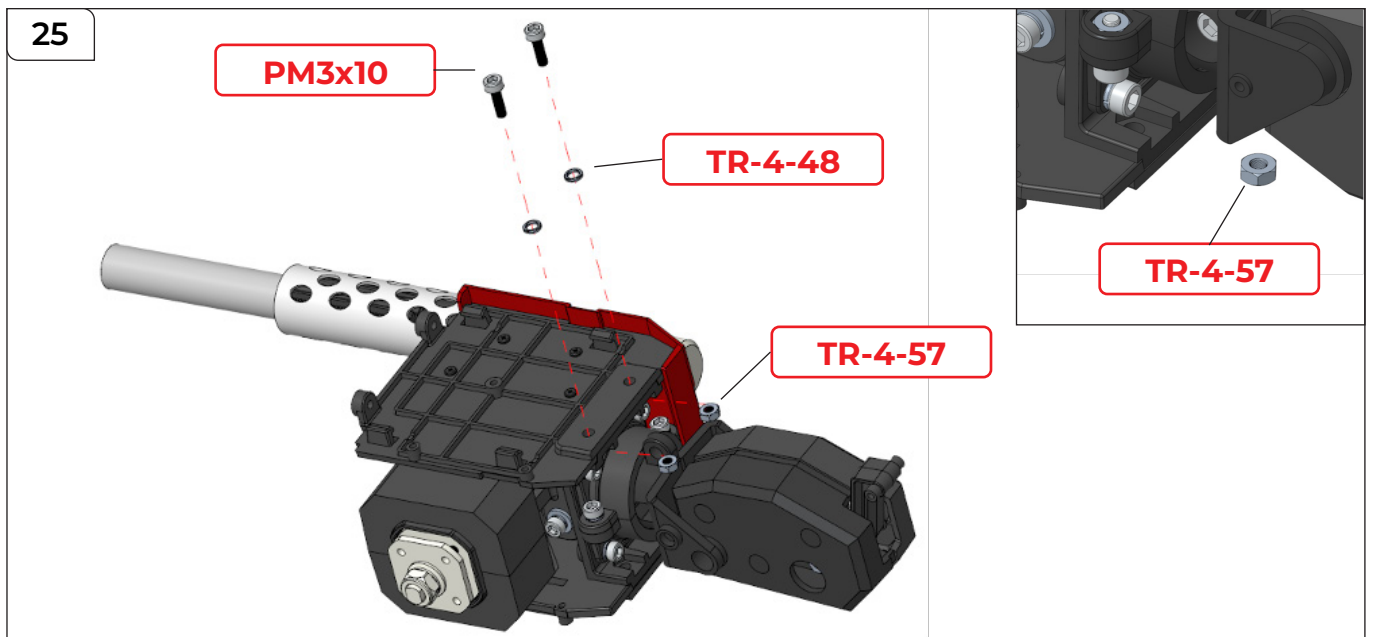
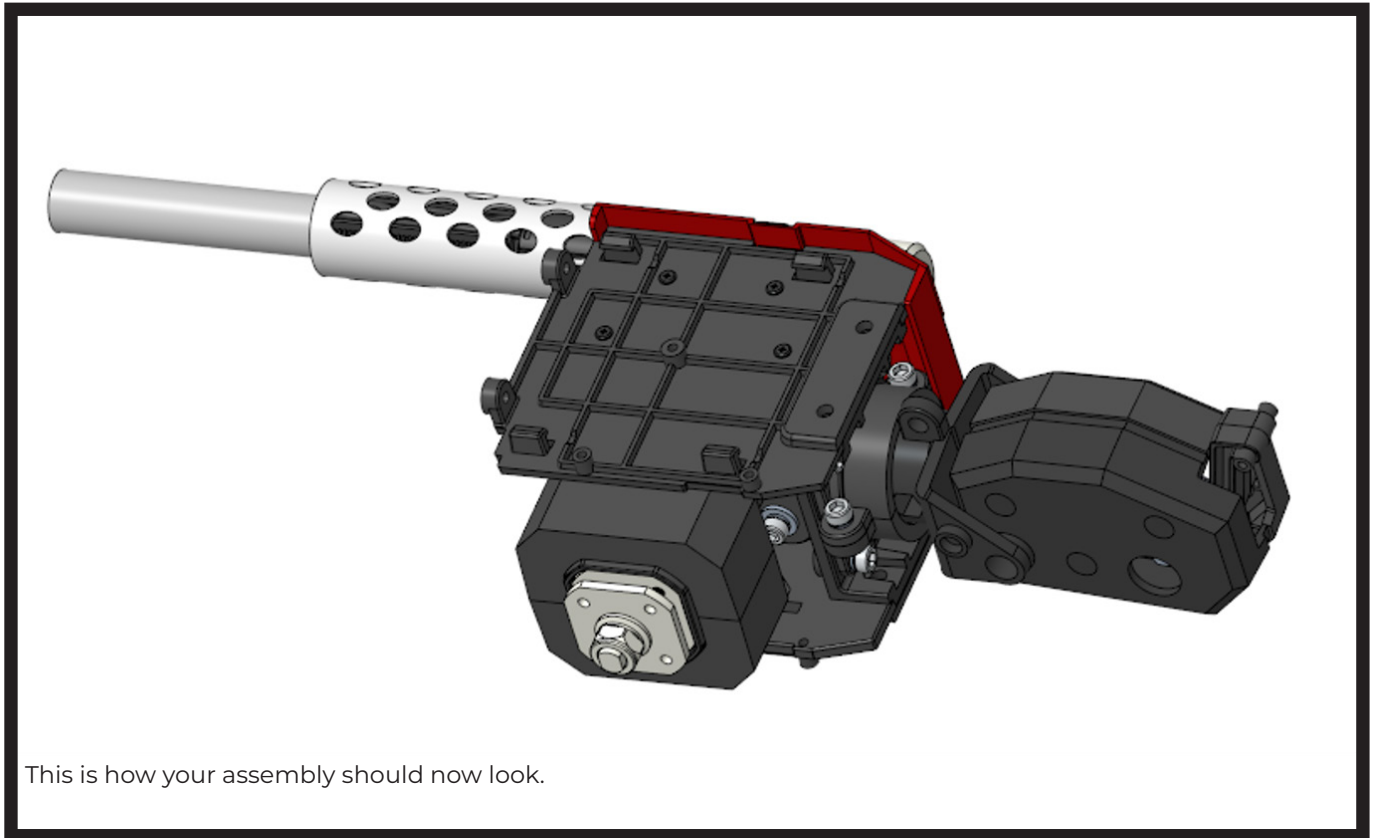

STEP 25

Start by placing **TR-4-57** into each notch (shown above right), then place washers **TR-4-48** onto 2 x **PM3x10** mm screws before screwing them into **TR-4-57** as shown.

Assembling the Right Shoulder & Arm

26

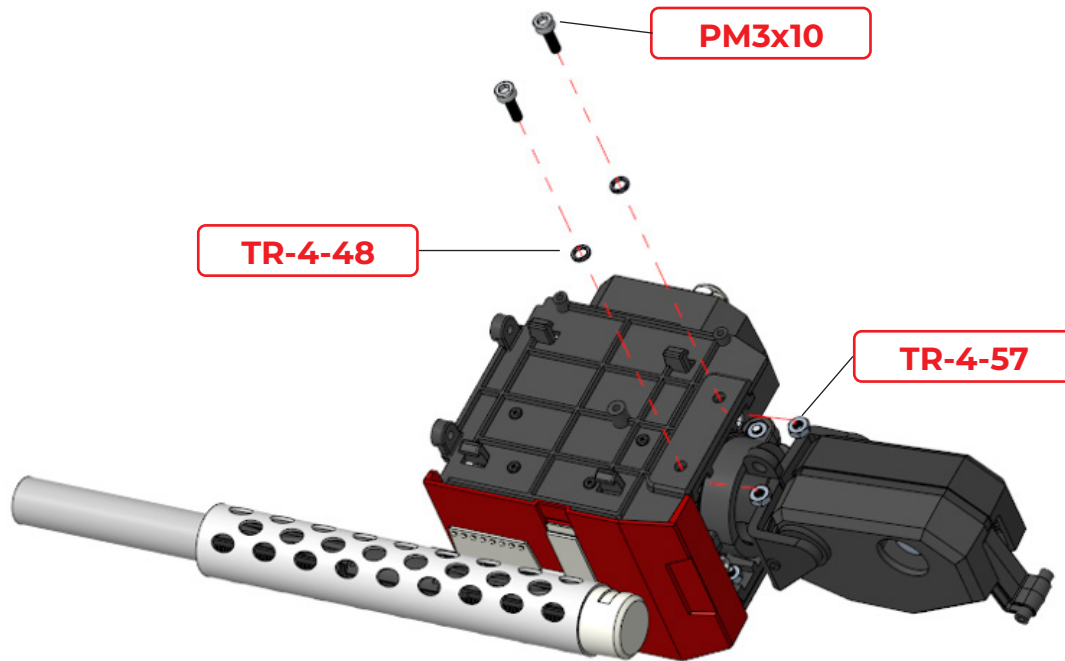

STEP 26

Turn the assembly over and repeat step 25 on the opposite side.

27

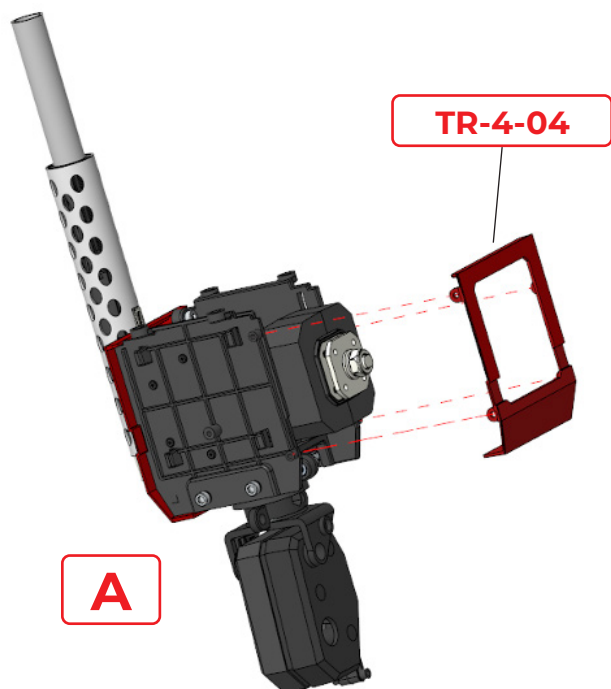

STEP 27

Position **TR-4-04** onto A.

Assembling the Right Shoulder & Arm

28

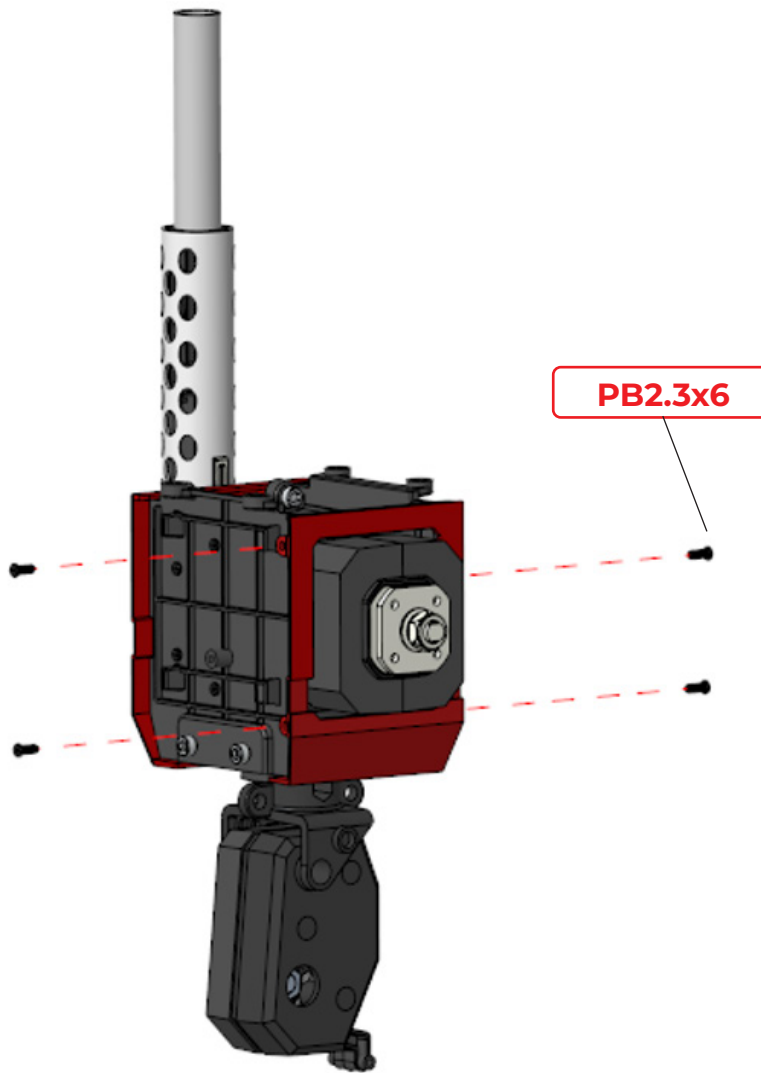

STEP 28

Secure the parts together using 4x PB2.3x6 mm screws.

Assembling the Right Shoulder & Arm

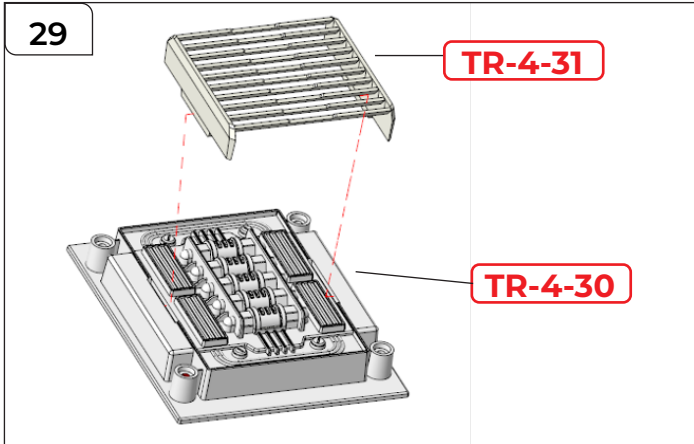

STEP 29

Attach TR-4-31 to TR-4-30 as shown.

STEP 30

Place TR-4-05 on top of TR-4-30 and secure it in place using 4x PWM2x6 mm screws.

Note: check the orientation of the blind window - shown in 30a - before completing the assembly. The louvres are horizontal and slope down and forwards from the back to the front.

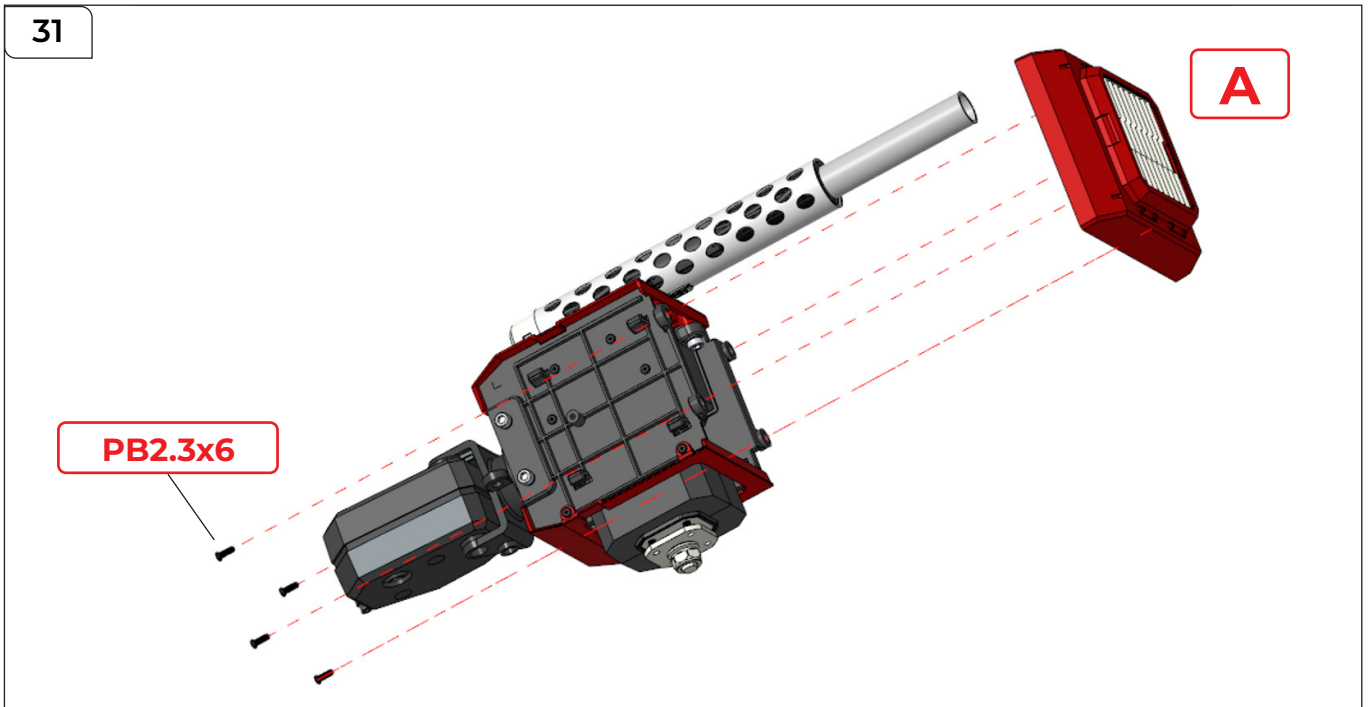
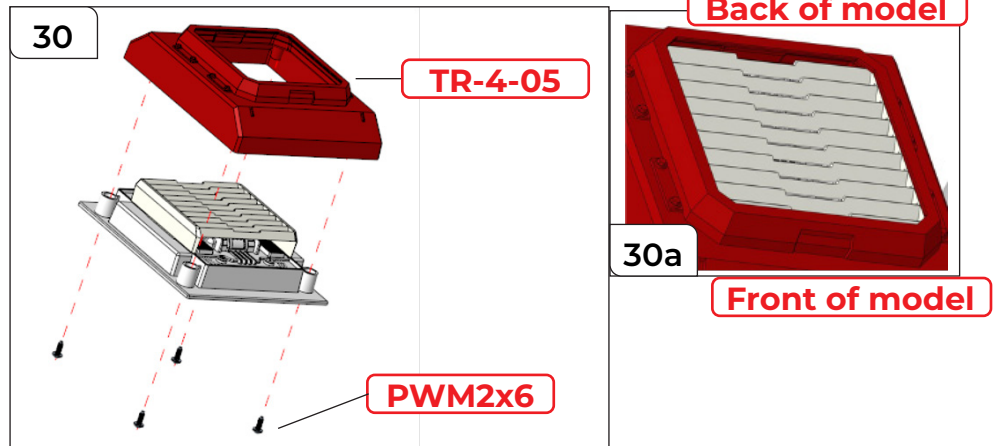

STEP 31

Place assembly A onto the shoulder assembly from step 28, securing it in place using 4x PB2.3x6 mm screws.

Assembling the Right Shoulder & Arm

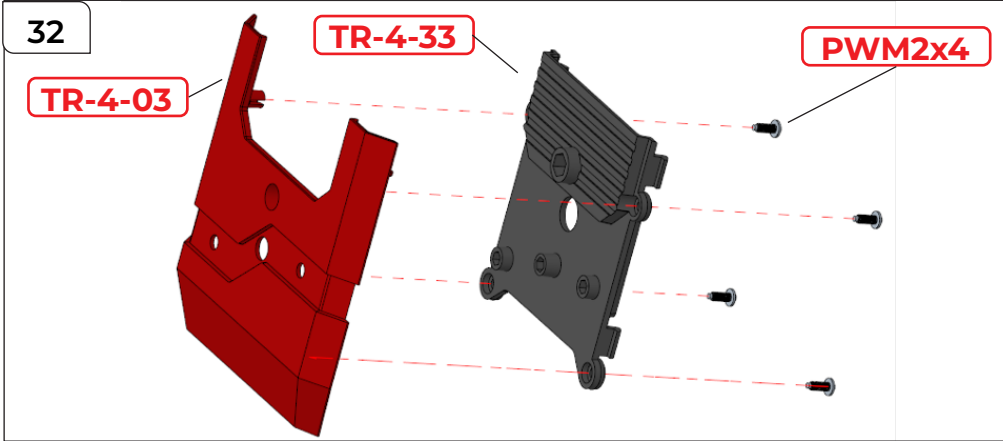

STEP 32

Place TR-4-33 onto TR-4-03 and secure them together using 4x PWM2x4 mm screws as shown.

STEP 33

Place the assembly from step 32 onto the shoulder assembly from step 31, sliding it into position in the direction of the arrow.

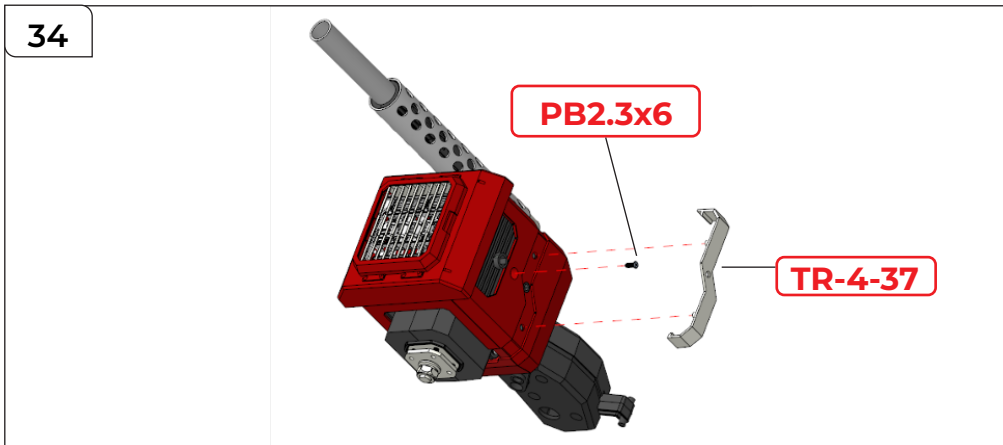
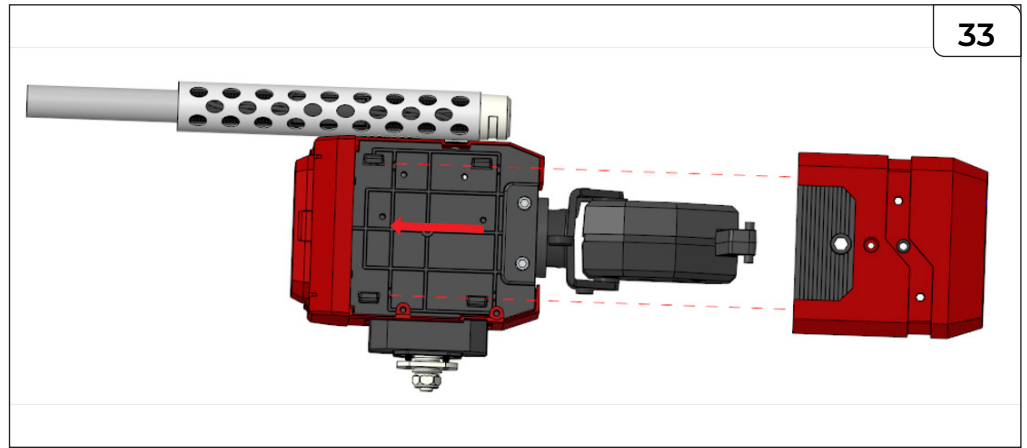

STEP 34

Secure the parts from step 33 in position using a PB2.3x6 mm screw, then push TR-4-37 into A until it clicks into position.

STEP 35

Place TR-4-29 onto TR-4-40 and secure them using a PB2x4 mm screw.

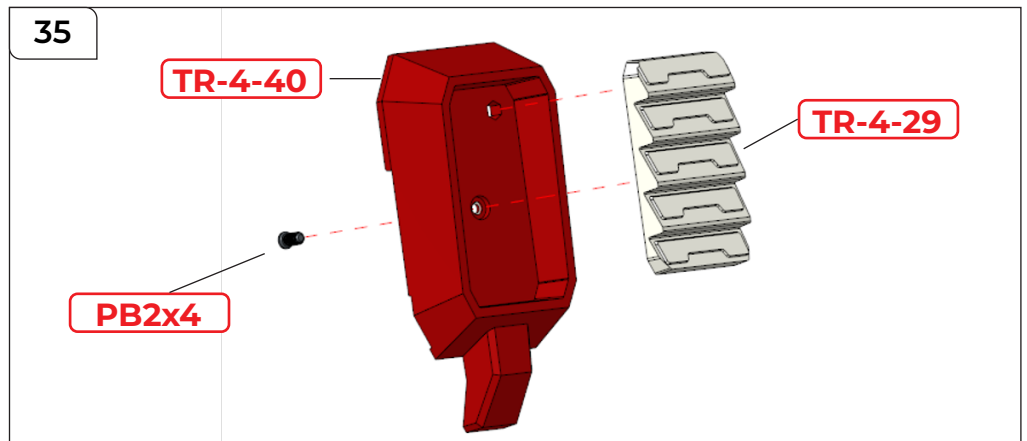

Assembling the Right Shoulder & Arm

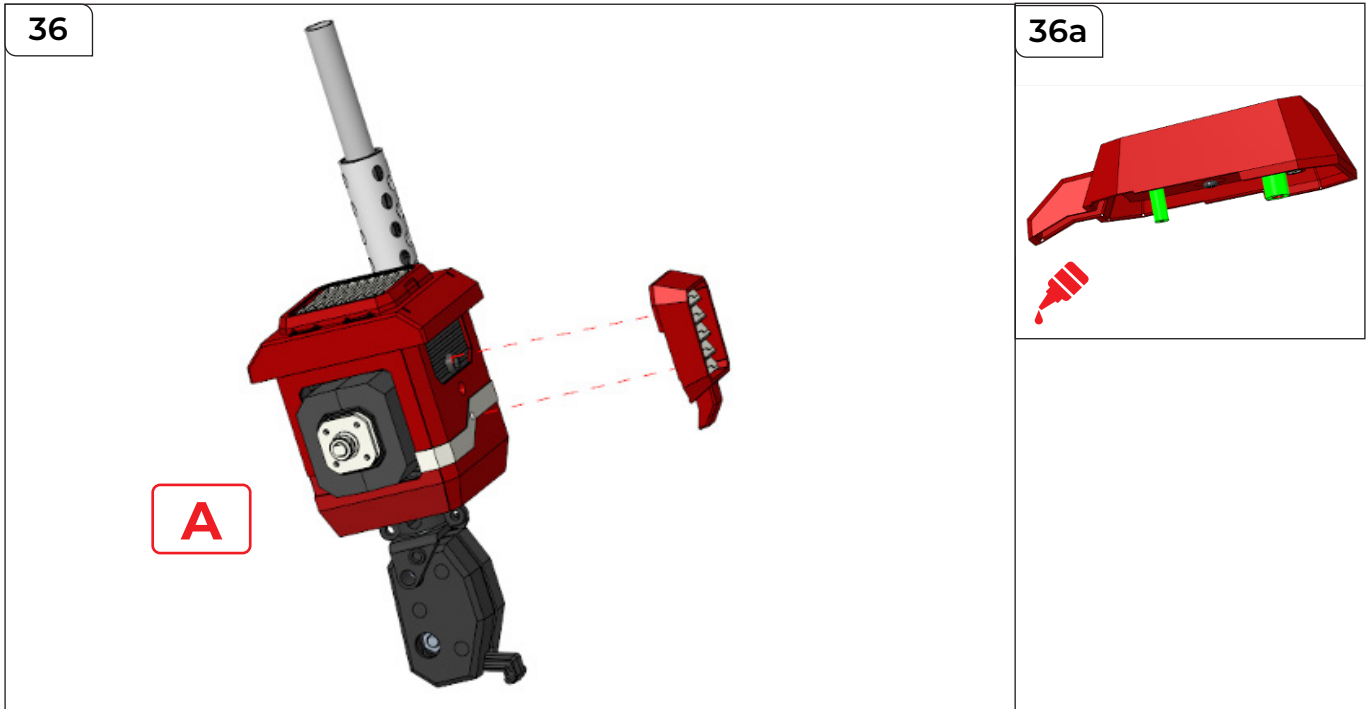

STEP 36

Apply a drop of super glue to the assembly from step 35 (shown in green in 36a) before attaching it to A as shown.

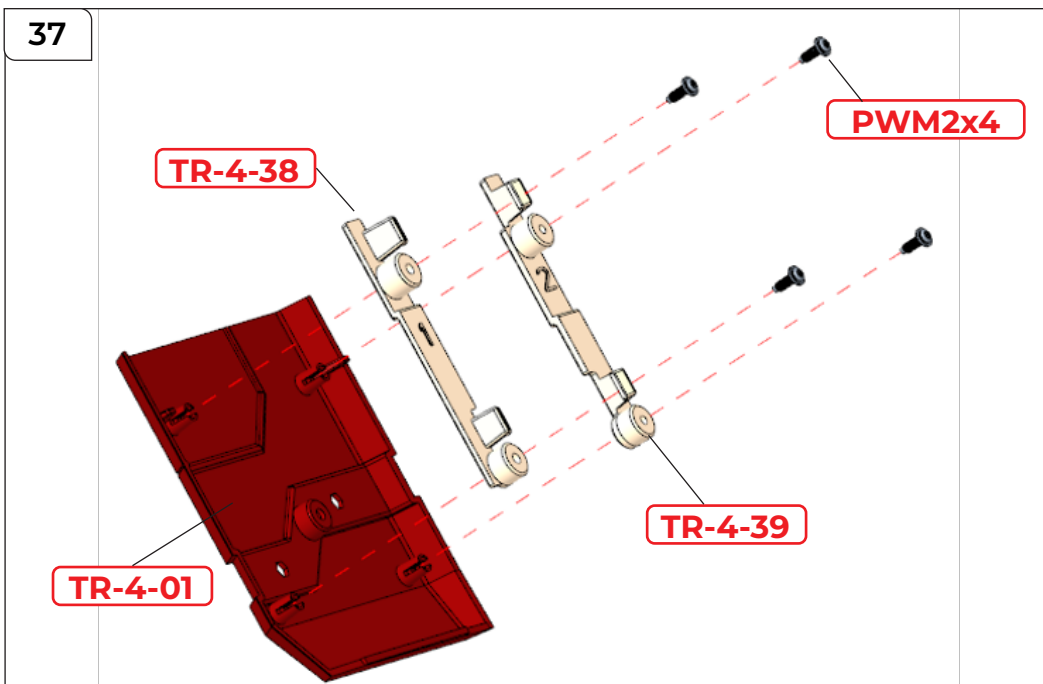

STEP 37

Place TR-4-38 and TR-4-39 on TR-4-01 as shown, securing them with 4x PWM2x4 mm screws.

Assembling the Right Shoulder & Arm

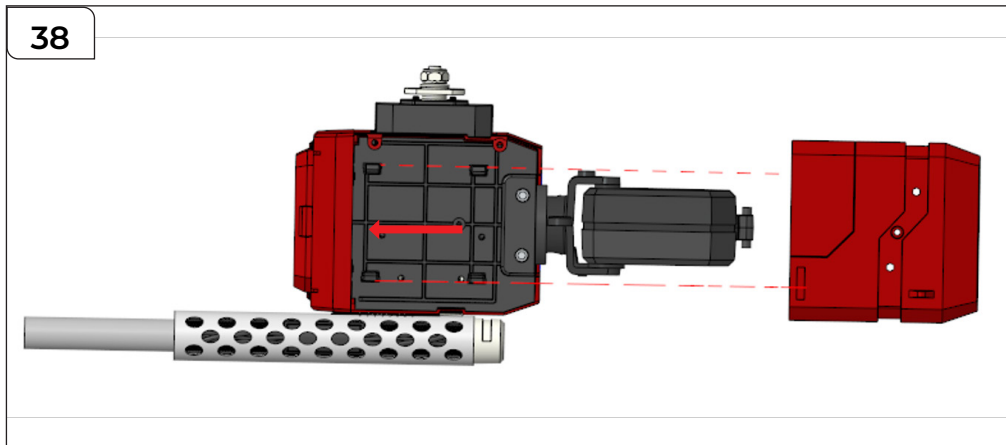

STEP 38

Place the assembly from step 37 onto the shoulder, sliding them into position in the direction of the arrow.

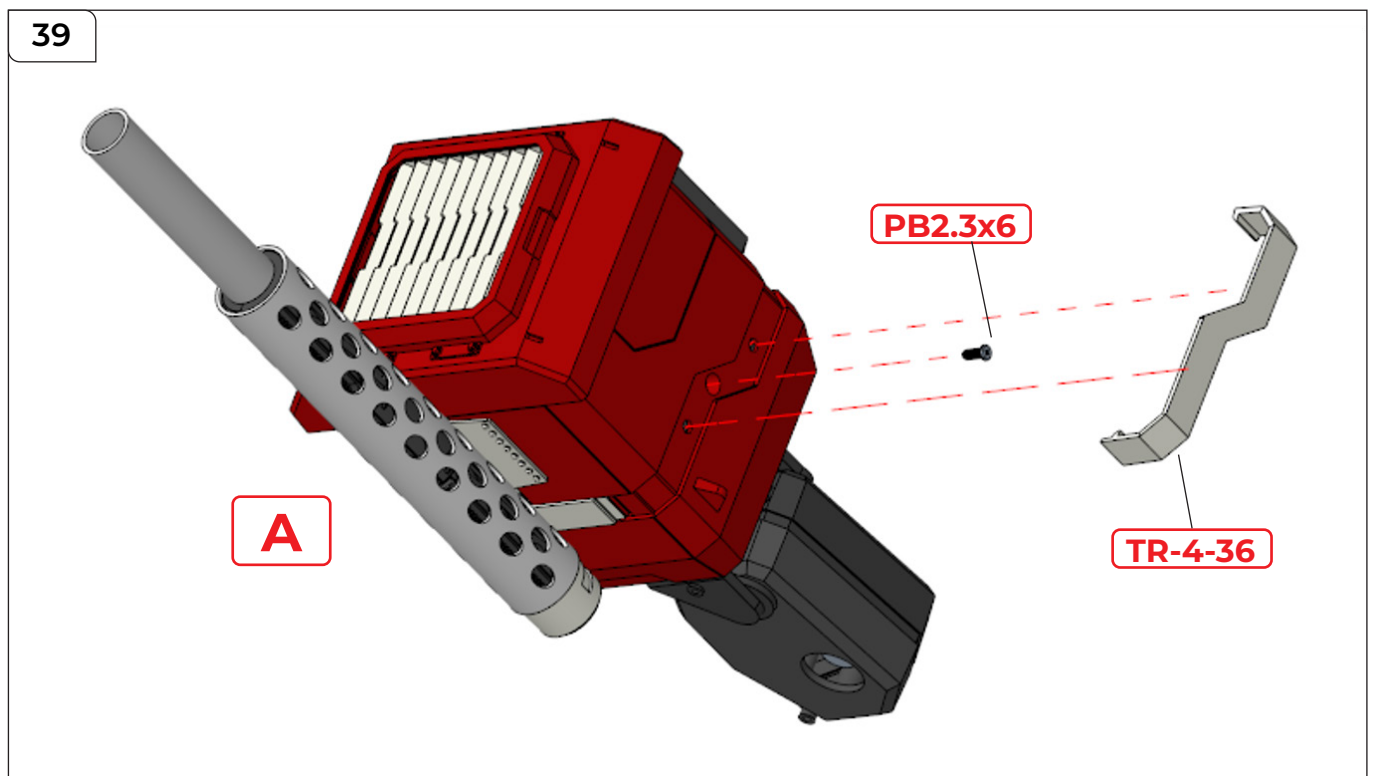

STEP 39

Secure the parts from step 38 in place using a **PB2.3x6 mm** screw. Push **TR-4-36** into A as shown until it clicks into place.

Assembling the Right Shoulder & Arm

40

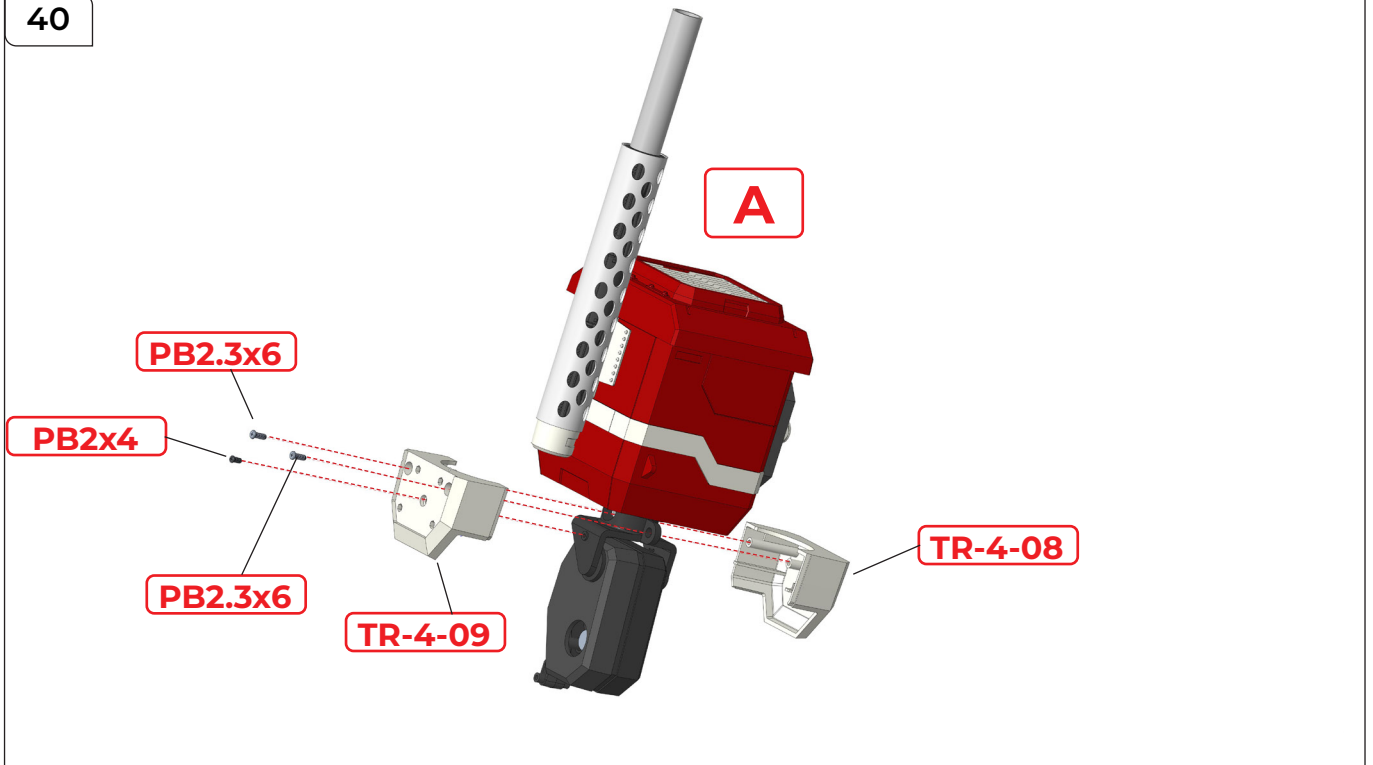

STEP 40

Position TR-4-08 and TR-4-09 either side of A as shown. Secure them together using 2x PB2.3x6 mm screws in the outer holes, and 1x PB2x4 mm screw in the central hole.

41

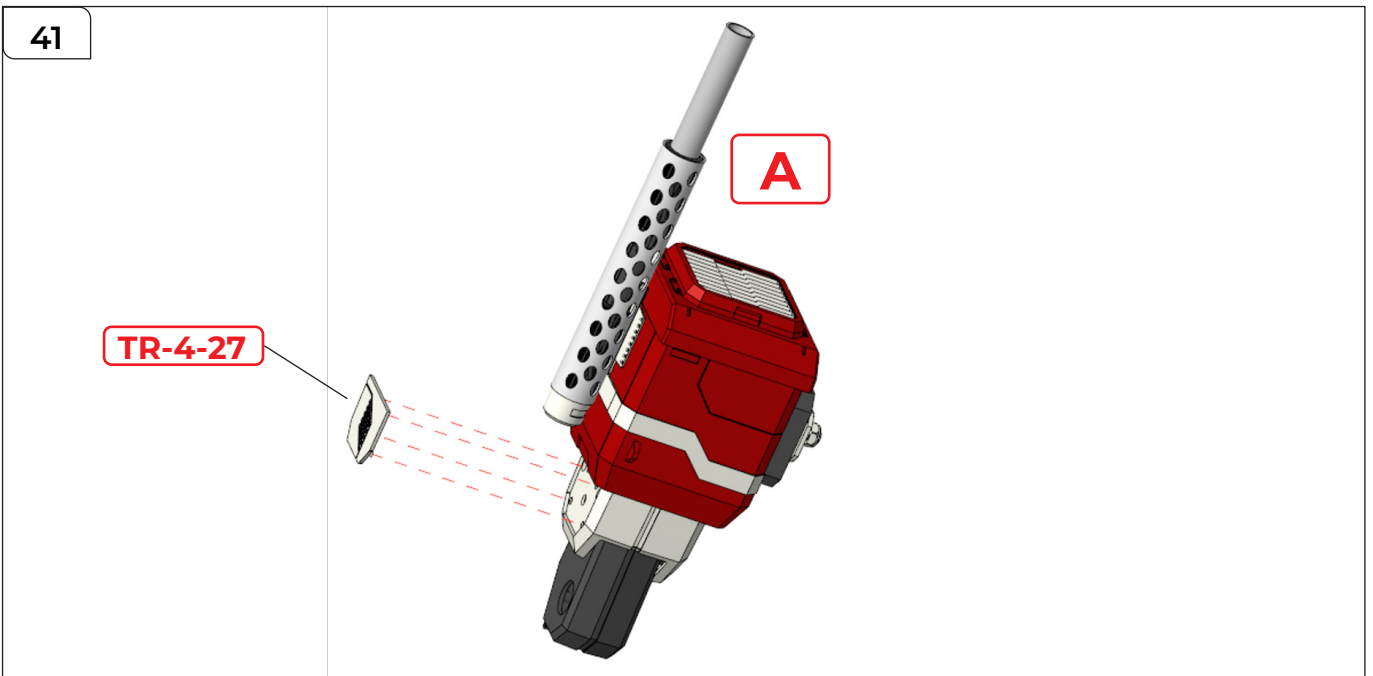

STEP 41

Attach TR-4-27 to A.

Assembling the Right Shoulder & Arm

PACK 4 COMPLETE

