

MITSUBISHI A6M ZERO FIGHTER



Pack 06 | Build Instructions

Your 1:18 model of the Japanese Zero is reproduced in the most exquisite detail, with electronics allowing you to recreate aeronautical operations such as take-off and landing, turning, firing and night combat. Lights, machine-gun and propeller sounds bring your legendary fighter plane to life.

In your sixth model pack, you will assemble:

**STAGE 46: ATTACHING THE TYPE 99
MKII 20 MM MACHINE GUN TO THE
RIGHT LANDING GEAR**

**STAGE 47: ATTACHING THE RIGHT LANDING
GEAR AND MOTOR**

STAGE 48: INSTALLING THE RIGHT AILERON

**STAGE 49: INSTALLING RIGHT WING
SUPPORT FITTINGS, THE EXTERNAL PANEL
FRAME AND THE COCKPIT**

**STAGE 50: ASSEMBLING THE TAIL GEAR
RETRACTION MECHANISM**

**STAGE 51: CHECKING THE ELEVATOR
SERVOMOTOR**

**STAGE 52: ASSEMBLING THE RIGHT
LANDING GEAR (1)**

**STAGE 53: TESTING THE SERVOMOTOR
AND ASSEMBLING THE TAIL GEAR
RETRACTION MECHANISM (3)**



There are excellent videos showing how to build the Zero [here](#).

Advice from the experts

Spare screws are included with each part. Occasionally, you may be instructed to keep spare or unused screws for a later stage.

Keep these spares in a safe place and label them correctly.

Please make sure you don't mix up the screws. They look quite similar, but the threads do vary slightly. Using the wrong screws may damage the parts.

When securing parts together using multiple screws, fit each screw loosely to ensure all the parts are correctly aligned before gently tightening them firmly, but not overtight, in the order in which you placed them.

The screwdriver can be magnetised by stroking it with a magnet (fridge magnet, etc.) enabling it to hold the screws and make assembly easier.

If a screw is tight going into a metal part, do not force it as you may shear the head off. Remove it and put a tiny smear of Vaseline, soap or light oil on the thread. That will lubricate it and make it easier to drive home.

During the course of this build, you will receive many pieces that you will assemble immediately – following the instructions in the corresponding stage – and other pieces that you should store safely to one side, for use in future assembly stages.

When gluing parts together, glue may be applied to either of the two parts. Some experts find it easier to apply glue to a hole rather than a pin. Choose a method that works best for you.

It's a good idea to test fit your parts so that you can check their positioning before gluing.

Not suitable for children under the age of 14. This product is not a toy and is not designed for use in play. Keep the parts out of the reach of small children. Some parts may have sharp edges. Please handle them with care.

Stage 46: Attaching the Type 99 MkII 20 mm Machine Gun to the Right Landing Gear



Stage 46 Assembly
 Landing Gear & Machine Gun

In this stage we'll be installing the landing gear limit switch as well as assembling the Type 99 mk II 20 mm machine gun and then attaching this to the landing gear frame.

STAGE 46 PARTS

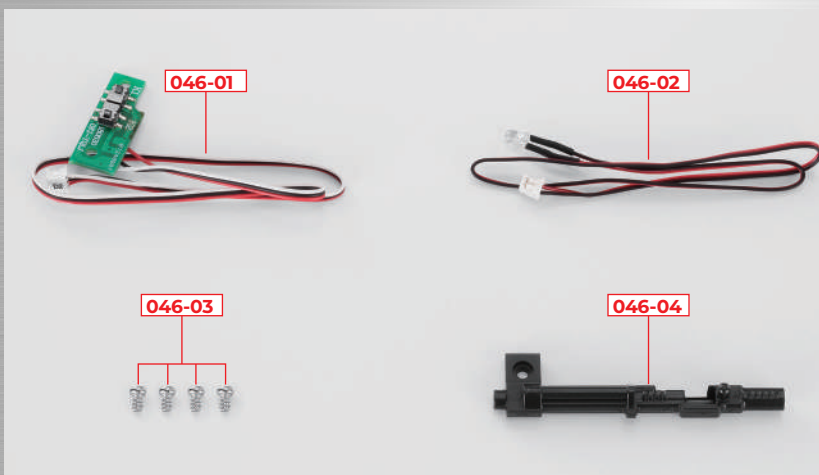

PARTS LIST

	PART	No.	MATERIAL
<input type="checkbox"/>	046-01	1	Switch board
<input type="checkbox"/>	046-02	1	LED
<input type="checkbox"/>	046-03	4 (1 spare)	Steel
<input type="checkbox"/>	046-04	1	ABS resin

You will also need: tweezers, screwdriver, needle-nose pliers

STEP 1

Attaching the landing gear limit switch

← : Glue
- - - : Don't Glue

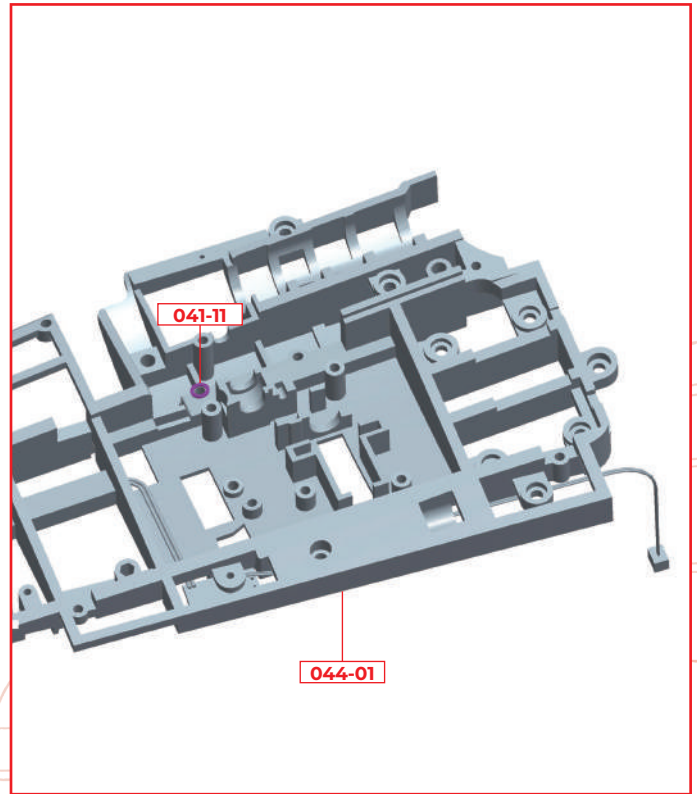
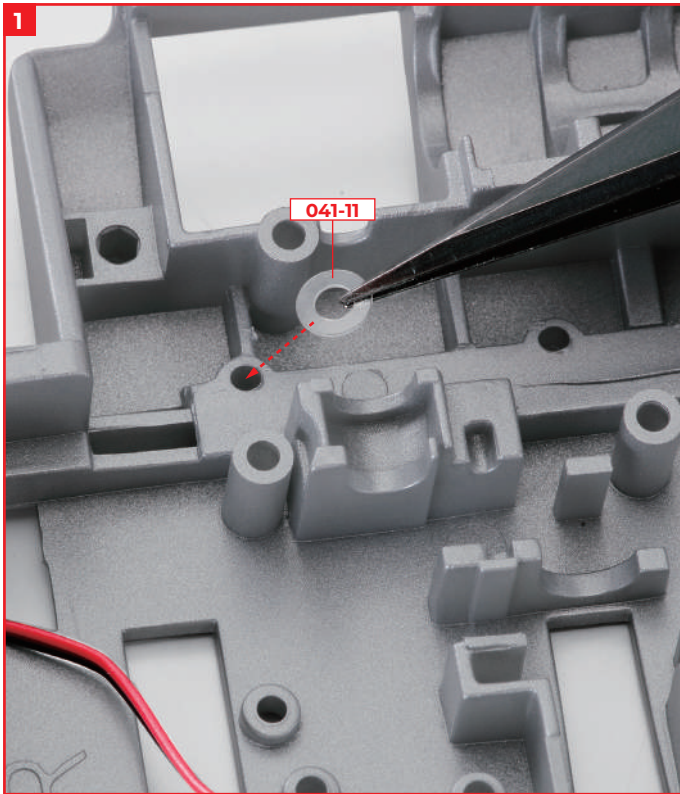

Place the washer **041-11** on the right wing frame **044-01** so that the holes match.

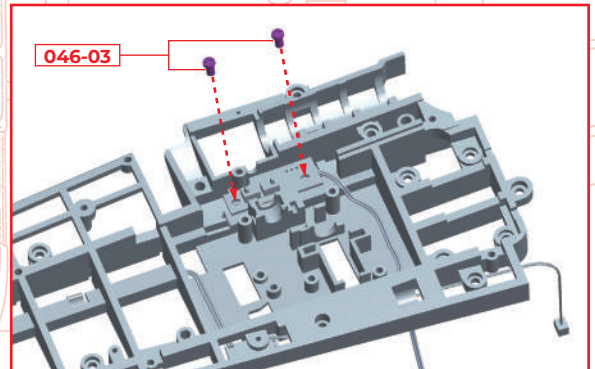
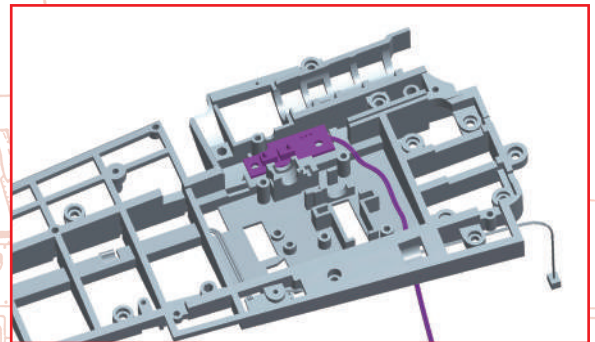
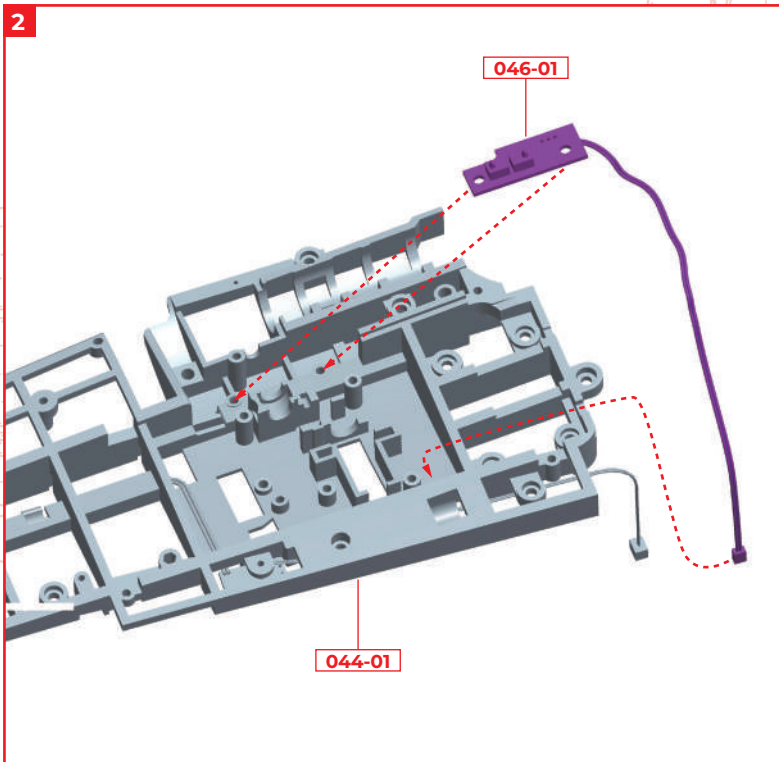

Place the right landing gear limit switch **046-01** on the right wing frame **044-01**, and fix it with two screws **046-03**. The cord of the switch **046-01** should be fed out through the hole of the wing frame **044-01**. The screw on the left is fixed by sandwiching the washer **041-11**, so be careful not to shift the washer **041-11**.

STEP 2

Installing the right landing gear

← : Glue
 - - - : Don't Glue

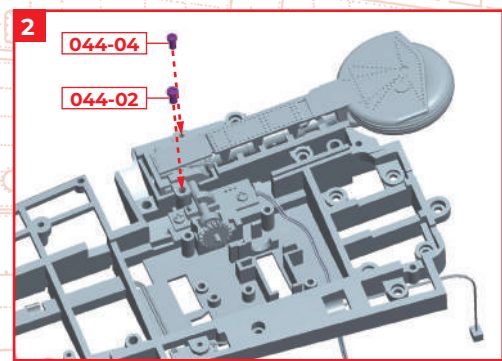
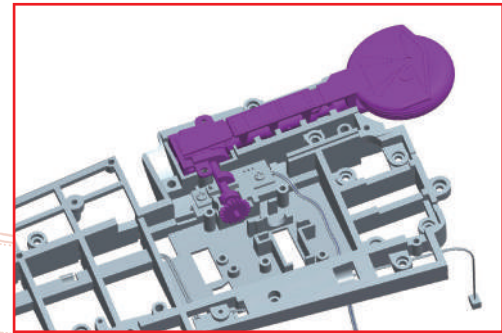
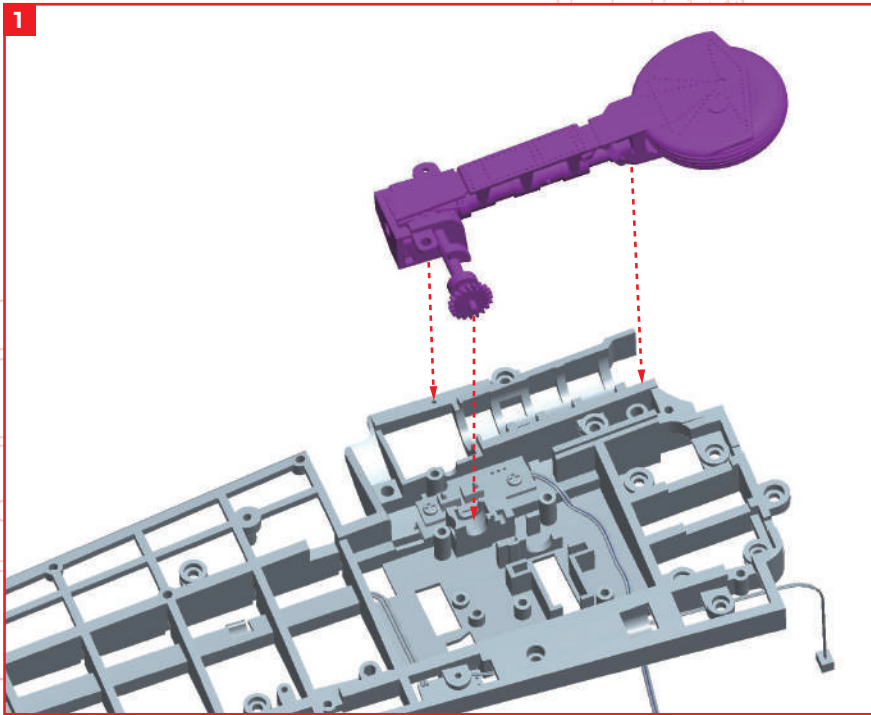

Fit the right landing gear assembled in stage 43 into the right wing frame 044-01.

Fix the right landing gear with 1 x 044-02 (thick one) and 1 x 044-04 (thin one) screw that came with stage 44.

STEP 3

Assembling and attaching the Type 99 mkII 20 mm machine gun

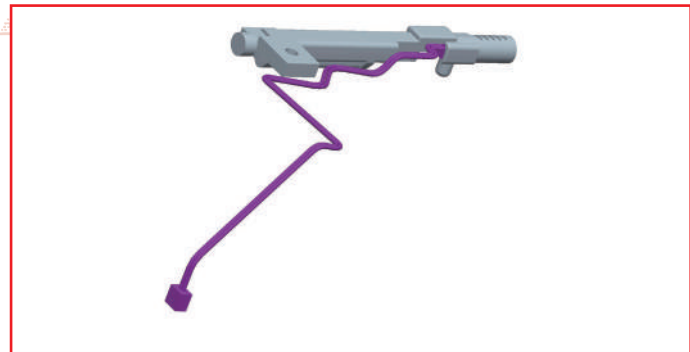
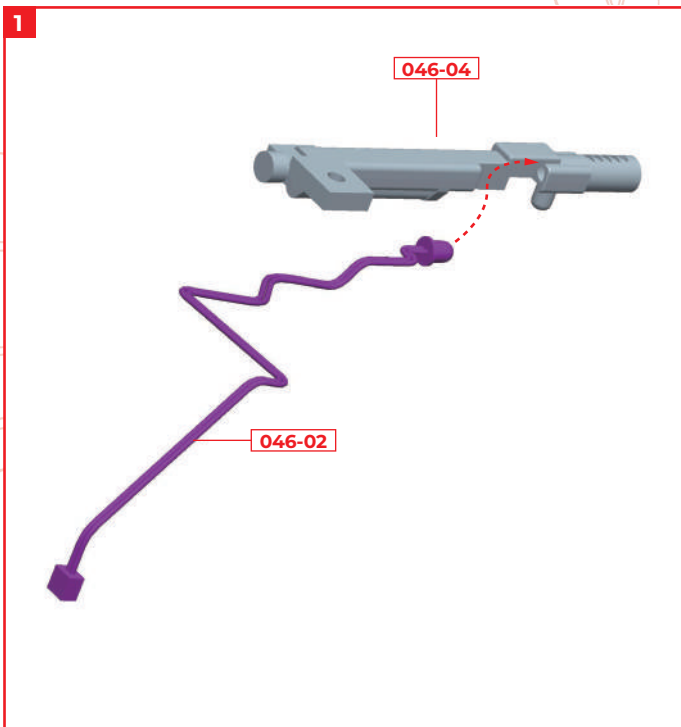

NOTE



Since the LED has a hard metal wire, if you try to install it as it is, the metal wire will get in the way. Hold the area just below the LED with needle-nose pliers and bend the metal wire with your fingers.

Insert LED 046-02 into the Type 99 20-millimeter machine gun (right) 046-04.

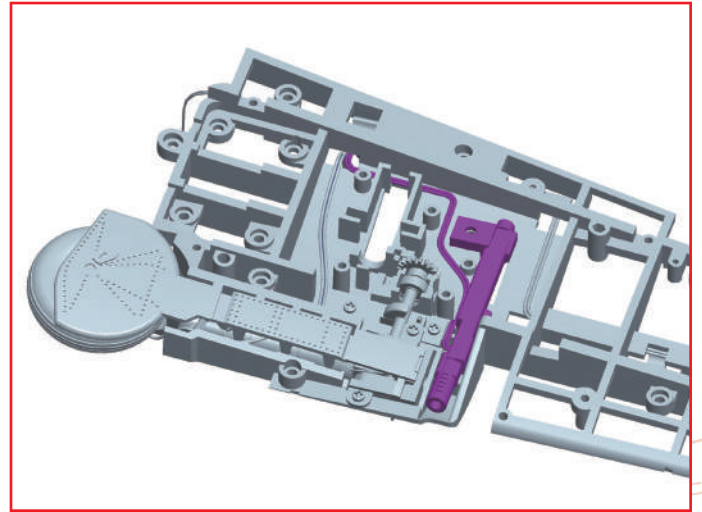
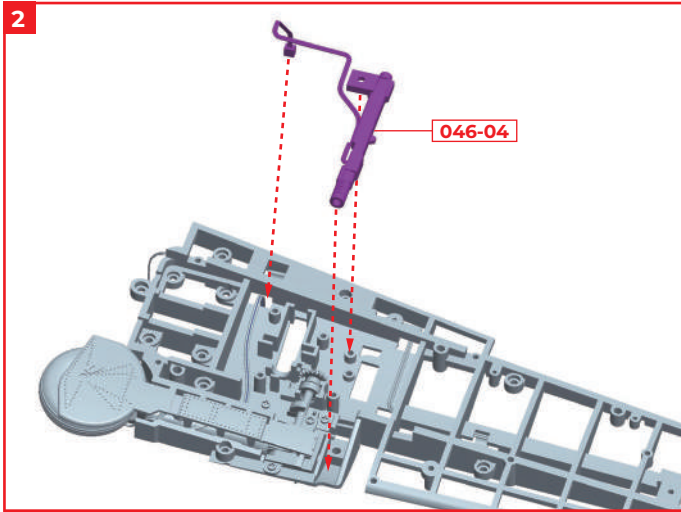

The machine gun (right) 046-04 assembled in 1 is installed in the right main wing frame 044-01. The wire of LED 046-02 should be fed through the same hole as the wire of the right landing gear limit switch 046-01.

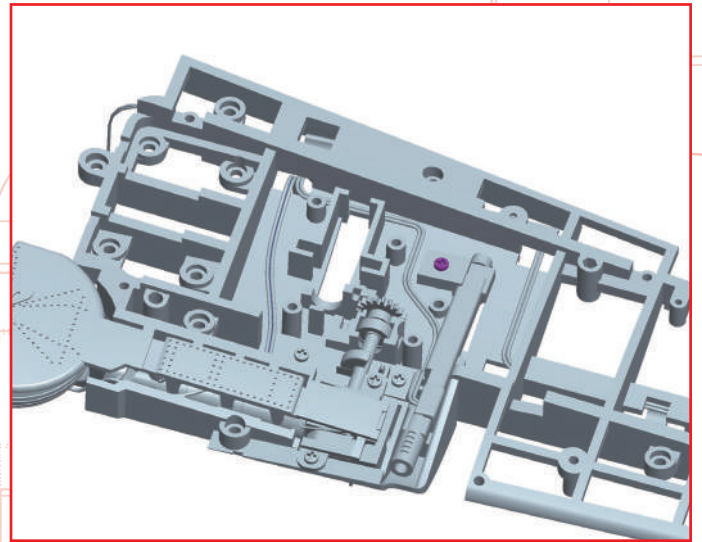
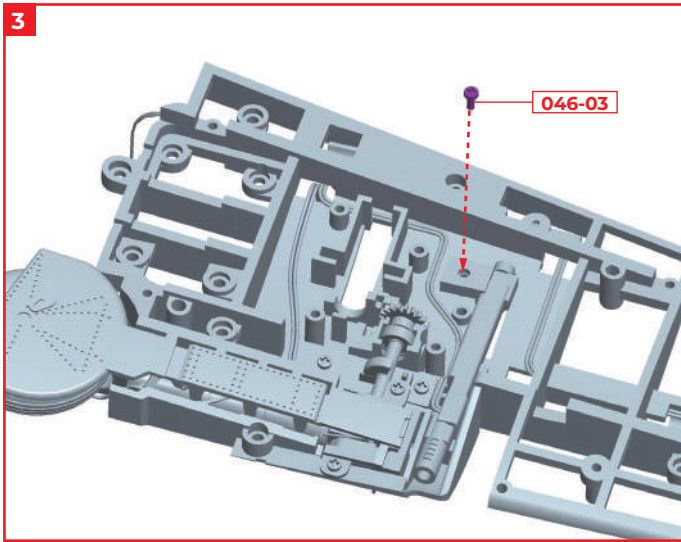

The machine gun 046-04 is fixed with 1 x 046-03 screw .

STAGE COMPLETE

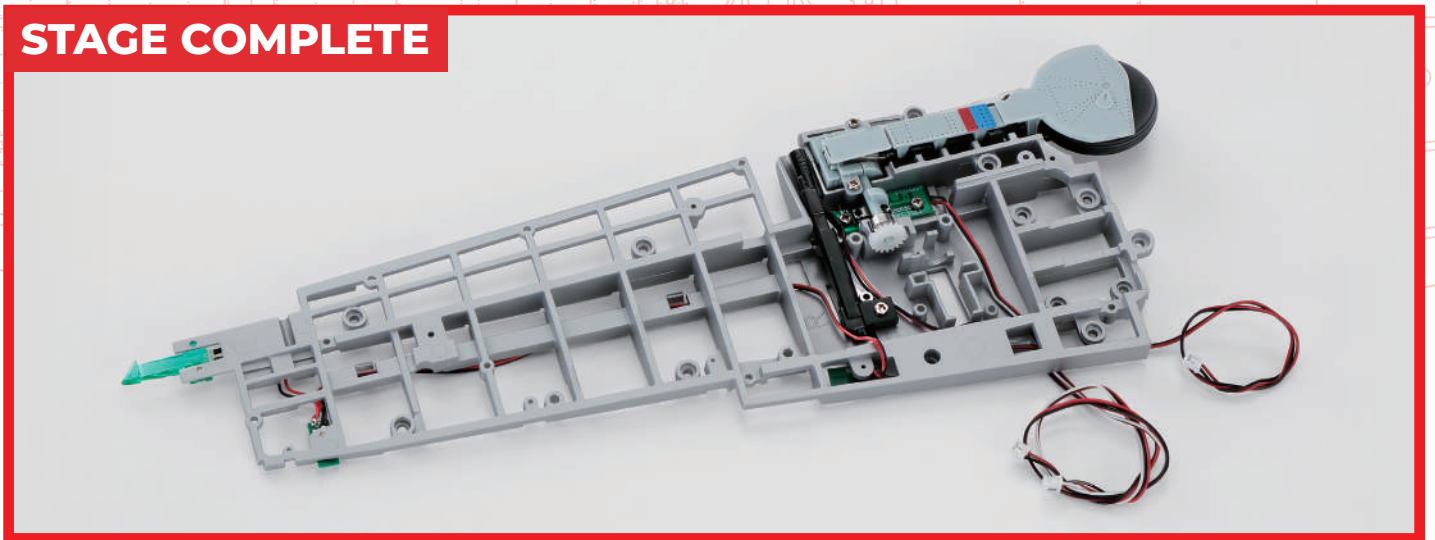

Stage 47: Attaching the Right Landing Gear and Motor

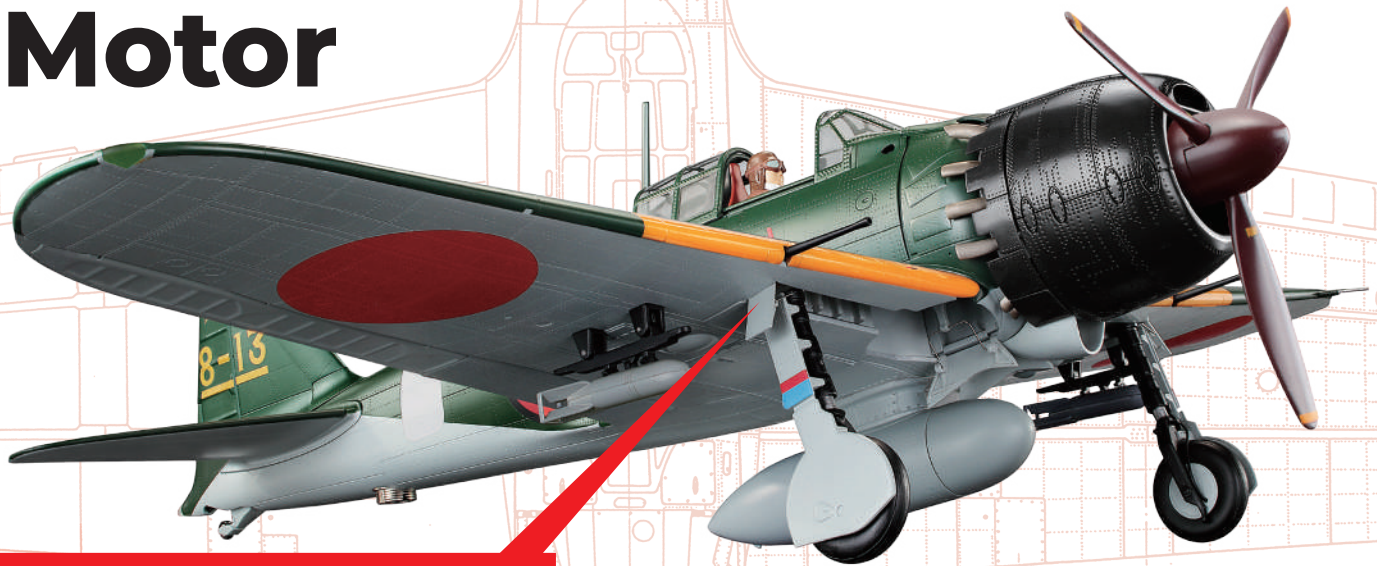

Stage 47 Assembly

Right Landing Gear Motor

In this stage we'll attach the right landing gear as well as the motor (which drives this side forward) to the left wing frame. Be careful when installing the gears and make sure the motor gears properly engage.

STAGE 47 PARTS

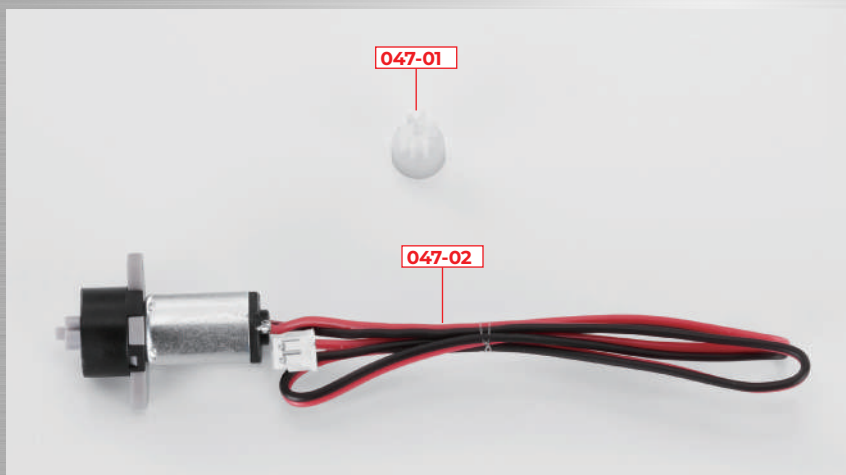

You will also need: screwdriver

PARTS LIST

	PART	No.	MATERIAL
<input type="checkbox"/>	047-01	1	Plastic
<input type="checkbox"/>	047-02	1	Motor

STEP 1

Attaching the right landing gear and motor

← : Glue
- - - : Don't Glue

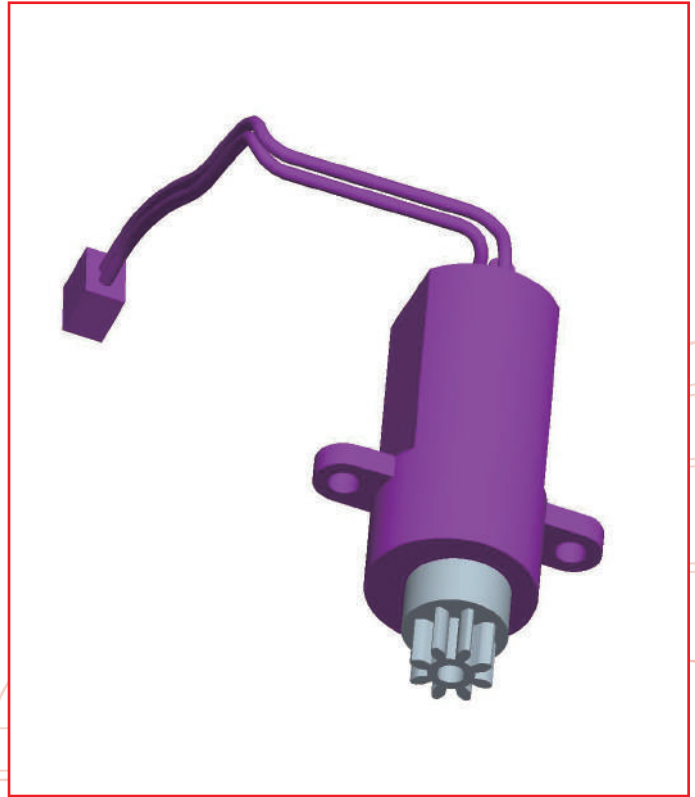
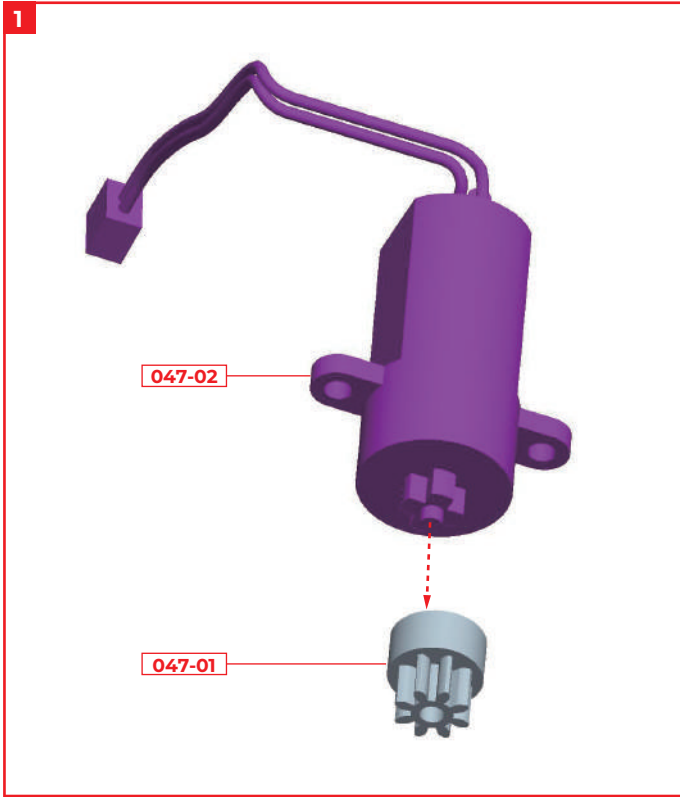

Fit gear 047-01 into motor 047-02. Pay attention to the direction

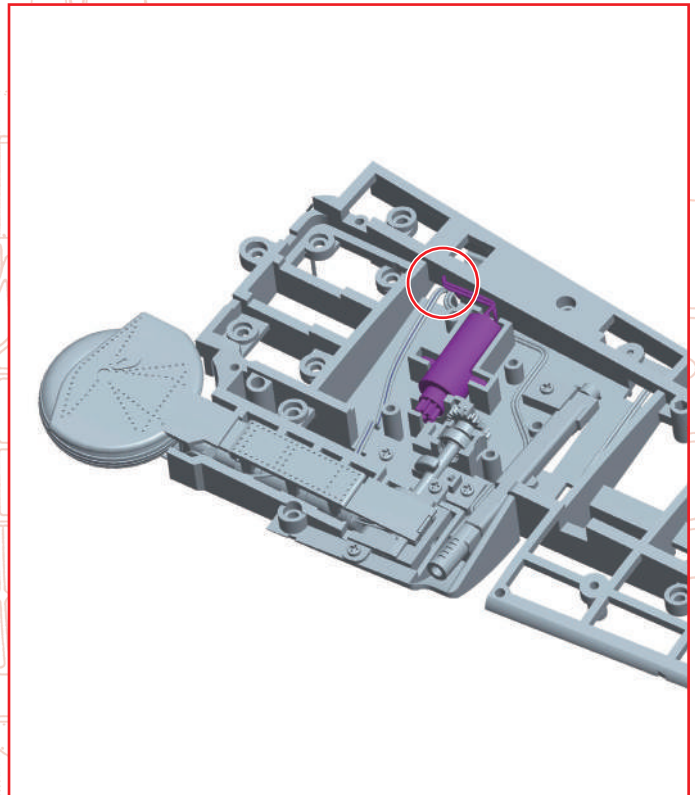
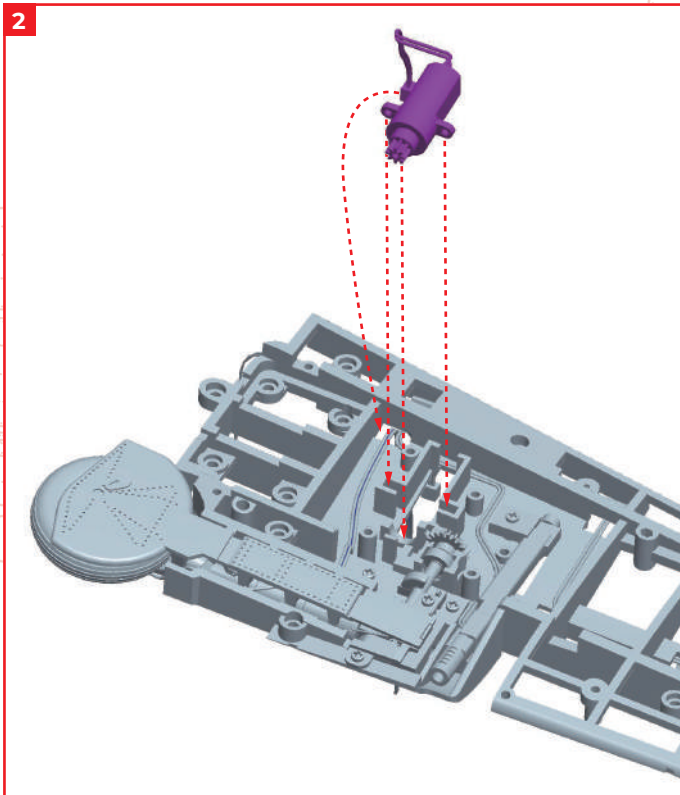

Fit the motor assembled in 1 into the right wing frame 044-01 assembled in stage 46. Pass the motor wire through the circled part.

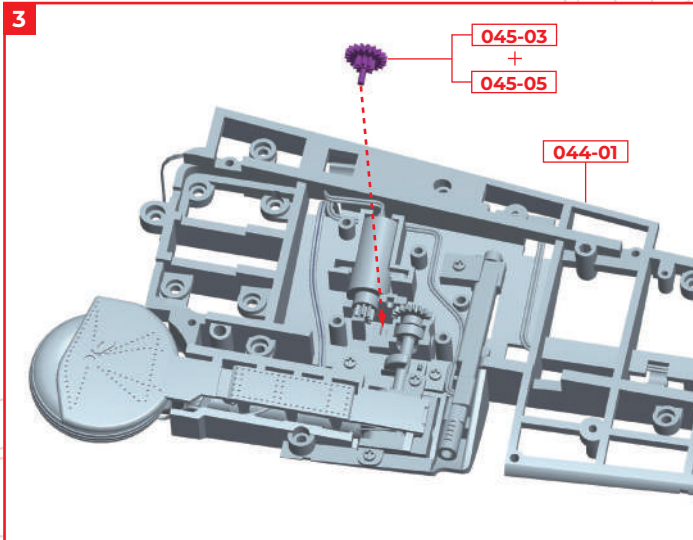

Fit the gear 045-03 and shaft 045-05 assembled in stage 45.

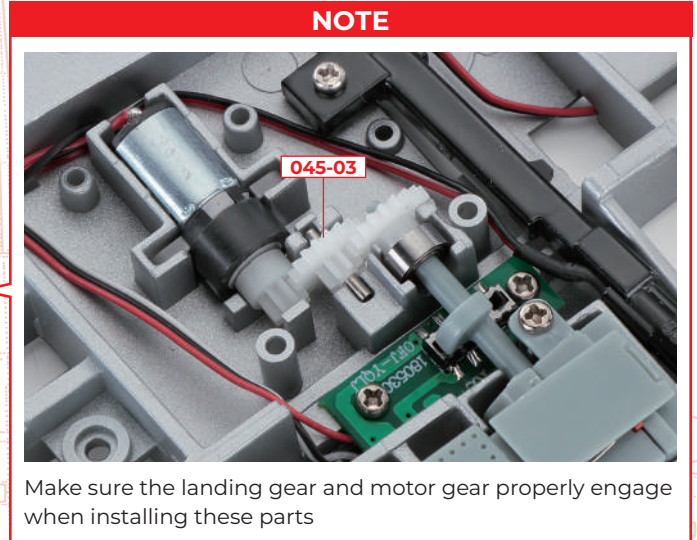

Make sure the landing gear and motor gear properly engage when installing these parts

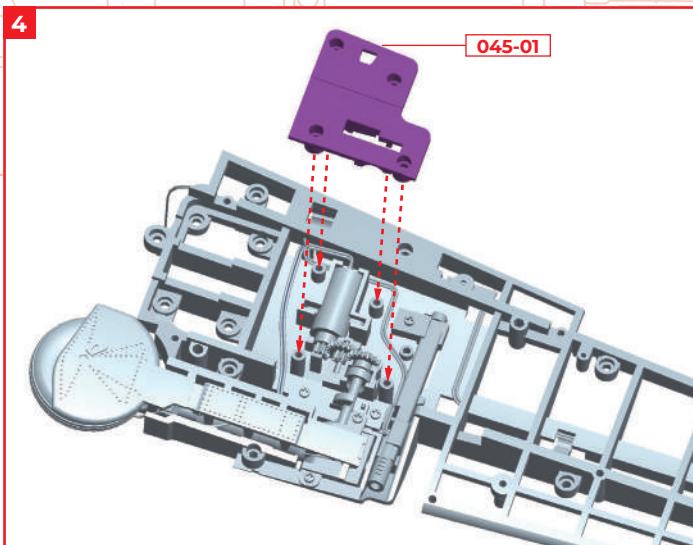

Fit the cover 045-01 that came with stage 45.

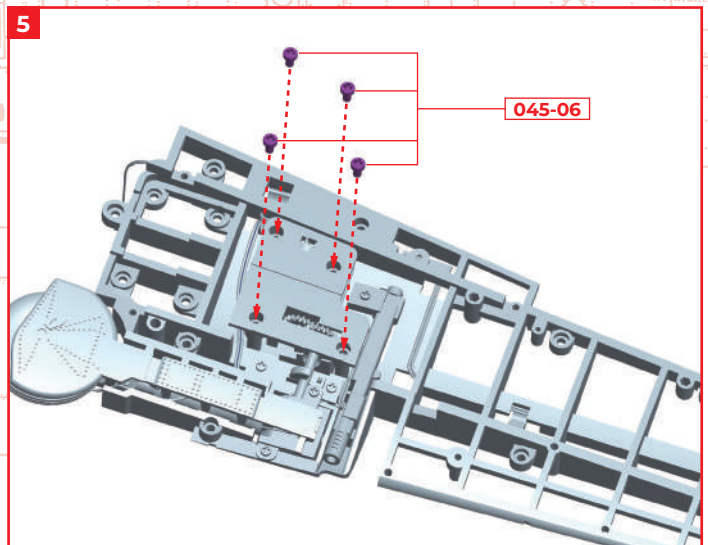

Fix the cover 045-01 with the 4 screws 045-06 that came with

STAGE COMPLETE

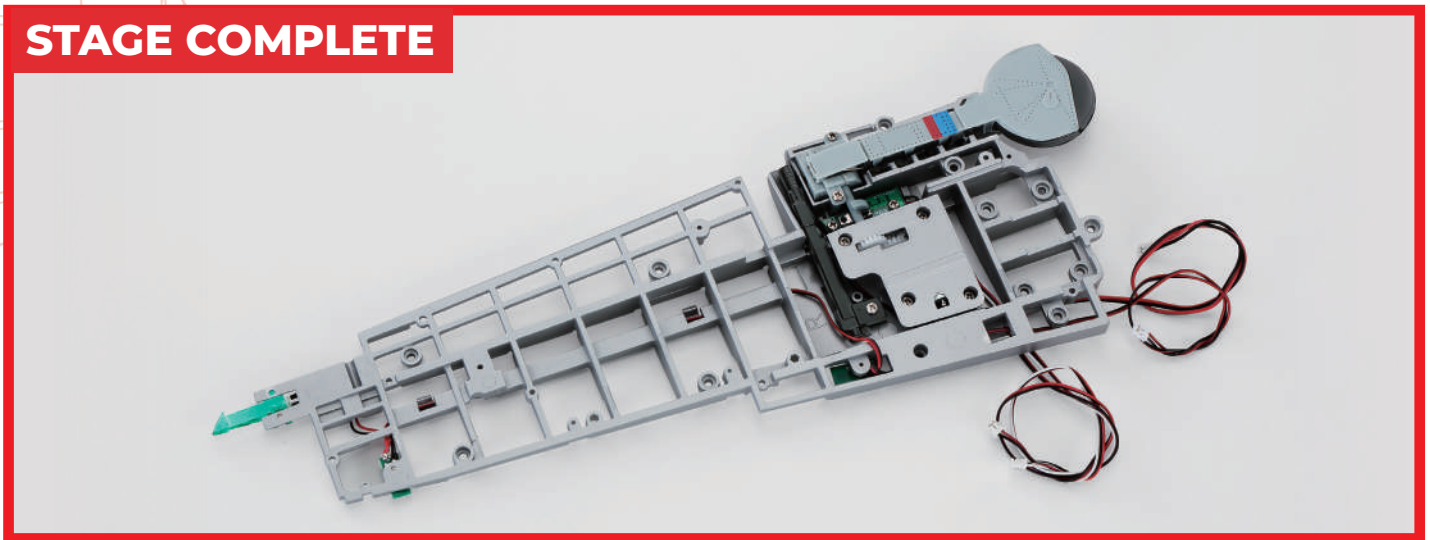

Stage 48: Installing the Right Aileron



Stage 48 Assembly

Aileron

In this stage we'll be installing the right aileron. Not inserting or fitting small parts properly or having them in a skewed position means the model won't work later.

STAGE 48 PARTS

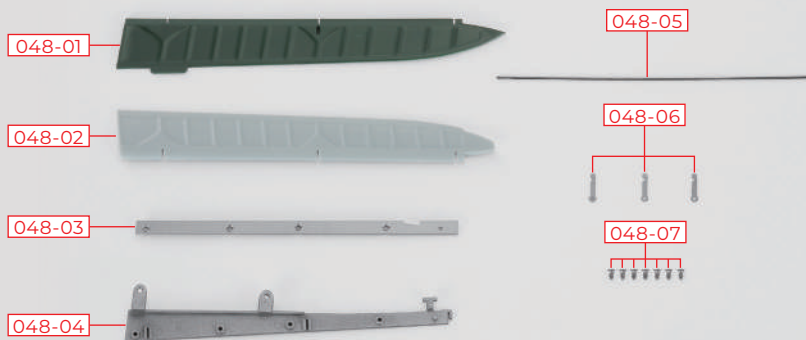

You will also need: screwdriver, tweezers, superglue.

PARTS LIST

	PART	No.	MATERIAL
<input type="checkbox"/>	048-01	1	ABS resin
<input type="checkbox"/>	048-02	1	ABS resin
<input type="checkbox"/>	048-03	1	ABS resin
<input type="checkbox"/>	048-04	1	ABS resin
<input type="checkbox"/>	048-05	1	Steel
<input type="checkbox"/>	048-06	3	Steel
<input type="checkbox"/>	048-07	7 (1 spare)	Steel

STEP 1

Assembling the aileron base (R)

← : Glue
 - - - : Don't Glue

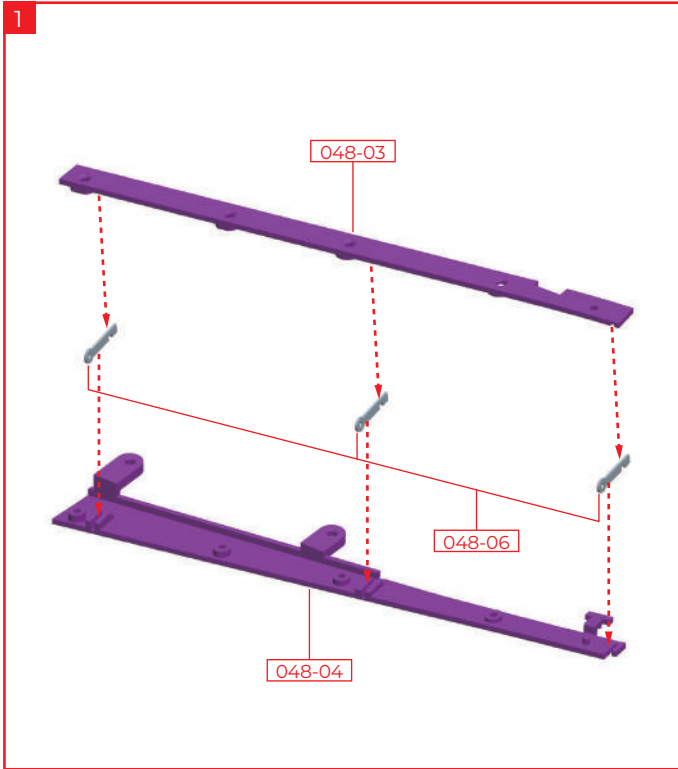

Insert the hinges 048-06 into the three grooves of the aileron base 048-04 with the notches facing down, and lower the fastener 048-03 on top.

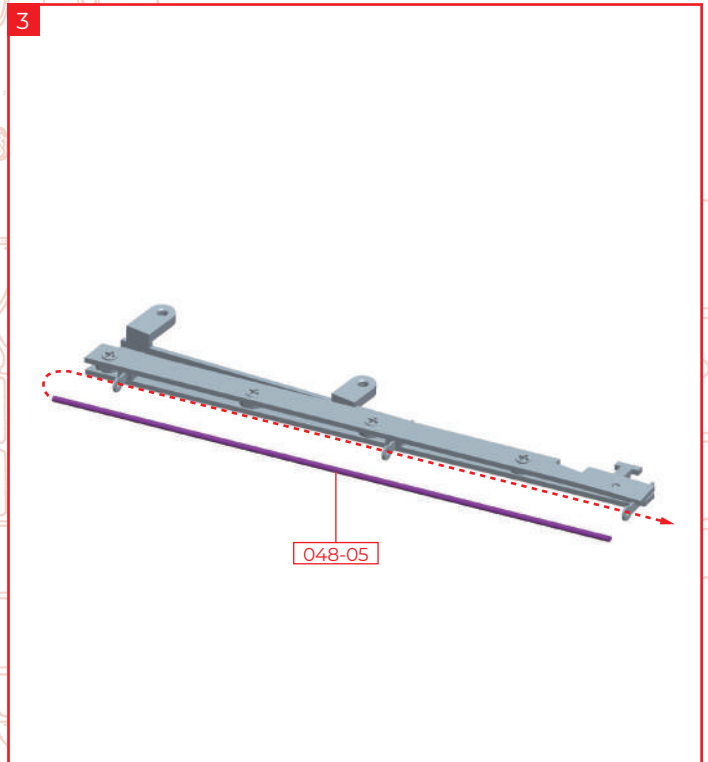
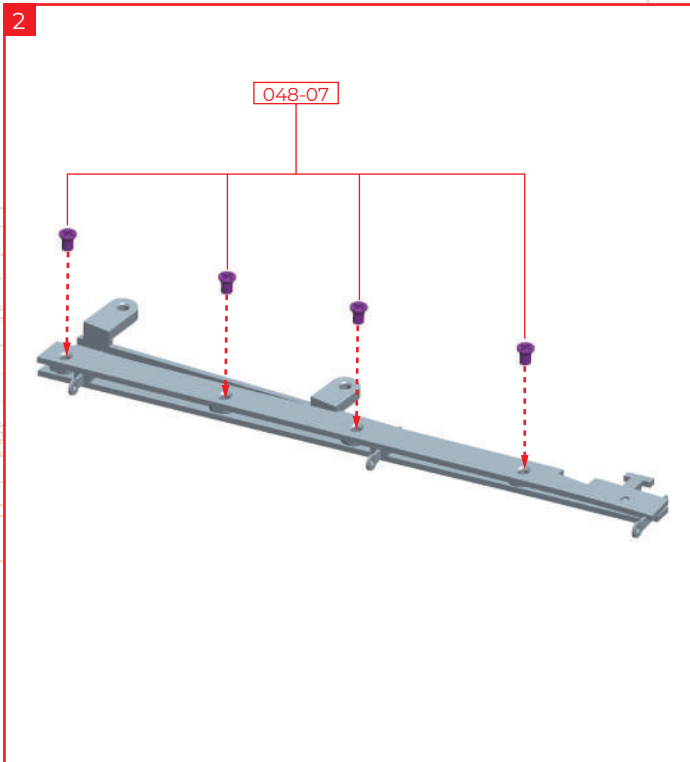

Fix the fastener 048-03 to the aileron base 048-04 with 4 x screws 048-07.

Pass shaft 048-05 through the holes in hinges 048-06.

STEP 2

Installing the right wing

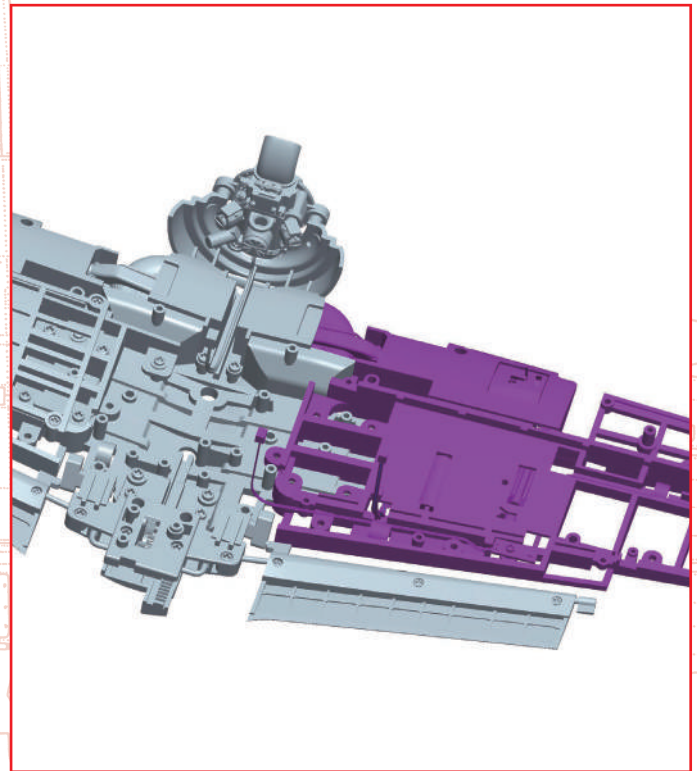
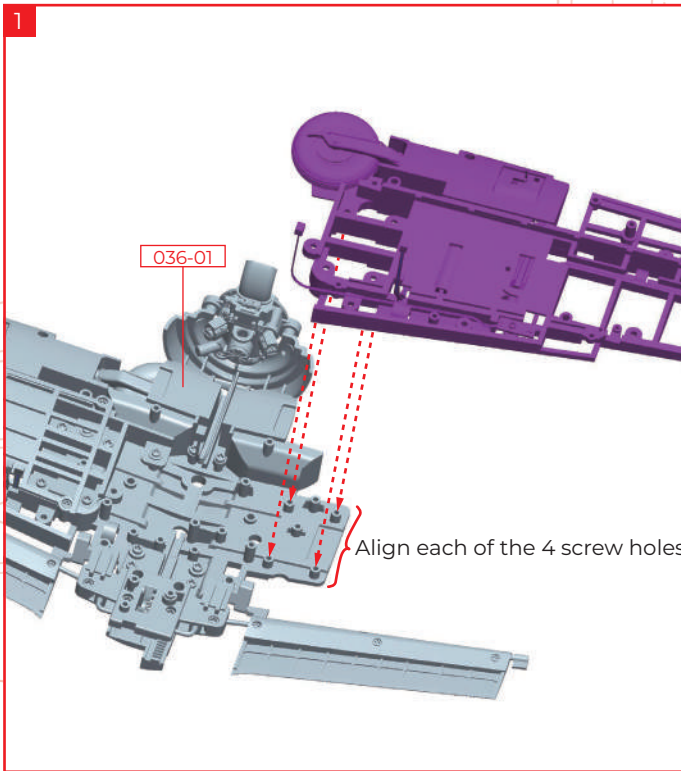

Fit the right wing assembled in stage 47 into the right side of the main wing base frame 036-01 of the body to which the left wing was attached in stage 40.

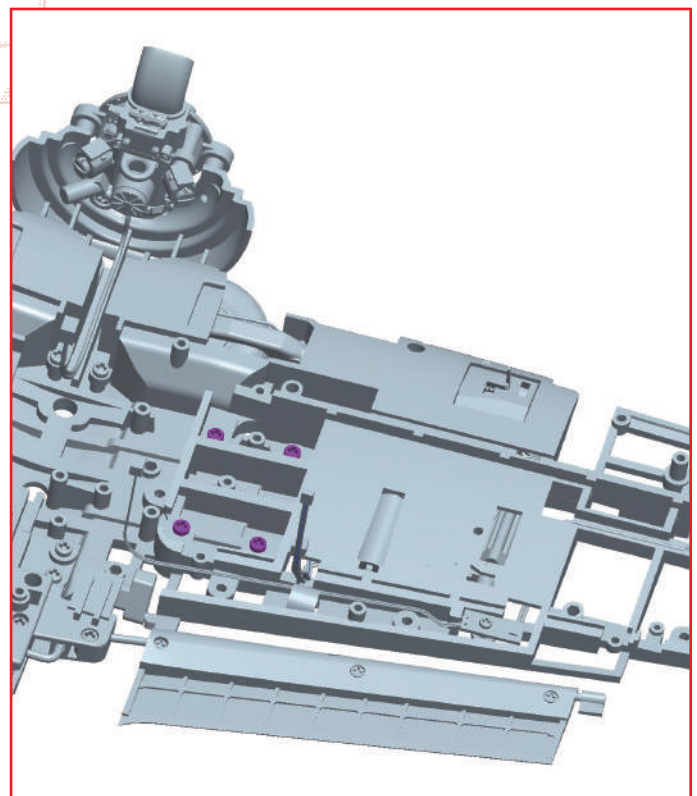
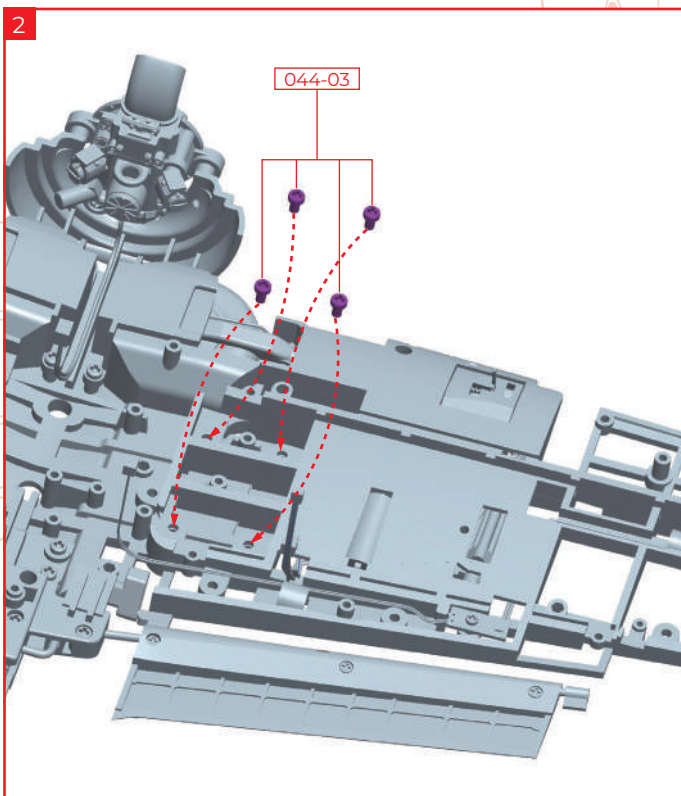

Fix the right wing with the 4 screws 044-03 that came with stage 44.

STEP 3

Installing the right aileron

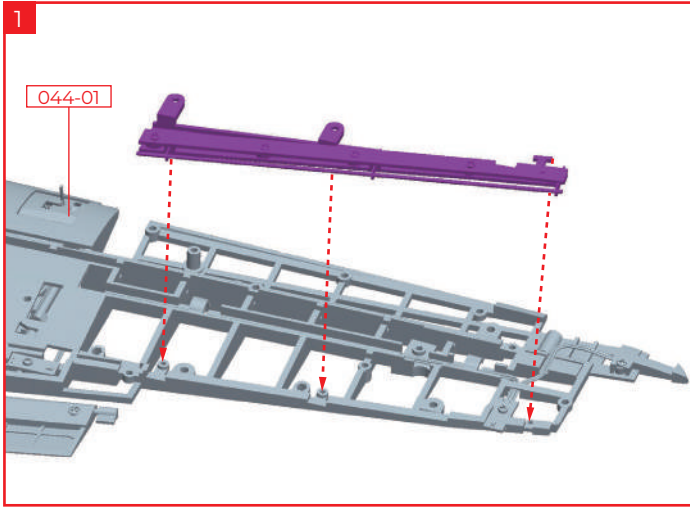

Fit the aileron base assembled in STEP 1 into the right wing frame **044-01**.

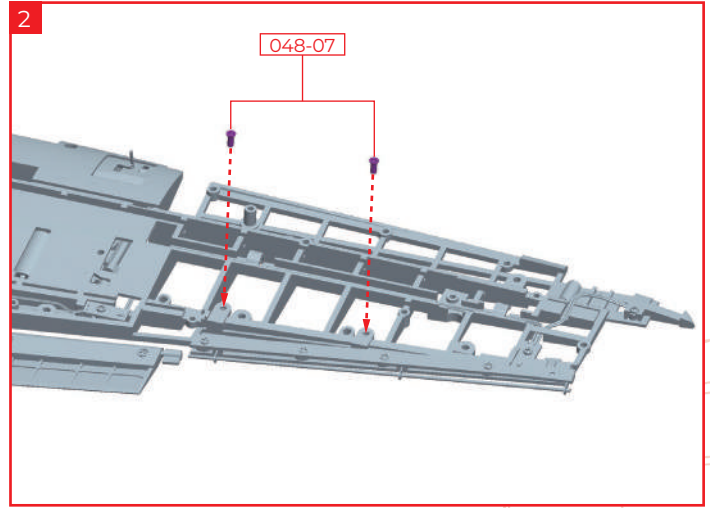

Fix the aileron base in place with 2 x screws **048-07**.

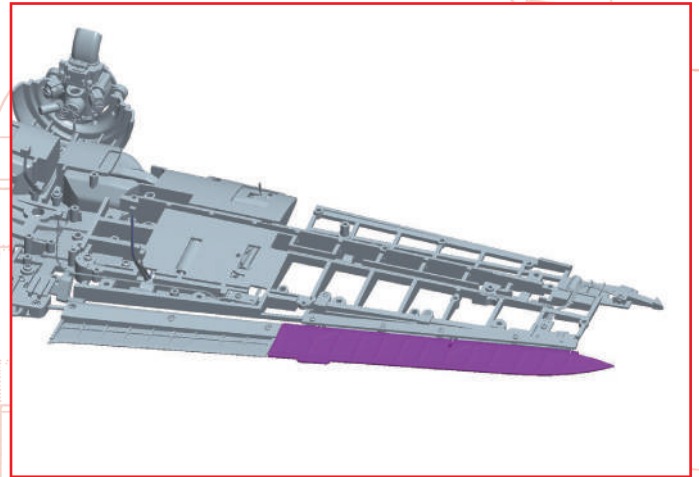
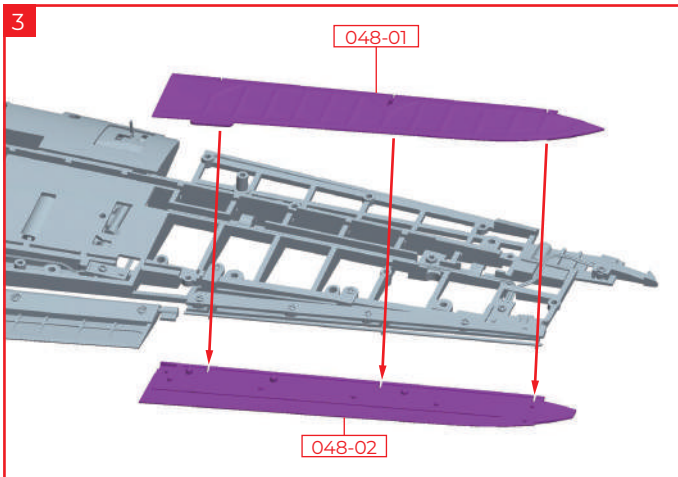

Apply a small amount of superglue to the 10 lugs on the aileron underside **048-02** (see stage 39 "STEP 2 Installing the aileron") and attach to the aileron base in 2. Place the shaft **048-05** and the hinges **048-06** in the grooves and then lower the upper surface of the aileron **048-01** on top, squeezing the glued lugs into the corresponding recesses to fix.

STAGE COMPLETE

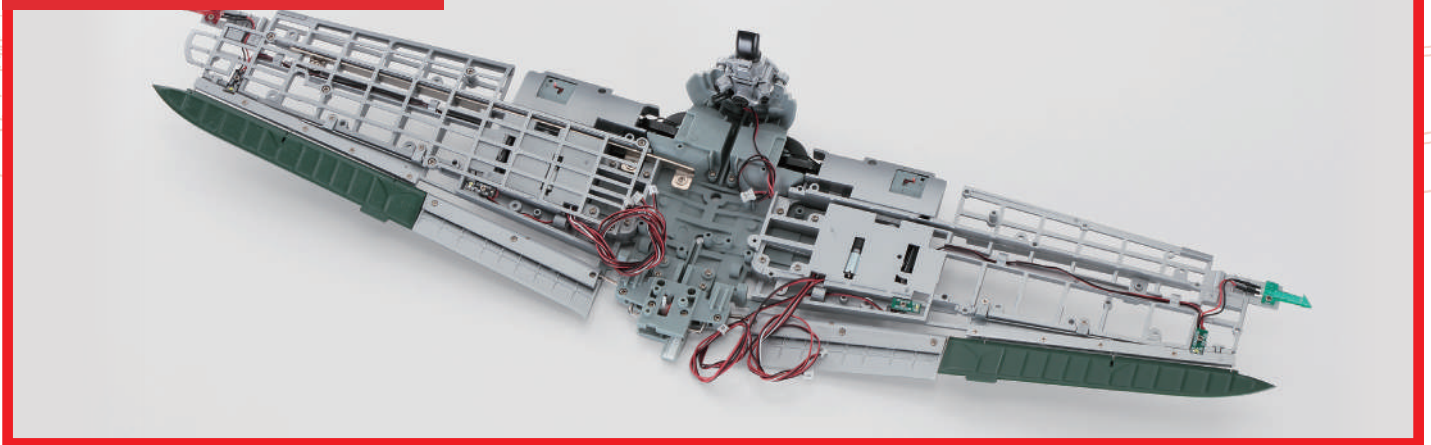

Stage 49: Installing Right Wing Support Fittings, the External Panel Frame and the Cockpit

In this stage we'll be installing support fittings for the left wing as well as the frame we'll attach the external panels to later. We'll also attach the cockpit to the wing main frames.

Stage 49 Assembly

Metal Support Bar, External Panel Frame & Cockpit

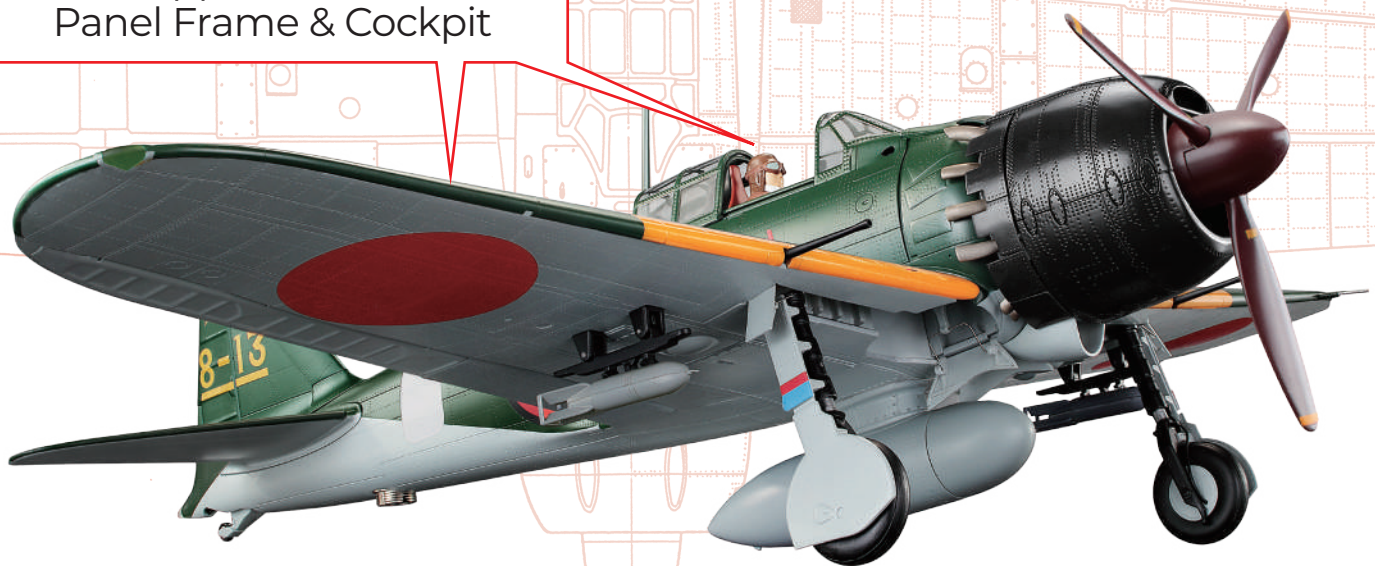

STAGE 49 PARTS

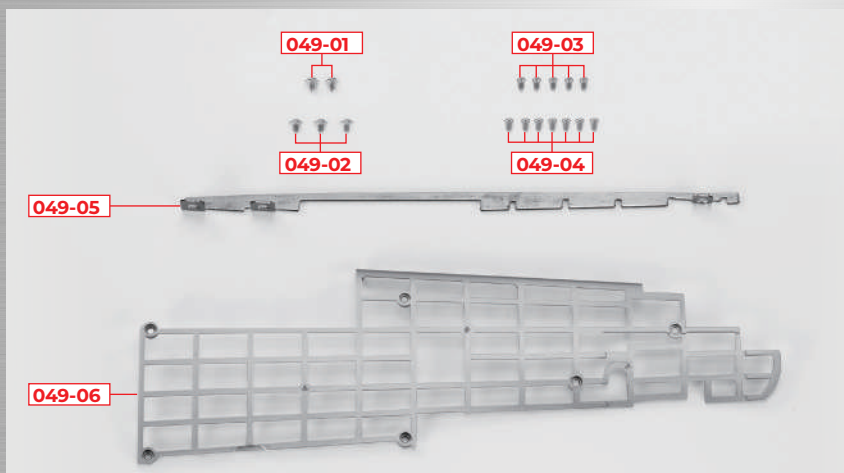

You will also need: screwdriver, tweezers.

PARTS LIST

	PART	No.	MATERIAL
<input type="checkbox"/>	049-01	2 (1 spare)	Steel
<input type="checkbox"/>	049-02	3 (1 spare)	Steel
<input type="checkbox"/>	049-03	5 (1 spare)	Steel
<input type="checkbox"/>	049-04	7 (1 spare)	Steel
<input type="checkbox"/>	049-05	1	Steel
<input type="checkbox"/>	049-06	1	ABS resin

STEP 1

Installing the right wing support fittings

← : Glue
 - - - : Don't Glue

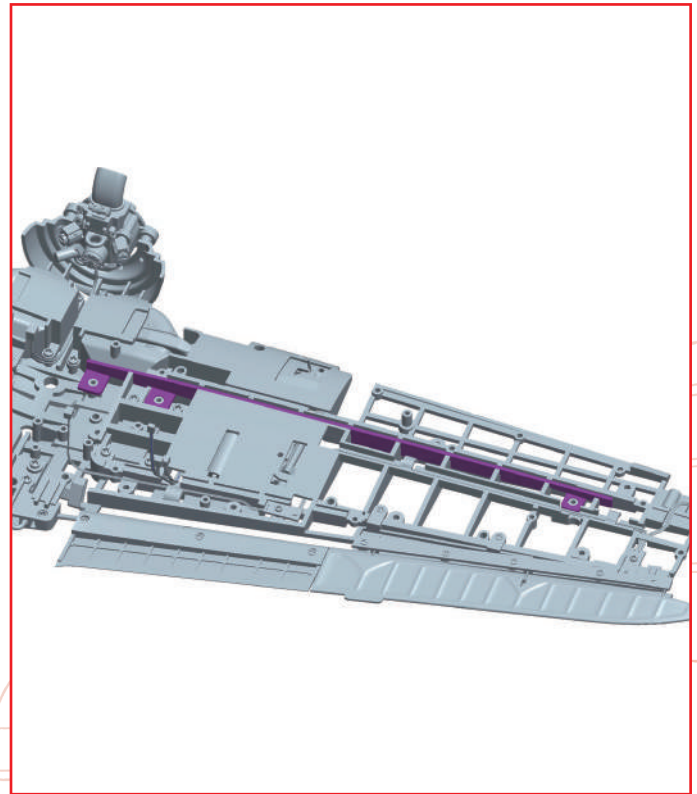
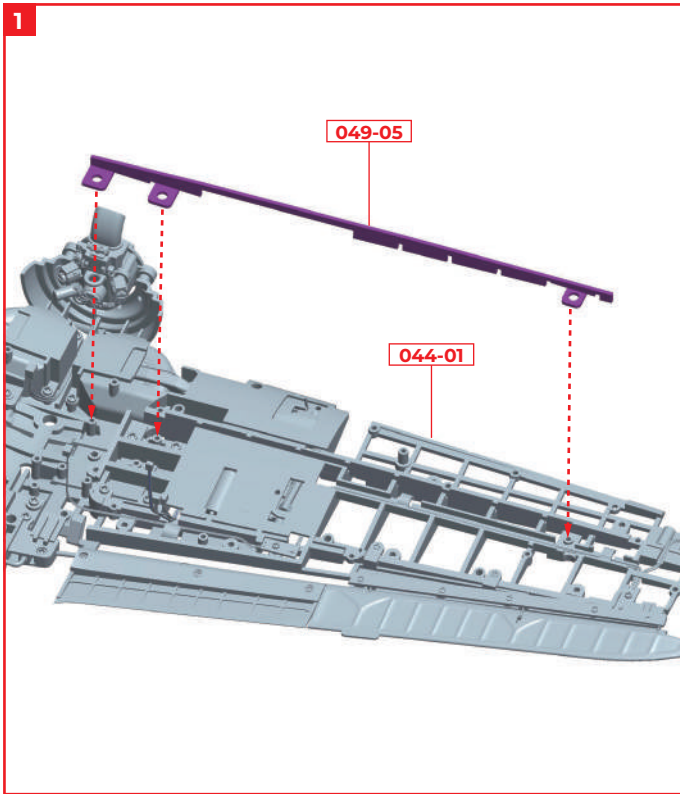

Fit the metal support bar 049-05 into the right wing frame 044-01 assembled in stage 48.

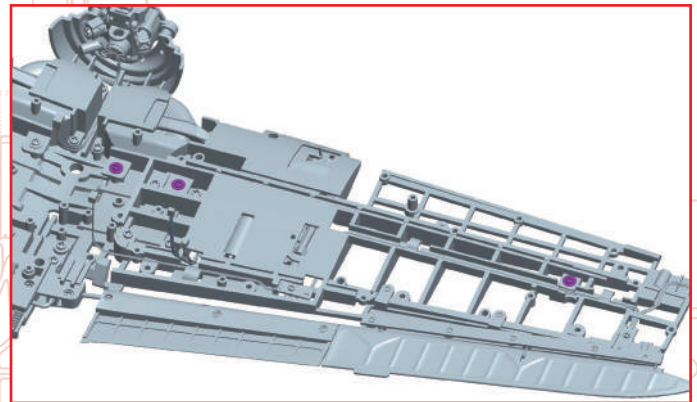
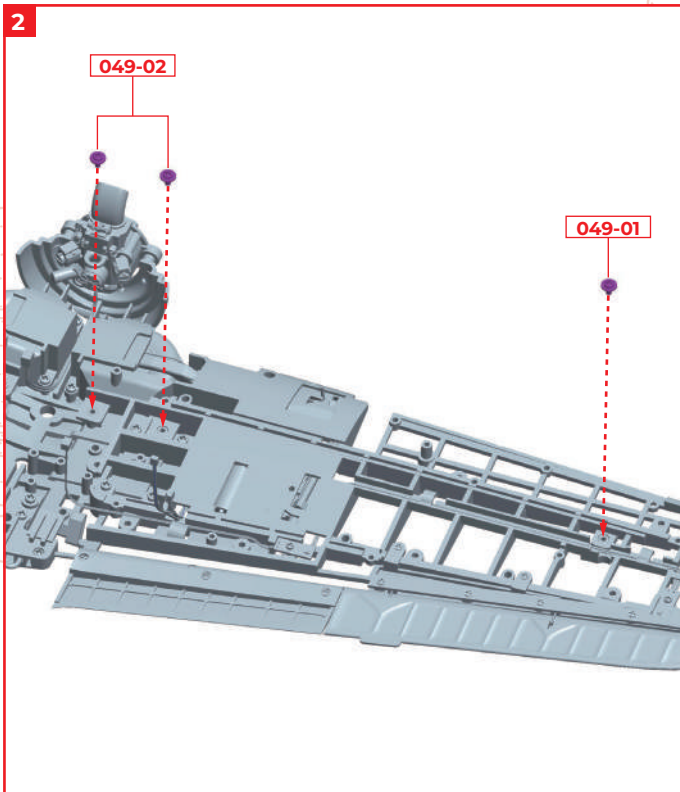

Fix in place with 1 x screw 049-01 and 2 x screws 049-02.

NOTE



There are four types of screws. Be careful not to make a mistake.

STEP 2

Installing the external panel frame

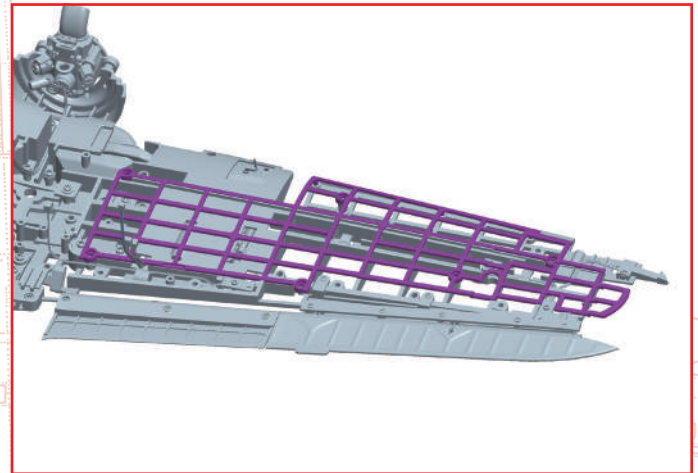
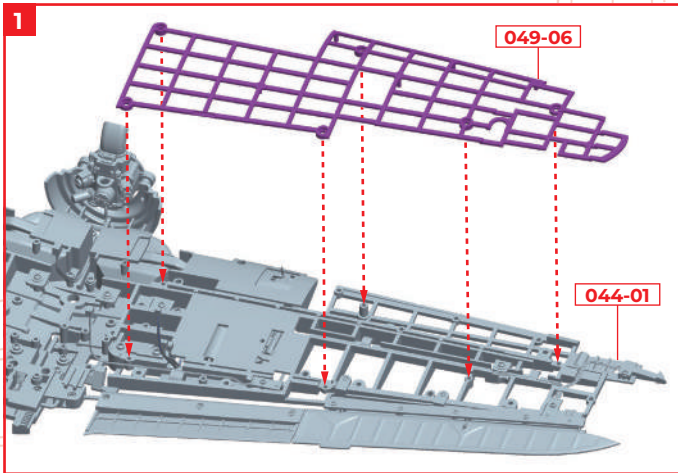

Cover the right main wing frame **044-01** with the external panel frame **049-06**. Align the 6 screw holes and 6 pins of **049-06** with the corresponding parts of the wing frame.

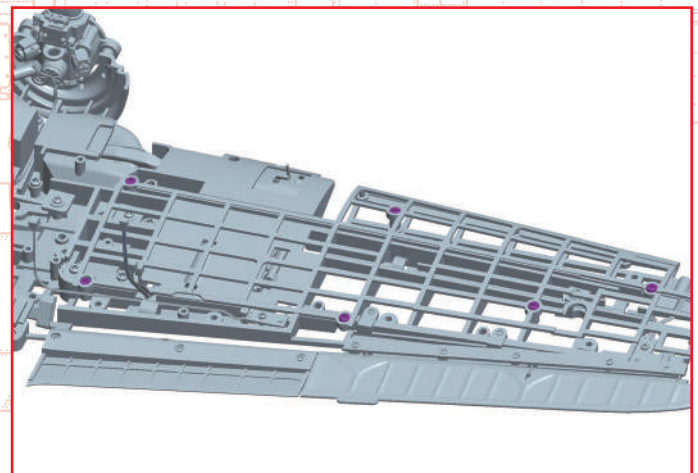
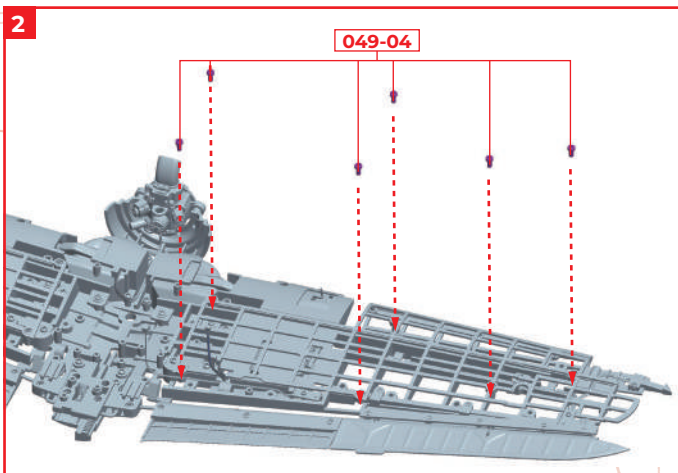

Fix in place with 4 x screws **049-04**.

STEP 3

Installing the cockpit

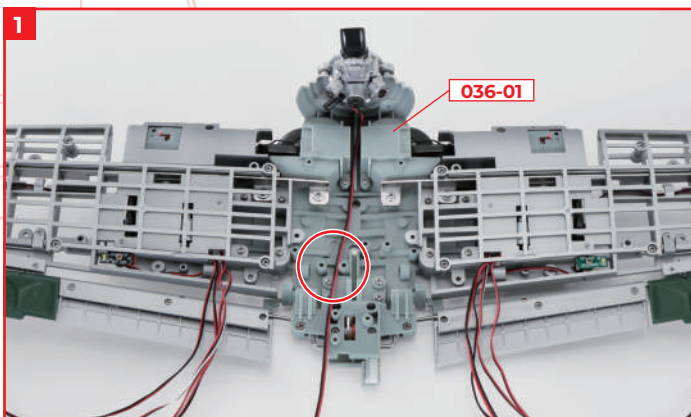

Extend the wire of connector **015-06** from the carburettor and supercharger unit attached to the wing base frame **036-01** to the rear and pass it between the two cylinders on the left side of the wing base frame **036-01**.

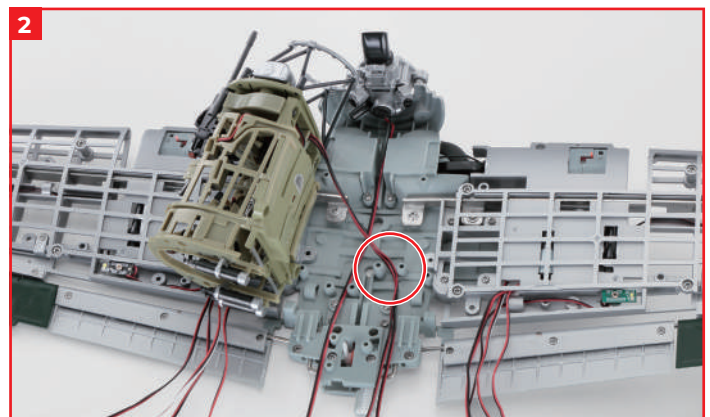

Extend the wire of the machine gun magazine circuit board **020-01** from the cockpit assembled in stage 27 backward and pass it between the two cylinders on the right side of the main wing base frame **036-01**.

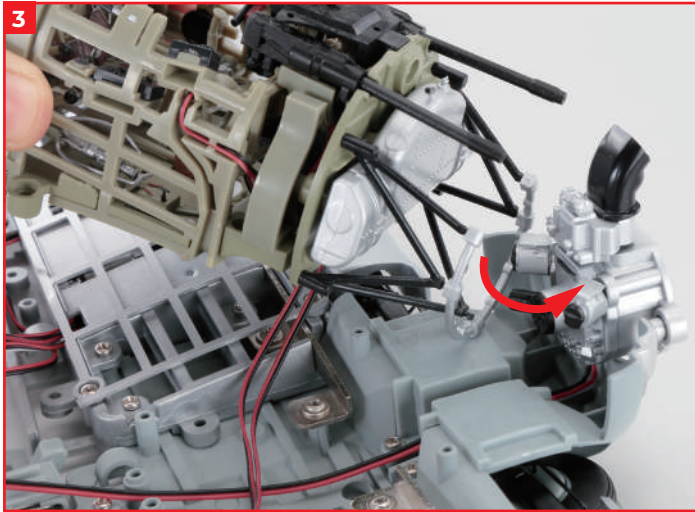

NOTE

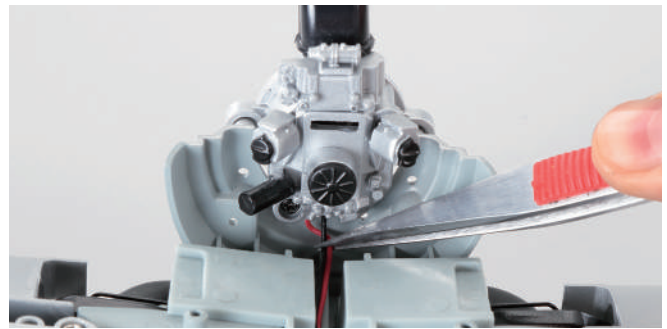

If there is a gap between the main wing base frame and the silver frame at the tip of the cockpit, the wire of connector 015-06 is caught, so insert it by pressing it against the front partition wall with tweezers.

Insert the cockpit so that the carburettor and supercharger of the main wing base frame 036-01 can be inserted into the silver frame at the tip of the cockpit. The black cylindrical part on the left back of the carburettor and supercharger gets in the way, so it's a good idea to insert it diagonally from the left back.

NOTE

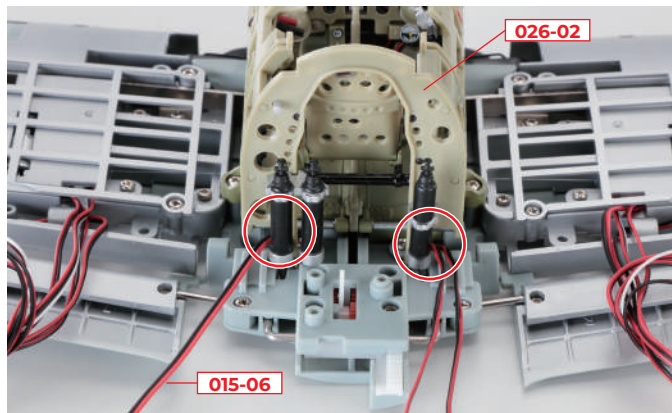

The wires for connector 015-06 and machine gun magazine circuit board 020-01 should pass outside the cockpit rear bulkhead 026-02.

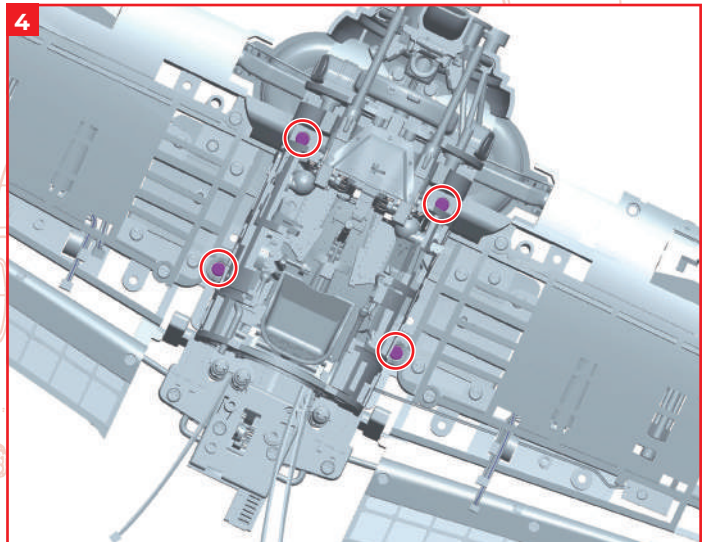

Fix the cockpit in place with 4 x screws 049-03.

STAGE COMPLETE



Stage 50: Assembling the Tail Gear Retraction Mechanism



Stage 50 Assembly

Tail Gear Retraction Mechanism

The A6M Zero Type 52 was designed such that when in flight both the main and rear landing gear would retract into the body of the plane, coming back out for landings. In this stage we'll assemble the gearbox for the tail gear retraction mechanism, so make sure the gears are facing in the right direction when working through those steps.

STAGE 50 PARTS

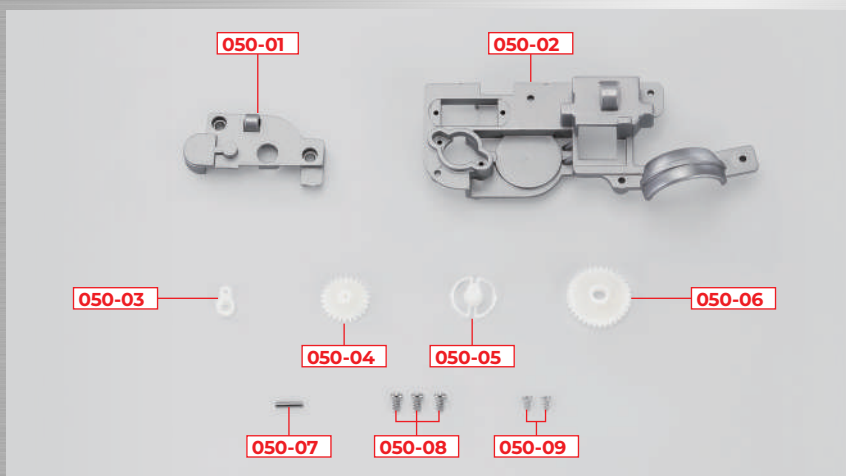

You will also need: screwdriver, tweezers.

PARTS LIST

	PART	No.	MATERIAL
<input type="checkbox"/>	050-01	1	ABS resin
<input type="checkbox"/>	050-02	1	ABS resin
<input type="checkbox"/>	050-03	1	Plastic
<input type="checkbox"/>	050-04	1	Plastic
<input type="checkbox"/>	050-05	1	Plastic
<input type="checkbox"/>	050-06	1	Plastic
<input type="checkbox"/>	050-07	1	Steel
<input type="checkbox"/>	050-08	3 (1 spare)	Steel
<input type="checkbox"/>	050-09	2 (1 spare)	Steel

STEP 1

Inserting the gears

← : Glue
 - - - : Don't Glue

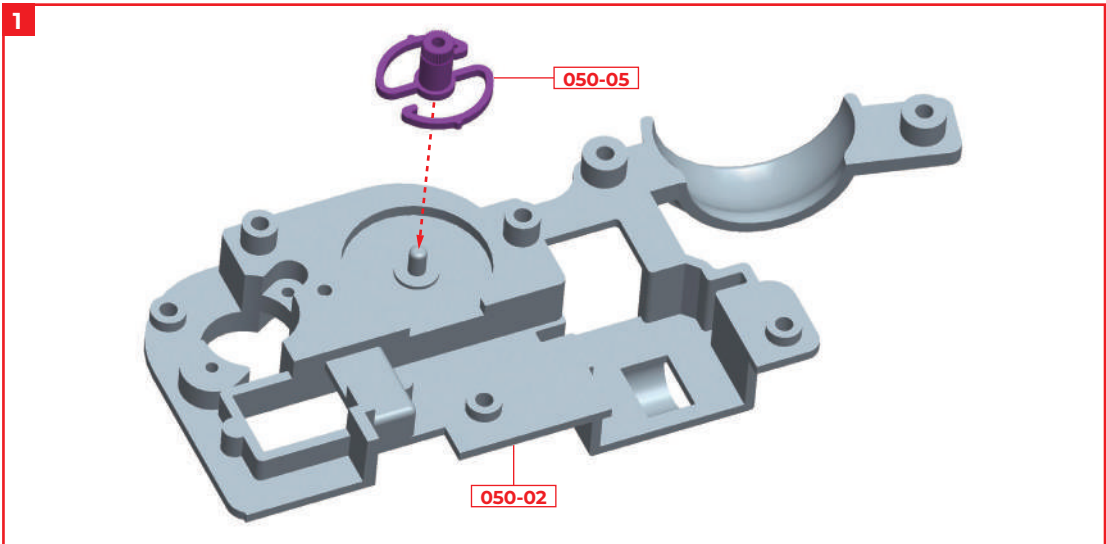

Fit the clutch 050-05 into the gearbox 050-02.

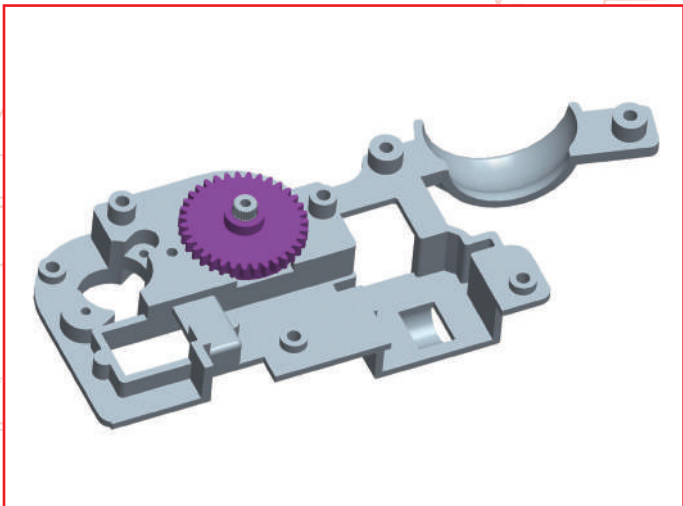
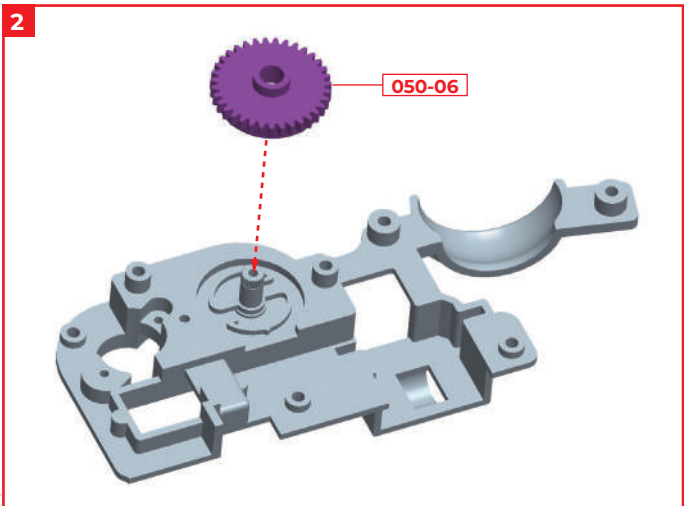

Fit the gear 050-06 into the clutch 050-05 installed in 1.

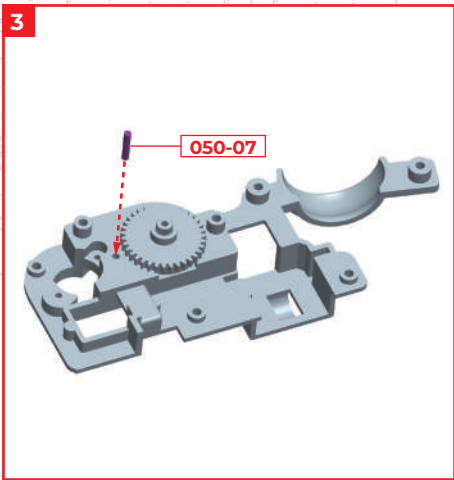

Insert the shaft 050-07 into the gearbox 050-02.

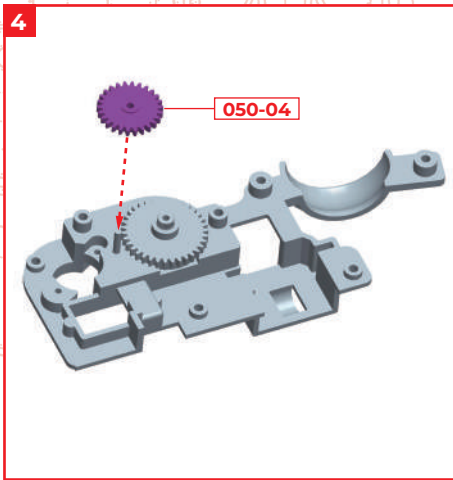

Fit the gear 050-04 into the shaft 050-07 attached in 3.

NOTE

If you make a mistake on the front and back of the gear, it will not operate normally. Make sure they are combined as shown in the picture.

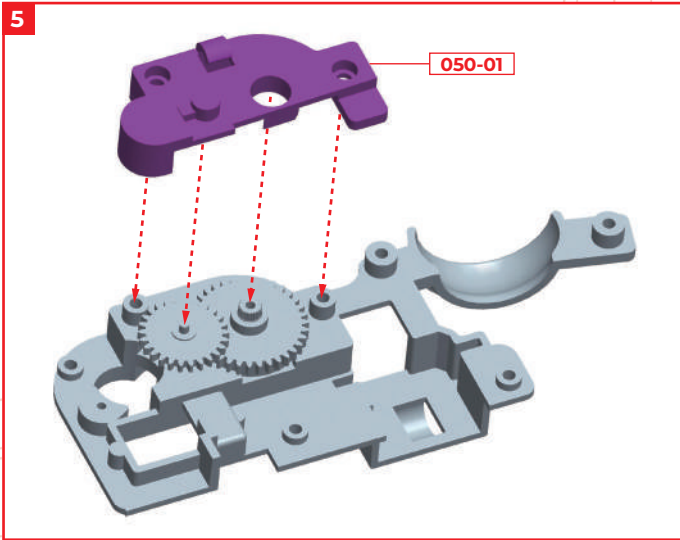

Cover the gearbox 050-02 with the gear cover 050-01.

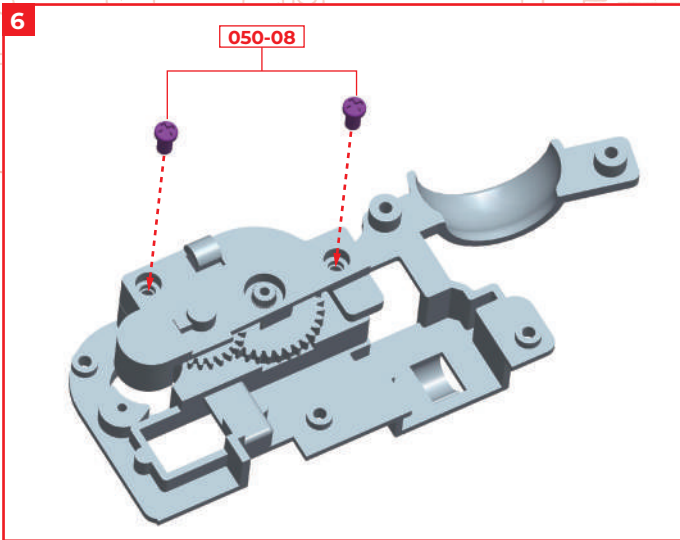
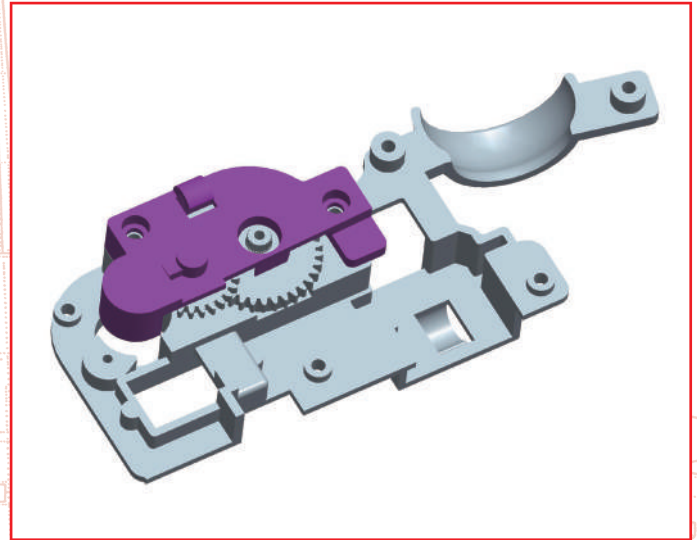

Secure the gear cover 050-01 with 2 x screws 050-08.

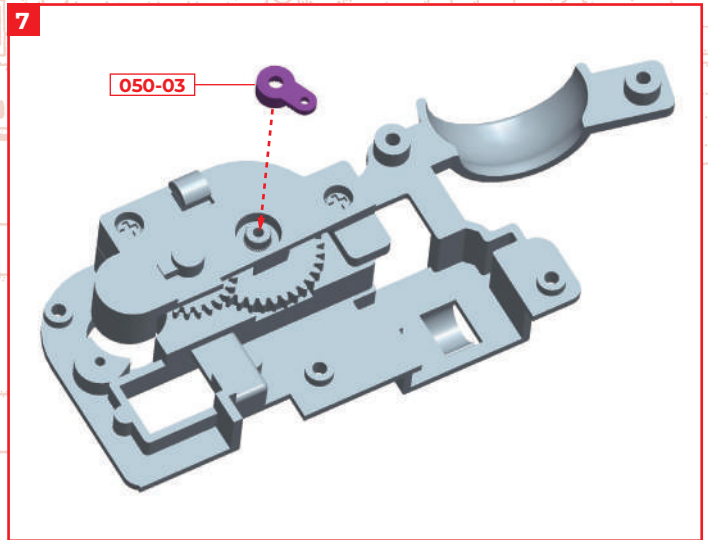

Fit the arm 050-03 onto the shaft of the clutch 050-05.

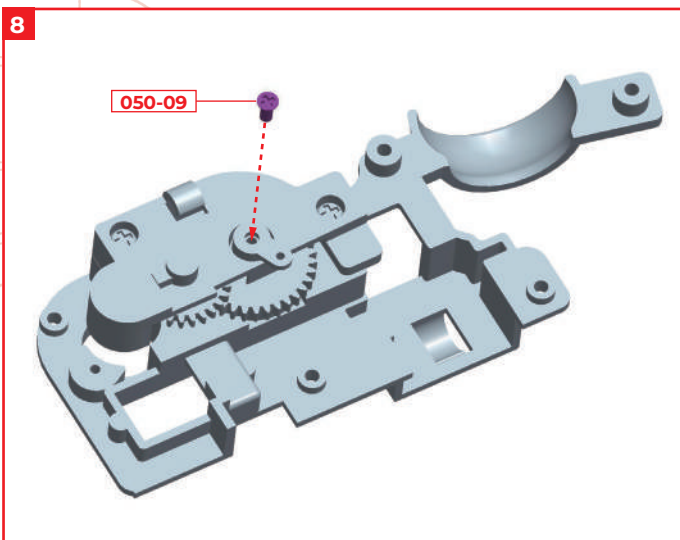

Fix the arm 050-03 with 1 x screw 050-09.

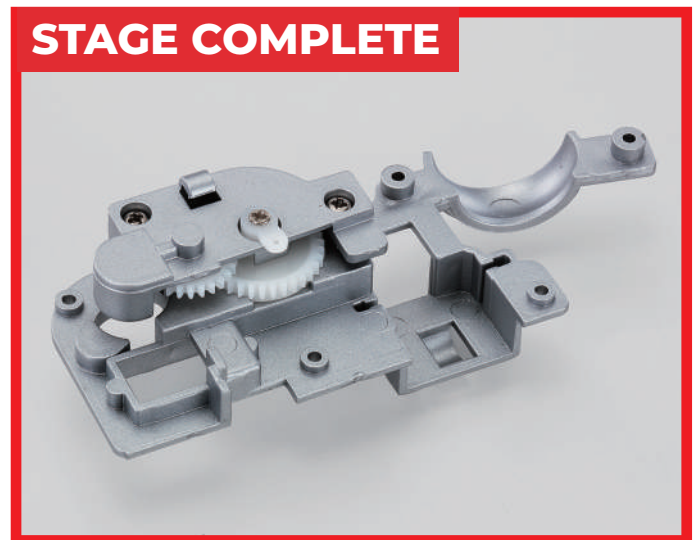

Stage 51: Assembling the Tail Gear Retraction Mechanism (2)



Stage 51 Assembly

Elevator Servomotor

In this stage we'll place the motor in the gearbox we assembled last time during stage 50. Make sure the gearbox and motor gears properly mesh.

STAGE 51 PARTS

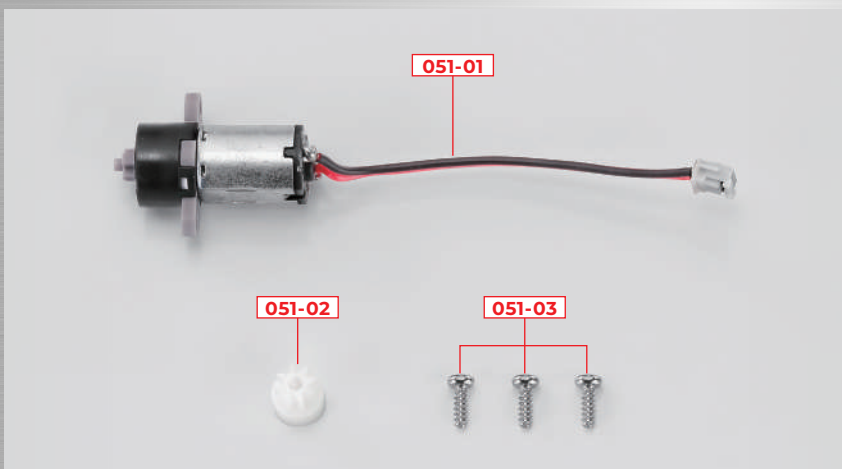

You will also need: screwdriver, tweezers.

PARTS LIST

	PART	No.	MATERIAL
<input type="checkbox"/>	051-01	1	Motor
<input type="checkbox"/>	051-02	1	Plastic
<input type="checkbox"/>	051-03	3 (1 spare)	Steel

STEP 1

Installing the motor

← : Glue
- - - : Don't Glue

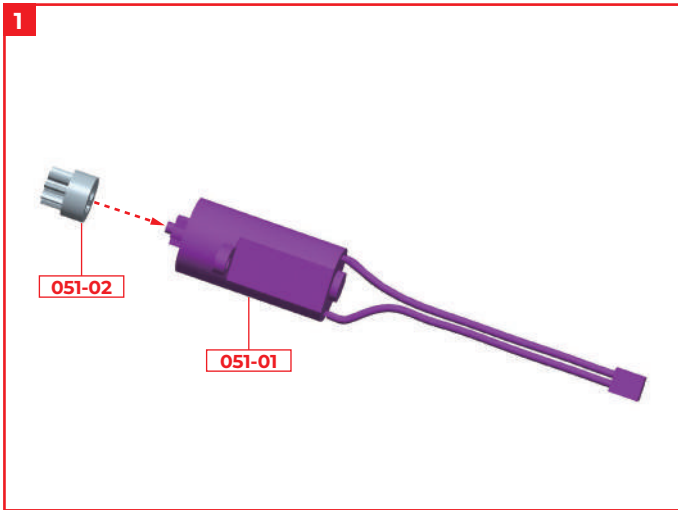

Fit gear 051-02 into motor 051-01.

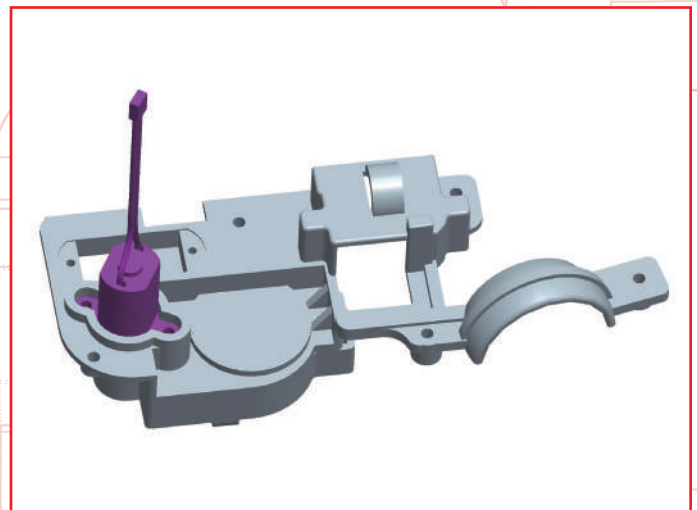
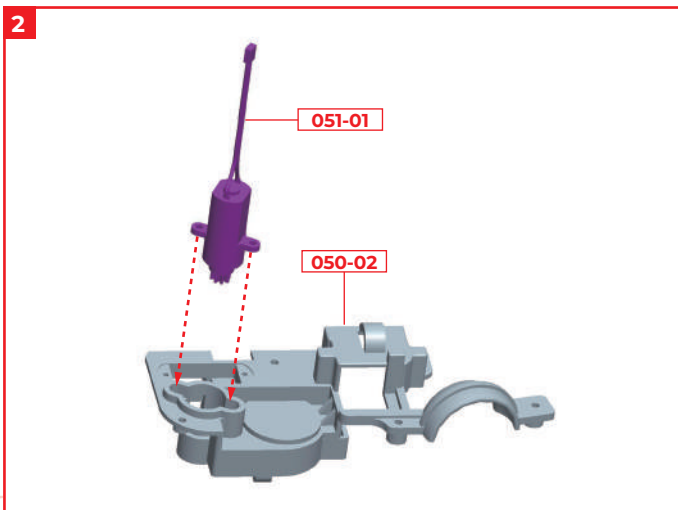

Fit the motor 051-01 from the back of the gearbox 050-02 assembled in stage 50.

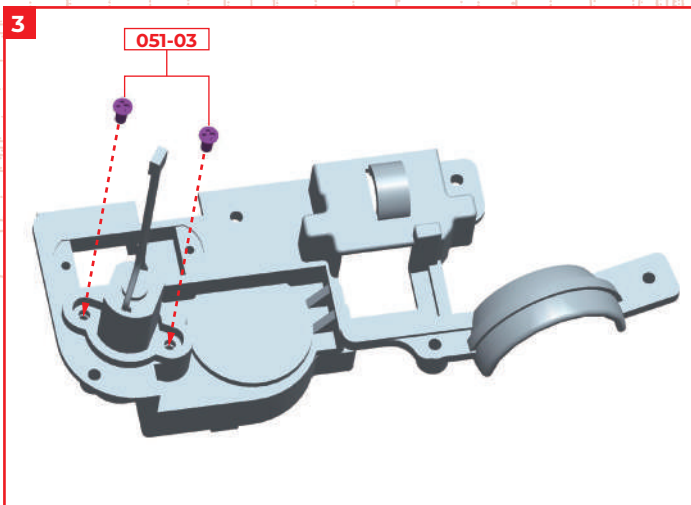

Fix the motor in place with 2 x screws 051-03.

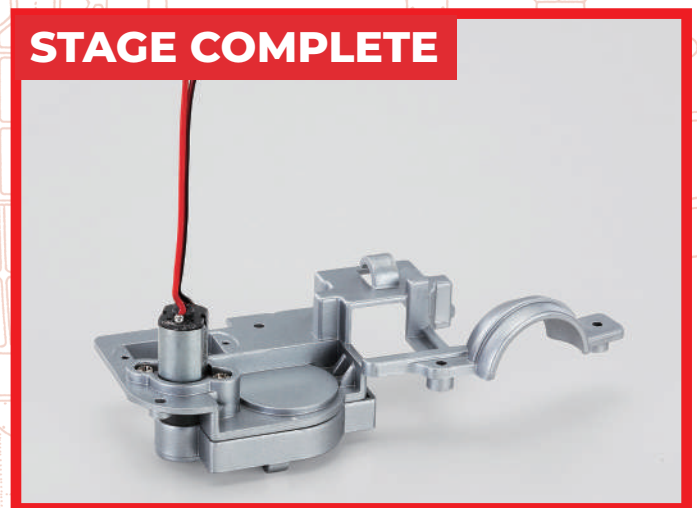

Stage 52: Checking the Elevator Servomotor



Stage 52 Assembly
 Elevator Servomotor

In this stage we'll prepare the servomotor. Make sure you've got the correct number of screws and that these are the right shape, ready for use in the next stage.

STAGE 52 PARTS

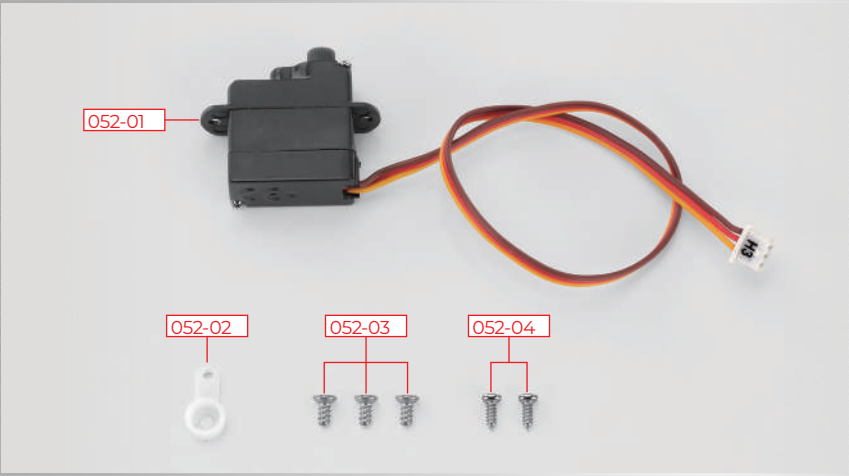

PARTS LIST

	PART	No.	MATERIAL
<input type="checkbox"/>	052-01	1	Servomotor
<input type="checkbox"/>	052-02	1	Plastic
<input type="checkbox"/>	052-03	3 (1 spare)	Steel
<input type="checkbox"/>	052-04	2 (1 spare)	Steel

There is no assembly in this stage. Unpack your parts and move straight on to stage 53.

Stage 53: Assembling the Tail Gear Retraction Mechanism (3)

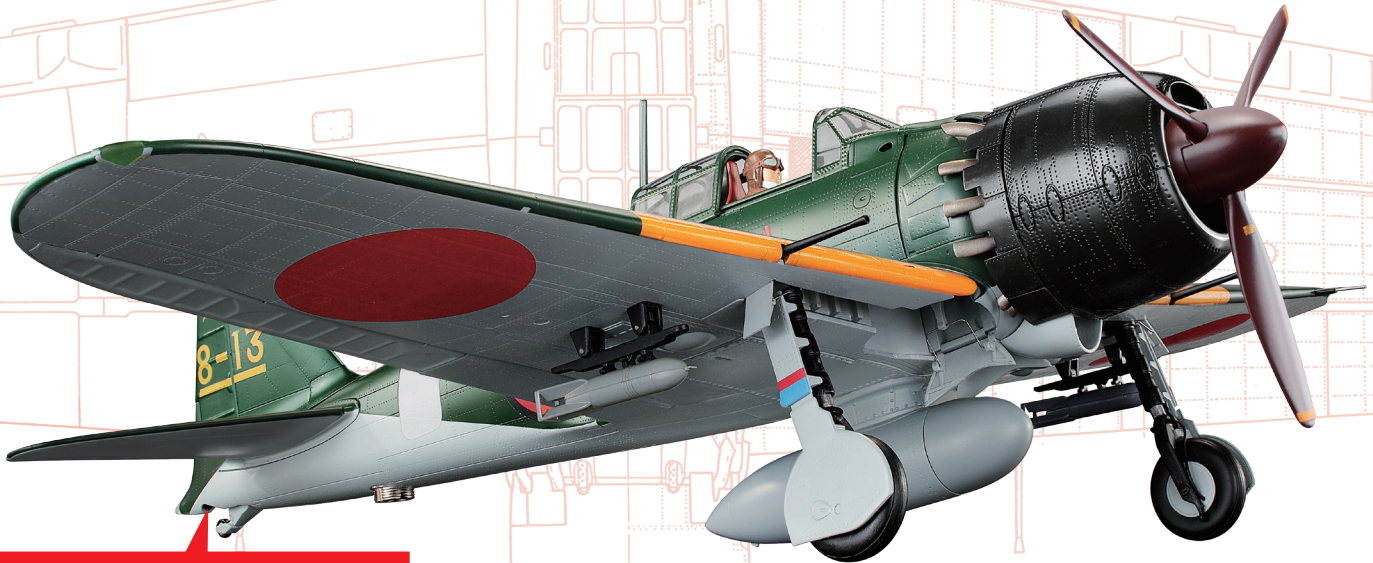

Stage 53 Assembly

Tail Gear Retraction Mechanism

In this stage we'll carry on assembling the tail gear retraction mechanism.

STAGE 53 PARTS

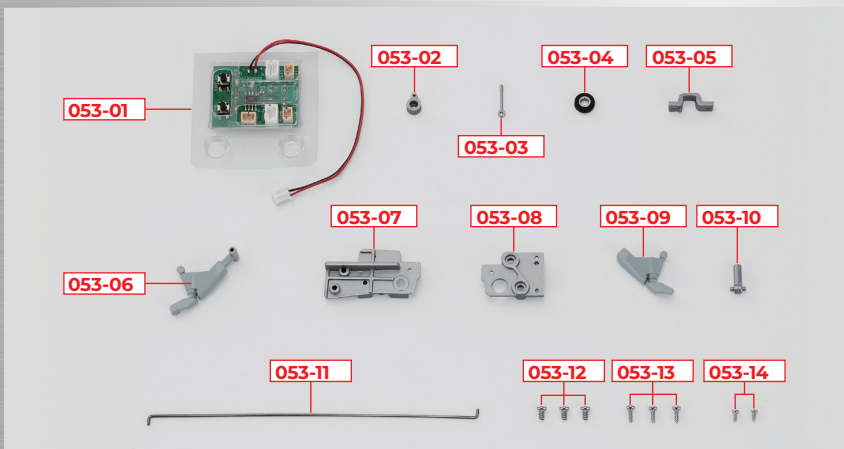

You will also need: screwdriver, tweezers, 3 x AAA batteries.
 *053-01 & 053-11 will be used in a later stage, so keep in a safe place until required.

PARTS LIST

	PART	No.	MATERIAL
<input type="checkbox"/>	053-01	1	Tester
<input type="checkbox"/>	053-02	1	ABS resin
<input type="checkbox"/>	053-03	1	ABS resin
<input type="checkbox"/>	053-04	1	ABS resin
<input type="checkbox"/>	053-05	1	ABS resin
<input type="checkbox"/>	053-06	1	Die-cast
<input type="checkbox"/>	053-07	1	ABS resin
<input type="checkbox"/>	053-08	1	ABS resin
<input type="checkbox"/>	053-09	1	Die-cast
<input type="checkbox"/>	053-10	1	ABS resin
<input type="checkbox"/>	053-11	1	Steel
<input type="checkbox"/>	053-12	3 (1 spare)	Steel
<input type="checkbox"/>	053-13	3 (1 spare)	Steel
<input type="checkbox"/>	053-14	2 (1 spare)	Steel

STEP 1

Tail gear assembly

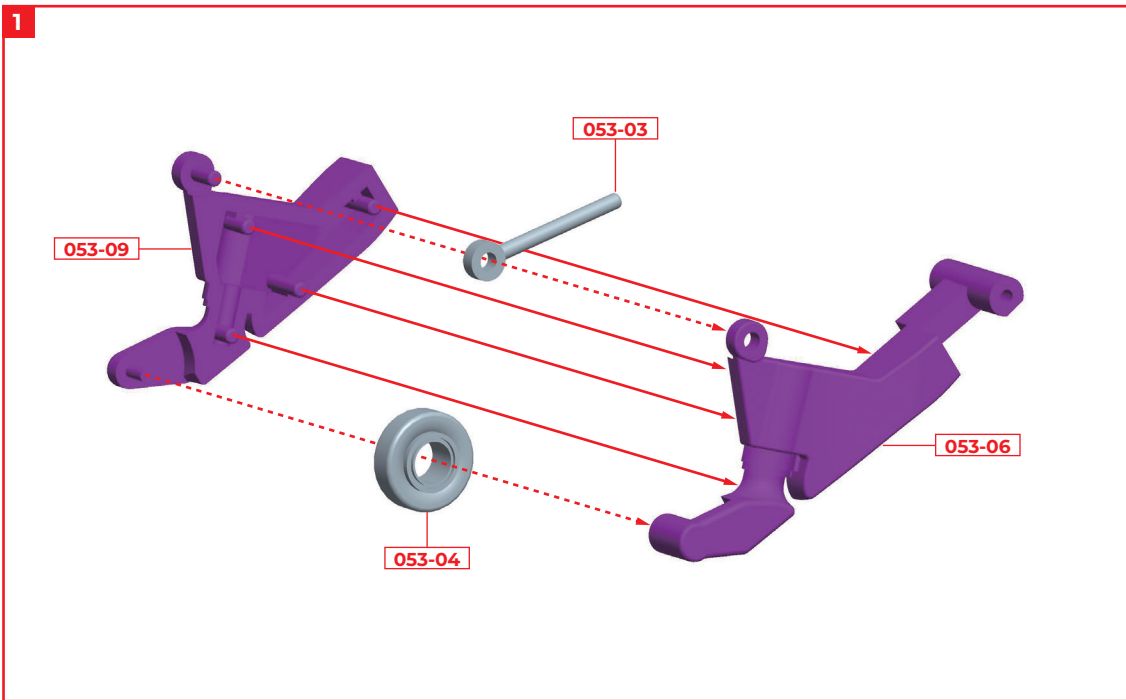

Fit the tyre 053-04 into the tail gear support column (R) 053-06, and fit the piston rod 053-03 into the tail gear support column (L) 053-09. Glue the left and right tail gear struts 053-06 and 053-09 with superglue. Tyre 053-04 and piston rod 053-03 are movable, so be careful not to glue them together.

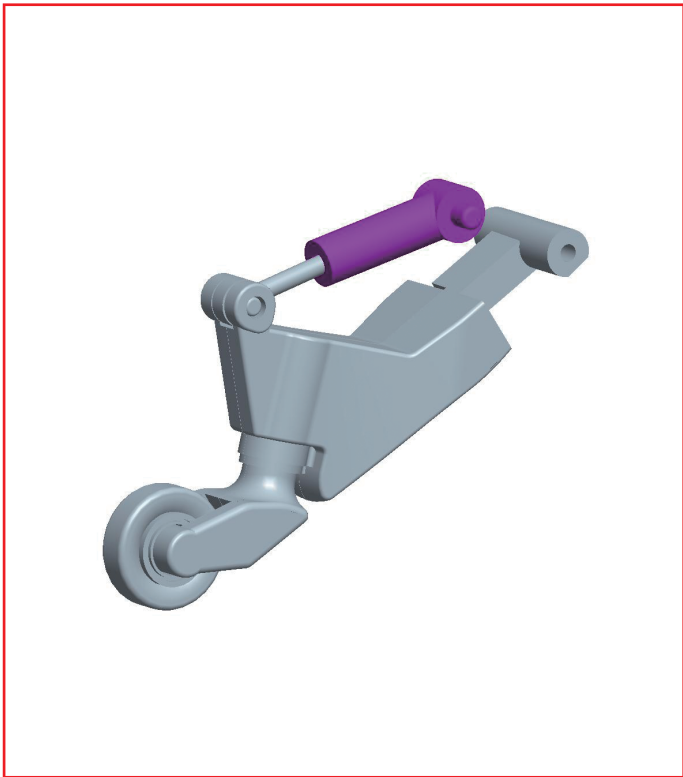
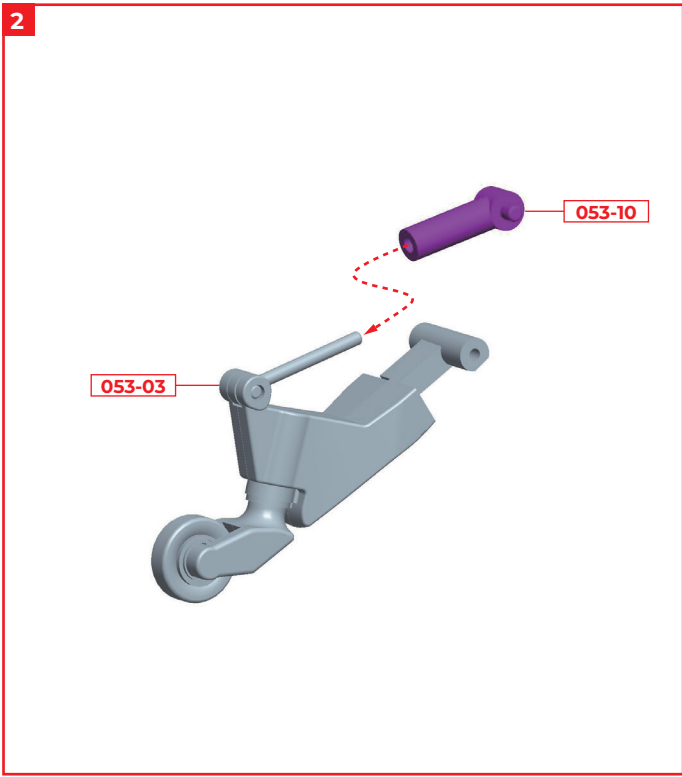

Fit the cylinder tube 053-10 into the piston rod 053-03. Do not glue.

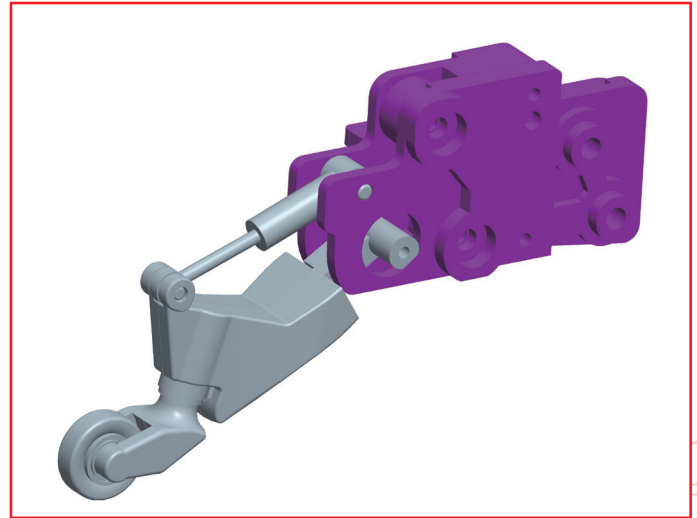
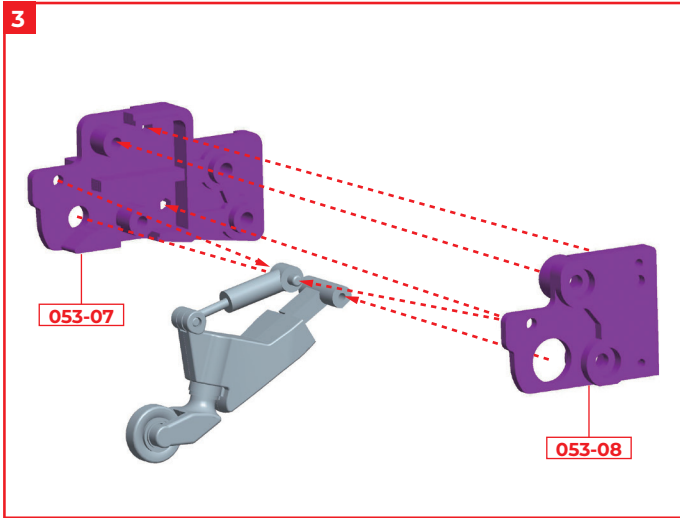

Fit the tail gear frame (L) 053-07 and the tail gear frame (R) 053-08 with the left and right tail gear columns 053-06, 053-09 and the cylinder tube 053-10 in between.

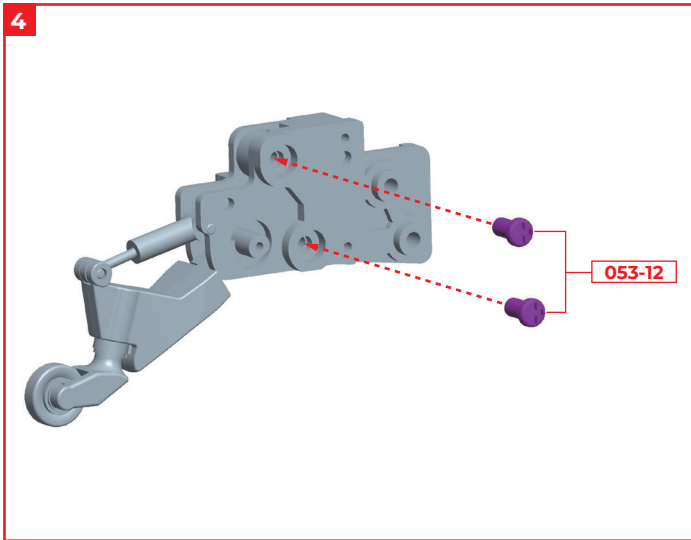

Fix in place with 2 x screws 053-12.

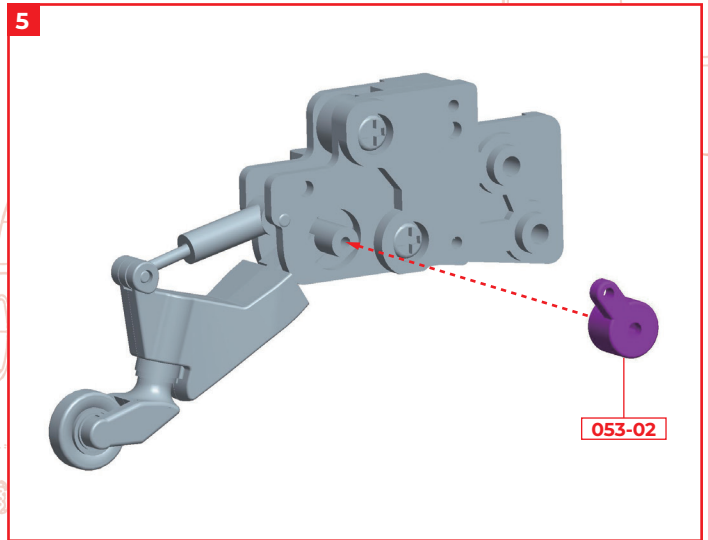

Fit the shaft of the tail gear support (R) 053-06, which is visible through the hole of the tail gear frame (R) 053-08, with the arm 053-02.

NOTE

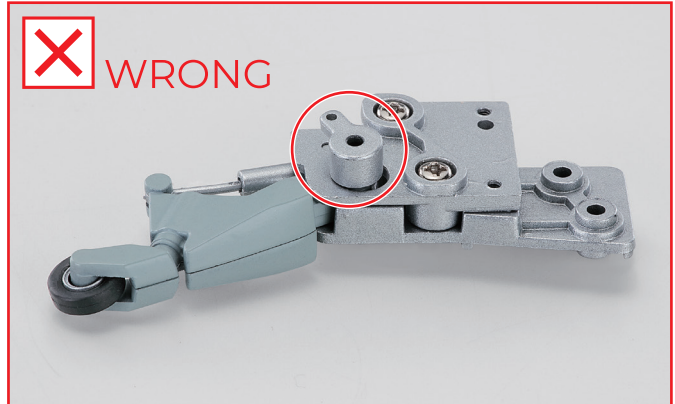
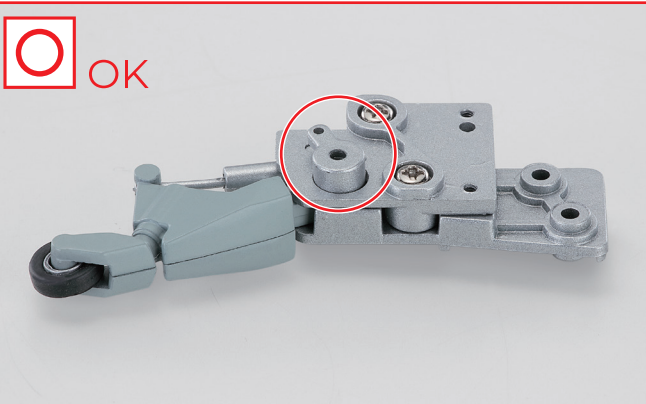

Make sure the arm 053-02 is properly pushed all the way down into the groove.

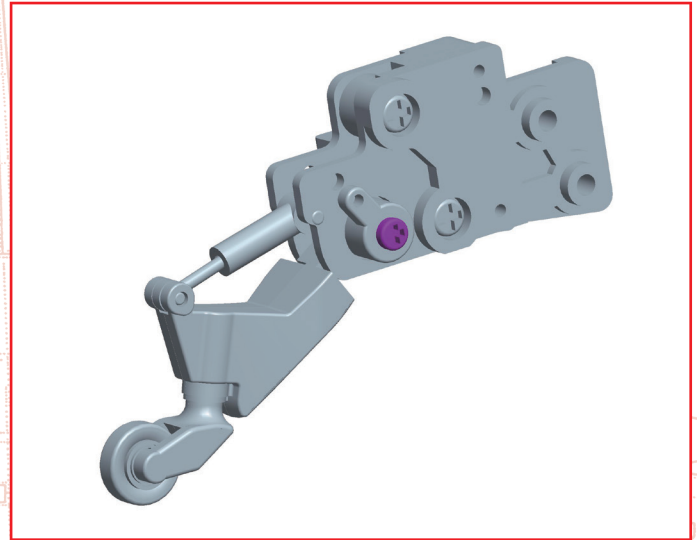
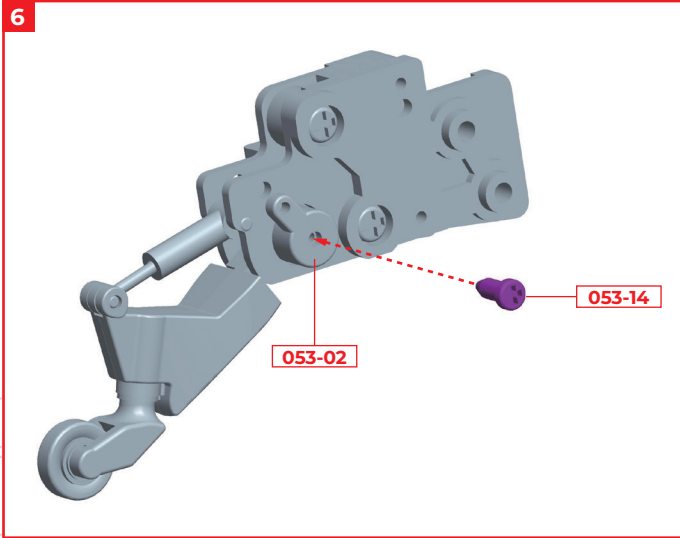

Secure the arm 053-02 with 1 x screw 053-14.

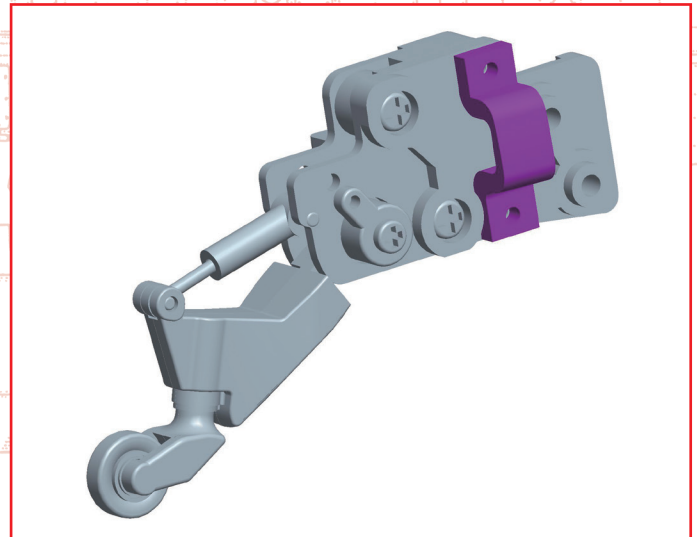
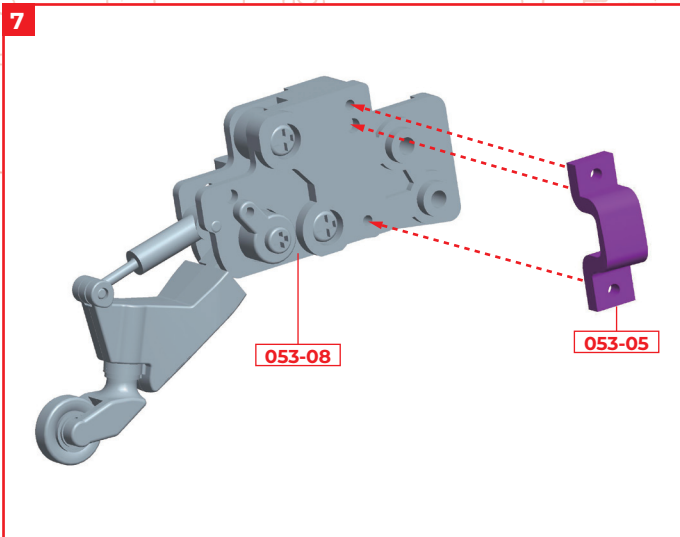

Align the pin of 053-05 and the two screw holes on the tail gear frame (R) 053-08 and fit it.

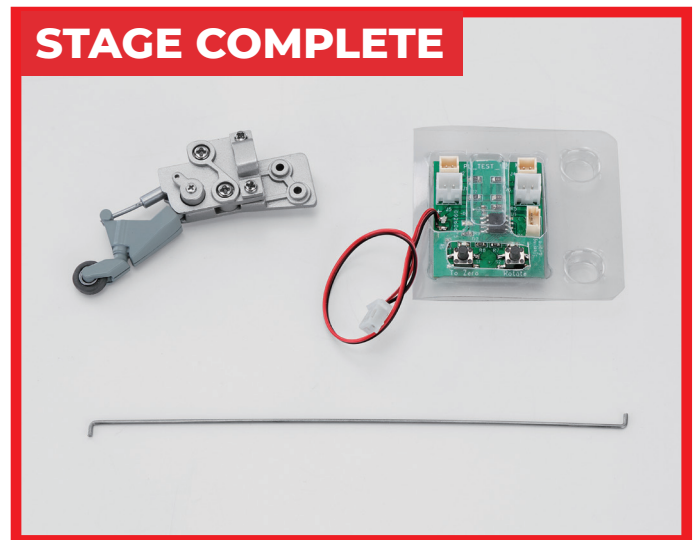
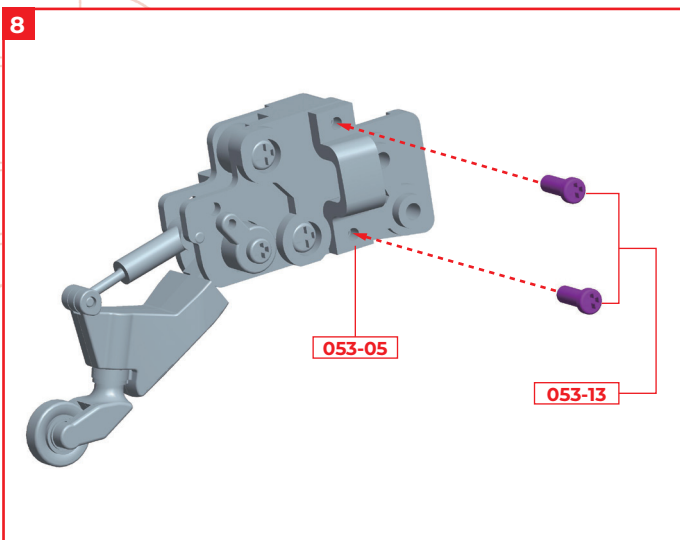

Fix 053-05 with 2 x screws 053-13.