

LONDON TRANSPORT ROUTEMASTER BUS

RM 857



Pack 08

BUILD INSTRUCTIONS

STAGE 71: ELECTRICAL CONNECTIONS

STAGE 72: UPPER DECK LIGHTING
AND OTHER ELECTRICS

STAGE 73: SECOND SECTION OF THE
CEILING FRAMEWORK

STAGE 74: UPPER DECKHANDRAILS

STAGE 75: FRONT DESTINATION BLIND

STAGE 76: DRIVER'S CAB DETAILS

STAGE 77: ELECTRICS AND ROOF PANEL

STAGE 78: INTERIOR UPPER DECK WALLS

STAGE 79: INTERIOR UPPER DECK WALLS

STAGE 80: FRONT WINDOWS AND ELECTRICS

STAGE 71

ELECTRICAL CONNECTIONS

In this stage, we connect the main lighting to the circuit board and test the effect. We also activate the bell pull, engine and horn sounds.

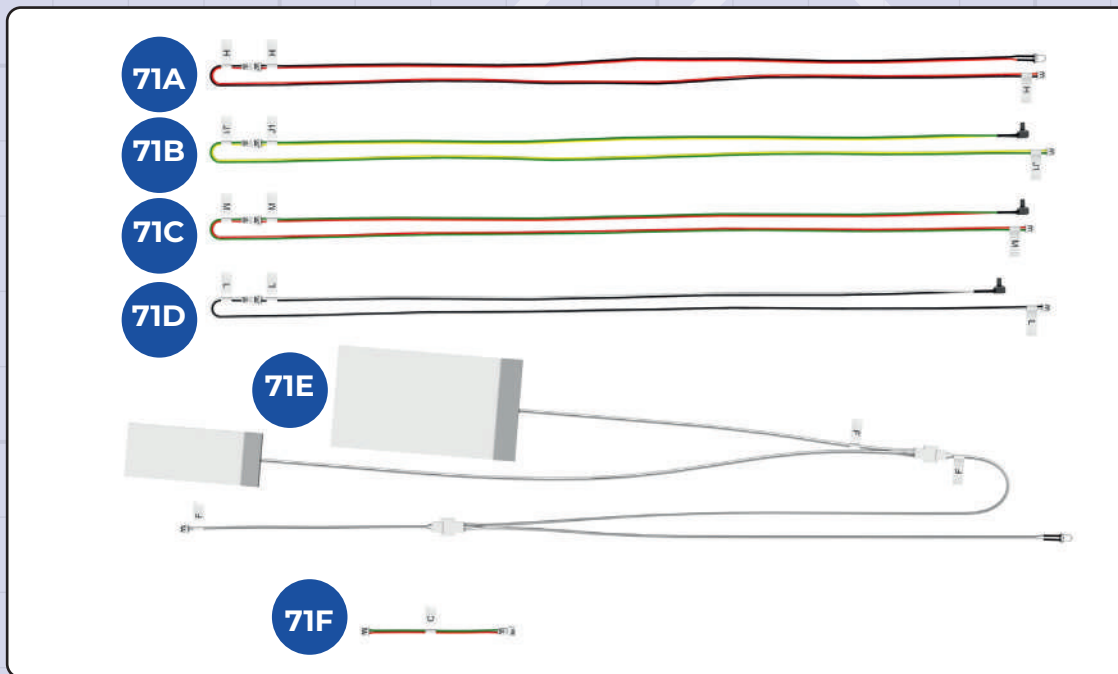

KEY TO PARTS

- 71A** Cable H
- 71B** Cable J1
- 71C** Cable M
- 71D** Cable L
- 71E** Cable F
- 71F** Extender cable C

You will also need three AAA batteries. You may find it helpful to use tweezers to plug in the connections.

1

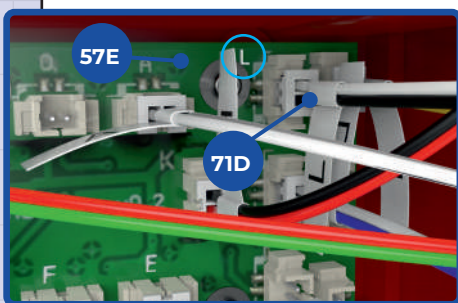

1 Plug cable L **71D** into socket **L** on the circuit board **57E**. This is in the recess beneath the stairs.
NOTE: Cable C is shown plugged in (left), but you may not have fitted it yet.

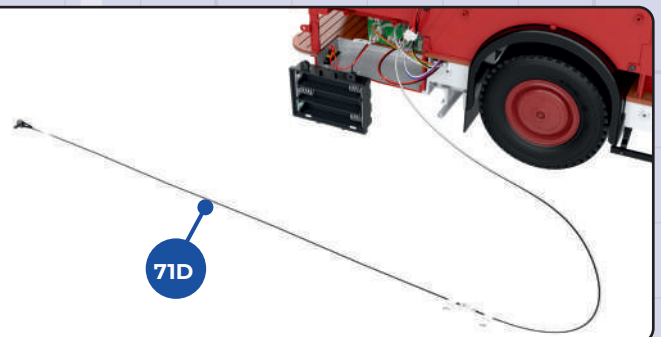

2

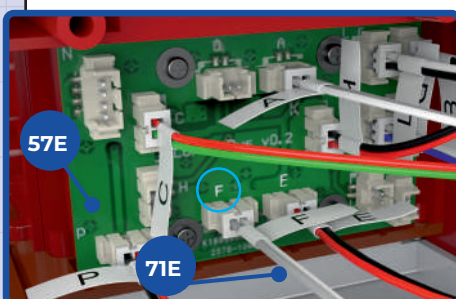

2 Plug cable F **71E** into socket **F** on the circuit board **57E**. Again, cable C is shown plugged in (left), but you may not have fitted it yet.

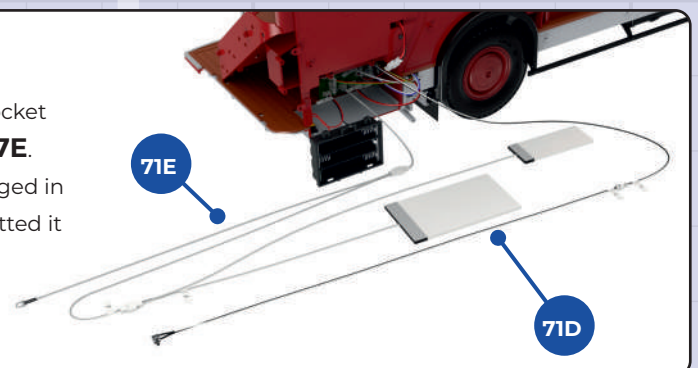

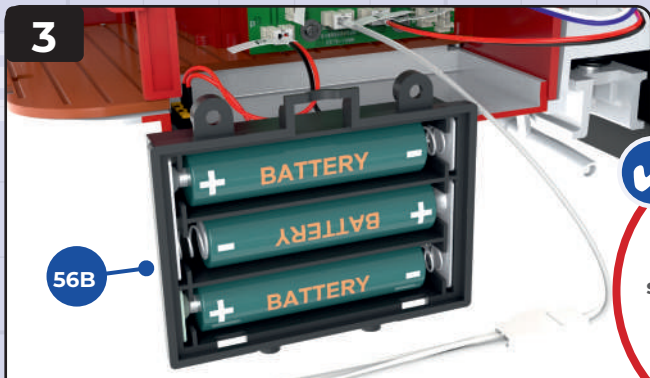

3 Fit three AAA size batteries into the battery box **56B**. Ensure that you position the positive (+) and negative (-) terminals correctly, as shown.

Take care not to move the wires connected to the switch. You may find it helpful to tape the battery box to the side of the bus.

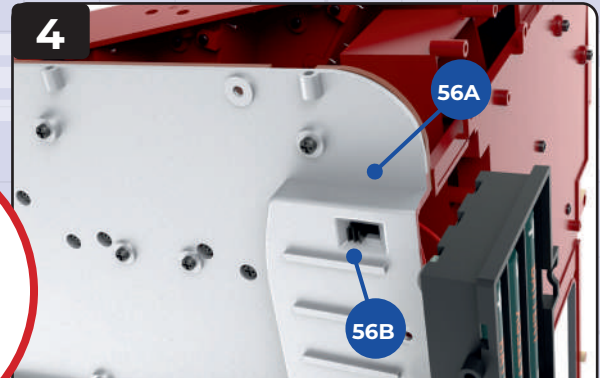

4 Turn on the switch on the battery box **56B**. (This is fitted to the underside of the rear platform **56A**.)

5 Press the button on cable L **71D** to illuminate the two LED panels and the small LED lamp on cable F **71E**. You will see the glow of the lamps better if you turn down the lighting in the area where you are working. Make sure all the connectors are firmly in place as you work.

Always make sure the circuit board is turned off before connecting cables.

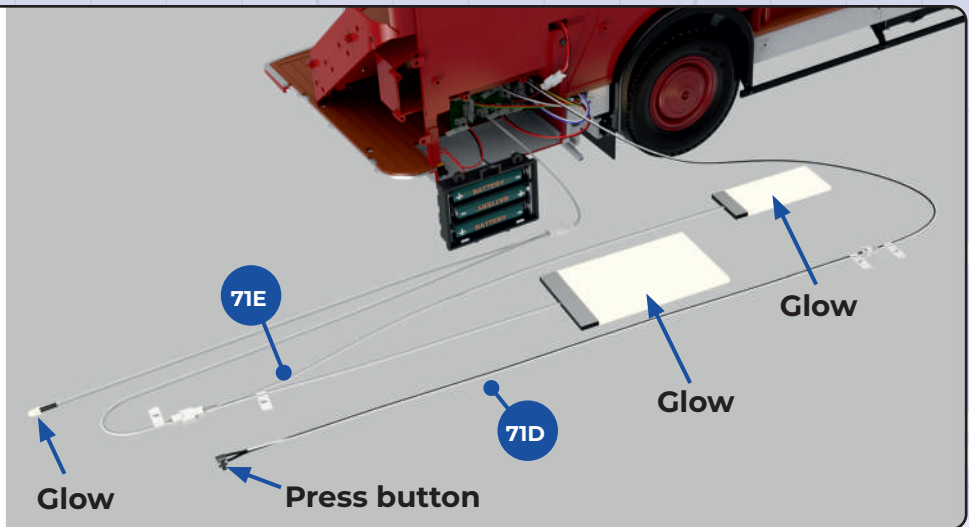

6 Place the lower deck roof assembly next to the lower deck assembly as shown. Identify the end of cable J-J1 **55H**, marked J, which is attached to the roof assembly. Plug it into socket **J** on the circuit board **57E**. Pull the cord **55G** to check the sound of the bell.

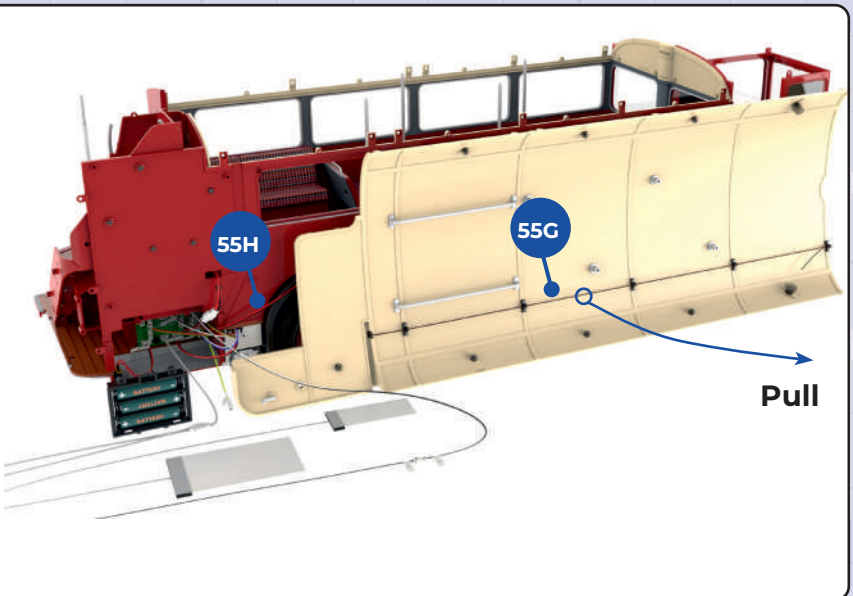
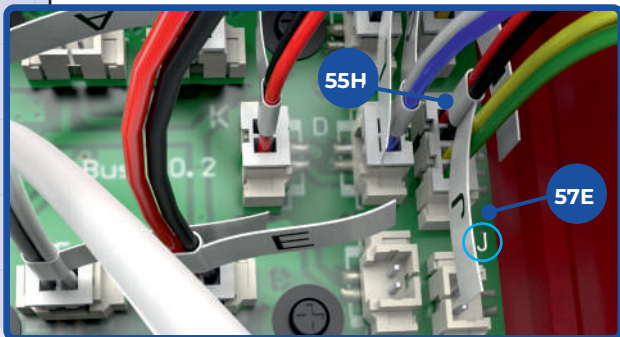

ROUTEMASTER BUS RM 857

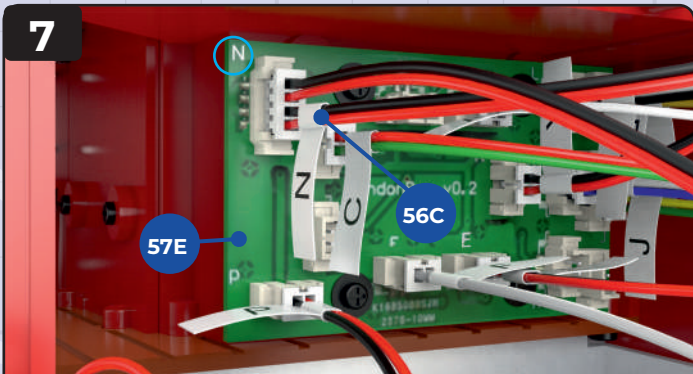

7 Plug the wide end of cable N **56C**, coming from the roof assembly, into socket **N** on circuit board **57E**. Again, cable C is shown plugged in, but is not fitted yet.

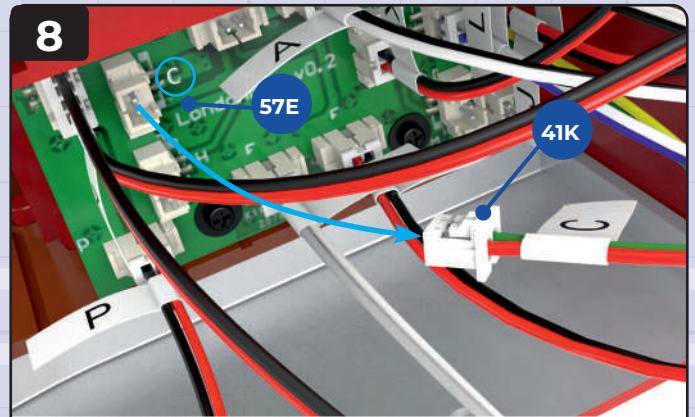

8 If you have fitted cable C **41K**, unplug it from socket **C** on the circuit board **57E**.

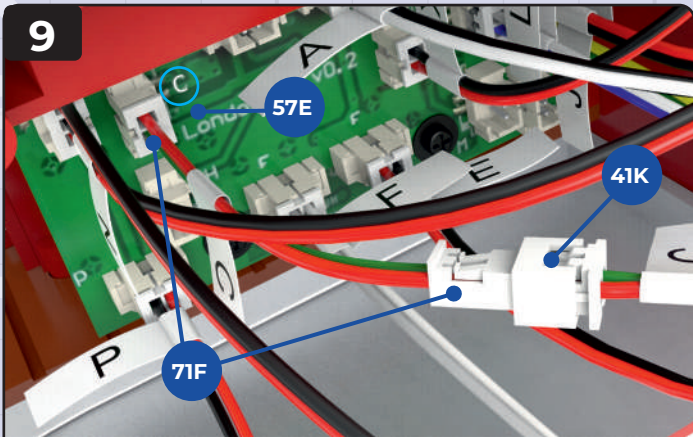

9 Plug one end of the extender cable C **71F** to the end of cable C **41K** and plug the other end into socket C on the circuit board **57E**.



10 Press the switch **38N** in the driver's cab to check the horn sound. Press the switch **38M** to check the LED lamps on the lower deck ceiling and the headlights and sidelights on the front of the bus, as shown in the insets below.

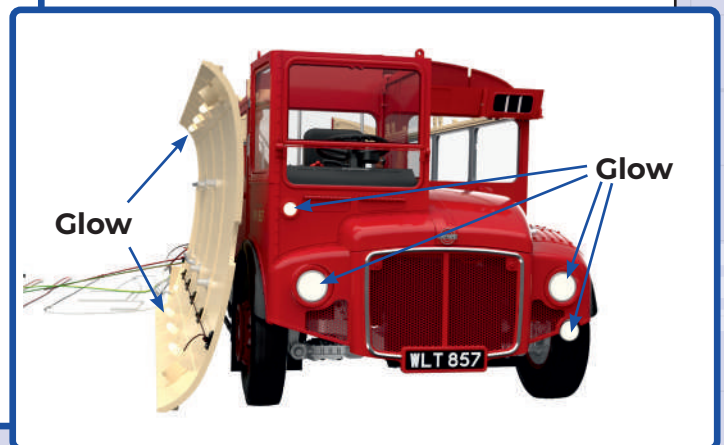
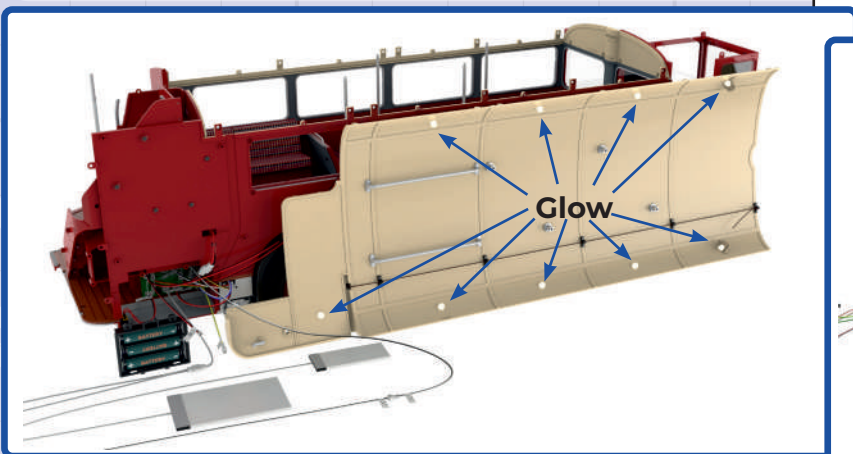

11

11 Plug cable H **71A** into socket **H** on the circuit board **57E**.

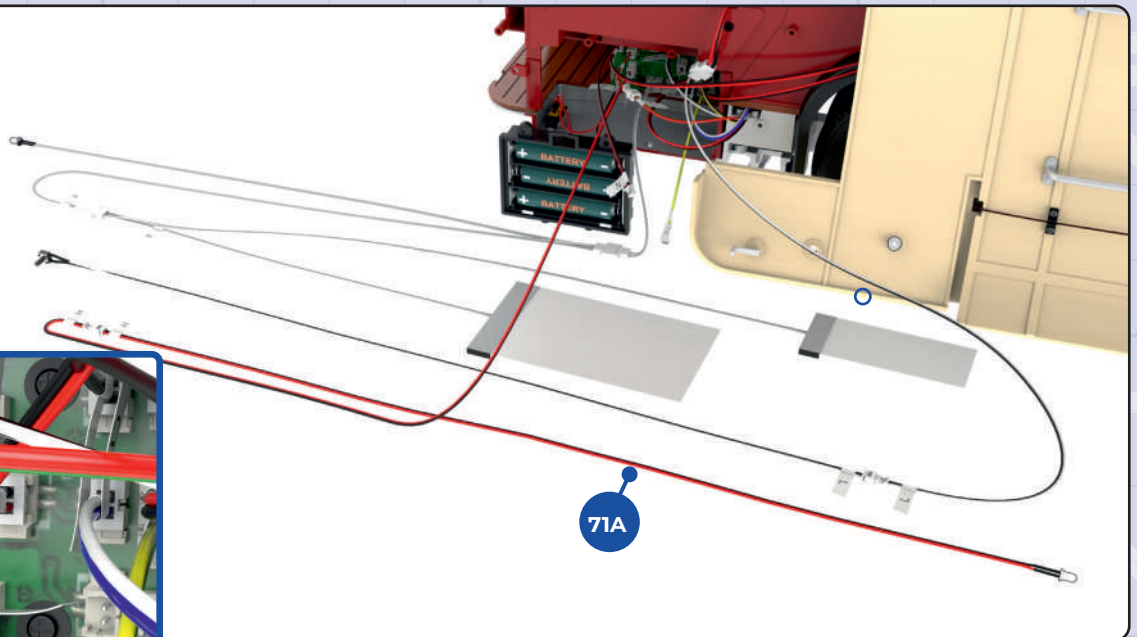
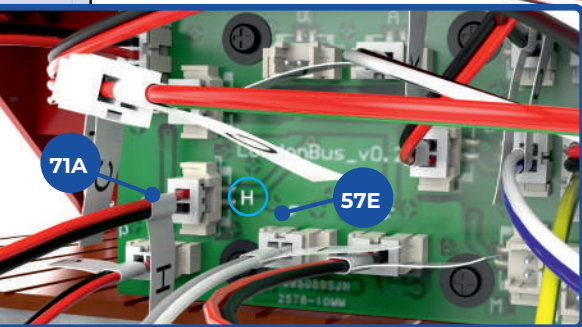

12

12 Plug cable M **71C** into socket **M** on the circuit board **57E**.

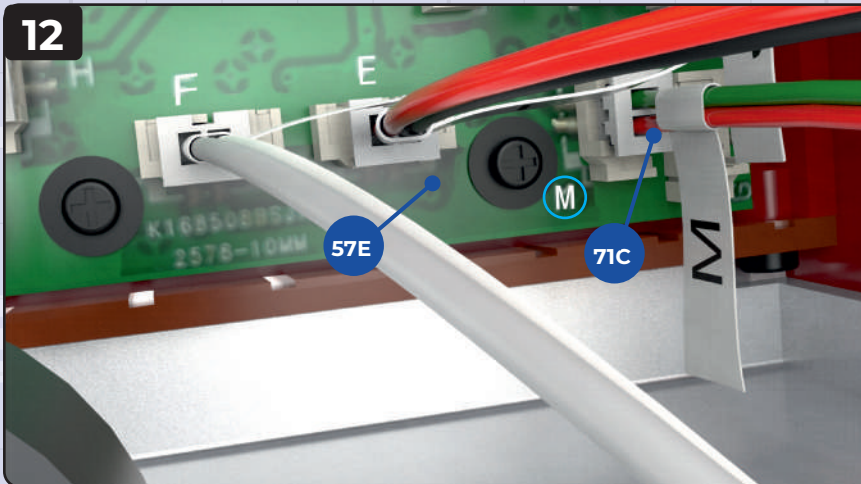

13

13 Press the button on the end of cable M **71C** to check that the LED on the end of cable H **71A** lights up. You will see the glow effect better if you darken the area where you are working.

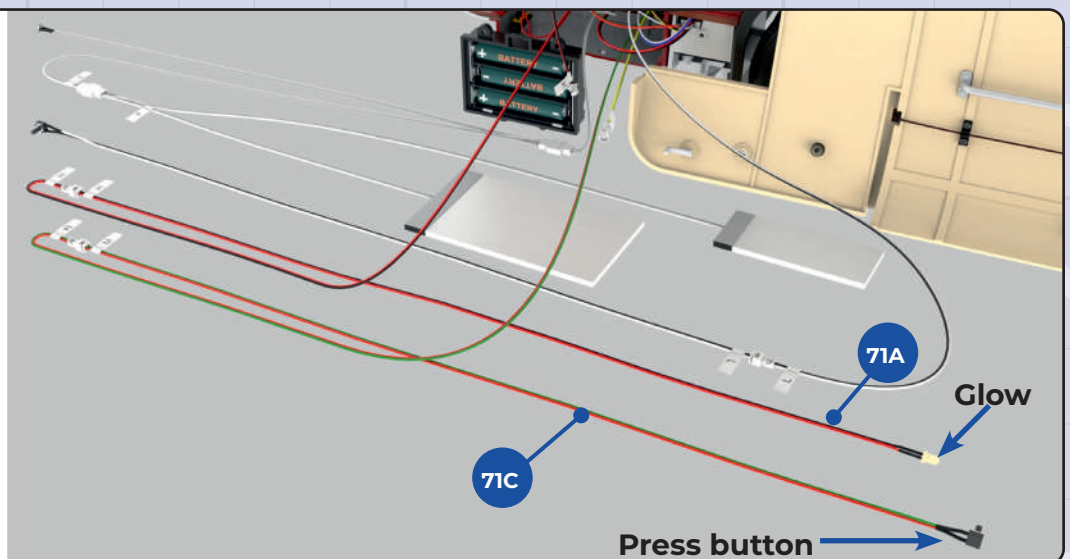

14

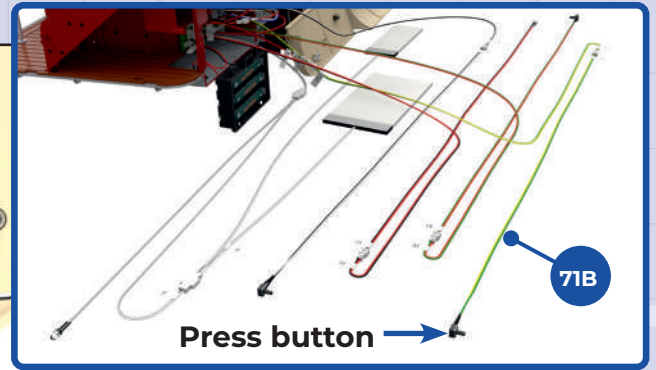
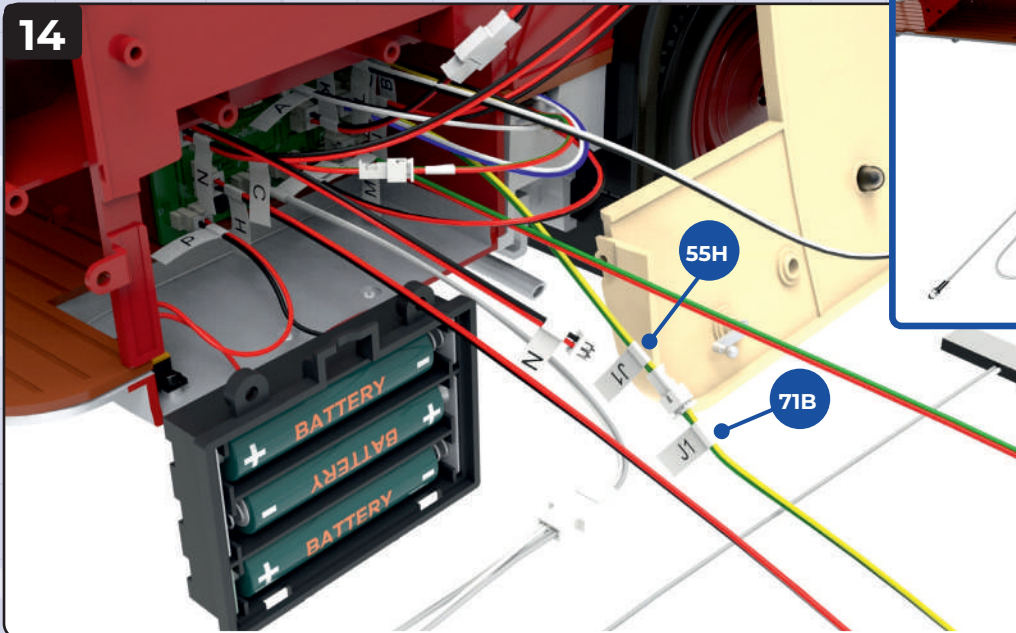

14 Connect cable J1 **71B** to cable J-J1 **55H**. Press the button on the end of cable J1 **71B** to check the engine sound.

Finished views

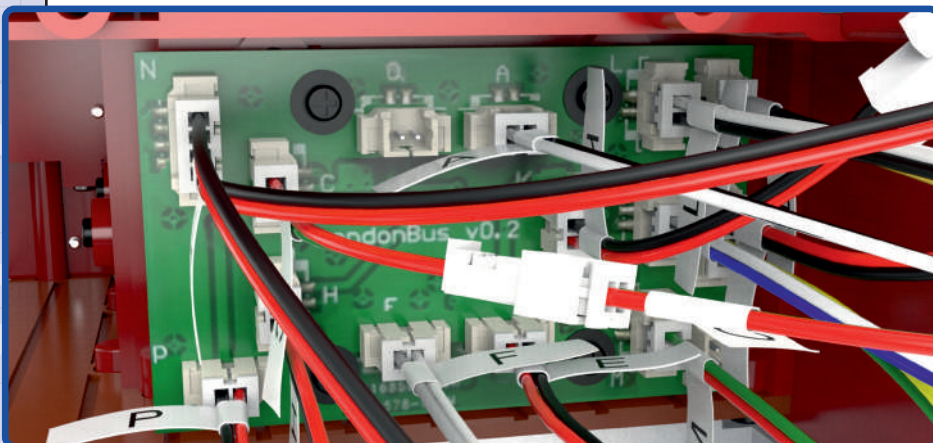
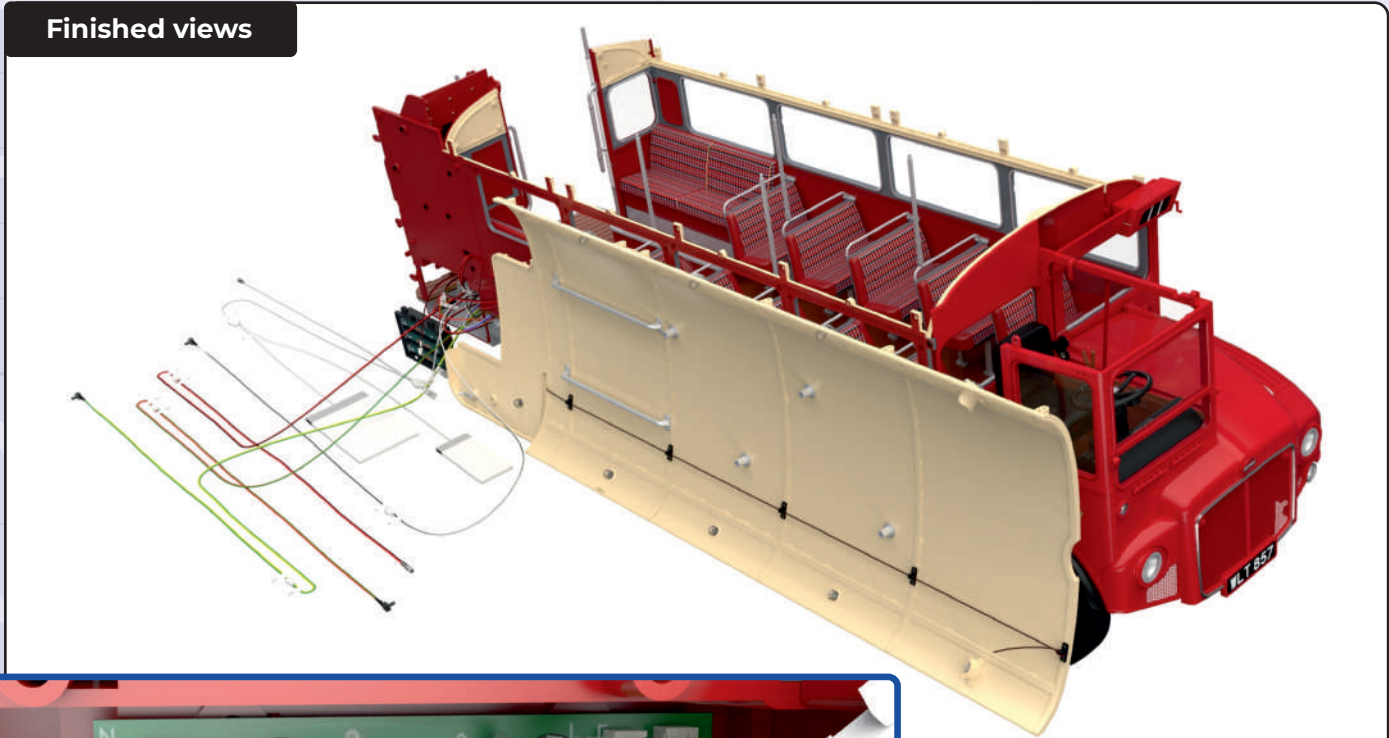

STAGE 72

UPPER DECK LIGHTING AND OTHER ELECTRICS

In this stage, we continue to fit the electrical connections, including the lighting for the upper deck and the rear lights.



KEY TO PARTS SUPPLIED

- 72A** Cable N
- 72B** Cable O
- 72C** Cable G

✓
 When working on the electrics, always make sure that the power is turned off before you plug in any cables.

1

1 Connect cable N **72A** to the free socket on the end of cable N **56C** (already attached to the circuit board). The LEDs on cable N **72A** are the lights for the ceiling of the upper deck.

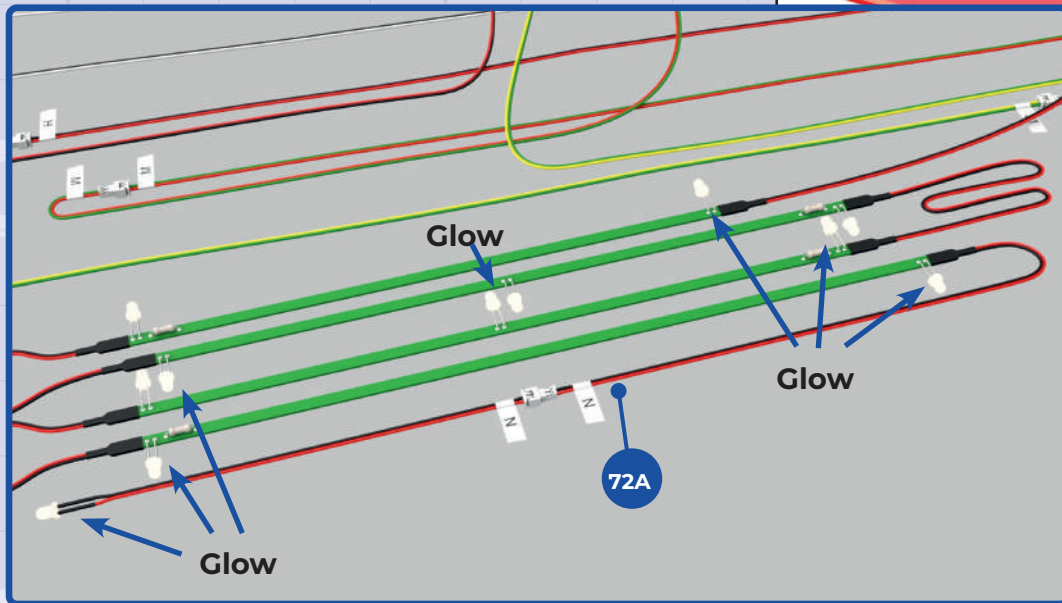
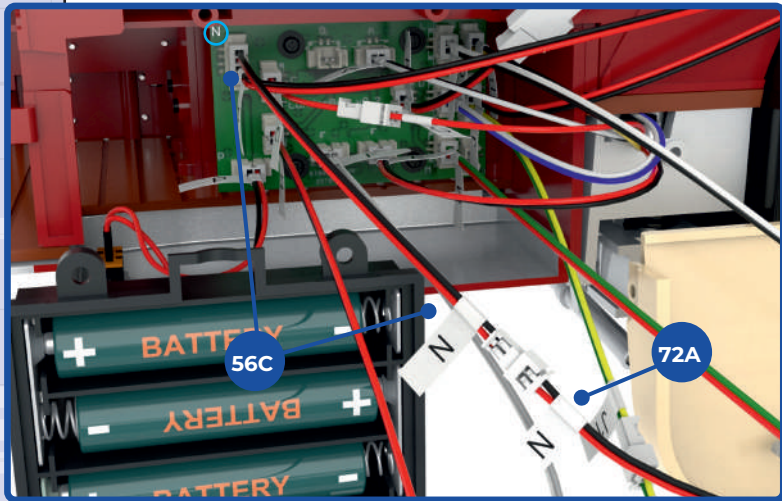
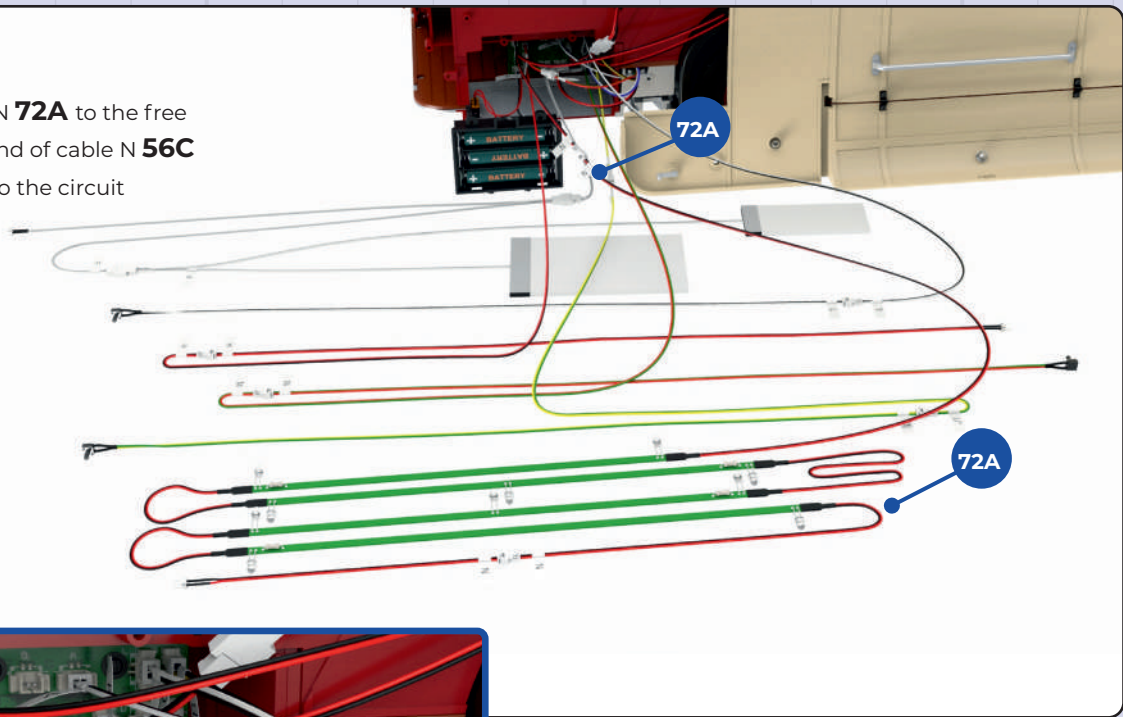

2 After checking all of the connectors are fitted securely, press switch **38M** to check that the LEDs illuminate on cable N **72A**. To see the glow effect better, darken the area where you are working.

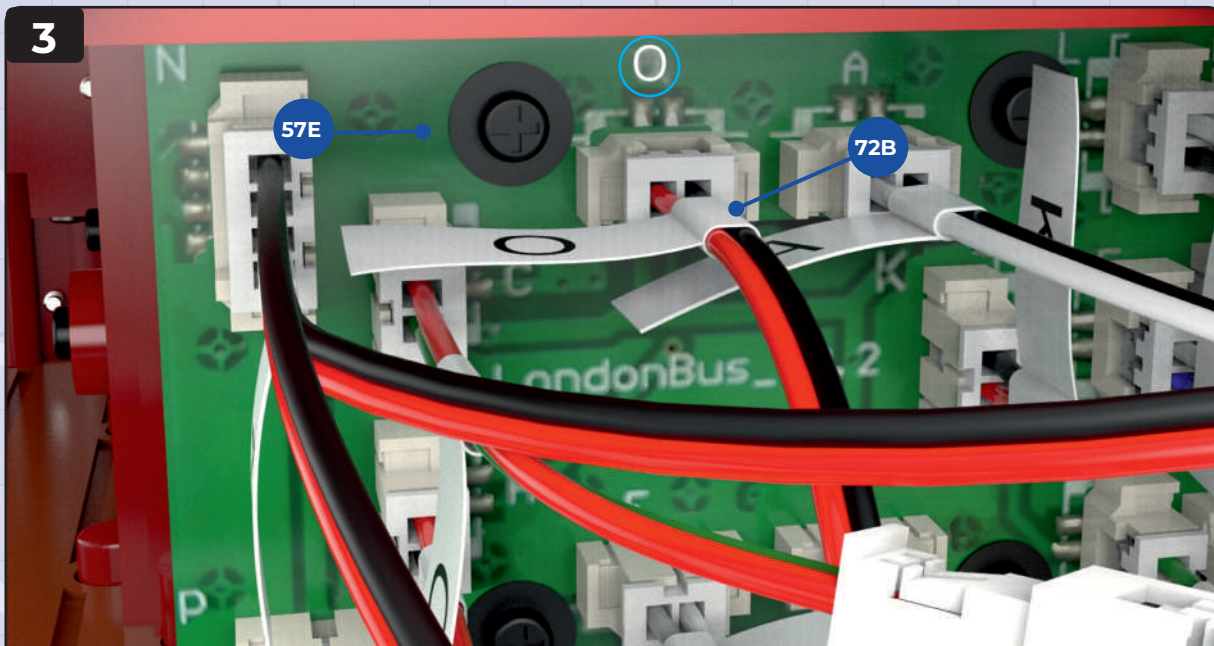

3 Plug cable **O 72B** into socket **O** on the circuit board **57E**.



4 Press switch **38M** in the driver's cab to illuminate the red LEDs on cable **O**. Press the brake pedal **37A** to see that the LEDs become brighter. These are the rear lights, which also act as brake lights.

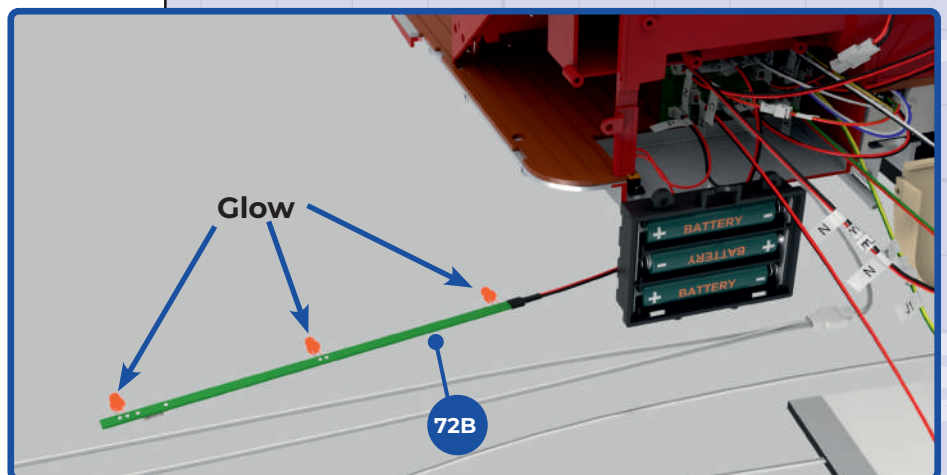

5

5 Plug cable G **72C** into socket **G** on the circuit board **57E**.

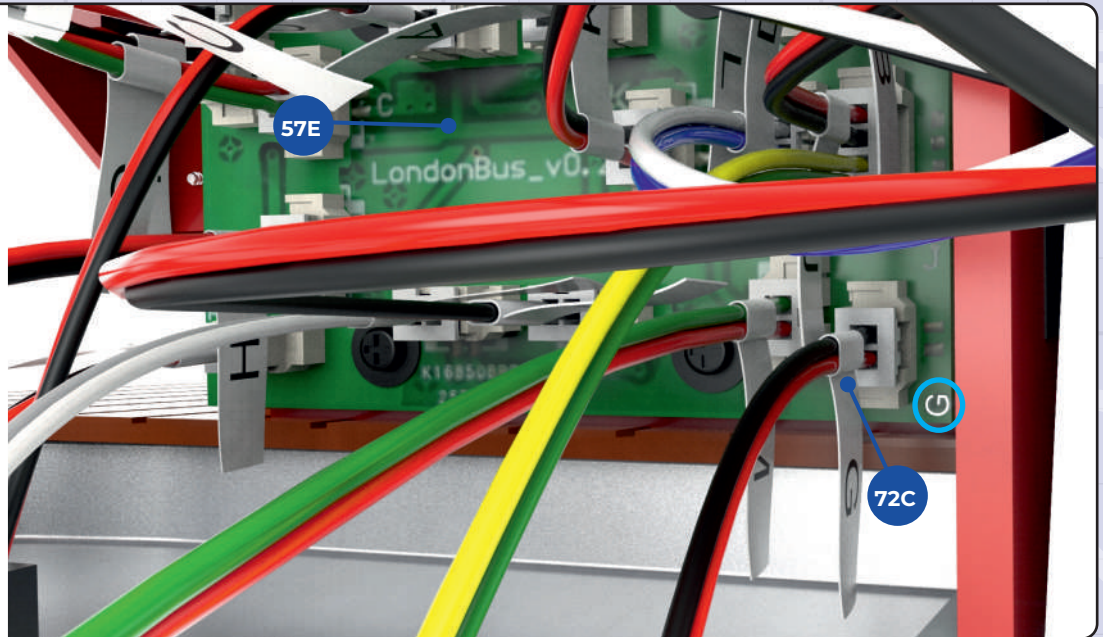

6

6 Press switch **38M** so that you can see two flashing LEDs on cable G **72C**. These are indicators.

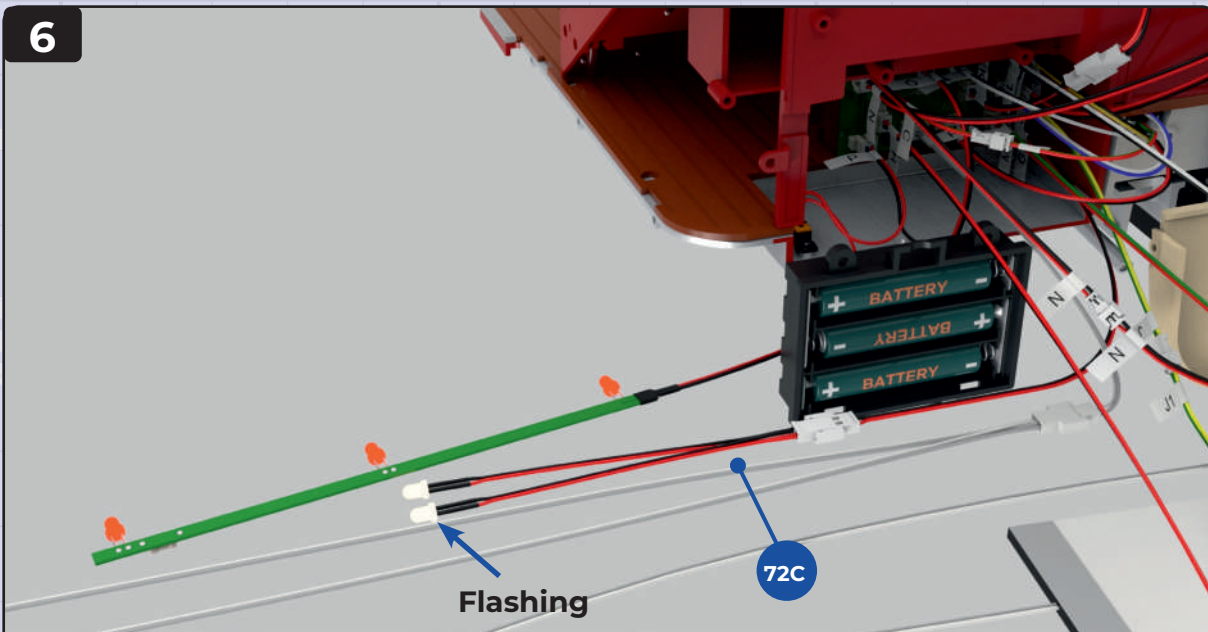

ROUTEMASTER BUS RM 857

Finished views

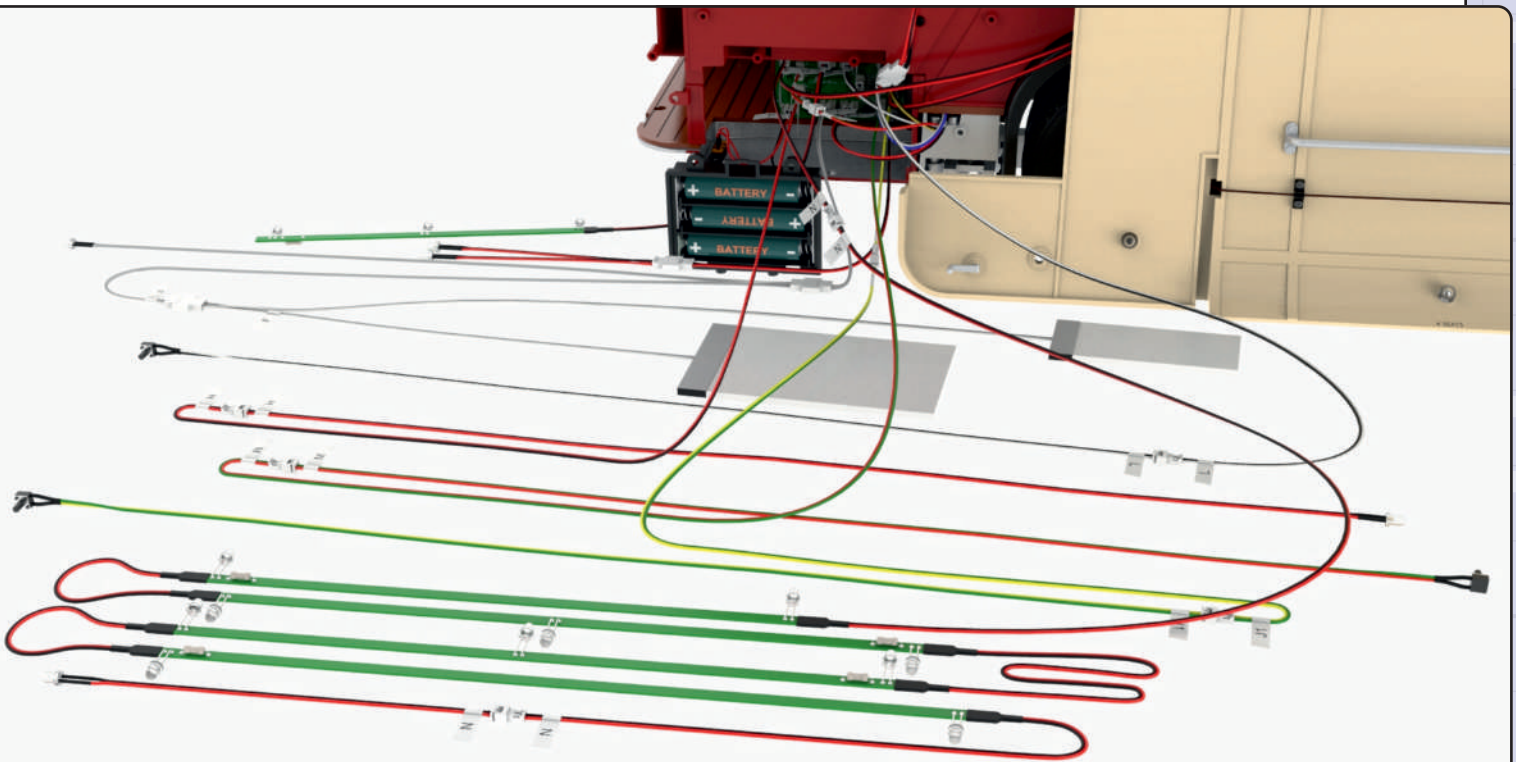
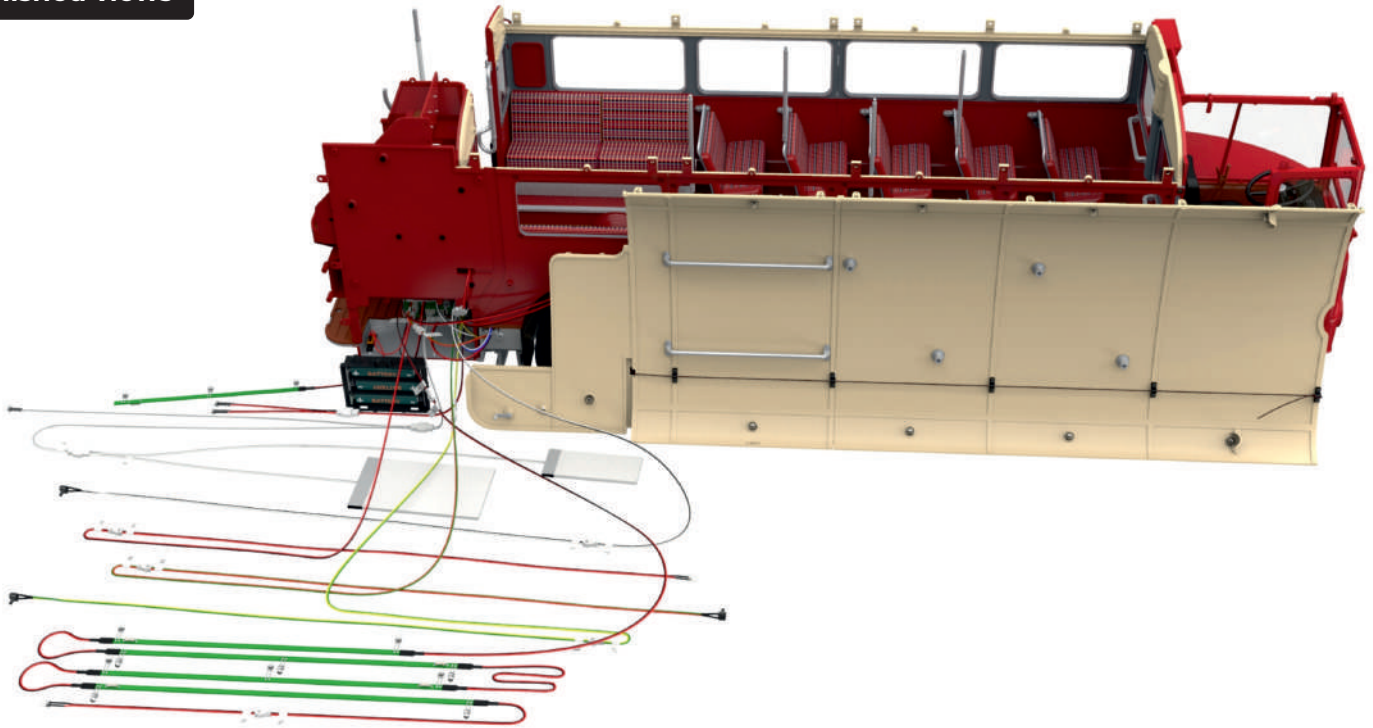

You may find it helpful to tidy the cables and hold them in separate bundles with small cable ties or short lengths of wire.

STAGE 73

SECOND SECTION OF THE CEILING FRAMEWORK

In this stage, fit a second section of framework to the underside of the floor of the upper deck. The ceiling of the lower deck will be fitted to this framework later.

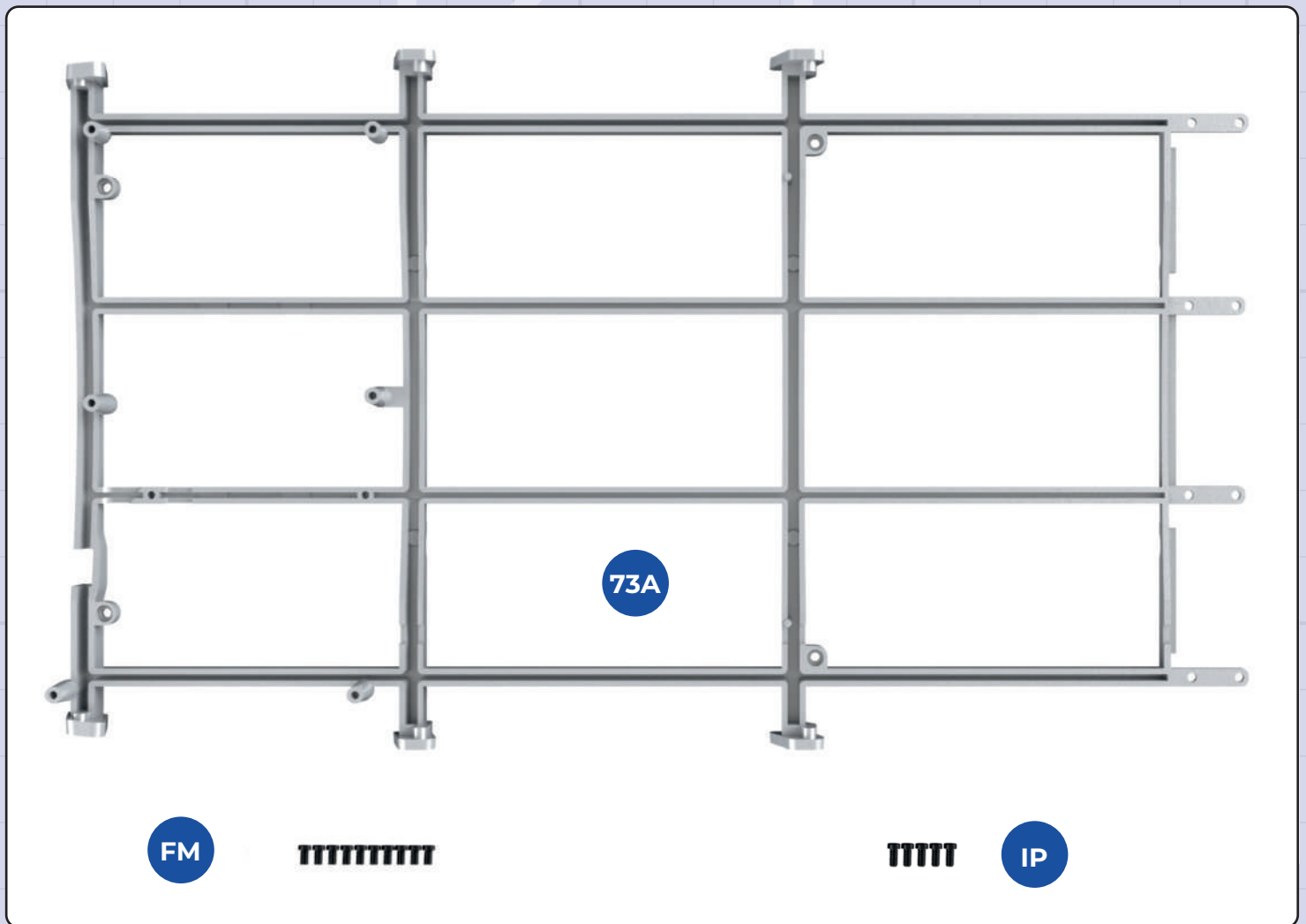

KEY TO PARTS SUPPLIED

73A Second section of the ceiling framework

FM 2.3 x 4mm (x10)

IP 2.3 x 5mm (x5)



1

1 Position the second section of the lower deck ceiling framework **73A** on the underside of the floor of the upper deck. Note that there are four tabs on the end of part **73A**, each with two screw holes. These should be aligned with sockets on the previous section of framework **70A**. After making sure that the tabs are fully inserted, fix in place with eight **FM** screws.

✓ While you are fixing the ceiling framework, make sure that you do not damage the seats that are already fitted to the upper deck.

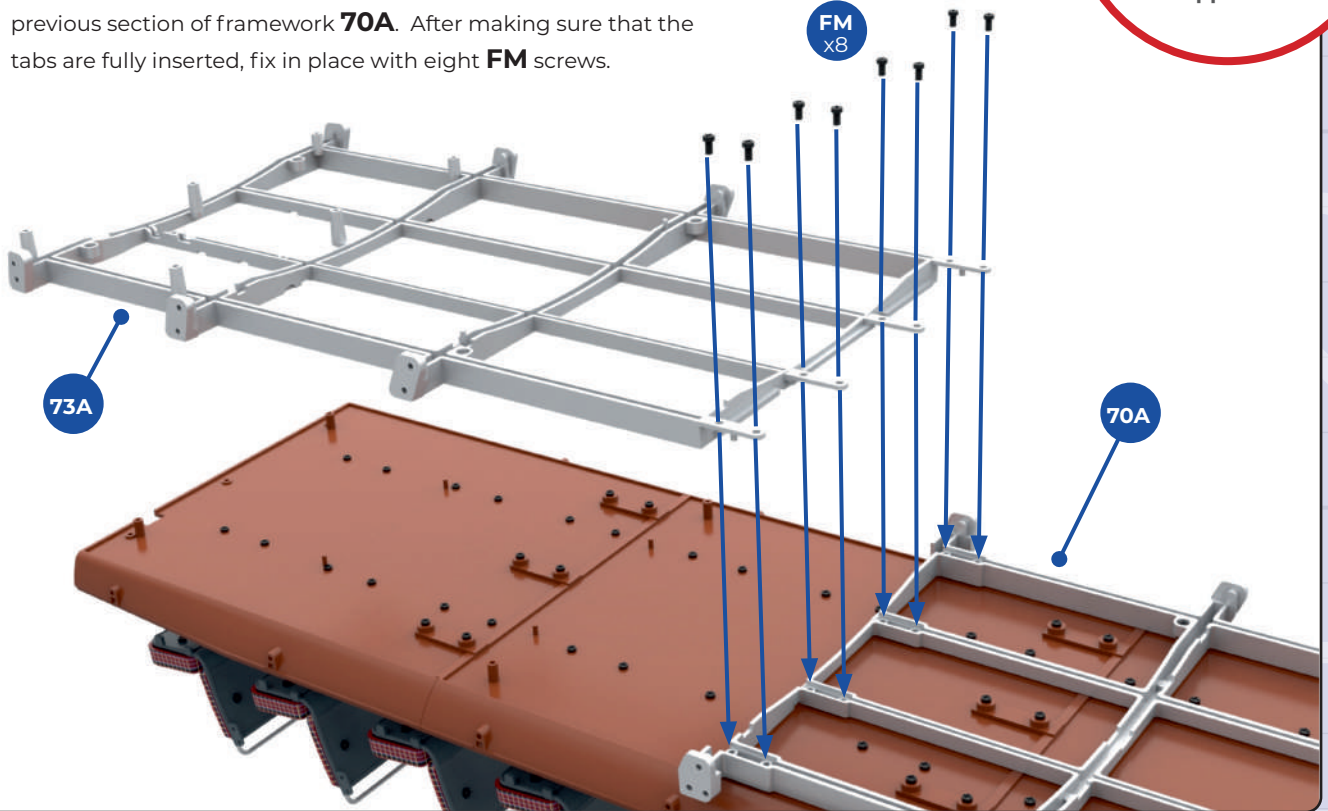

A Routemaster construction diagram, drawn up at the Chiswick Works, shows how the framework supports the floor of the upper deck and provides fixing points for the ceiling of the lower deck.

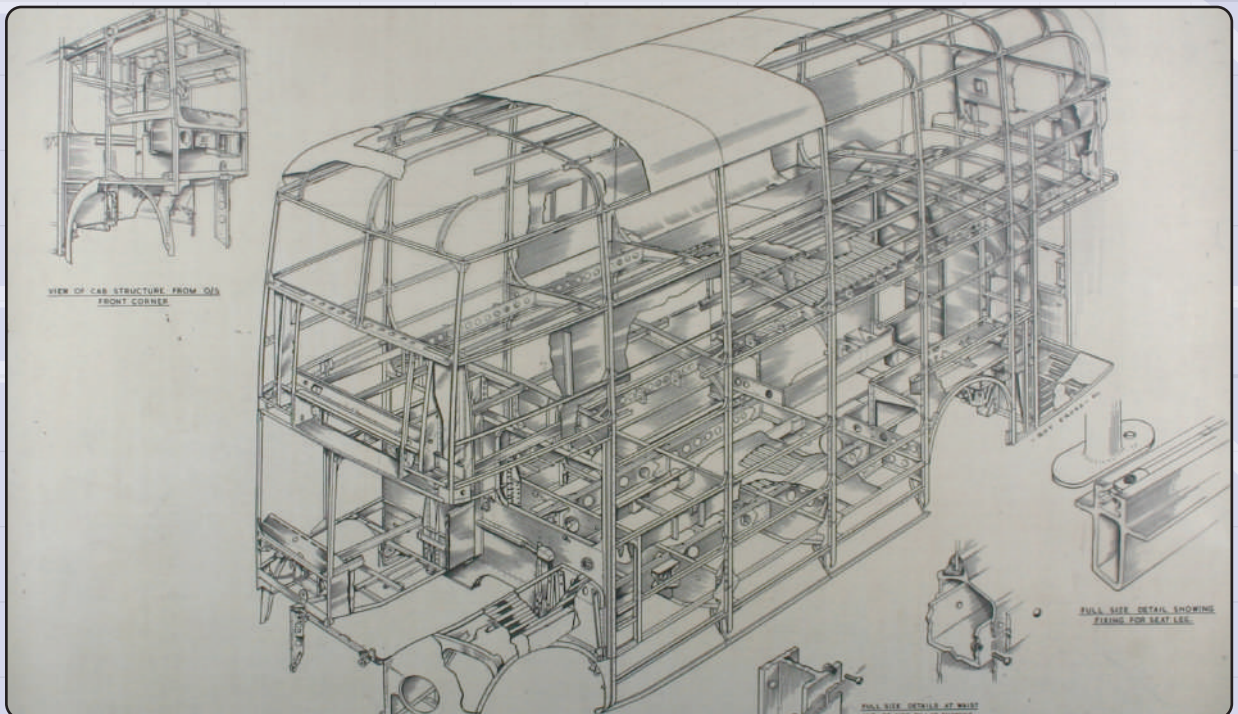

2

2 Check the fixing points for the rest of the framework: note that two of the screws fit into sockets on part **69A** and two fit into sockets on part **68A**. Fix in place with four **IP** screws, again taking care not to damage the previously fitted seats. The inset shows the framework in place.

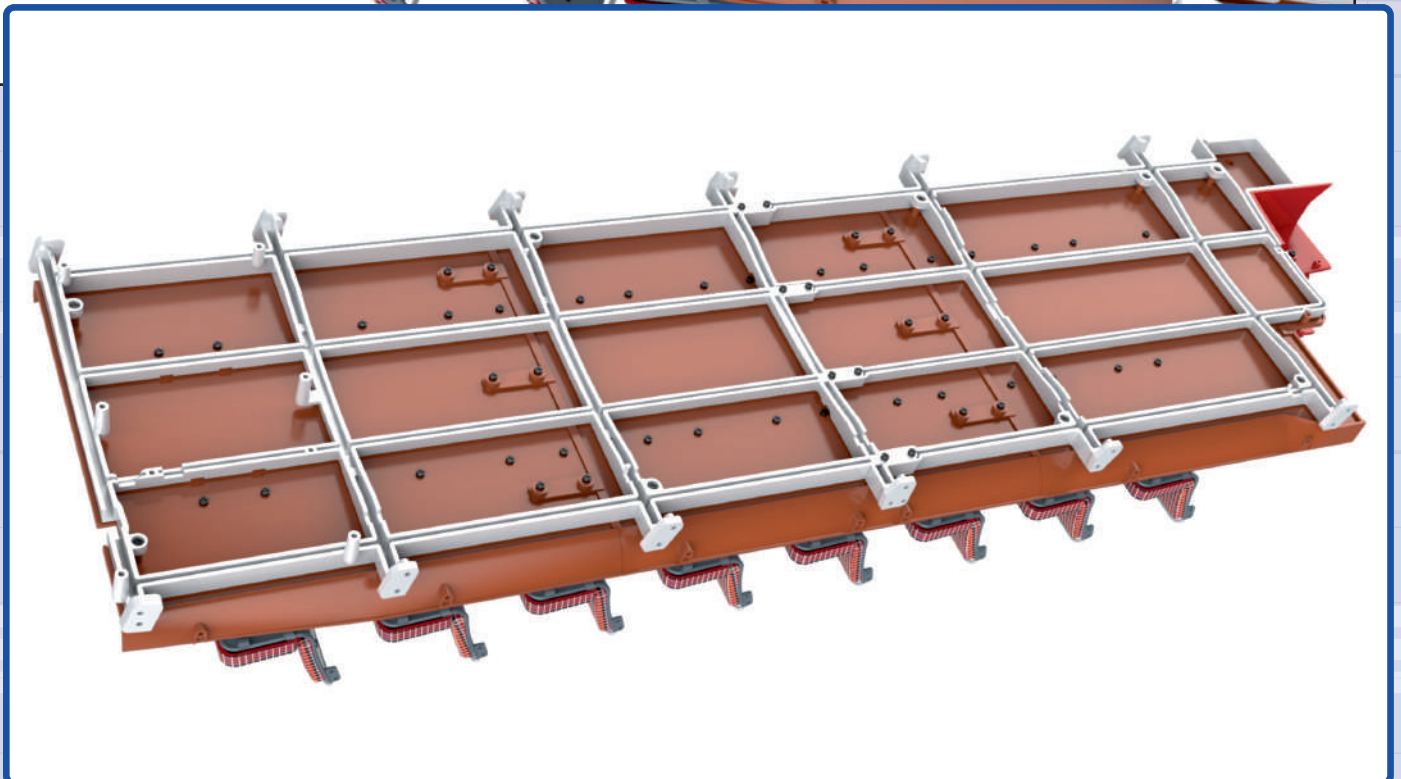
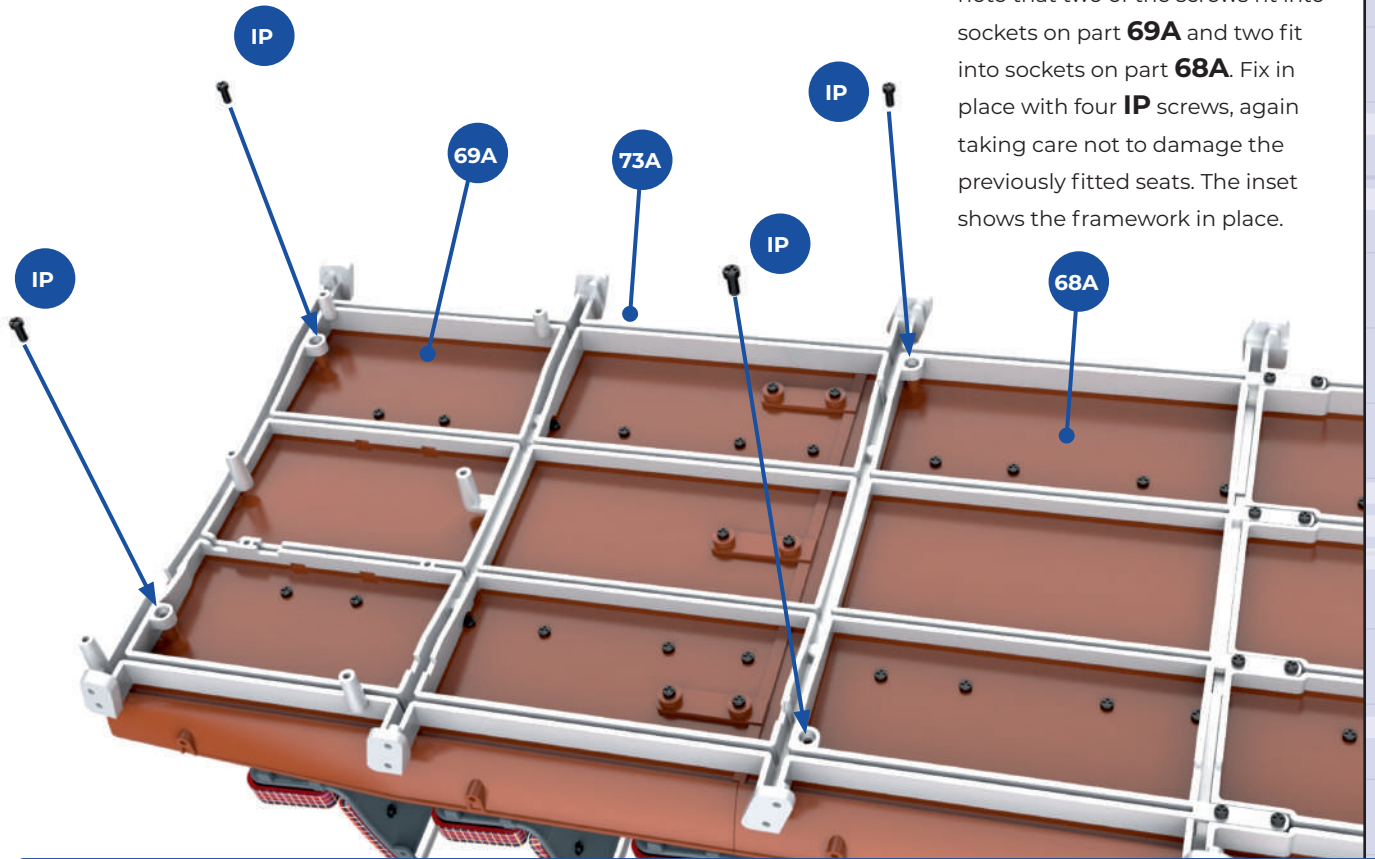

Finished views

The framework that the lower deck ceiling will be fitted to is fixed to the floor of the upper deck.

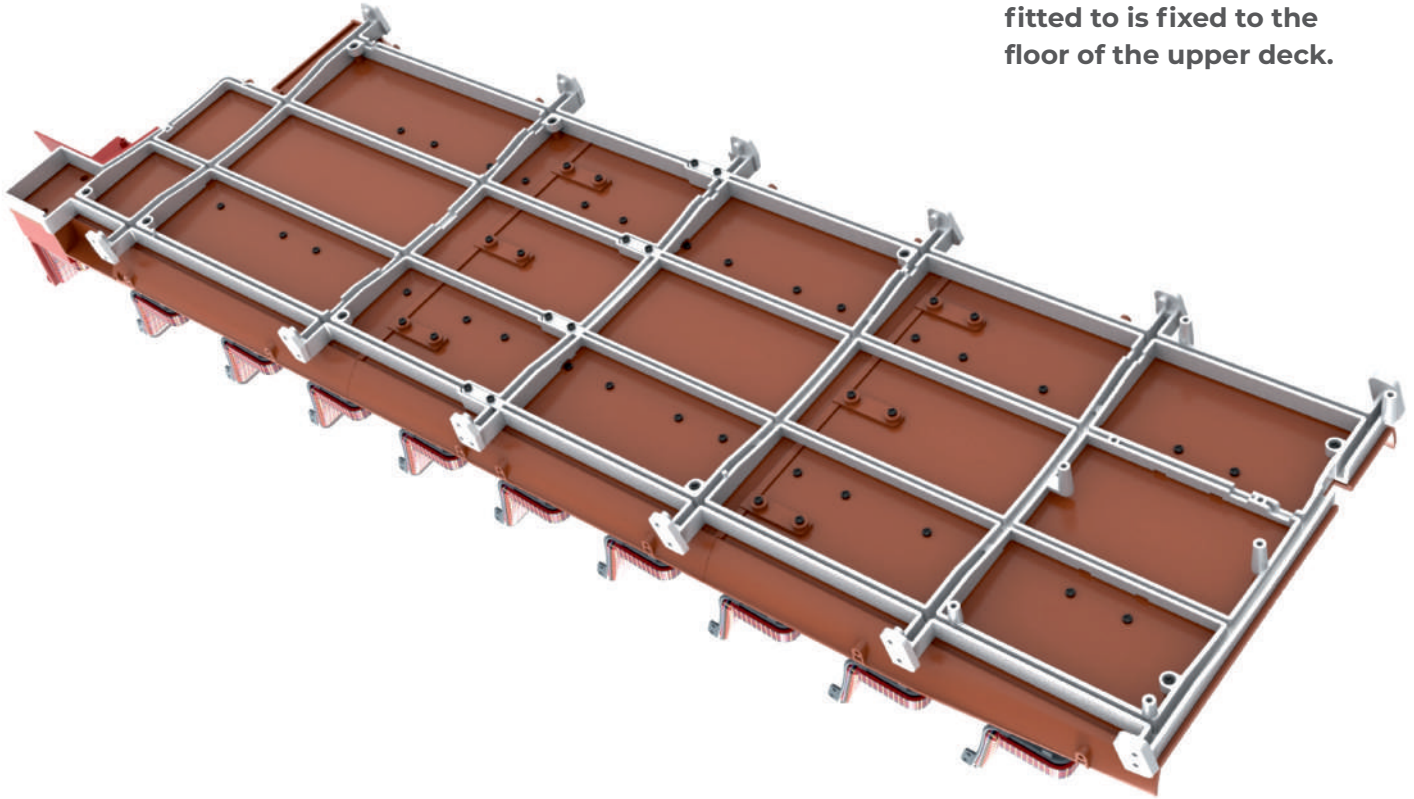

STAGE 74

UPPER DECK HANDRAILS

In this stage we supply part of the front wall of the upper deck and the rear wall, around the top of the stairs.
Handrails are fitted to each of these sections.

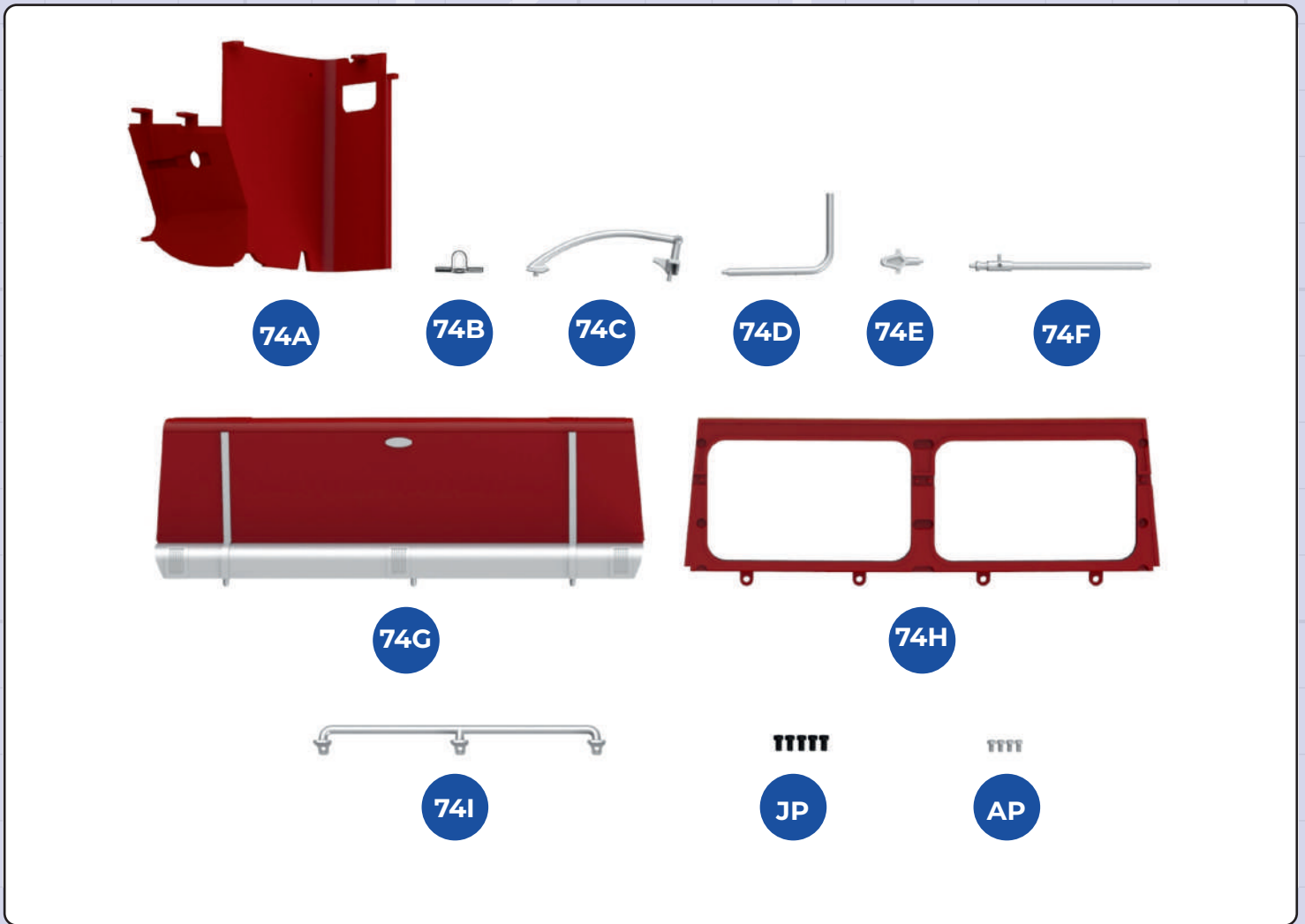

KEY TO PARTS SUPPLIED

- 74A** Rear wall
- 74B** Lamp
- 74C** Handrail
- 74D** Handrail
- 74E** Handrail support

- 74F** Grab pole
- 74G** Front wall
- 74H** Front window frame
- 74I** Handrail

- JP** 2.3 x 4mm (x5)
- AP** 1.7 x 3mm (x4, silver)

1

Take the rear wall **74A**, which will fit around the top of the stairs. Check the orientation of the part and push-fit the curved section of handrail **74C** into the top of the wall. Push-fit the lamp **74B** into the recess in the wall, so that the light bulb goes through the hole.

2

Turn the rear wall **74A** around and push-fit the handrail support **74E** into the notch in the top of the wall. Take the angled section of handrail **74D** and fit one end into the socket in the curved handrail **74C**. At the same time, fit the peg on the top of part **74E** into the socket on the underside of part **74D**.

3

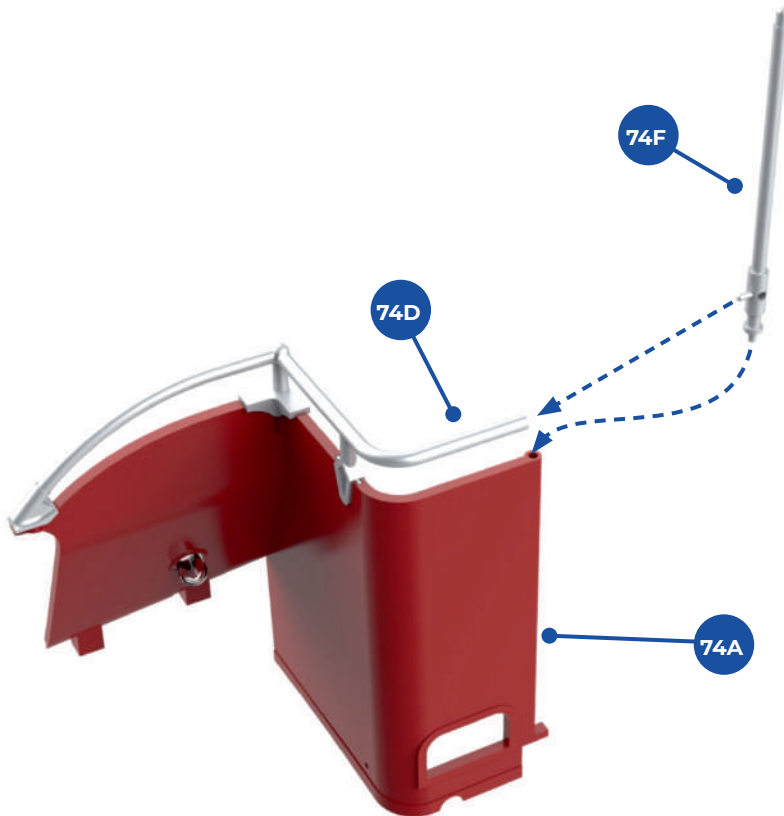

3 Take the grab pole **74F** and fit the peg on the lower end of the pole into the socket on the top corner of the rear wall **74A**. At the same time, fit the peg on the side of the pole **74F** into the socket at the end of part **74D**.

4

4 Take the front wall **74G** and check which side faces the inside of the upper deck. Take the handrail **74I** and position it along the top edge of the front wall so that the screw holes in the rail are aligned with the sockets on the top edge of the front wall. Fix in place with three **AP** screws.

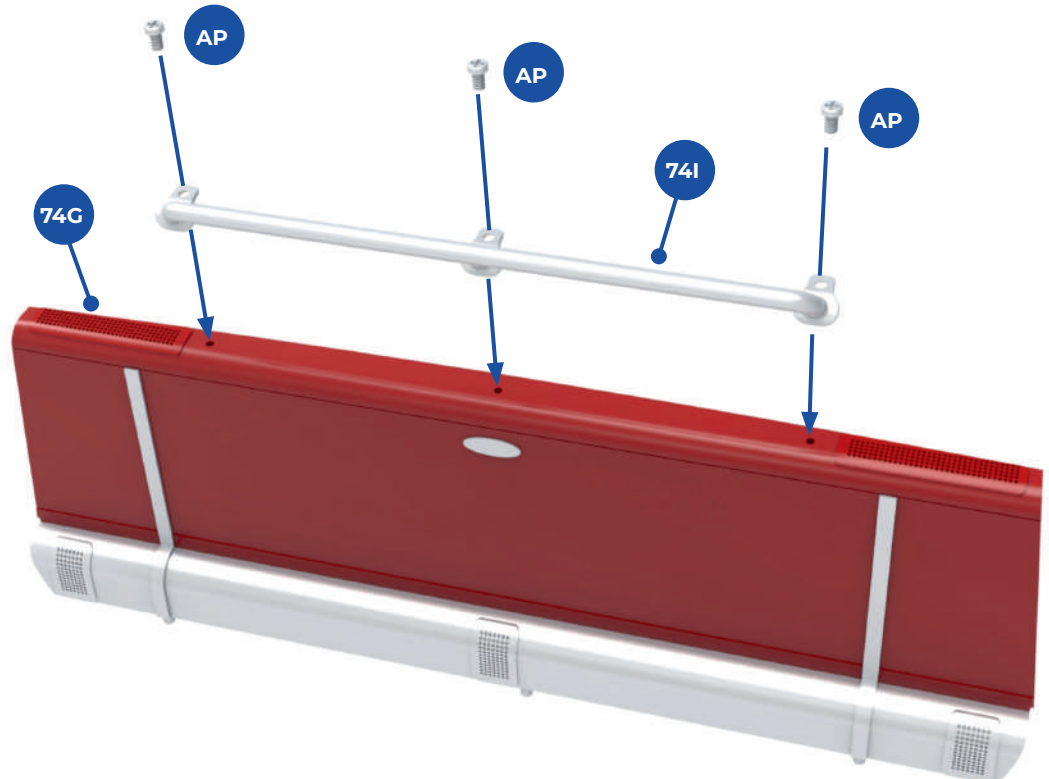

5

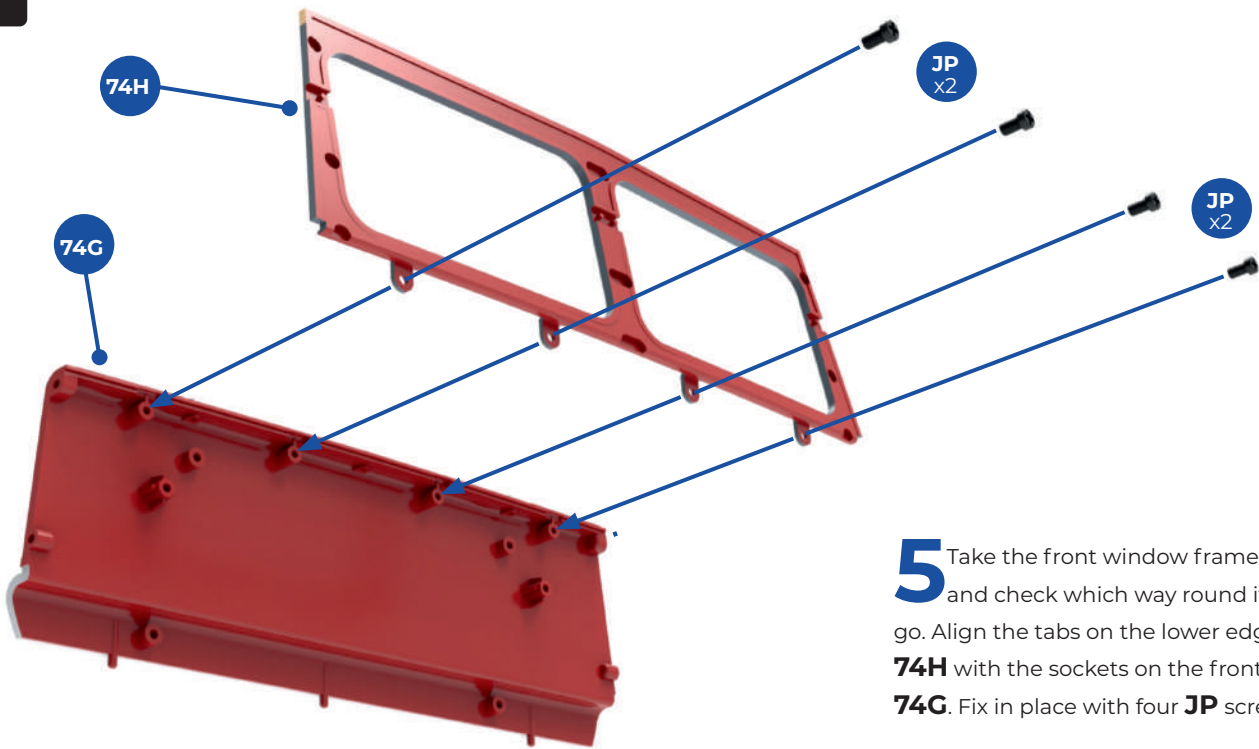

5 Take the front window frame **74H** and check which way round it should go. Align the tabs on the lower edge of part **74H** with the sockets on the front wall **74G**. Fix in place with four **JP** screws.

6

6 The front wall can now be fitted to the front of the upper deck, by inserting the three pegs on the lower edge of part **74G** into the corresponding holes in the floor of the upper deck **69A**. This fixing is not secure at this stage, so you may prefer to wait until you have the corner sections of the front wall before fitting part **74G** in place.

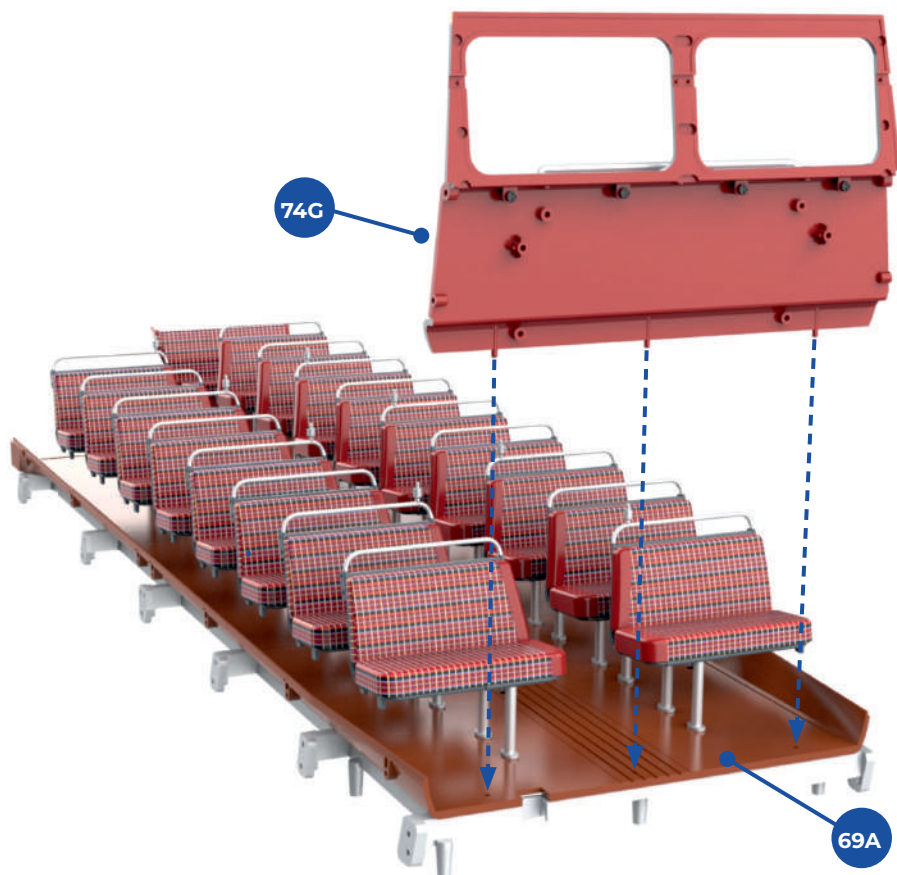

Finished Views

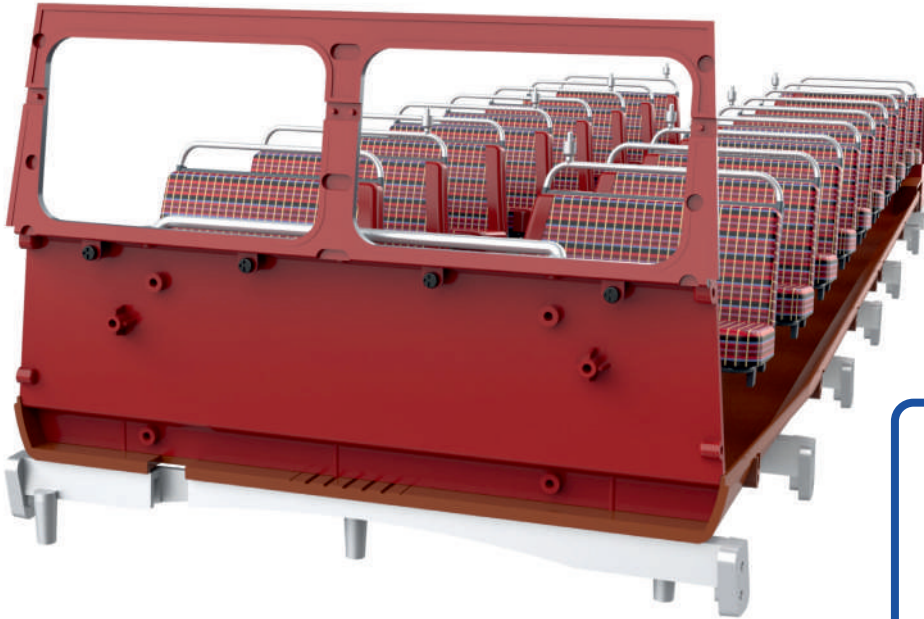

Store the rear wall carefully, as the grab pole can easily be snapped off.



STAGE 75

FRONT DESTINATION BLIND

The front destination blind, with a choice of route numbers and destinations, is fitted to the front of the bus.

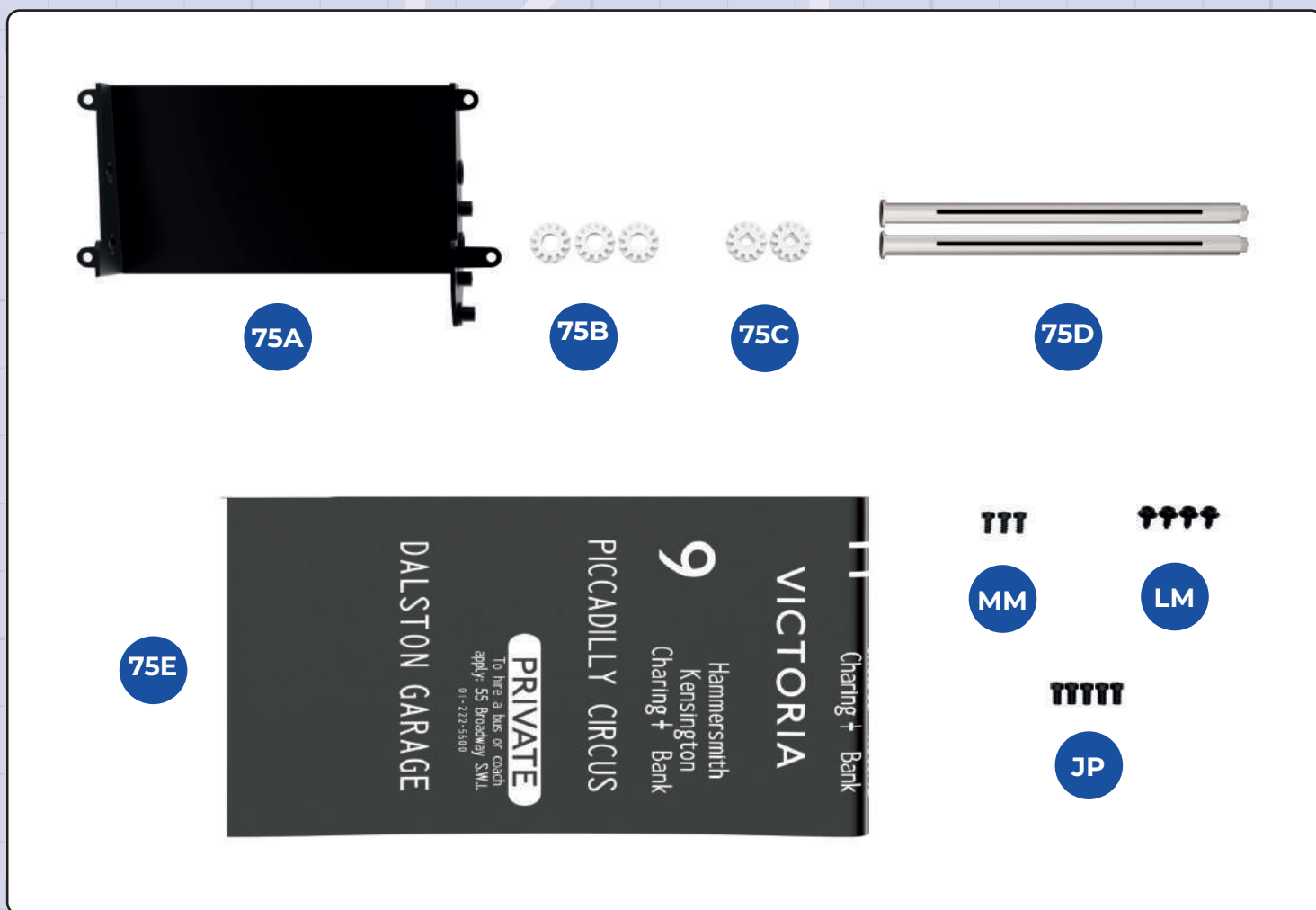

KEY TO PARTS SUPPLIED

75A	Frame	MM	2.0 x 4mm (x3)
75B	Cog (x3)	LM	2.0 x 4 x 5mm (x4)
75C	Cog (x2)	JP	2.3 x 4mm (x5)
75D	Roller (x2)		
75E	Blind		

 Note that cogs 75C have squared off holes, to fit over the shafts on the ends of the rollers.

1

Take one of the cogs **75B** and identify the fixing point on the side of the frame **75A**: the cog fits over the small raised screw socket. Fix in place with an **LM** screw.

2

Take the roller **75D** and slide the end with a shaft (circled in red) through the hole on one side of the frame **75A** and across to the other side of the frame.

3

The shaft at the end of the roller **75D** is close to the cog fitted in step 1. Take the second cog **75B** and fit it on to the second raised screw socket on the side of the frame **75A** (circled). Fix in place with an **LM** screw.

4

Take the first cog **75C** and fit it onto the shaft at the end of the roller **75D**, on the outer edge of the frame **75A**. Fix in place with an **MM** screw. **NOTE:** The toothed side of the cog faces towards the frame. The teeth will mesh with the cogs that have already been fitted. Hold the roller still with a pair of pliers while you fit the screw.

5

Take the third cog **75B** and fit it on to the raised screw socket at the end of the frame **75A** so that the teeth mesh with the cog fitted in step 3, as shown. Fix in place with an **LM** screw.

6

Peel the protective backing off the adhesive strip on the lower edge of the destination blind **75E**.

✓ Read step 7 and check the orientation of the frame and the destination blind before removing the protective backing from the adhesive strip.

7

Very carefully align the lower edge of the destination blind **75E** with the black line on the roller **75D**. Take your time to ensure the correct positioning and when you are happy that it is straight and central, stick the adhesive strip to the roller.

8

Identify cog **75C**, fitted in step 4. Using a screwdriver **MM**, rotate the screw that holds the cog in place. Turn in a clockwise direction so that the blind **75E** winds on to the roller **75D**.

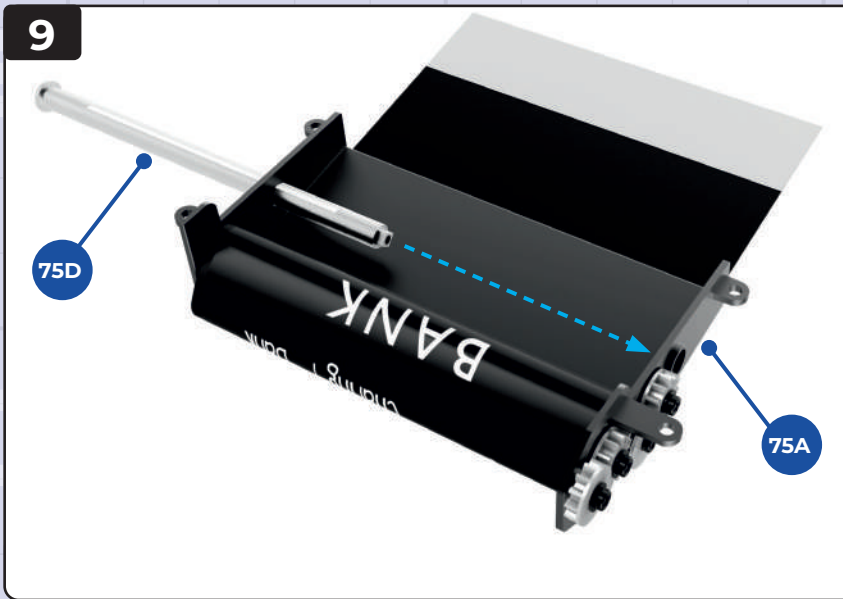

9 Take the second roller **75D**. As before, slide the end with a shaft through the frame **75A** and into the socket on the opposite side of the frame, beside the cogs that have been fitted. The inset shows the second roller in place.

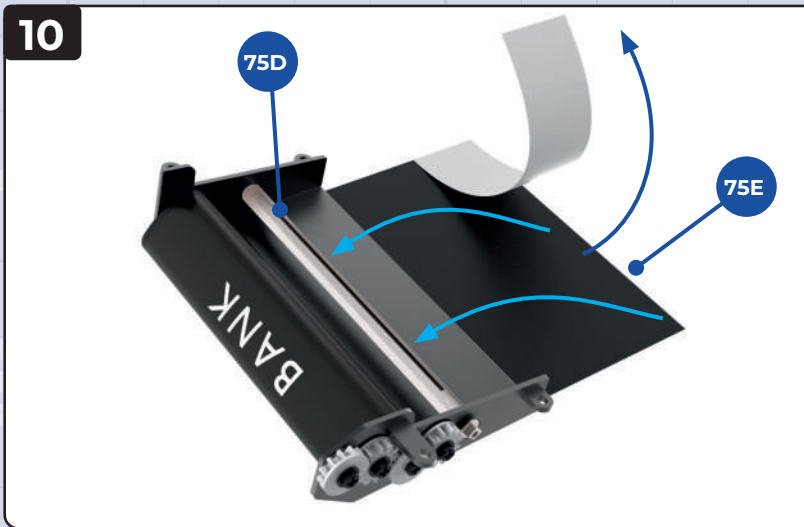

10 Peel the protective backing off the free end of the blind **75E**. Bring the lower edge of the blind up to align with the black line on the second roller **75D**. When it is accurately aligned, straight and central, fix the self-adhesive strip in place on the roller.

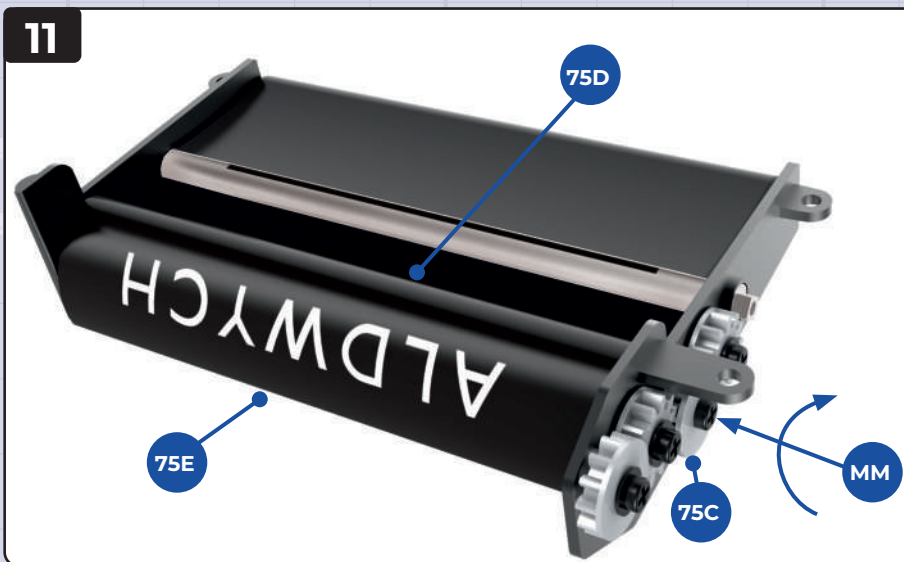

11 Using a screwdriver, as in step 8, continue to turn the **MM** screw that holds the first cog **75C** in place. Roll the blind **75E** on to the roller **75D**, leaving a very slight amount of slack in the blind (see step 12).

12

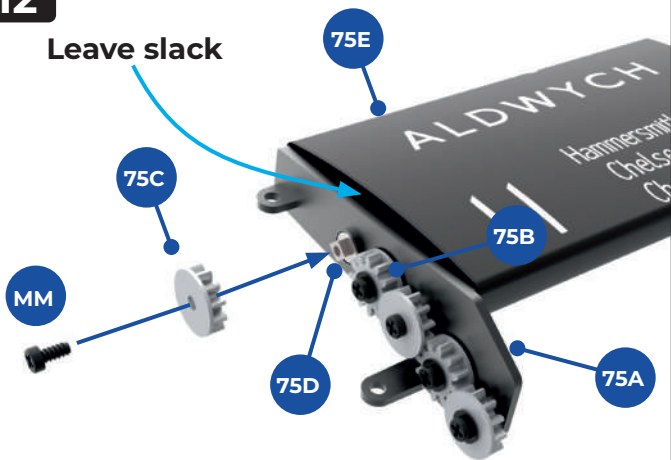

12 Leaving a little slack in the blind, as indicated, fit the second cog **75C** on to the end of the second roller **75D**. The teeth will mesh with the adjacent cog **75B**. Fix in place with an **MM** screw.

13

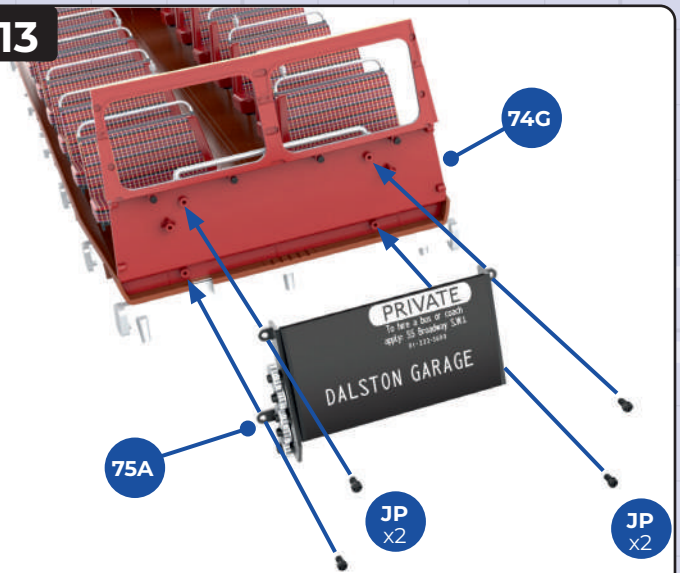

13 Align the screw holes in the tabs on the side of the frame **75A** with the sockets in part **74G** on the front of the upper deck. Fix in place with four **JP** screws.

Finished view



STAGE 76

DRIVER'S CAB DETAILS

In this stage, the ceiling of the driver's cab is supplied, together with levers and controls, which are fitted to the ceiling.

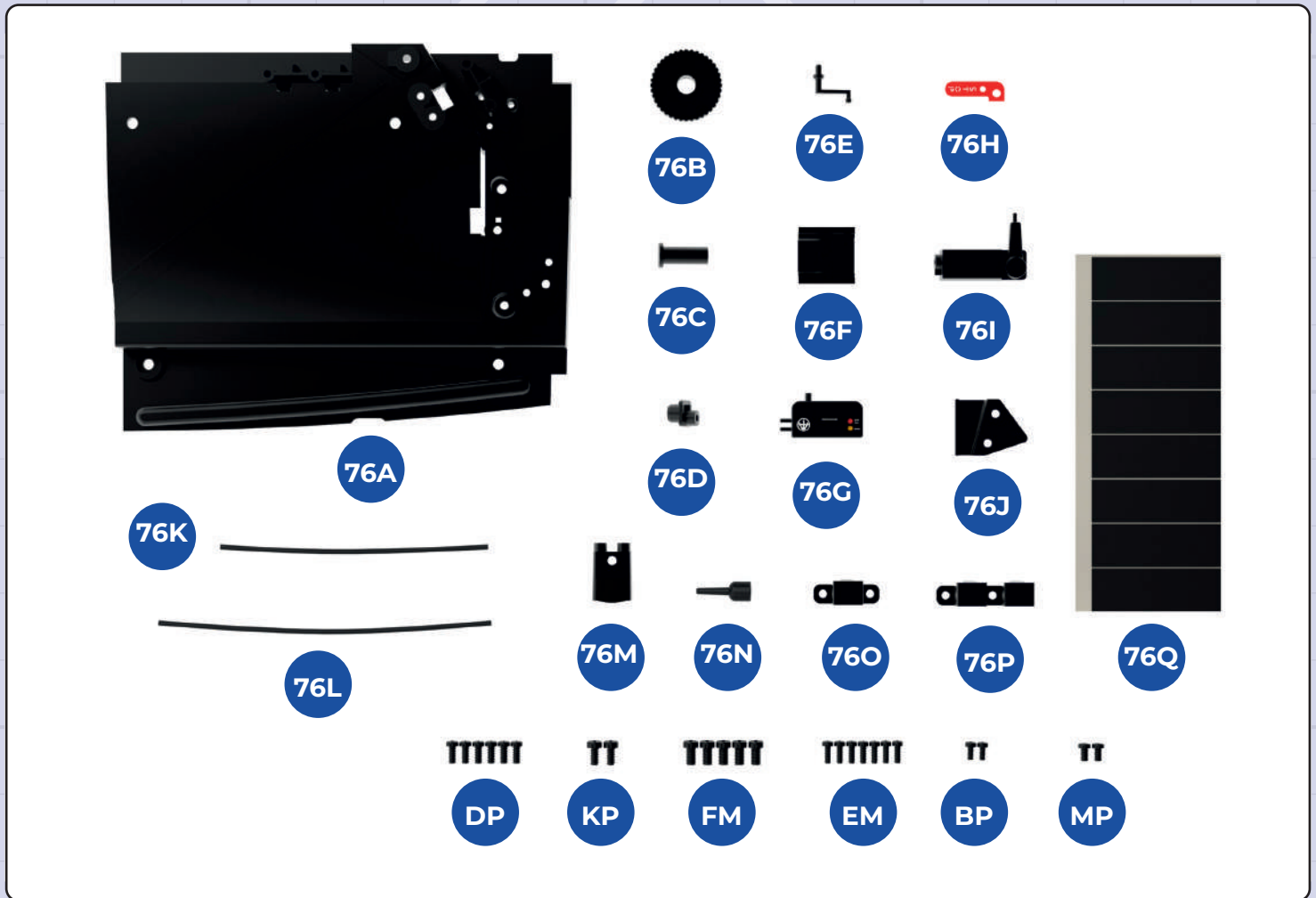

KEY TO PARTS

76A Driver's cab ceiling
76B Cog
76C Cog axle
76D Winder socket
76E Winder
76F Cover
76G Control box
76H Stop indicator
76I Distributor box

76J Bracket
76K Cable
76L Cable
76M Lamp housing
76N Extender knob
76O Single bracket
76P Double bracket
76Q Tape strips (x8)

DP 1.7 x 4mm (x6)
KP 2.0 x 4mm (x2)
FM 2.3 x 4mm (x5)
EM 1.5 x 4mm (x7)
BP 1.5 x 3mm (x2)
MP 1.7 x 3mm (x2)

✓ Some of the parts supplied with this stage will be used in the following stage. Store them carefully until they are needed.

1

Take the cover **76F** and check the orientation. There are ribs along two edges on one side, and two pegs on the other side. Fit the pegs into the holes in the driver's cab ceiling **76A** as shown.

2

Turn the roof over so that you can fix the cover in place using a DP screw.

3

Fit the cog **76B** over the matching hole in the upper side of the driver's cab ceiling **76A**. One side of the cog fits into the recess in the ceiling. Fit the stub axle **76C** through the centre of the cog to hold it in place. Turn the ceiling over (holding the stub axle in place) and fix the stub axle **76C** in place using a **KP** screw (inset right), taking care not to over tighten it.

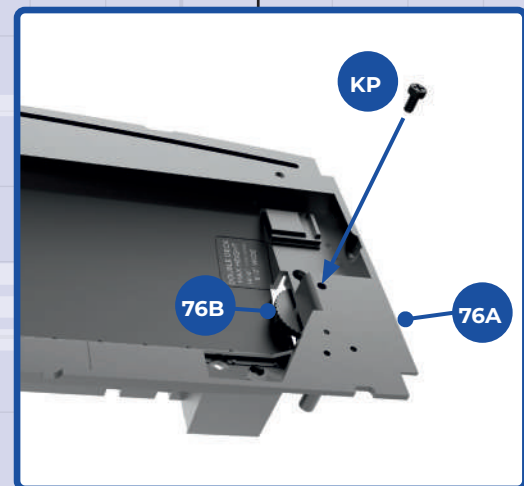

4

Take the stop indicator **76H** and fit it into the control box **76G** so that the large screw sockets are aligned and the peg in the control box fits into the hole in the stop lever, as indicated by the dotted line. Fix in place with a **BP** screw.

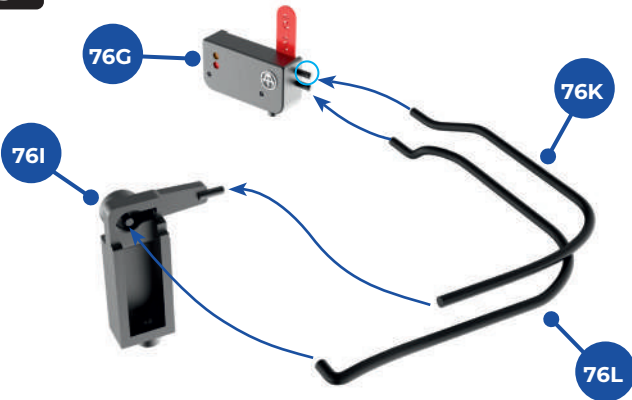
5

5 Take the two cables **76K** and **76L**. Note that **76L** is slightly longer. Fit one end of each cable onto the two pegs on the side of the control box **76G**. Note that **76K** goes on to the peg nearest to the stop indicator on the control box (circled). Fit the other end of cable **76K** on to the peg at the end of the arm on the distributor box **76I**. Fit the other end of cable **76L** onto the peg in the centre of the hub near the end of the distributor box **76I**.

✓ In these steps, for clarity we have shown the cables **76K** and **76L** shaped to fit around the edge of the assembly. The cables are actually straight.

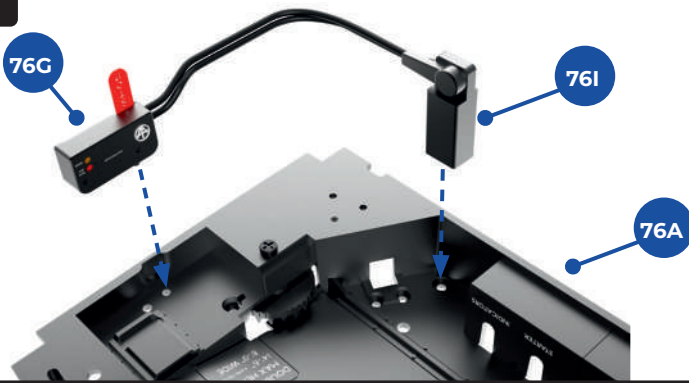
6

6 Take the ceiling of the driver's cab **76A** and place it upside down so that you can see the front corner as shown. Check the fit of the peg on the stop indicator control box **76G** in the hole at the front of the cab ceiling as indicated by the dotted line on the right in the diagram. Check the alignment of the raised screw socket on the distributor box **76I** with the screw socket at the side of the cab ceiling (dotted line on the left).

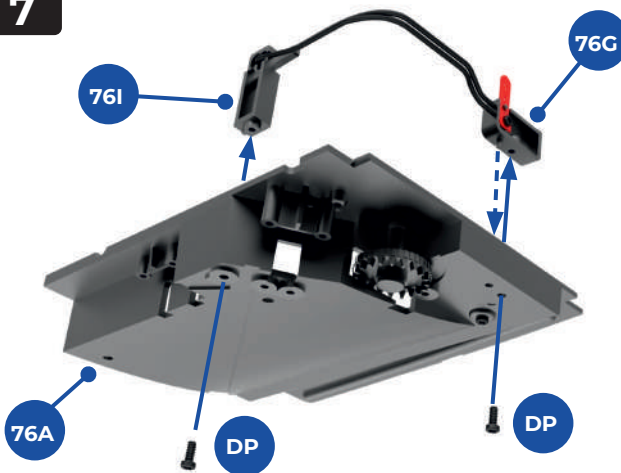
7

7 Fit parts **76I** and **76G** in place on the cab ceiling **76A** and fix in place with two **DP** screws. The two cables fit around the edge of the cab ceiling.

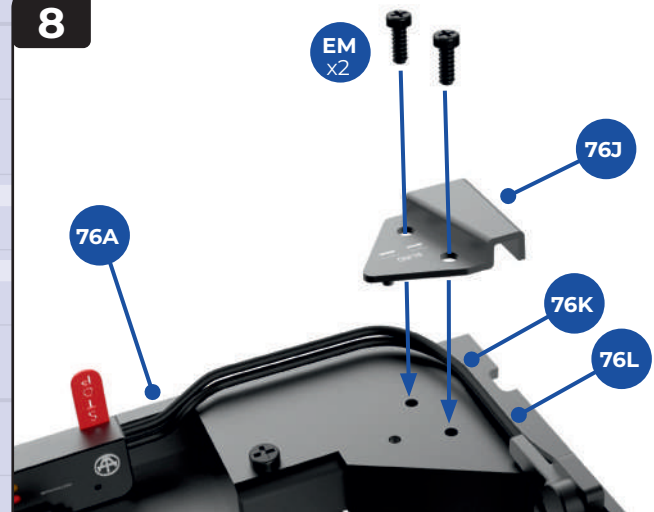
8

8 With the cables **76K** and **76L** arranged around the corner of the cab ceiling as shown, fit the bracket **76J** in place so that the cables run through the channel. Fix in place with two **EM** screws.

9

9 Fit the winder socket **76D** into the shaped hole in the cab ceiling **76A**, near the stop indicator. The locating peg on the underside of part **76D** fits into the shaped hole. Then fit the winder **76E** into the winder socket **76D**. Hold the winder and socket in place while you turn the ceiling over.

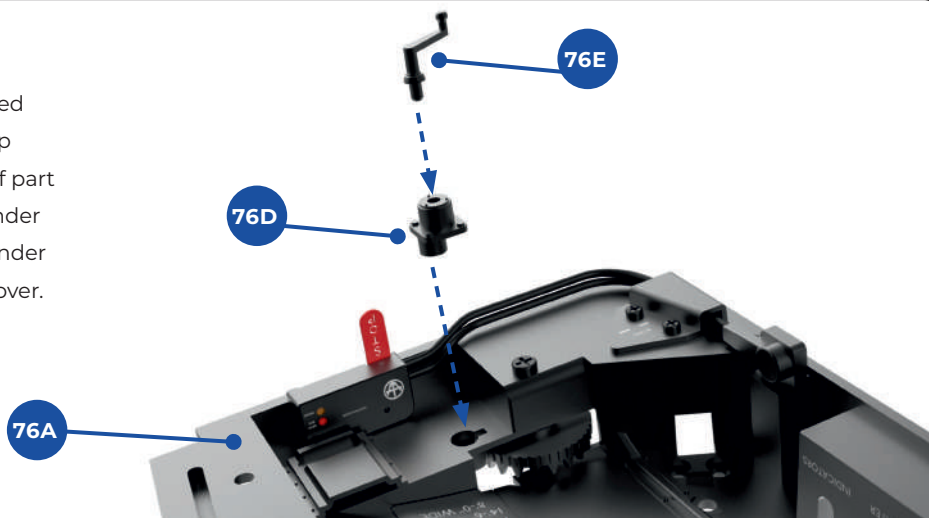

10

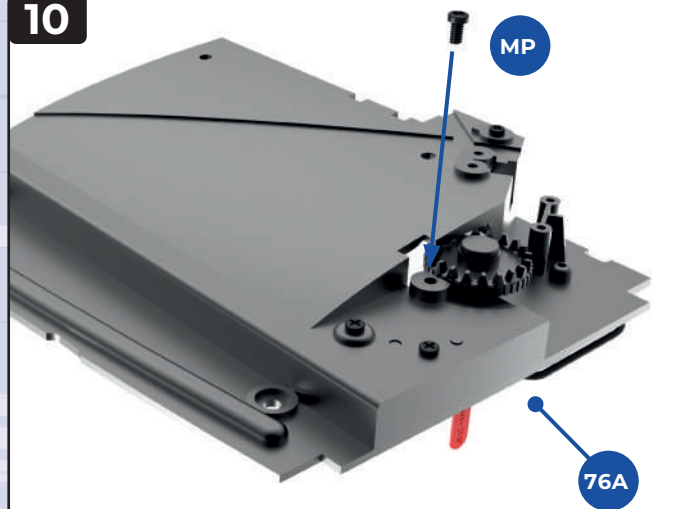

10 Fix the winder and socket in place from the top of the ceiling **76A** using an **MP** screw

11



11 Fit the two pegs on the lamp housing **76M** into the corresponding sockets in the ceiling of the driver's cab **76A**.

12

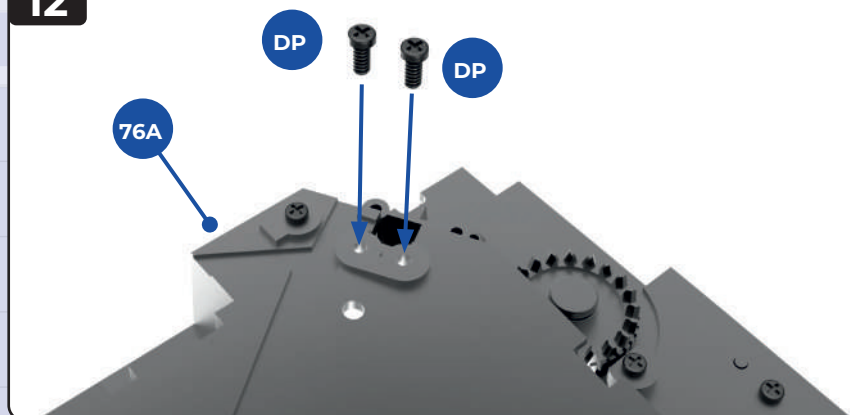

12 Hold the lamp housing **76M** in place while you turn the ceiling over. Fix the lamp housing in place using two **DP** screws.

Finished views

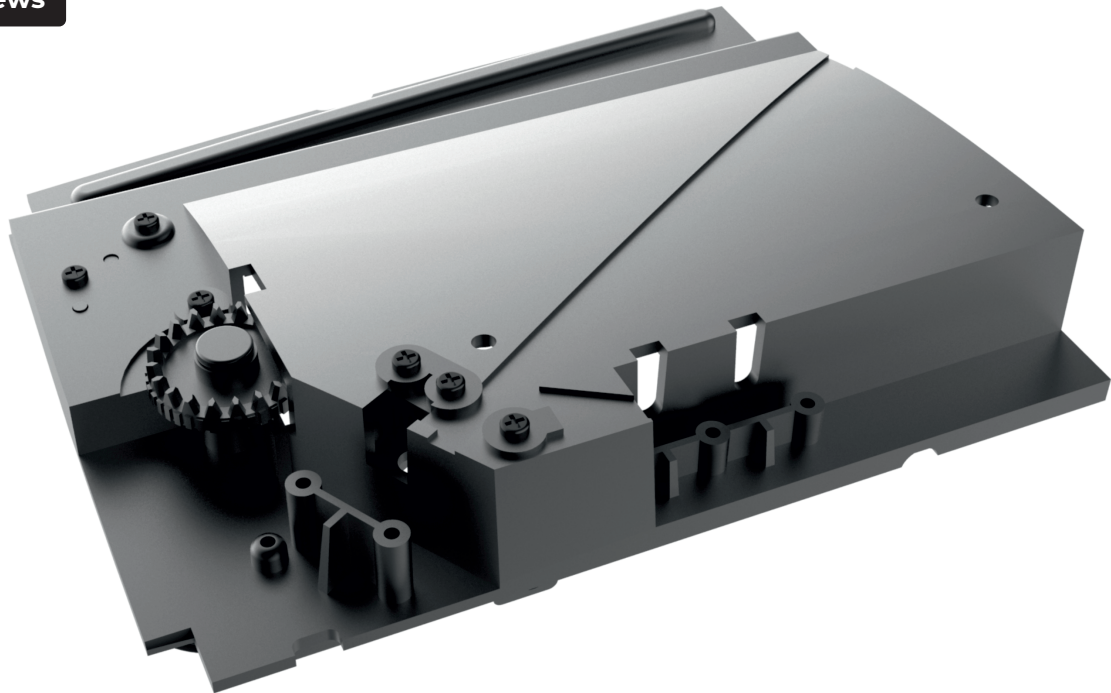

A cog and other accessories have been fitted to the ceiling of the driver's cab.



The parts supplied with this stage that have not yet been used will be fitted following the instructions in stage 77.

STAGE 77

ELECTRICS AND ROOF PANEL

The roof panel that fits above the bonnet next to the driver's cab is supplied, together with two handles. We re-arrange the electrical connections to add further fittings to the driver's cab.



KEY TO PARTS

- 77A** Roof panel
- 77B** Handle
- 77C** Circlip
- 77D** Handle

- FM** 2.3 x 4mm screws (x5)
- EM** 1.5 x 4mm red screws (x3)

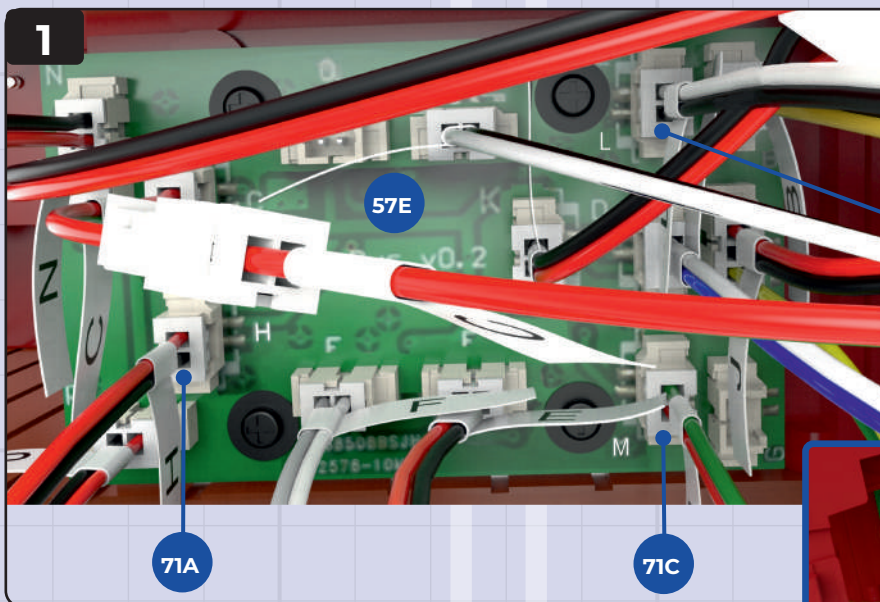

1 Unplug cable H **71A** (red and black), cable M **71C** (red and green) and cable L **71D** (black and white) from the circuit board **57E**. Disconnect cable J1 **71B** from cable J-J1 **55H** (inset below).

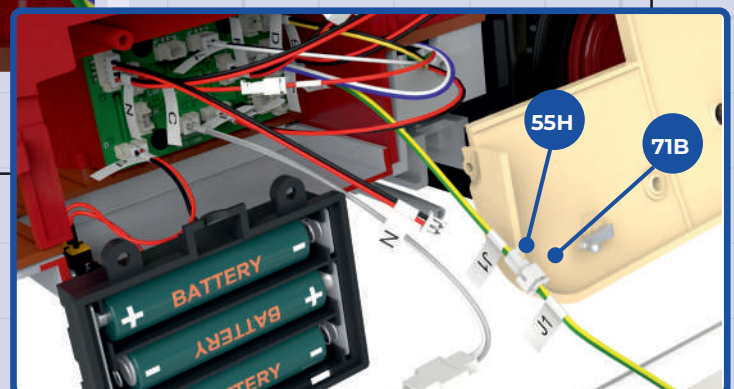

2

2 Take cable H **71A** (inset below). Fit the lamp on the end of the cable into the lamp housing **76M**, inserting it from the top of the ceiling of the driver's cab **76A**.

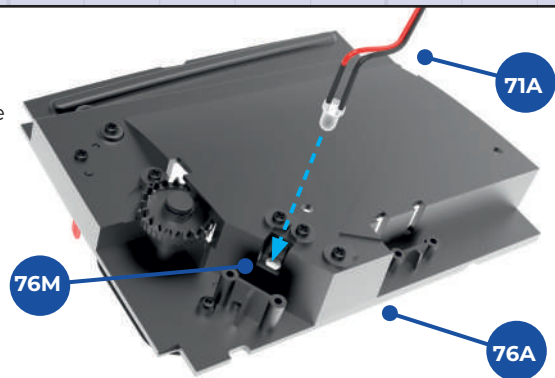
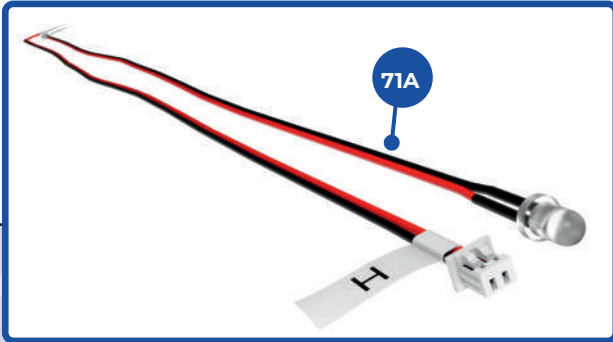

3

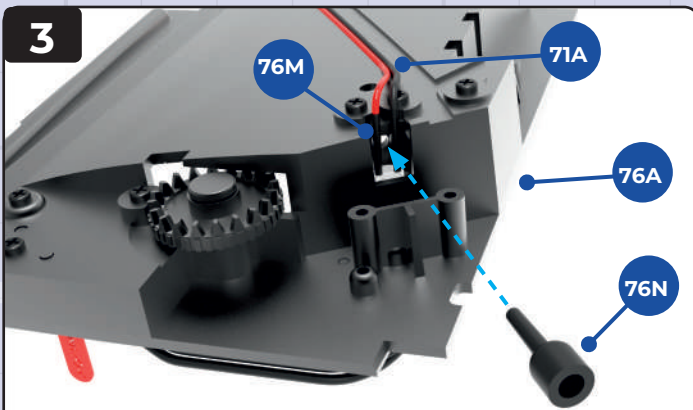

3 To anchor the lamp on cable **71A** in place, insert the peg of the extender knob **76N** between the black insulated parts of the cable **71A** and in to the hole in the lamp housing **76M**.

4

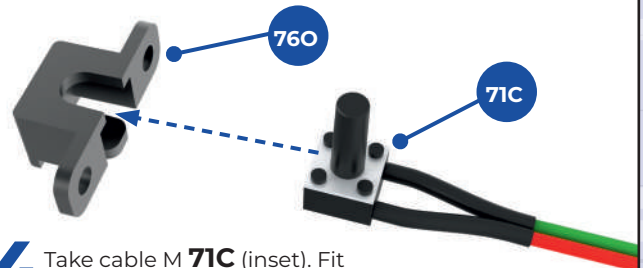
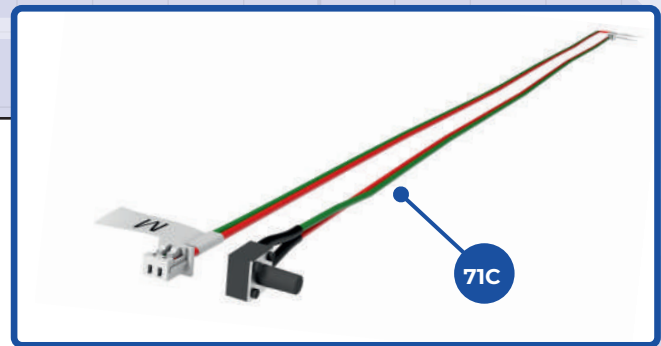

4 Take cable M **71C** (inset). Fit the switch at the end of the cable into the single bracket **760**.

5

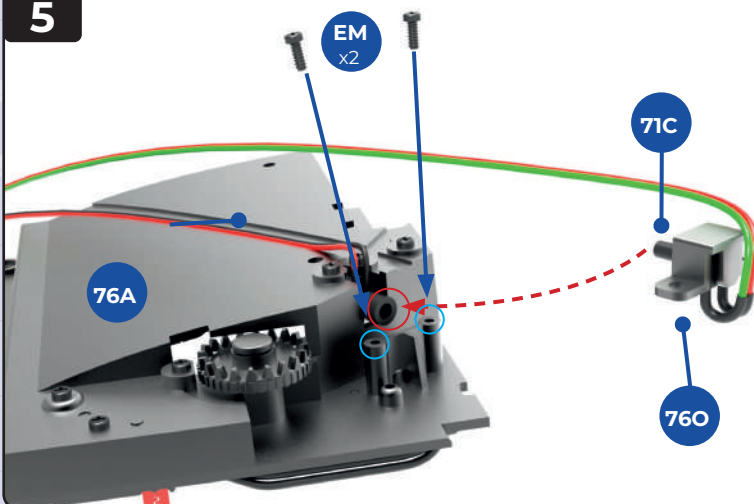

5 Fit the single bracket **760** on the driver's cab roof so that the screw holes on part **760** align with the screw sockets circled in light blue. At the same time, the switch on the end of cable **71C** fits into the extender knob **76N** (circled in red, as indicated by the red dotted line). Fix the bracket in place with two black **EM** screws, supplied with stage 76.

6

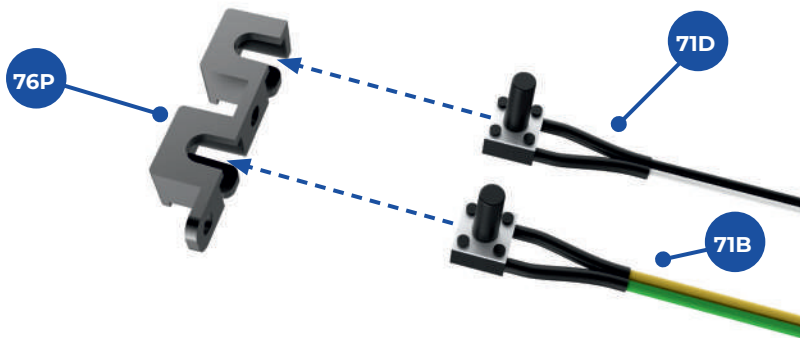

6 Take cables **71D** and **71B** (inset, right). Fit the switches on the ends of the cables into the double bracket **76P**. **NOTE:** The black and white cable is on the right and the green and yellow cable is on the left.



7

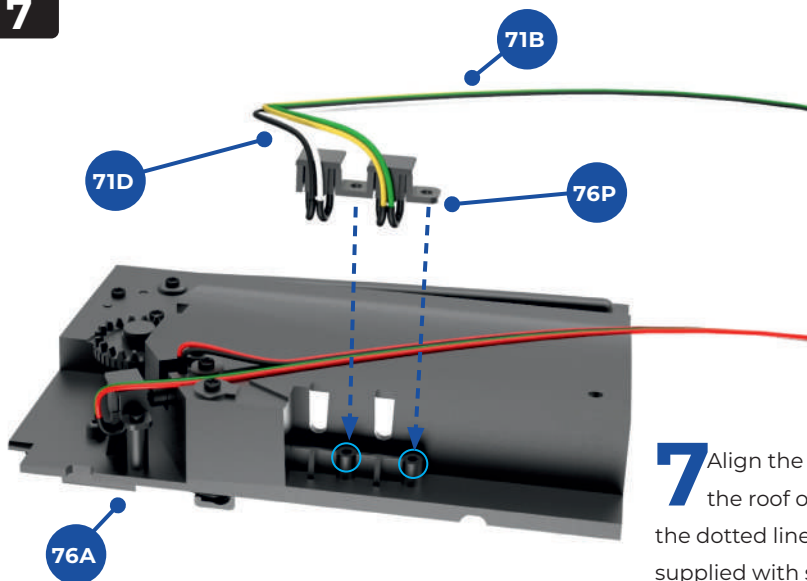

7 Align the screw holes on bracket **76P** with the screw sockets on the roof of the driver's cab (circled in light blue) as indicated by the dotted lines. Fix the bracket in place with two black **EM** screws, supplied with stage 76 (inset above).

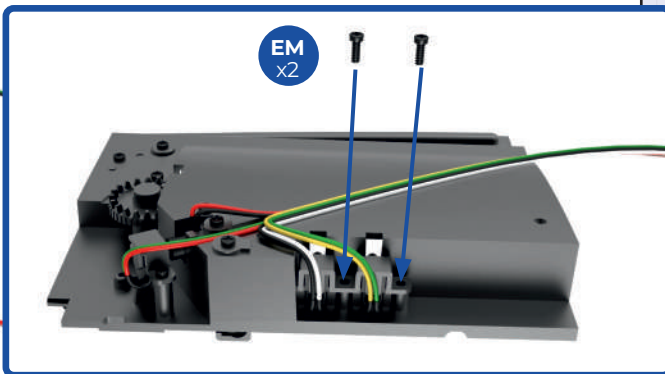

8

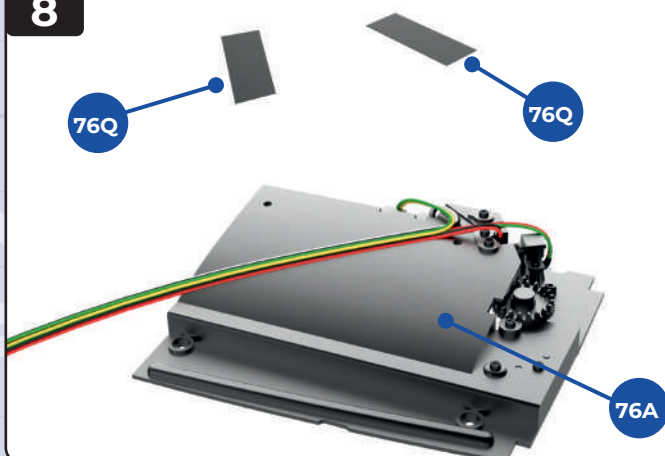

8 Run the cables **71A**, **71C**, **71D** and **71B** across the roof of the cab, fitting them into the groove. Fix in place with two stickers **76Q**.

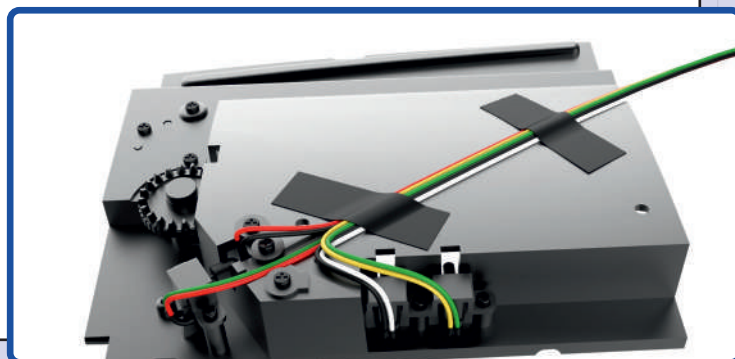

Take care to protect the fittings on the upper deck while you work.

9

9 Take the upper floor last worked on in stage 75 along with four **FM** screws supplied with the previous stage. Position the driver's cab ceiling **76A** in the front right-hand corner of the underside of the upper deck as shown, so that the screw sockets are aligned. **NOTE:** the cables fit into a notch in the cross strut of the frame **73A** (circled) as indicated by the red dotted line. Fix the ceiling in place with four **FM** screws.

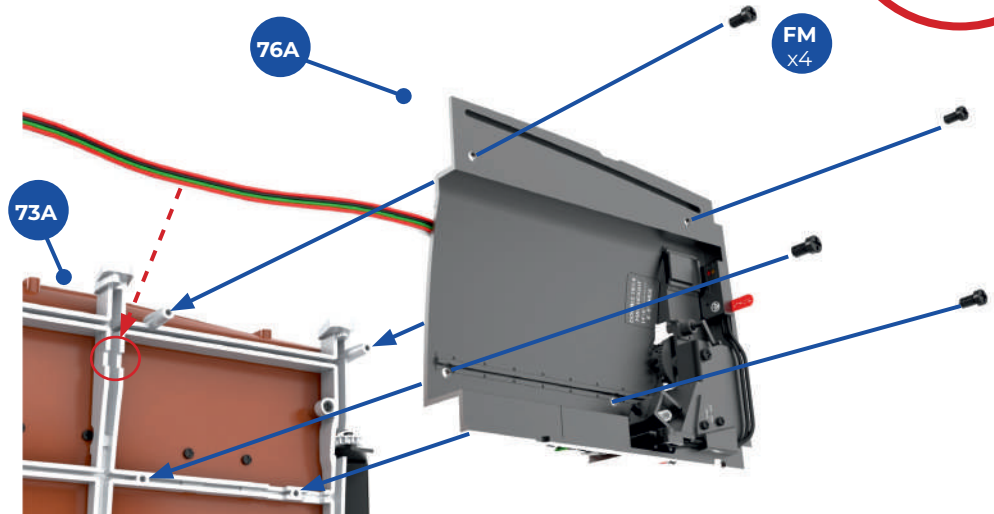

10

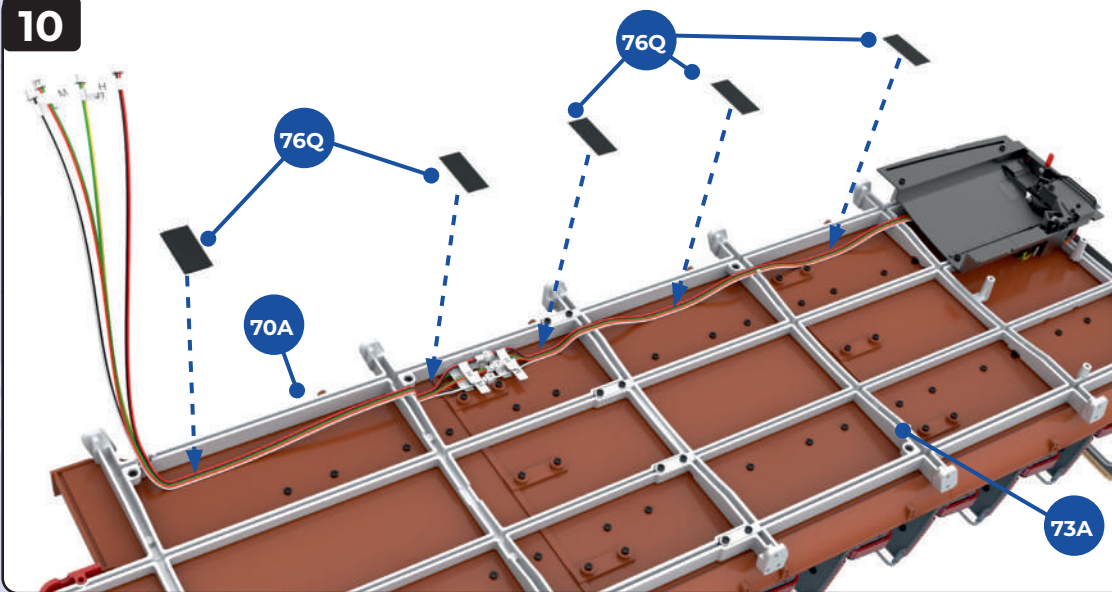

10 Continue to run the cables to the rear of the bus, so that they fit in the notches of the cross struts of frames **73A** and **70A**. Towards the back of the assembly, the cables fit into a notch in the longitudinal strut of frame **70A**. Use five pieces of sticky tape to hold the cables to the underside of the upper deck.

11

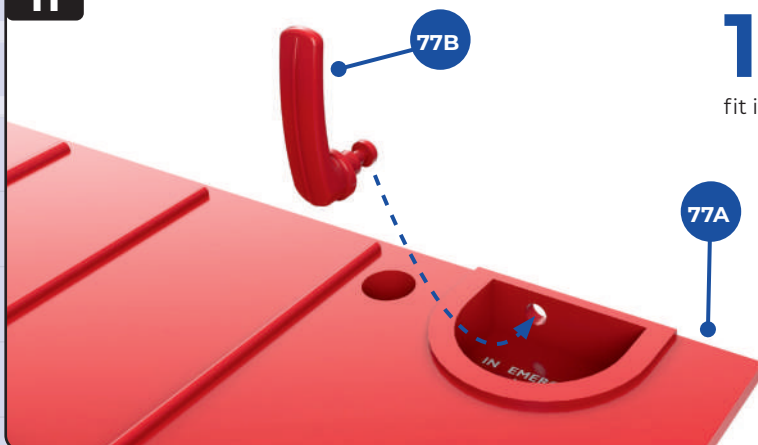

11 Fit the knob on the end of the handle **77B** through the hole in the recess in the roof panel **77A**. Take the circlip **77C** and fit it over the neck of the knob to anchor it in place (inset).

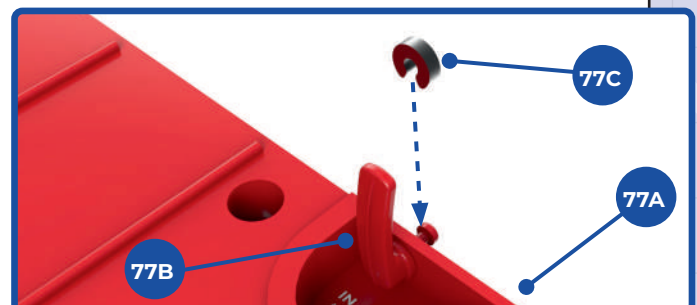

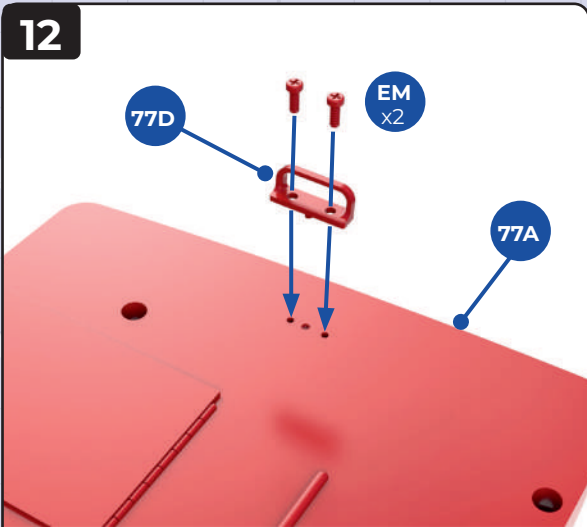

12 Position the handle **77D** at the side of the roof panel **77A** so that the locating pin fits in the central hole and the screw holes are aligned. Fix in place with two red **EM** screws.

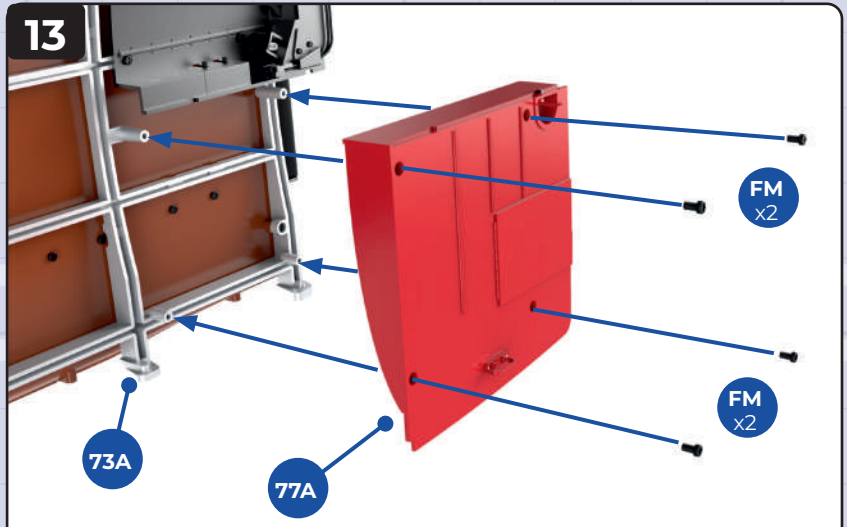

13 Position the roof panel on the underside of the upper floor, next to the ceiling of the driver's cab, as shown. Fix part **77A** to the frame **73A** using four **FM** screws supplied with this stage.

Finished views

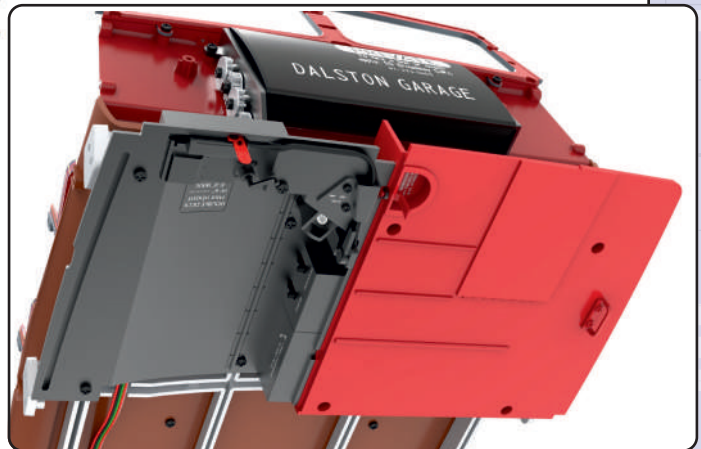
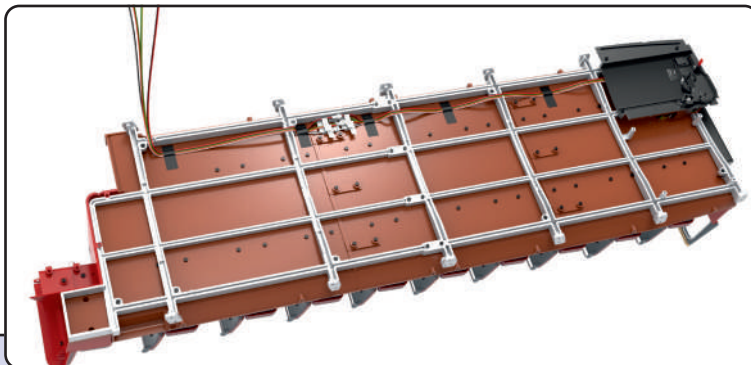
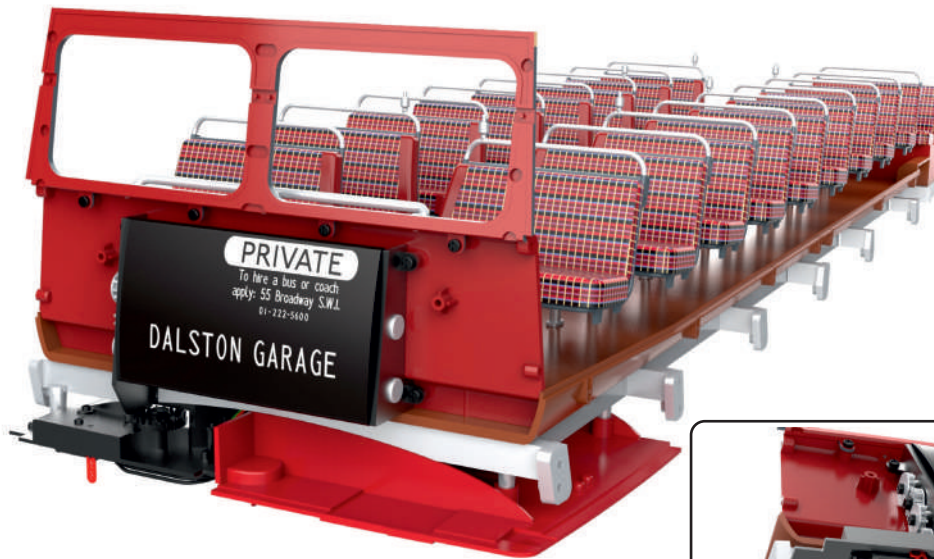

STAGE 78

INTERIOR UPPER DECK WALLS

The walls of the bus have inner and outer panels. Here we fit the inner panels on the left-hand side of the upper deck to the floor, and secure the seat frames in place.

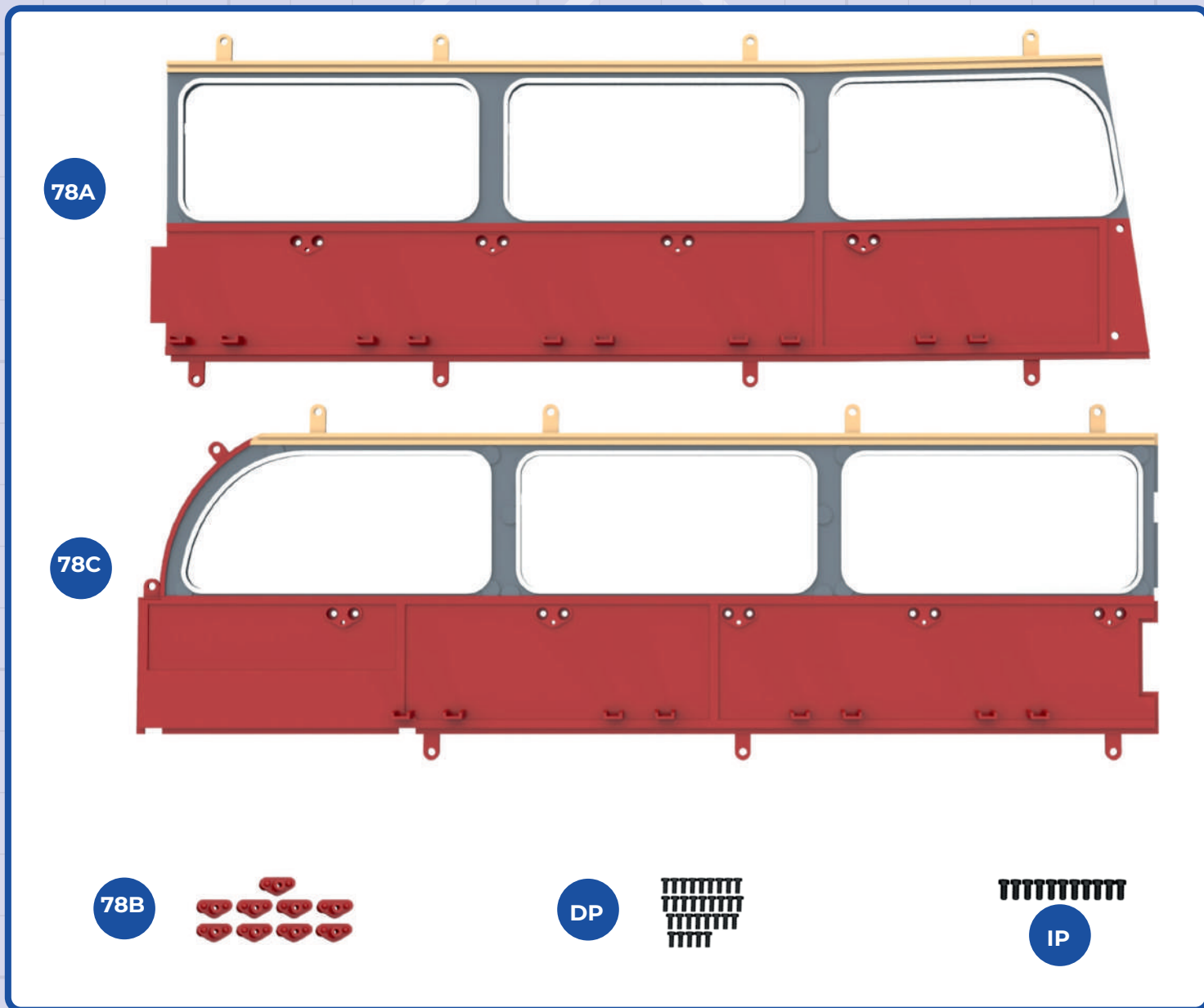

KEY TO PARTS

- | | | | |
|------------|--|-----------|-----------------|
| 78A | Left front inner side wall of upper deck | DP | 1.7 x 4mm (x31) |
| 78B | Seat fixture (x9) | IP | 2.3 x 5mm (x11) |
| 78C | Left back inner side wall of upper deck | | |

1

Take the front inner side wall **78A** and identify the inside (the diagram on the left shows the outer side of the wall). Take four of the seat fixtures **78B** and position them on the inside of the wall. Screw each one in place with two **DP** screws. The inset below shows the fixtures in place, viewed from the inside.

2

In the same way, take the rear section of the inner wall **78C**. Fix five seat fixtures **78B** to the inside of the wall panel using two **DP** screws for each fixture. The inset below shows the five seat fixtures in place.

3

3 Take the upper deck assembly from stage 77. Position the rear inner wall **78C** against the left side of the deck. The screw holes in the tabs at the base of part **78C** align with screw sockets at the edge of the floor, parts **68A** and **67A**. On the inside, the screw sockets at the ends of the seats will align with the seat fixtures **78B** fitted in step 2. Fix in place with three **IP** screws.

4

4 Starting with the rear seat frame, check that the screw hole in the tab on the back of the left seat frame **66E** is aligned with the seat fixture **78B**. Fix in place with a **DP** screw. Repeat along the next four seats to hold the left seat frames **64A** (x2) and **64B** (x2) in place (inset).

✓ When fitting the screws, you may find it easier if you use a fine file to enlarge the hole in the seat bracket slightly. This will clear away any remaining plastic from the manufacturing process.

5

5 If not already fitted, fit the front wall panel **74G** in place, as described in stage 74, step 6. Fit the front left wall panel **78A** in place. Note that at the rear edge, there are tabs that interlock with recesses on part **78C** (circled in light blue). The screw holes in the tabs at the base of part **78A** align with screw sockets at the edge of the floor, parts **69A** and **68A**. Two screw sockets at the front edge align with sockets in the front wall **74G**. Fix part **78A** in place with six **IP** screws.

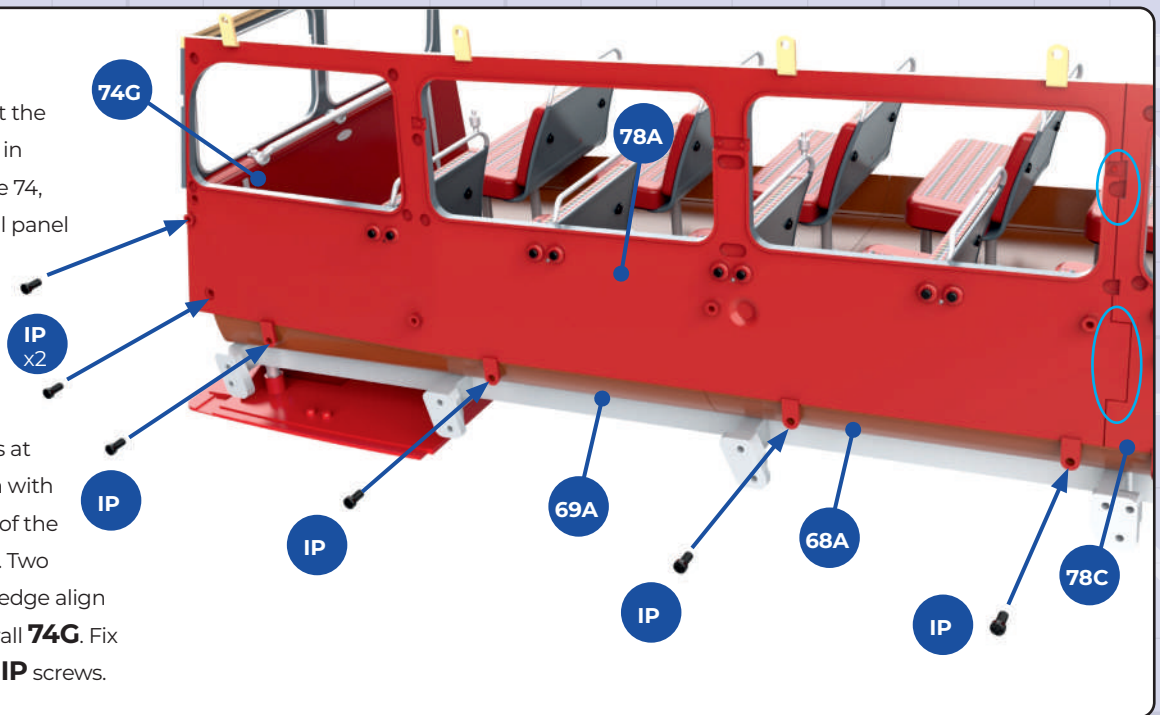

6

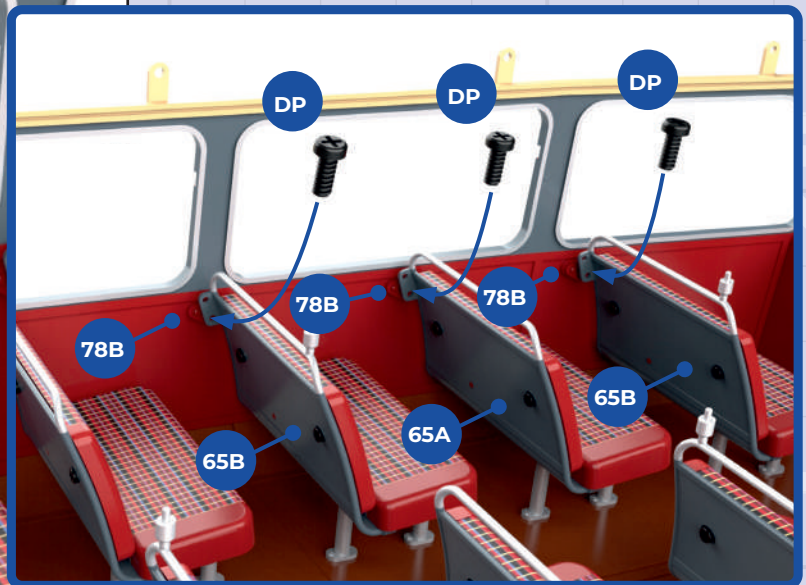
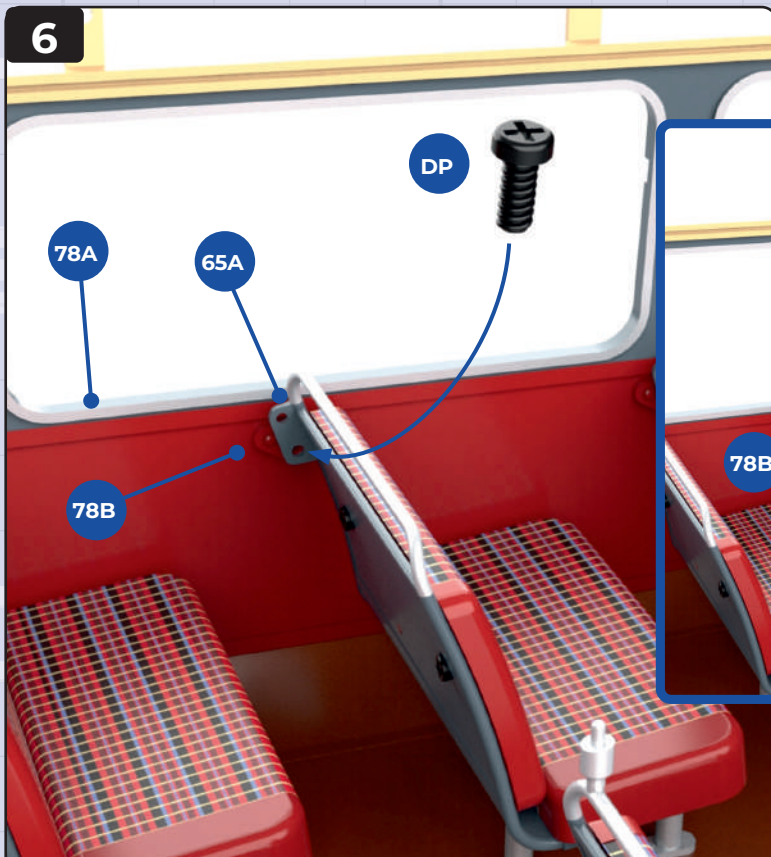

6 As described in step 4, fix the next seat frame (**65A**) in place using a **DP** screw. Fit each of the remaining seat frames (2 x **65B** and **65A**) in place using a **DP** screw (inset).

Finished views



STAGE 79

INTERIOR UPPER DECK WALLS

In a similar way to the previous stage, we fit the inner panels on the right-hand side of the upper deck to the floor, and secure the seat frames in place.

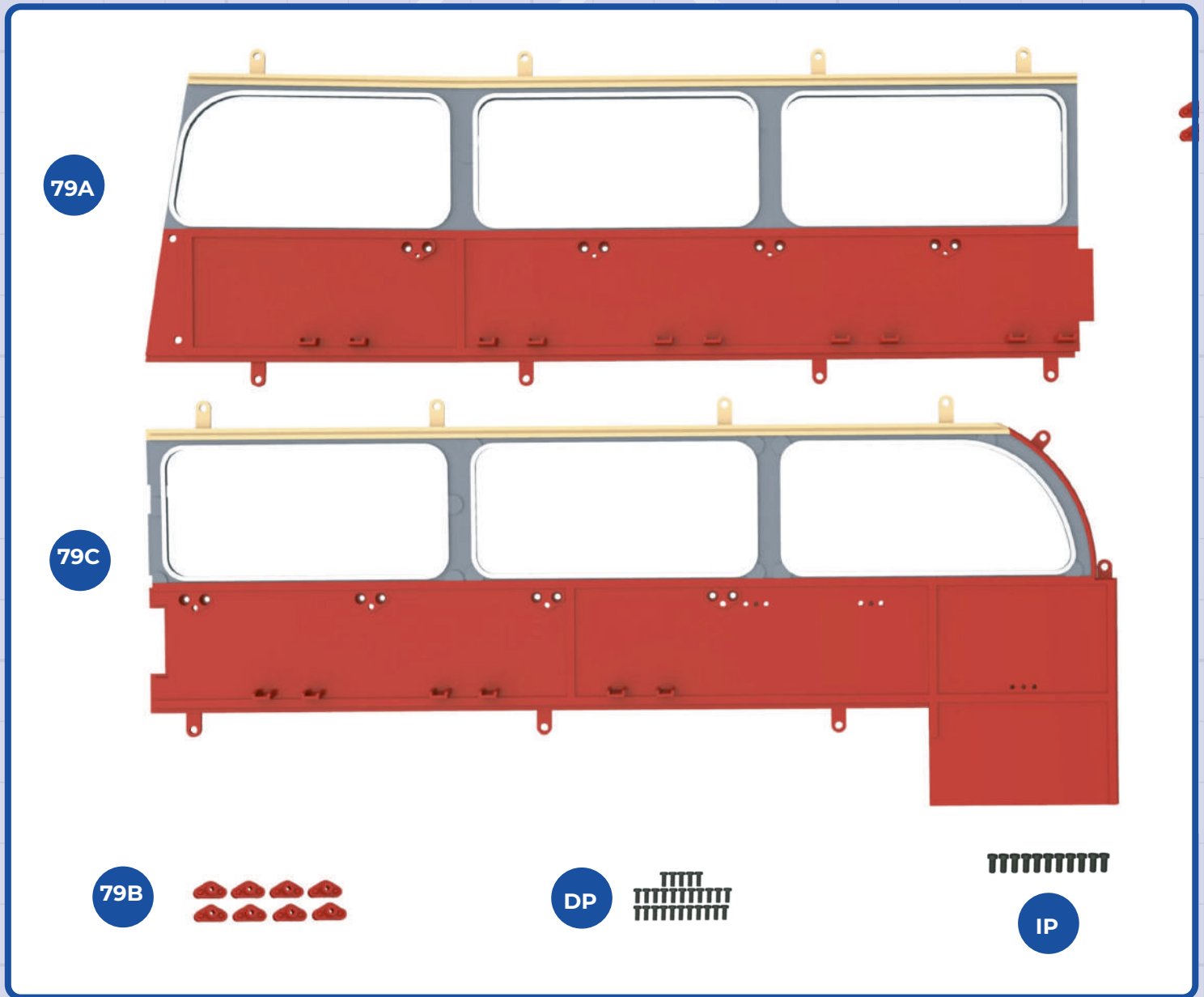

KEY TO PARTS

79A	Right front inner side wall of upper deck	DP	1.7 x 4mm (x27)
79B	Seat fixture (x8)	IP	2.3 x 5mm (x11)
79C	Right back inner side wall of upper deck		

1

1 Take the rear inner side wall **79C** and identify the inside (the diagram on the left shows the outer side of the wall). Take four of the seat fixtures **79B** and position them on the inside of the wall. Screw each one in place with two **DP** screws. The inset below shows the fixtures in place, viewed from the inside.

2

2 In the same way, take the front section of the inner wall **79A**. Fix four seat fixtures **79B** to the inside of the wall panel using two **DP** screws for each fixture. The inset below shows the four seat fixtures in place.

3

3 Take the upper deck assembly from stage 78. Position the front inner wall **79A** against the right side of the deck. The screw holes in the tabs at the base of part **79C** align with screw sockets at the edge of the floor, parts **68A** and **69A**. At the front, two screw holes align with holes in the lower part of the front of the bus, part **74G**. On the inside, the screw sockets at the ends of the seats will align with the seat fixtures **79B** fitted in step 2. Fix in place with six **IP** screws.

4

4 Fit the rear right wall panel **79C** in place. Note that at the front edge, there are recesses that interlock with tabs on part **79A** (circled in light blue). The screw holes in the tabs at the base of part **79C** align with screw sockets at the edge of the floor, parts **67A** and **68A**. Fix part **79C** in place with three **IP** screws.

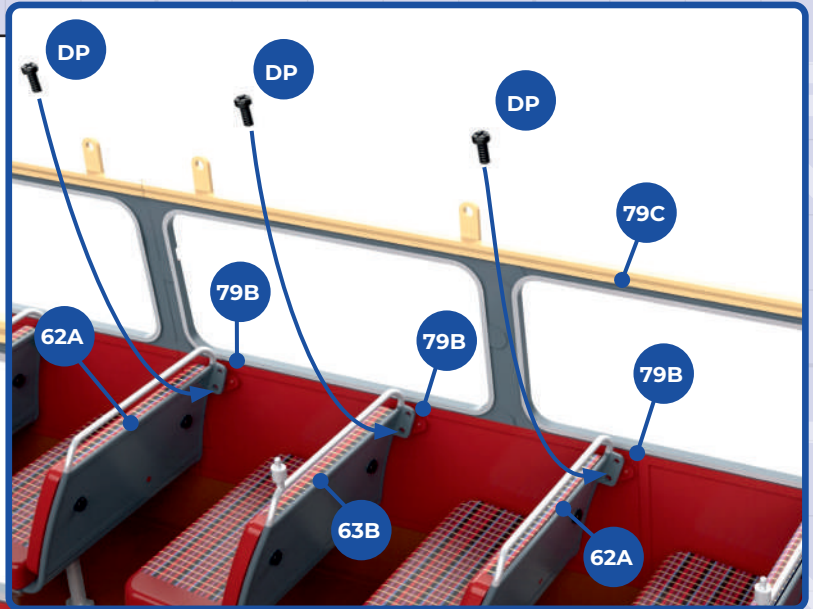
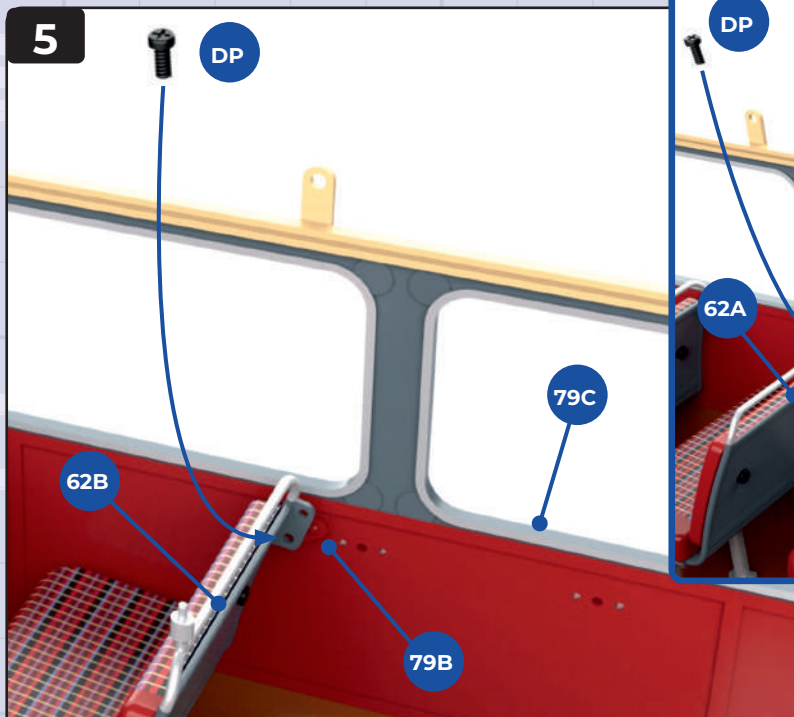

5 Starting with the rear seat frame, align the screw hole in the tab on the back of the seat frame **62B** with the seat fixture **79B**. Fix in place with a **DP** screw. Repeat along the next four seats to hold the right seat frames **62A** (x2) and **63B** in place (inset).

 When fitting the screws, you may find it easier if you use a fine file to enlarge the hole in the seat bracket slightly. This will clear away any remaining plastic from the manufacturing process.

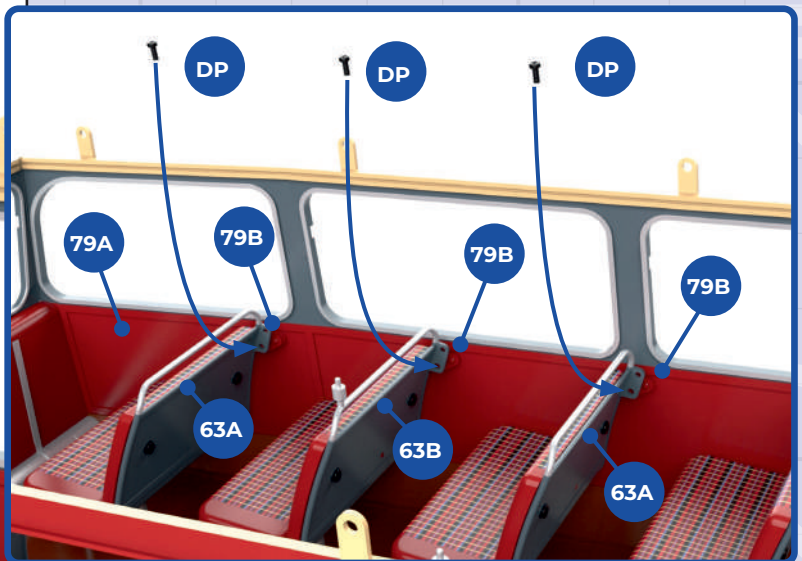
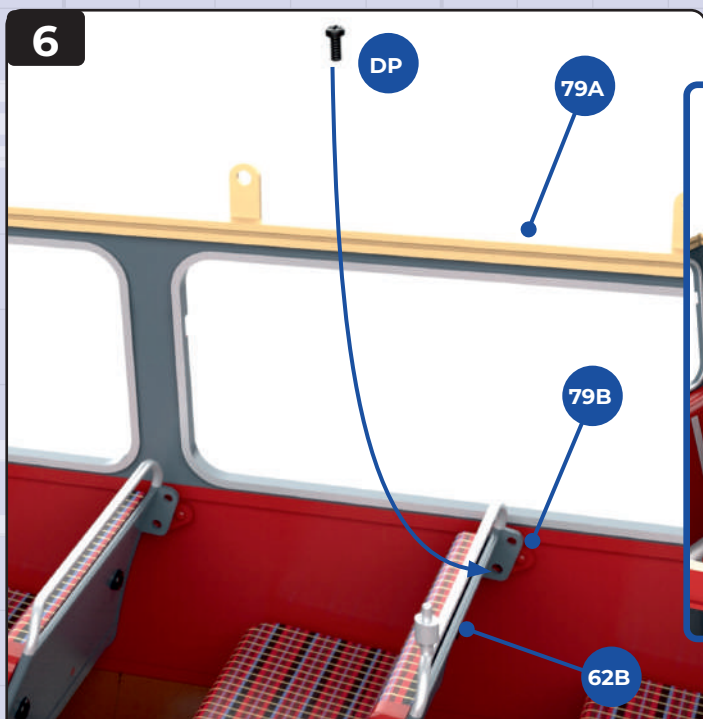

6 Continue to the front of the bus fixing the next seat frame (**62B**) in place using a **DP** screw. Fit each of the remaining seat frames (2 x **63A** and **63B**) in place using a **DP** screw (inset).

Finished views

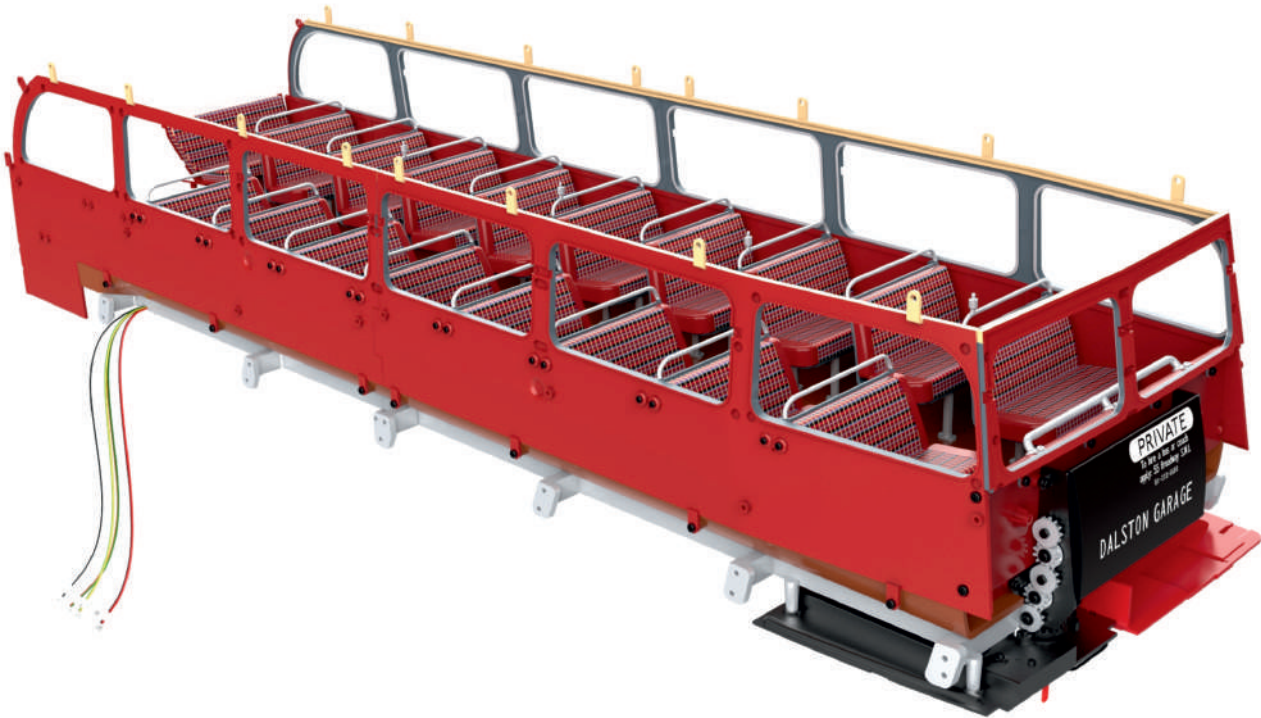
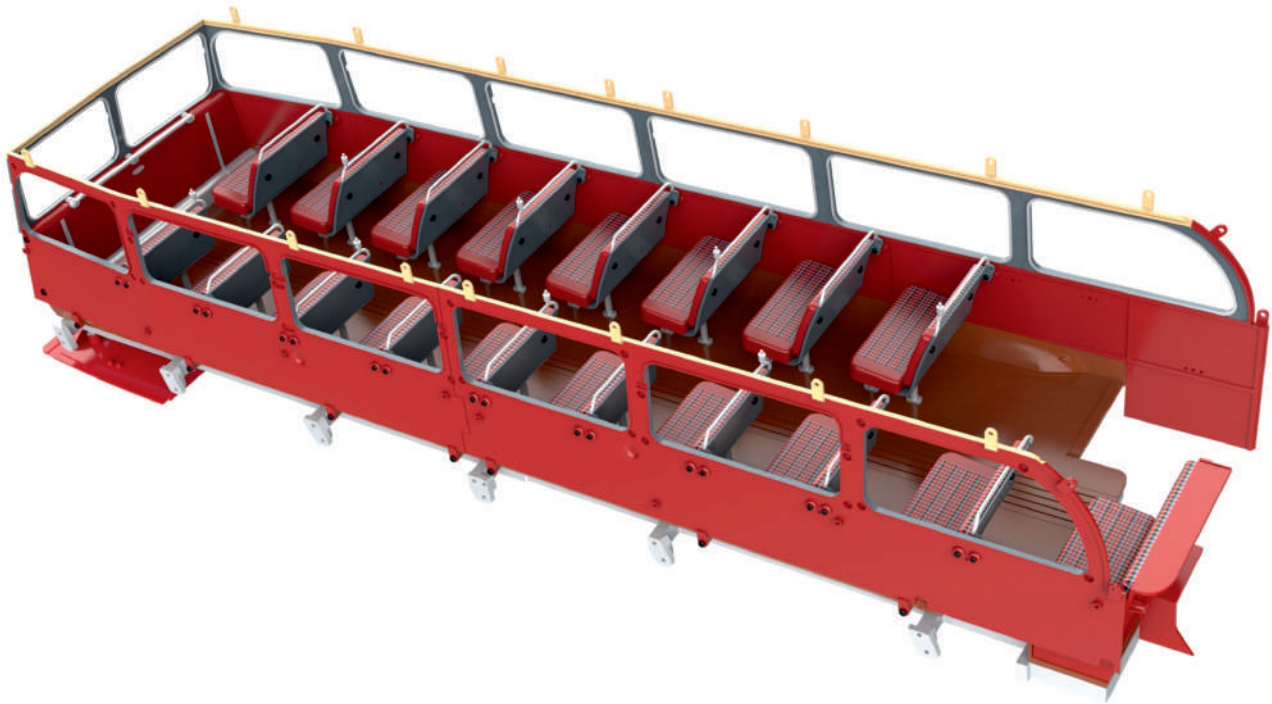

STAGE 80

FRONT WINDOWS AND ELECTRICS

We start work on the front windows and the frame for the front blind. We also add extender cables to the electrics for the lights and bell/buzzer sound.

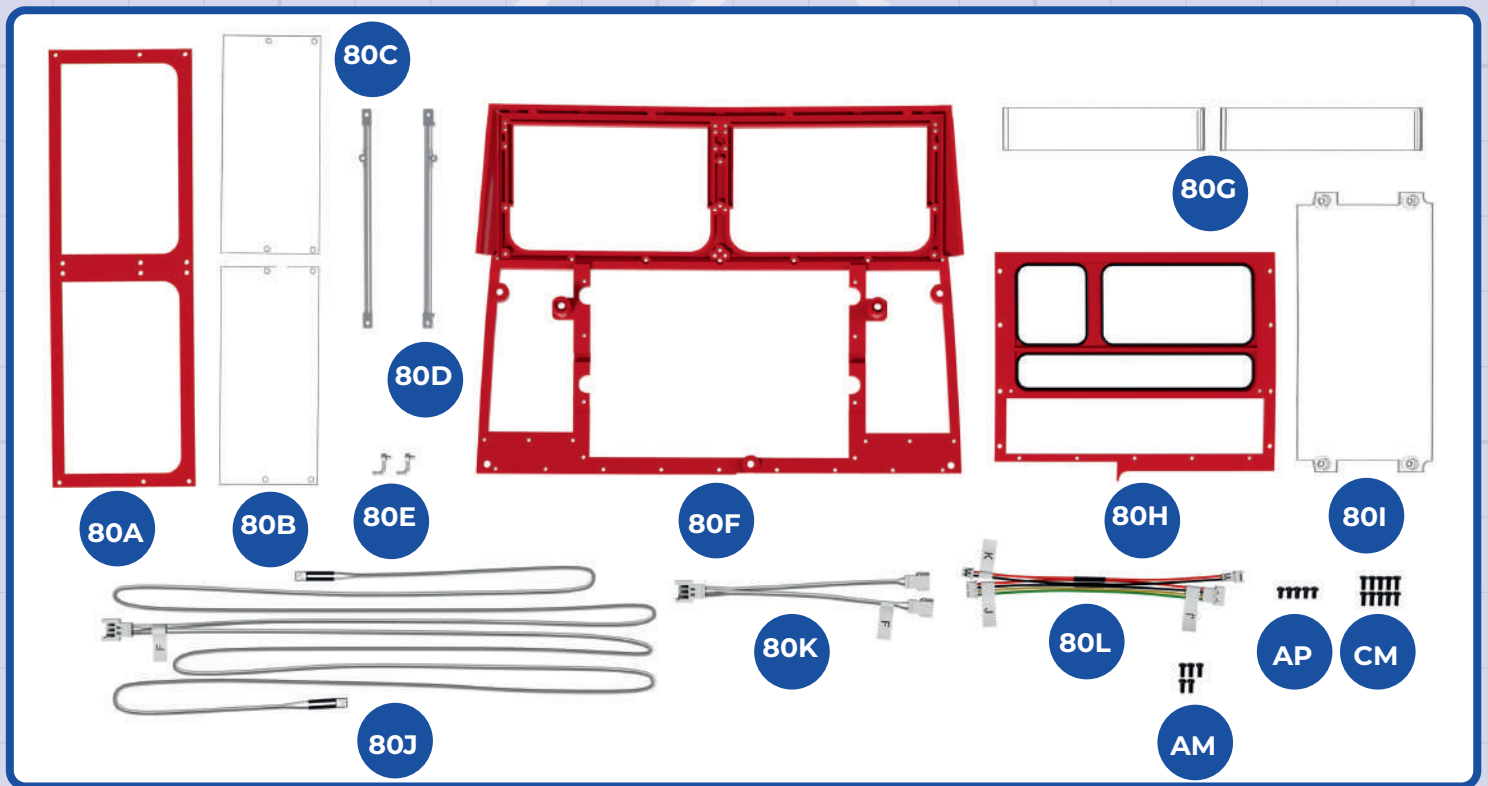

KEY TO PARTS

- 80A** Inner front window frame
- 80B** Window panes (x2)
- 80C** Left bar
- 80D** Right bar
- 80E** Window winders (x2)

- 80F** Front frame
- 80G** Wind-down windows (x2)
- 80H** Front blind frame
- 80I** Pane
- 80J** Cable F (grey-white)
- 80K** Extender cable F (grey-white)

- 80L** Extender cable JK (green-yellow-black-red)
- AP** 1.7 x 3mm (x5)
- CM** 1.7 x 4mm (x10)
- AM** 1.7 x 3mm (x5)

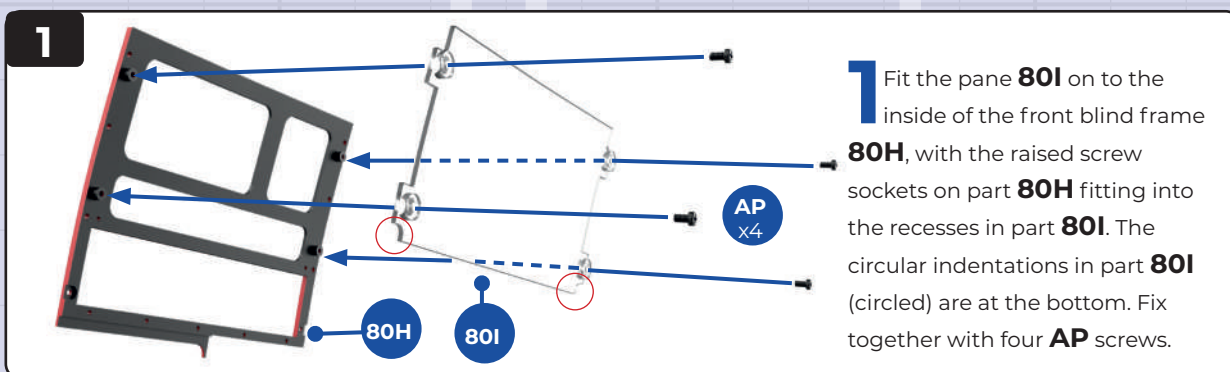

1 Fit the pane **80I** on to the inside of the front blind frame **80H**, with the raised screw sockets on part **80H** fitting into the recesses in part **80I**. The circular indentations in part **80I** (circled) are at the bottom. Fix together with four **AP** screws.

✓ When working on the electrics, always turn off the power before connecting or disconnecting cables.

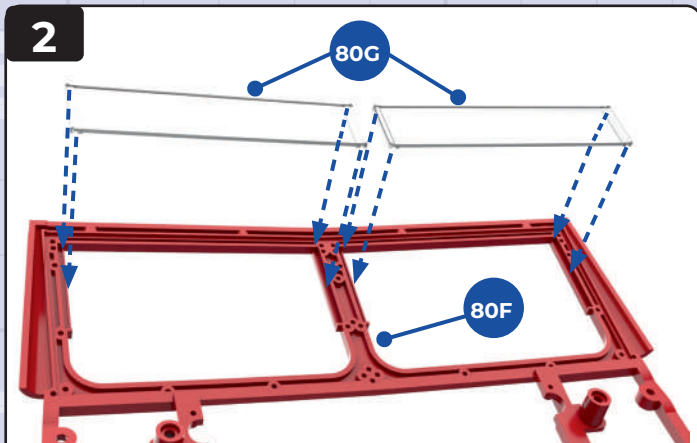

2 Take the front frame **80F**. Fit the shaped ends of the wind-down windows **80G** into the grooves in part **80F**, ensuring parts **80G** are at the top of the window openings, with the long 'metal' edge at the top.

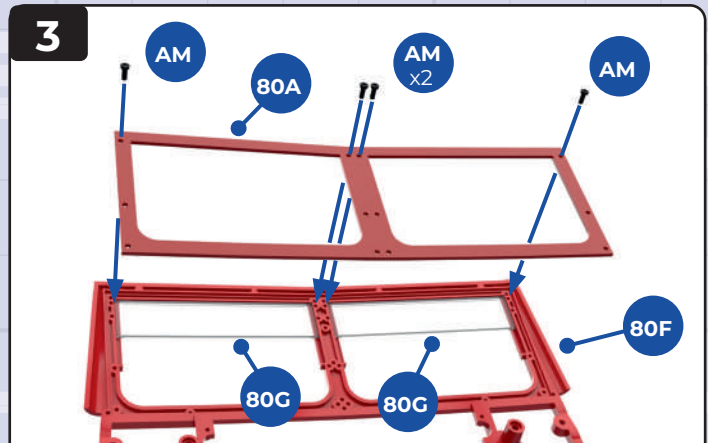

3 Fit the inner front window frame **80A** on the inside of the front frame **80F** enclosing the wind-down windows **80G**. The gloss finish of part **80A** is facing away from you in this diagram. Fix together with four **AM** screws.

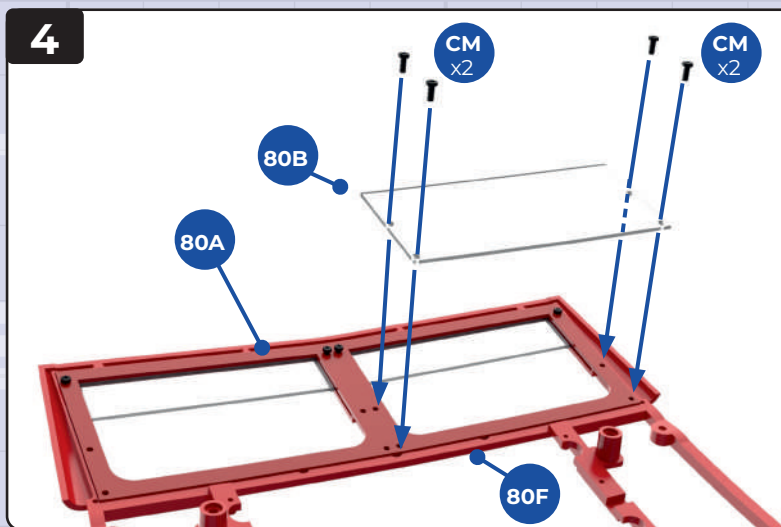

4 Fit one of the window panes **80B** on the inside of the window frame **80A**. Fix in place with four **CM** screws. Repeat to fit the second window pane **80B** (inset above).

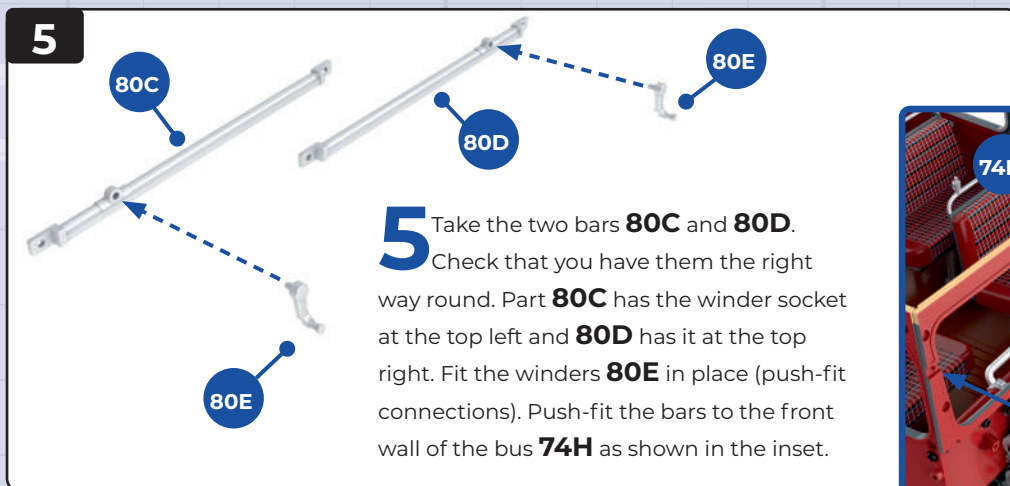

5 Take the two bars **80C** and **80D**. Check that you have them the right way round. Part **80C** has the winder socket at the top left and **80D** has it at the top right. Fit the winders **80E** in place (push-fit connections). Push-fit the bars to the front wall of the bus **74H** as shown in the inset.

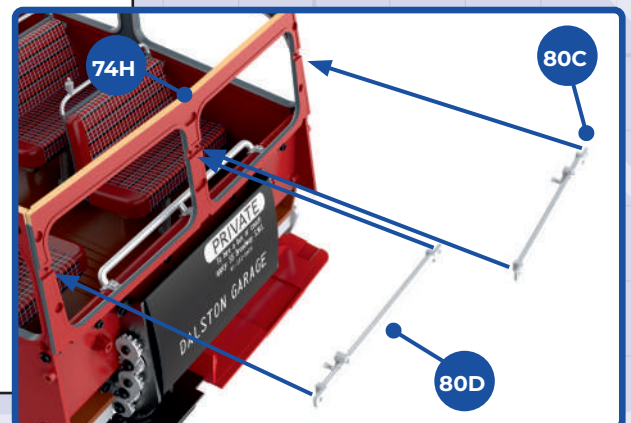

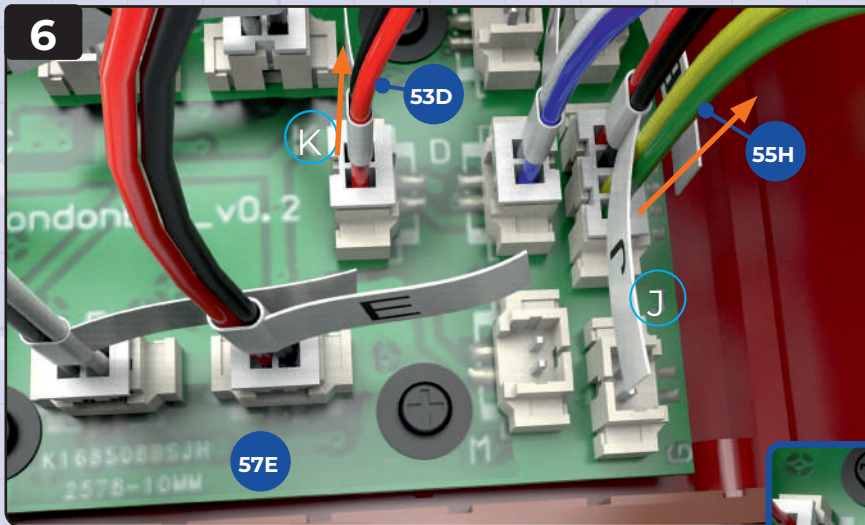

6 At present, pushing the 'bell' buttons on the platform gives a buzzer sound. To change this to a bell sound (the same as the cord pull) an additional cable needs to be fitted. On the circuit board **57E**, disconnect cable **J (55H)**, green-yellow-black-red) and cable **K (53D)**, red-black). Plug the green-yellow-black-red extender cable supplied with this stage (**80L**) into socket **J** on the circuit board **57E**. Leave socket **K** unplugged (inset below).

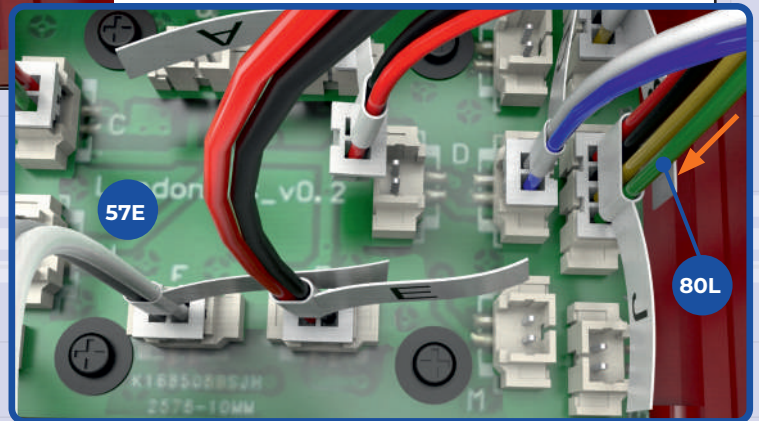

7 Identify the two sockets on the end of extender cable **JK (80L)**. Take the sockets on the end of cable **K (53D)** and cable **J (55H)**, which were unplugged in step 6, and plug them into the respective sockets of extender cable **JK (80L)**. The inset shows the arrangement from a different angle.

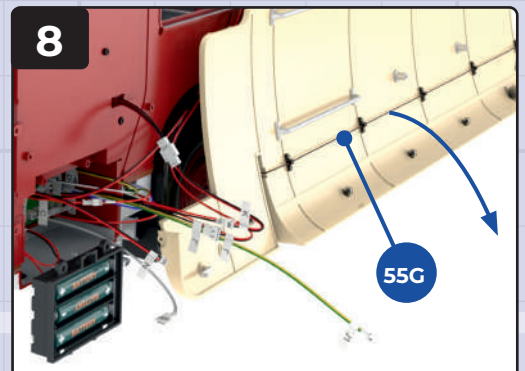
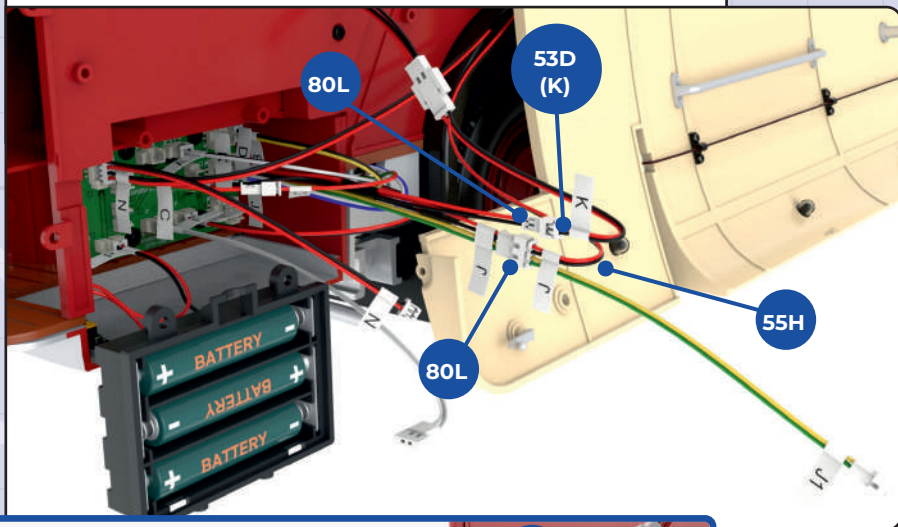

8 Test that the bells work by pulling the cord on the ceiling of the lower deck (**55G**) and pushing the bells **53D** (inset, below).

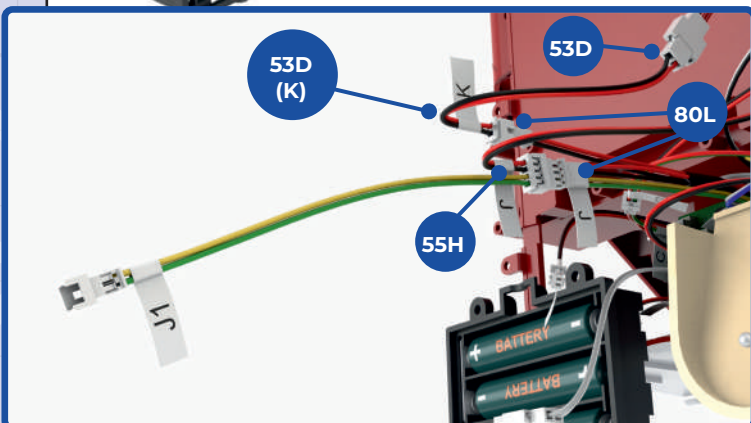

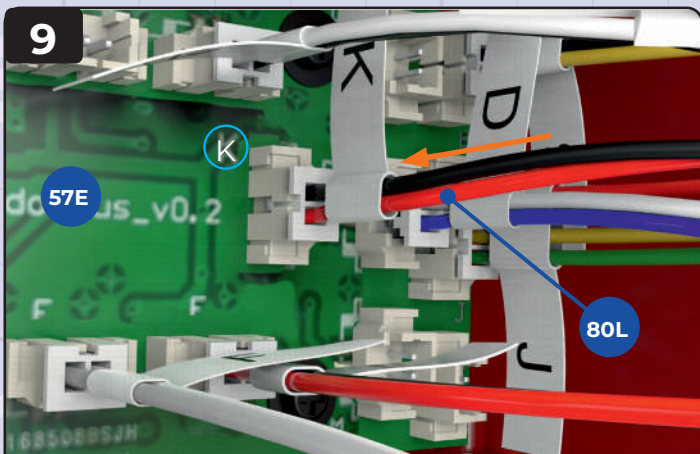

9 If you want a buzzer sound, plug the socket labelled **K** on the end of the black-red extender cable (**80L**) into the socket marked **K** on the circuit board **57E**. Pull the cord and press the buttons (as in step 8) to check that the buzzer sound is working.

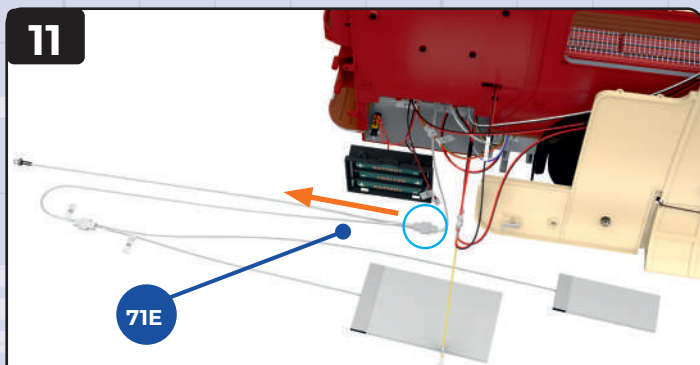

11 The grey-white extender cable **80K** needs to be fitted into cable **F** (**71E**). Begin by disconnecting the intermediate plug in the grey-white cable **F** (circled, above). Fit the grey-white extender cable **F** (**80K**) between the two connectors in cable **F** (**71E**, circled, below).

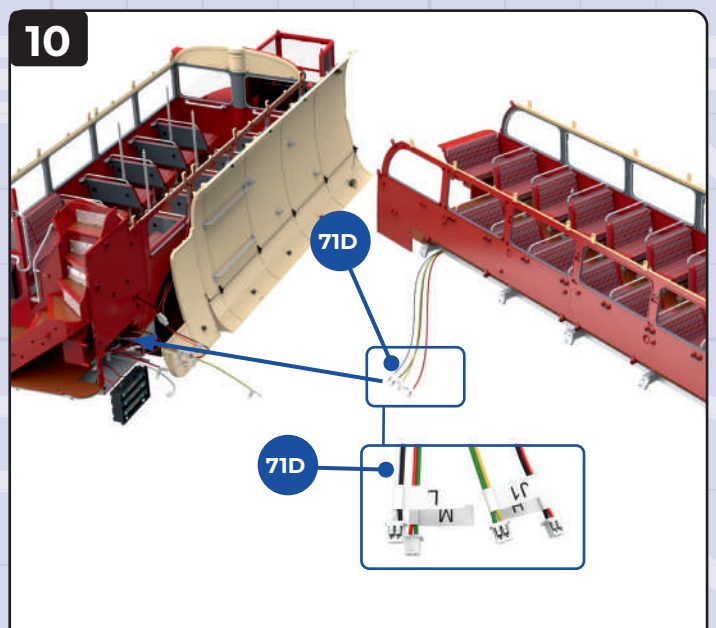
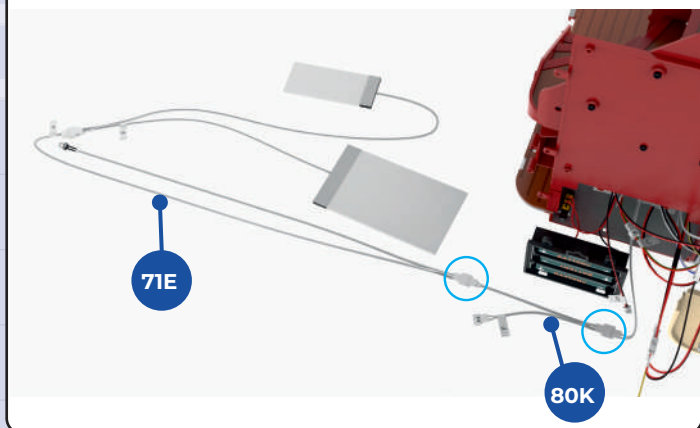

10 Take the black-white cable **L** (**71D**) and plug it into socket **L** in the circuit board **57E** (inset, right).

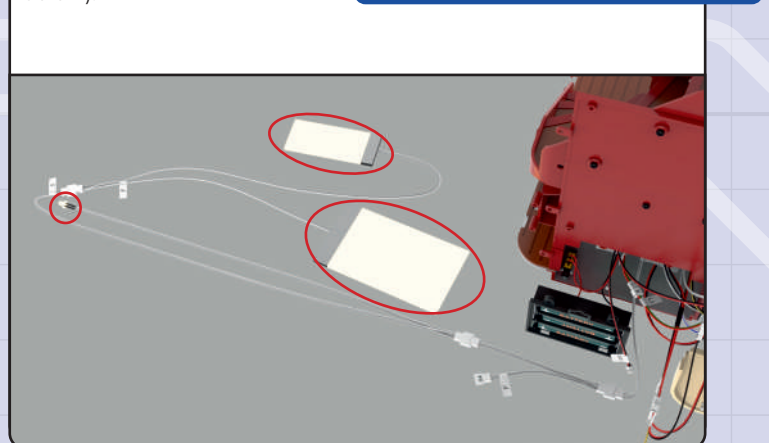
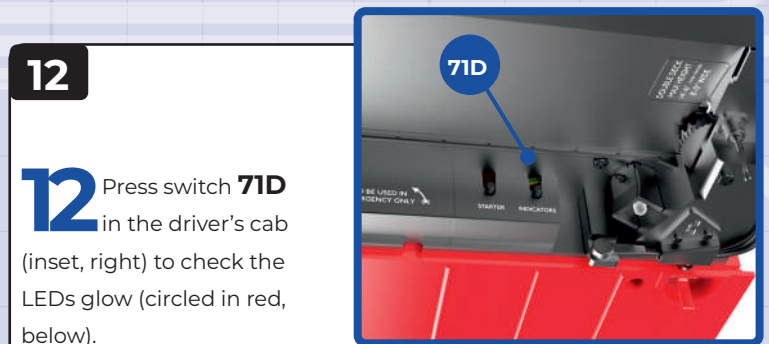

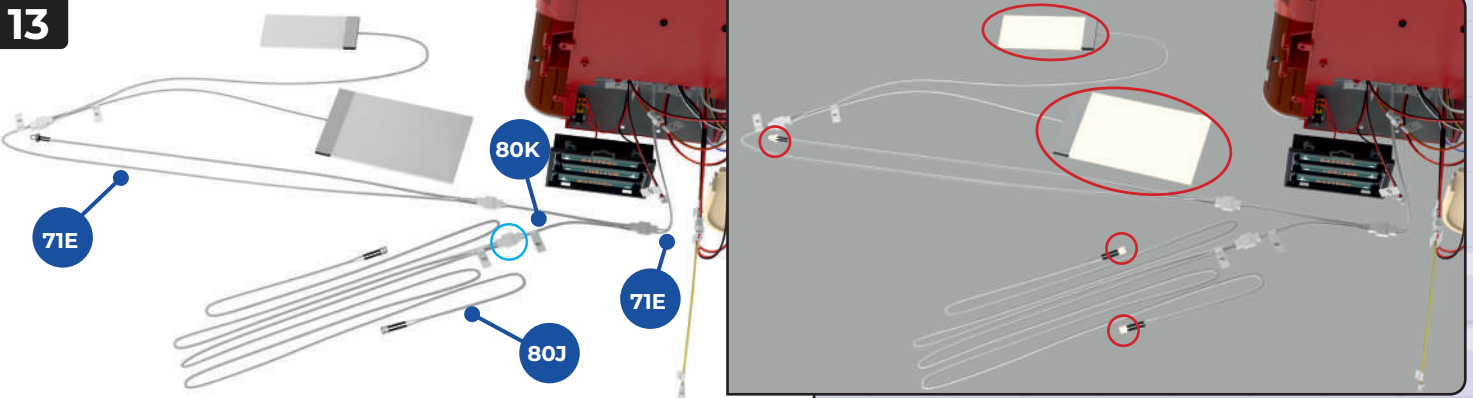

13 Connect grey-white cable **F (80J)** to the free socket of extender cable **F (80K)**, circled in blue. As in the previous step, press switch **71D** to check LEDs glow (circled in red, right).

Finished views



The front window assembly has been started, and cables have been extended.

