

STEVE MCQUEEN'S ICONIC **PORSCHE** **917KH**



Pack 06

BUILD INSTRUCTIONS

**STAGE 38: FITTING THE LEFT SIDE FRAME,
THE FUEL FILTER AND THE ENGINE**

**STAGE 39: FITTING THE RIGHT SIDE FRAME
AND JOINING THE FUEL LINE**

**STAGE 40: INSTALLING THE IGNITION COILS
AND THE BRAKE LINES**

**STAGE 41: ASSEMBLING THE LEFT
REAR SUSPENSION**

**STAGE 42: ASSEMBLING THE RIGHT
REAR SUSPENSION**

**STAGE 43: INSTALLING THE REAR AXLE
AND THE SUSPENSION**

**STAGE 44: BUILDING THE REAR BRAKE DISCS
AND FITTING THE CALIPERS**

**STAGE 45: ADDING THE REINFORCEMENT
FRAME AND BUILDING THE LEFT
TRANSMISSION LINE**

Porsche, the Porsche shield and the distinctive design of Porsche cars are trademarks and trade dress of Porsche AG. Permission granted.

The Gulf trademarks are used under license from Gulf Oil International Ltd.

Personality rights of Steve McQueen are used with permission of Chadwick McQueen and The Terry McQueen Testamentary Trust.

Represented exclusively by Greenlight.

AGORA
MODELS

Advice from the experts

Spare screws are included with each part. Occasionally, you may be instructed to keep spare or unused screws for a later stage. Keep these spares in a safe place and label them correctly.

Please make sure you don't mix up the screws. They look quite similar, but the threads do vary slightly. Using the wrong screws may damage the parts.

When securing parts together using multiple screws, fit each screw loosely to ensure all the parts are correctly aligned before gently tightening them firmly, but not overtight, in the order in which you placed them.

The screwdriver can be magnetized by stroking it with a magnet (fridge magnet, etc.) enabling it to hold the screws and make assembly easier.

If a screw is tight going into a metal part, do not force it as you may shear the head off. Remove it and put a tiny smear of Vaseline, soap or light oil on the thread. That will lubricate it and make it easier to drive home.

During the course of this build, you will receive many pieces that you will assemble immediately – following the instructions in the corresponding stage – and other pieces that you should store safely to one side, for use in future assembly stages.

Left and Right! When building your Porsche 917KH, the left or right hand side refers to each side as you are sitting in the car.



WARNING: Some parts are assembled using magnets. These magnets can cause serious injury if they are swallowed. Keep away from children. If you suspect a magnet has been swallowed, seek medical help straight away.

STAGE 38: FITTING THE LEFT SIDE FRAME, THE FUEL FILTER AND THE ENGINE

38A Left side frame

38B Fuel filter

38C Fuel line

38D Connector (x3)

BM Screw 2.0 x 4 mm (x4)

JM Screw 2.0 x 5 mm (x2)

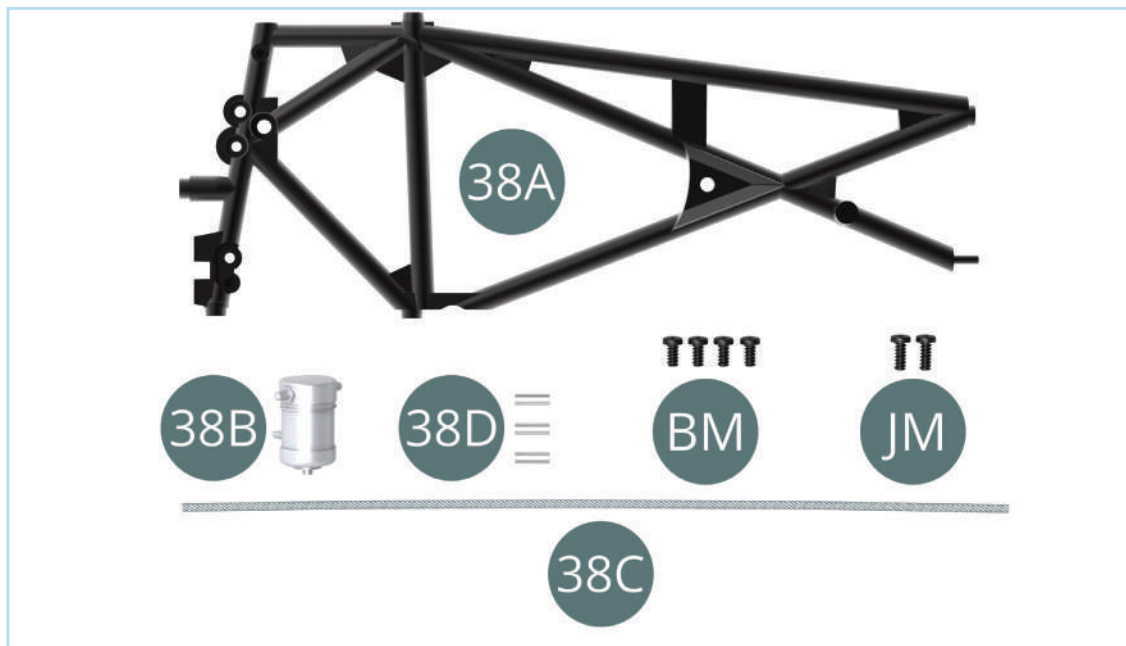

ASSEMBLY DIAGRAM

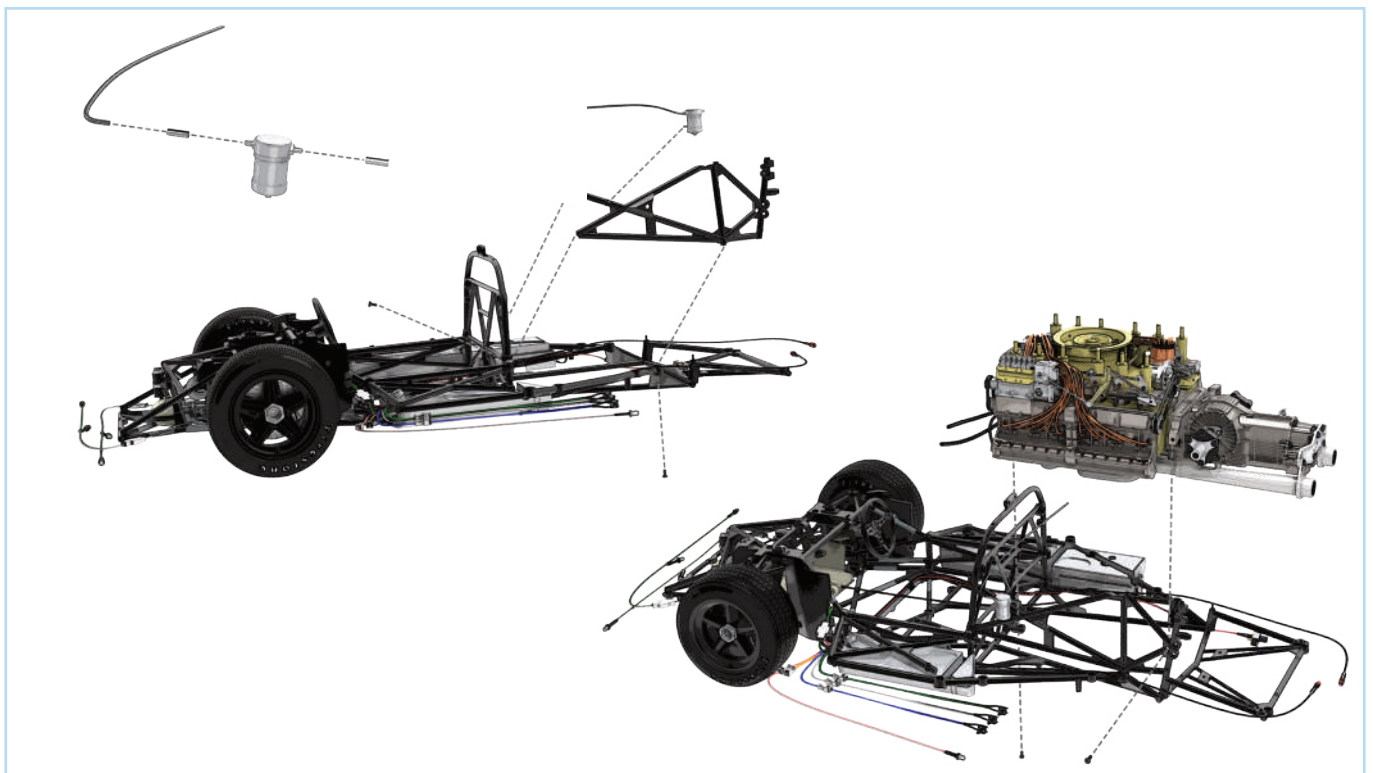

STAGE 38: FITTING THE LEFT SIDE FRAME, THE FUEL FILTER AND THE ENGINE

STEP 1

Attach two of the **connectors (38D)** on the pins of the **fuel filter (38B)** by pushing them firmly in place. Fit a **fuel line (38C)** onto one of the connectors as shown. Once in place, bend the fuel line as shown by the blue arrow.

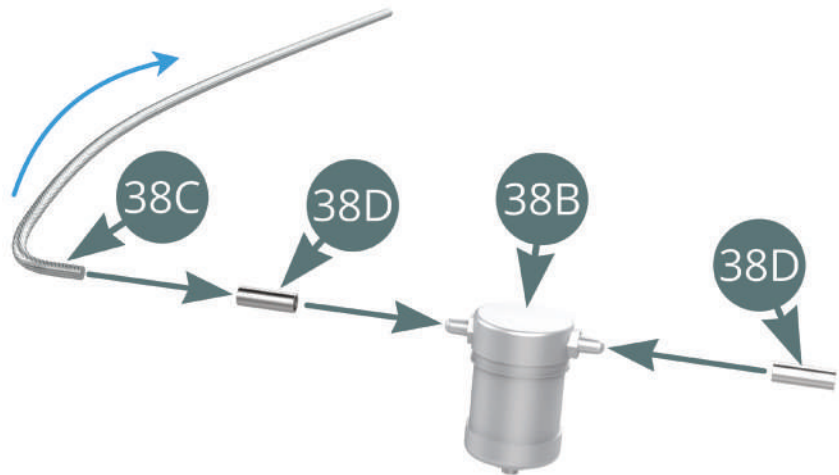

Position the **fuel filter (38B)** onto the **left side frame (38A)** using the D-shaped pin and hole.

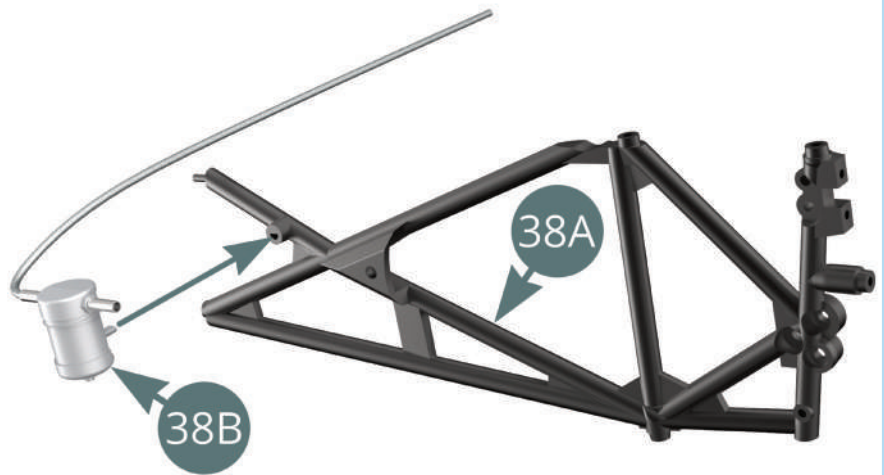

Fit the **left side frame (38A)** into the **cockpit partition frame (37A)** and the **chassis (25A)** as indicated by the blue arrows. Note that the fuel line runs over the top of the frame (circled).

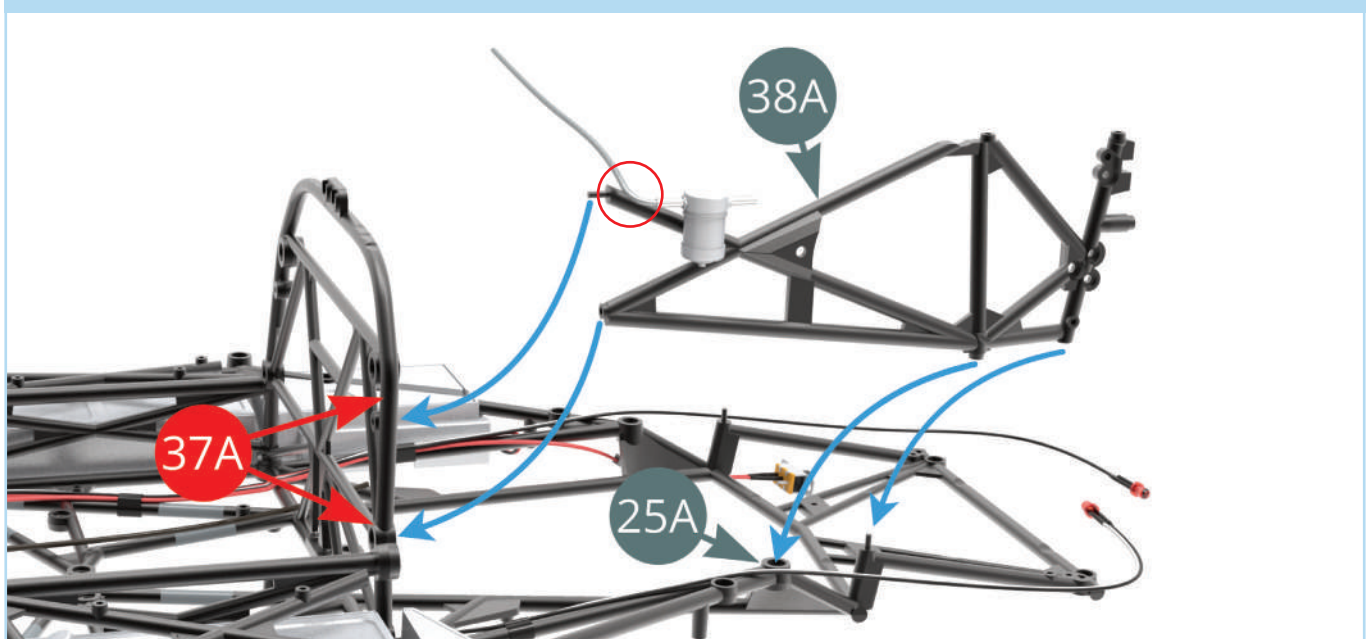

STAGE 38: FITTING THE LEFT SIDE FRAME, THE FUEL FILTER AND THE ENGINE

Carefully turn the assembly over while holding the frame in position and secure them together using a **BM** screw.

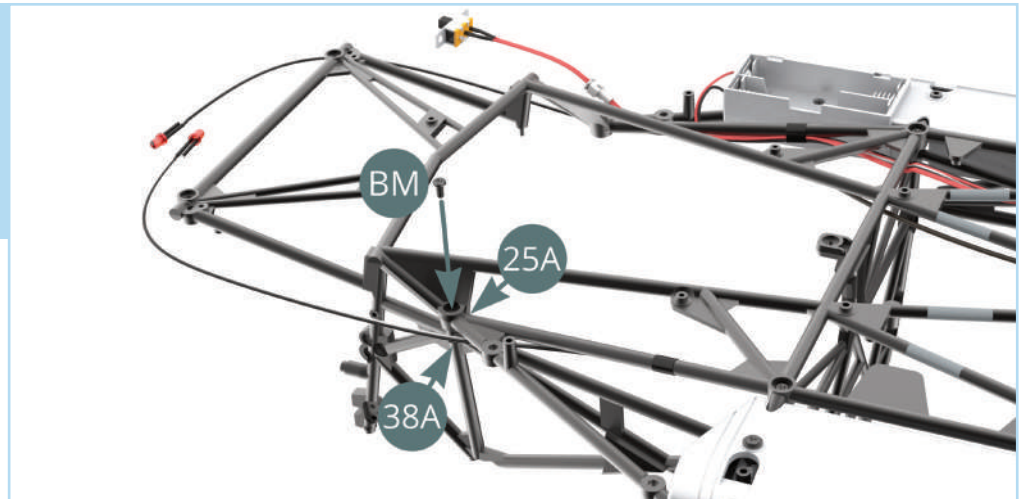

Then turn the assembly back over and secure the frame to the partition with a **BM** screw.

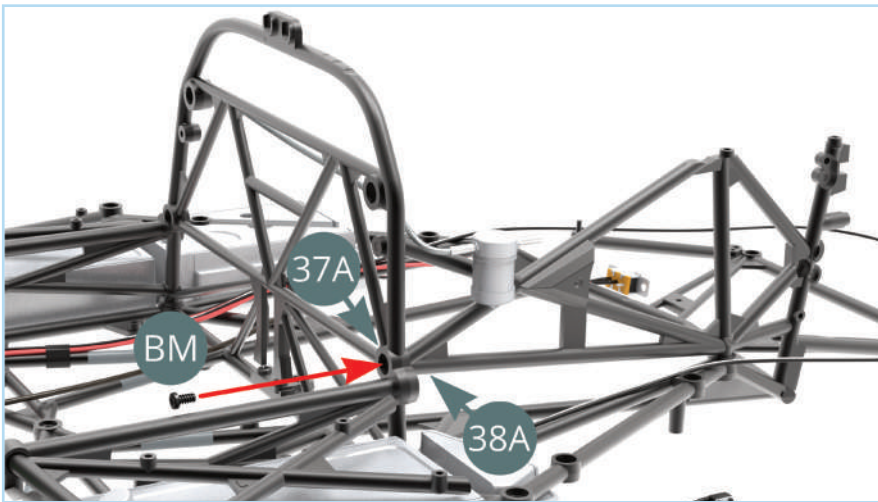

STEP 2

Retrieve the engine assembly (Stage 37) and align it with the chassis as shown. Fit the engine in place using the connection points highlighted by the red arrows in the images below.

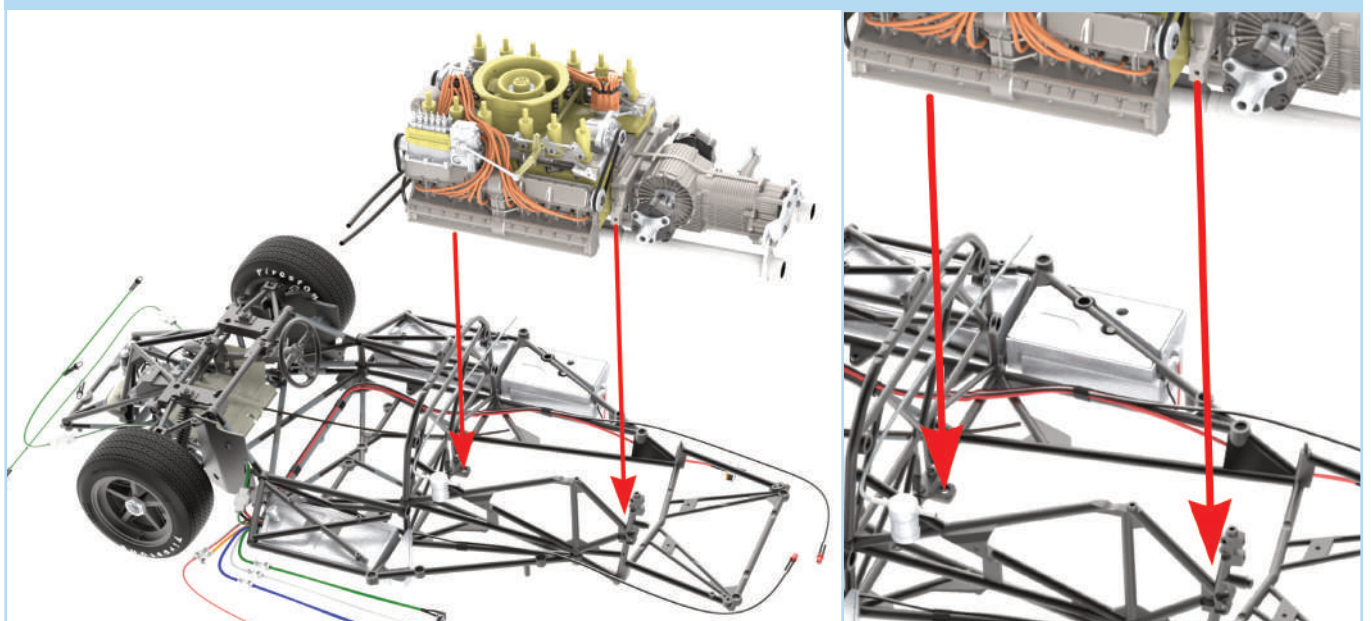

STAGE 38: FITTING THE LEFT SIDE FRAME, THE FUEL FILTER AND THE ENGINE

STEP 3

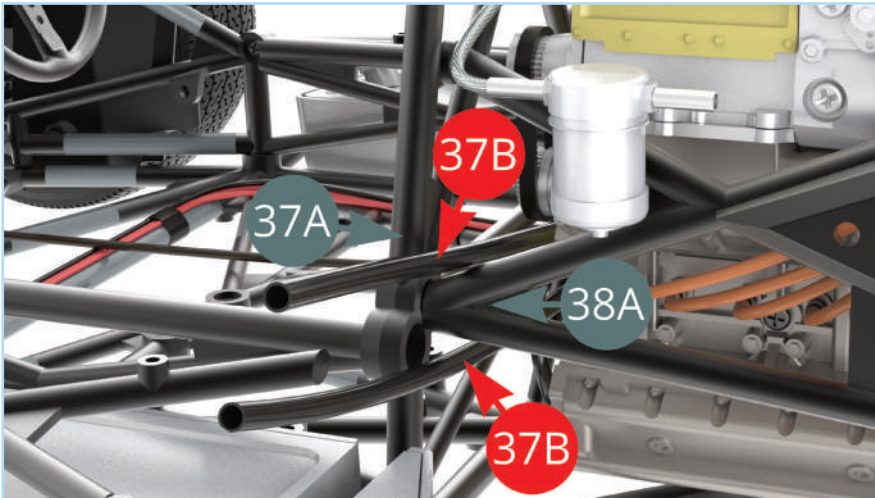

Feed the two **oil hoses (37B)** through the left side frame.

Carefully turn the assembly over and secure the engine using a **BM** screw driven through the **front engine mount (25A)** into the **water pump housing (8A)**.

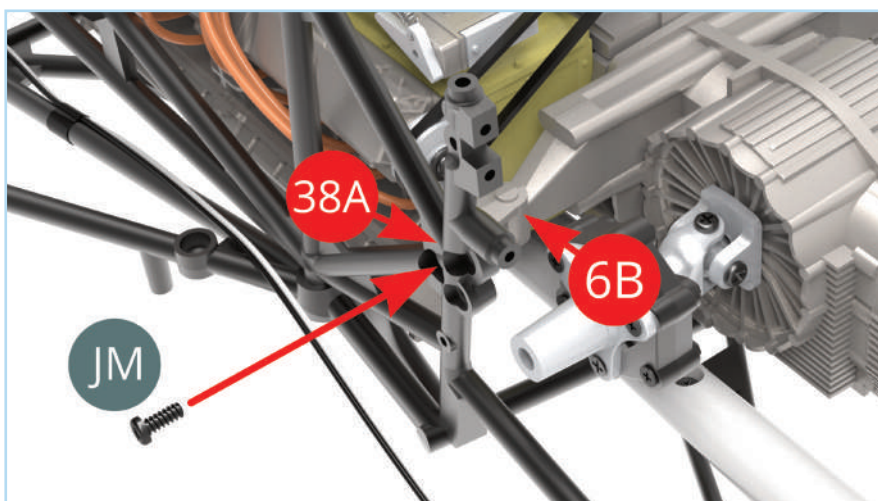
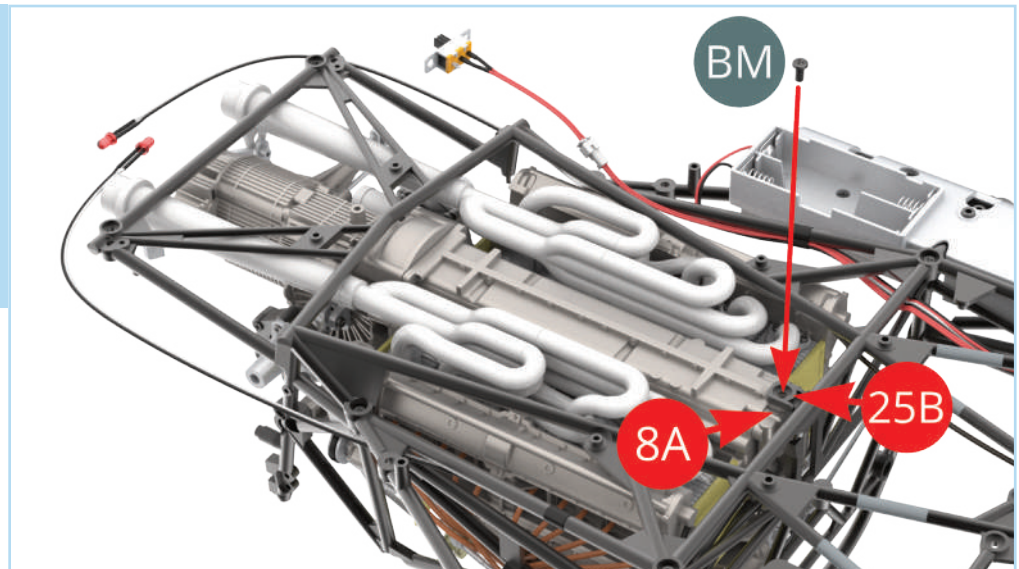

Fix the engine to the **left side frame (38A)** using a **JM** screw driven into the **left mounting bracket (6B)**.

STAGE 38: FITTING THE LEFT SIDE FRAME, THE FUEL FILTER AND THE ENGINE

STAGE COMPLETE

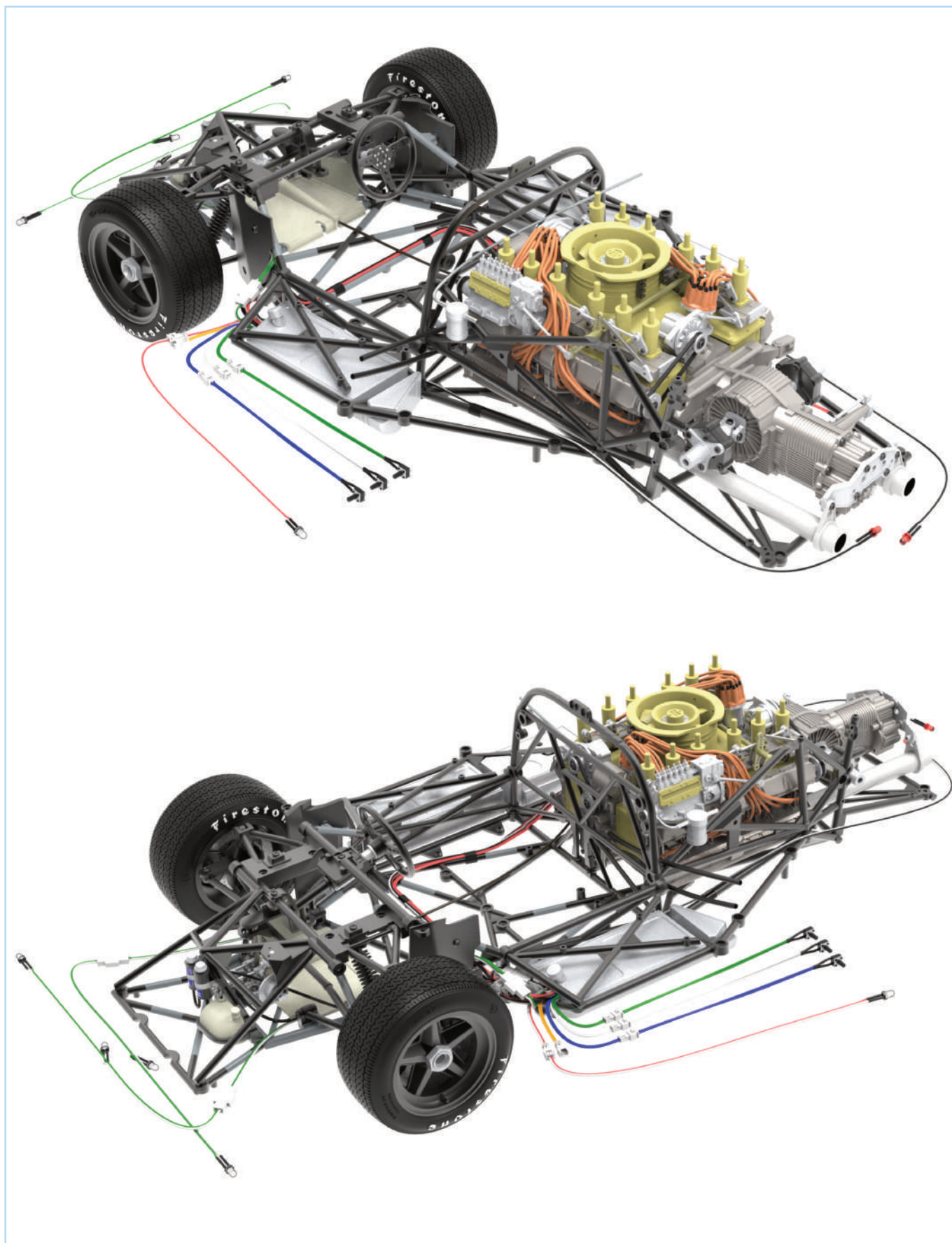

STAGE 39: FITTING THE RIGHT SIDE FRAME AND JOINING THE FUEL LINE

39A Right side frame

BM Screw 2.0 x 4 mm (x3)

39B Y branch

39C Connector (x4)

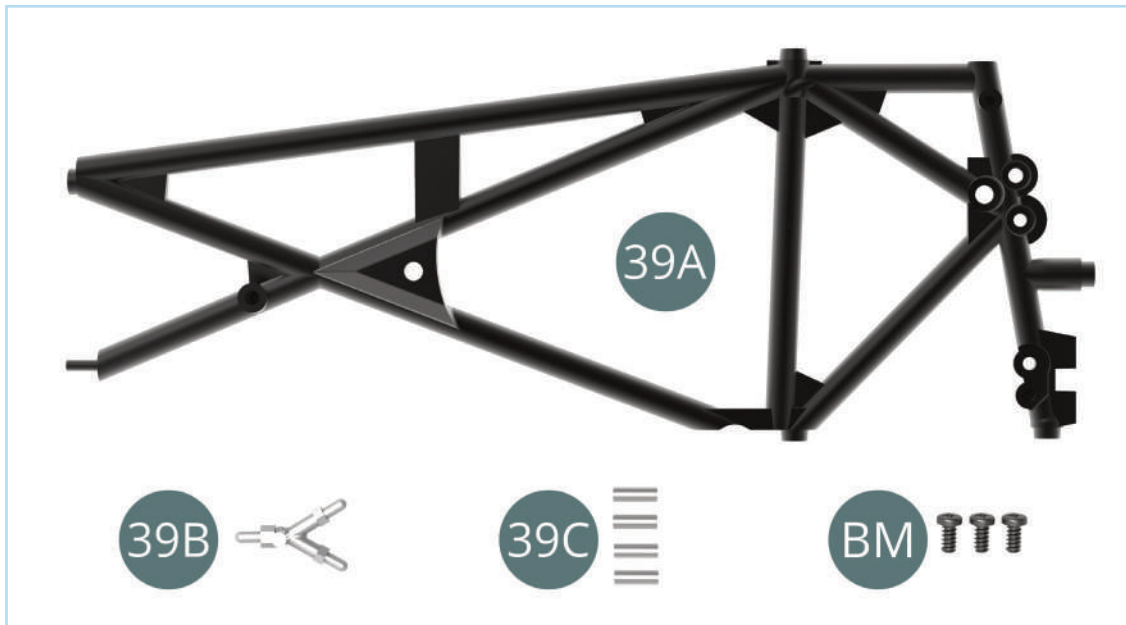

ASSEMBLY DIAGRAM

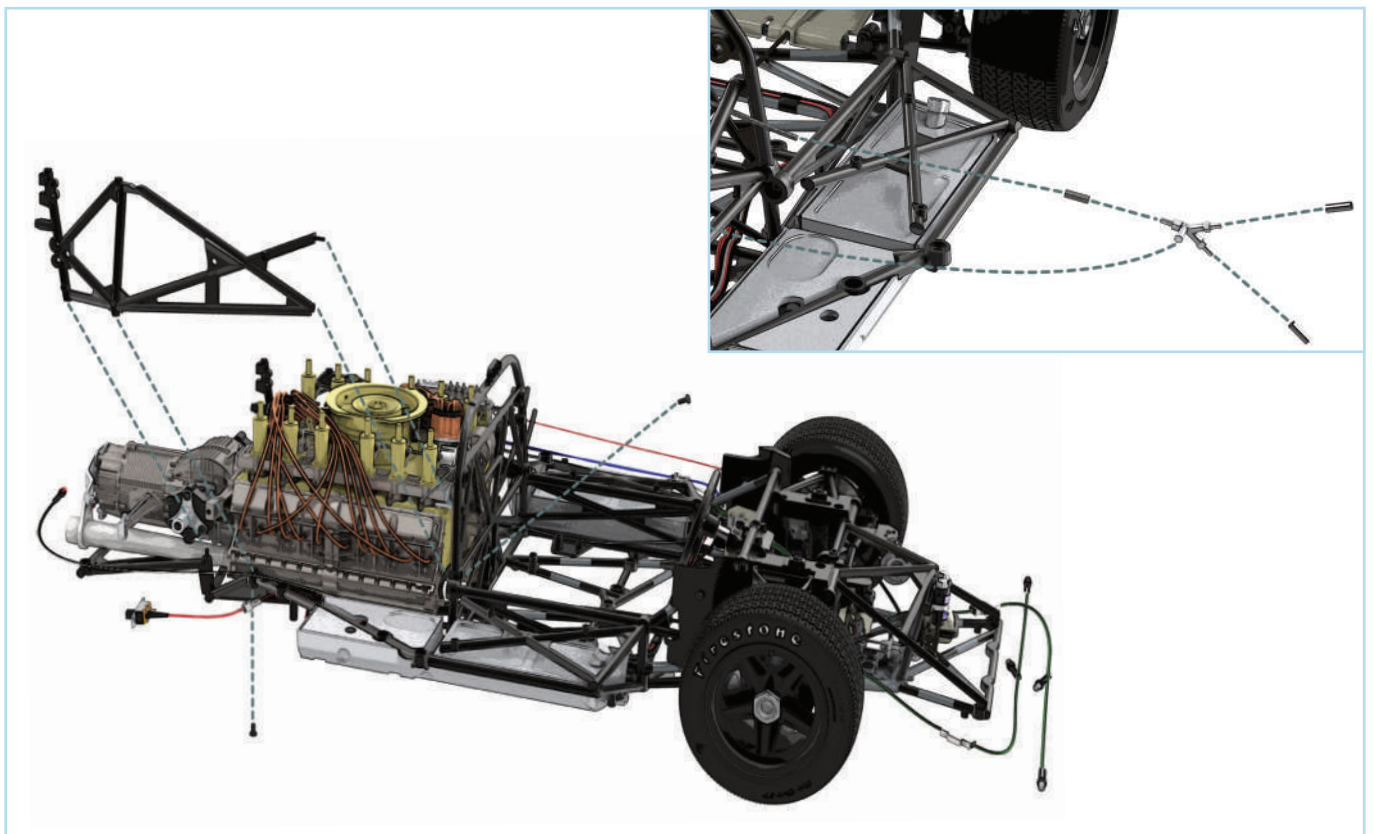

STAGE 39: FITTING THE RIGHT SIDE FRAME AND JOINING THE FUEL LINE

STEP 1

Fit the **right side frame (39A)** onto the **chassis (25A)** and **cockpit partition frame (37A)**. We recommend fitting the frame to the cockpit partition first then guiding the other connections onto the chassis. You may need to apply some pressure towards the partition until the frame fits in place.

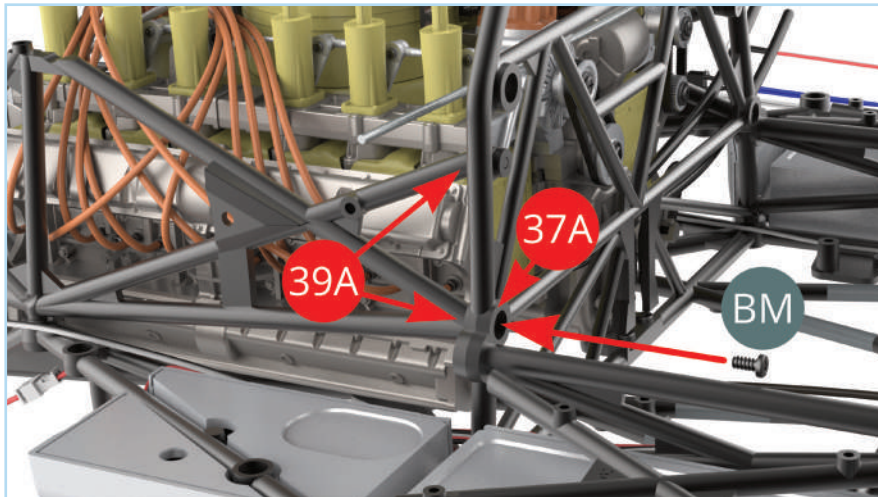
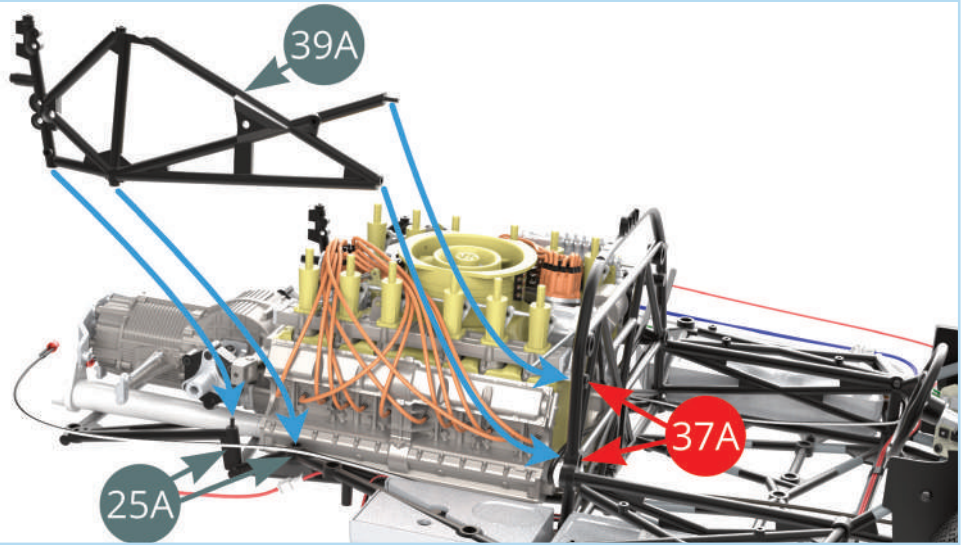

Fix the frame to the central partition using a **BM** screw.

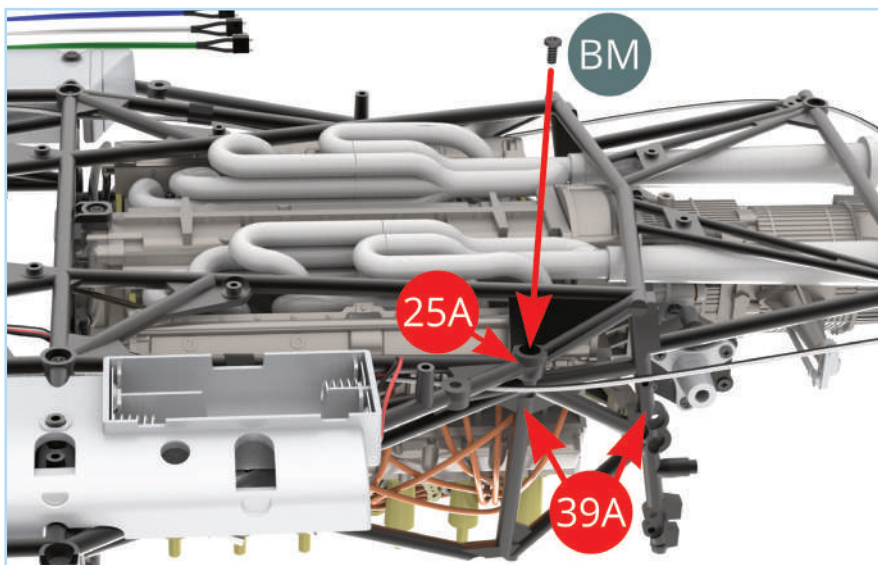

Then carefully turn the assembly over and fix the frame to the chassis using another **BM** screw as shown.

STAGE 39: FITTING THE RIGHT SIDE FRAME AND JOINING THE FUEL LINE

STEP 2

Take the **Y branch (39B)** and attach the three **connectors (39C)** to the ends.

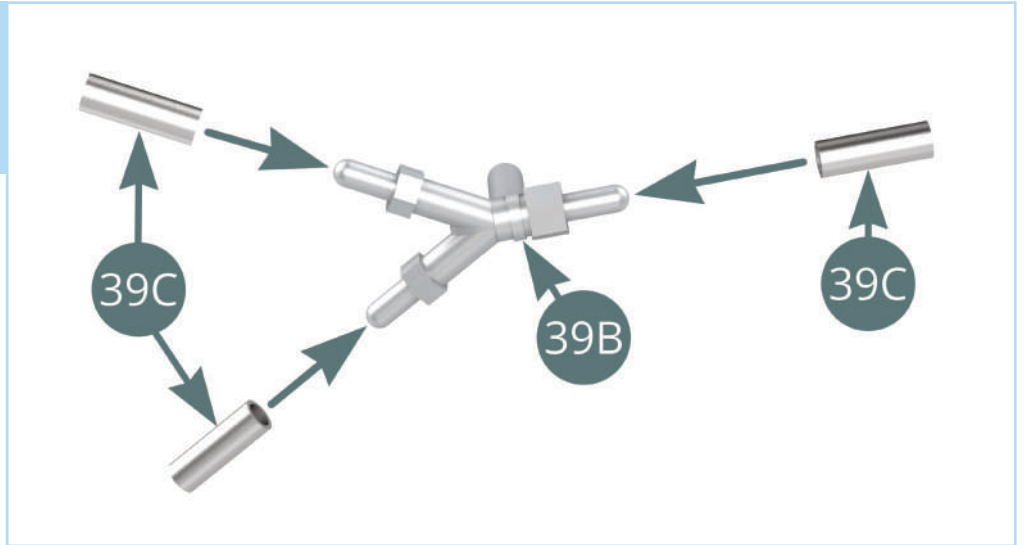

Pass the **fuel line (38C)** through the frame at the point indicated by the green arrow, then insert it into the **connector (39C)** at the end of the Y branch as shown.

Fit the pin of the Y branch into the hole located on the **right side frame (39A)** (blue arrow).

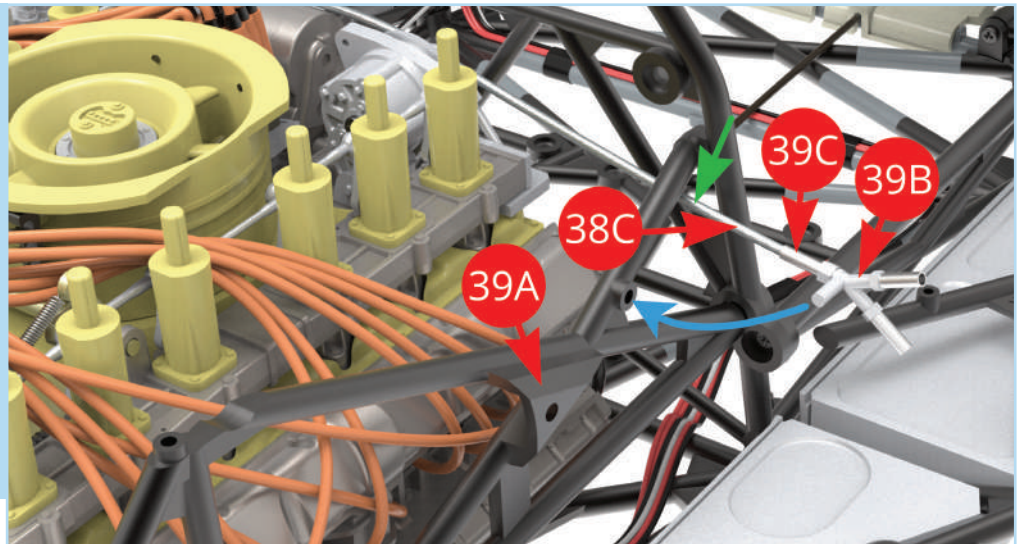

The Y branch and fuel line should look like this once connected to the frame.

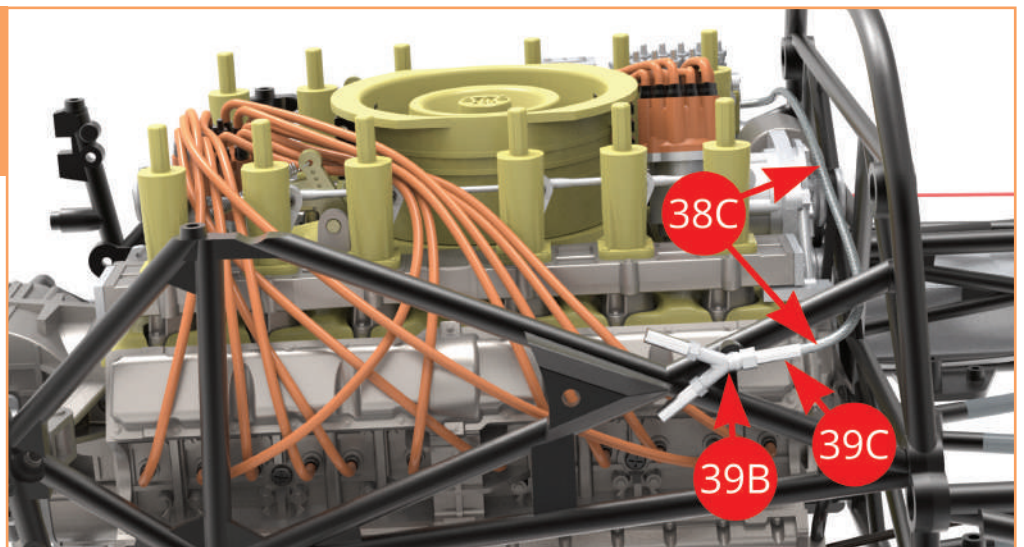

STAGE 39: FITTING THE RIGHT SIDE FRAME AND JOINING THE FUEL LINE

STAGE COMPLETE

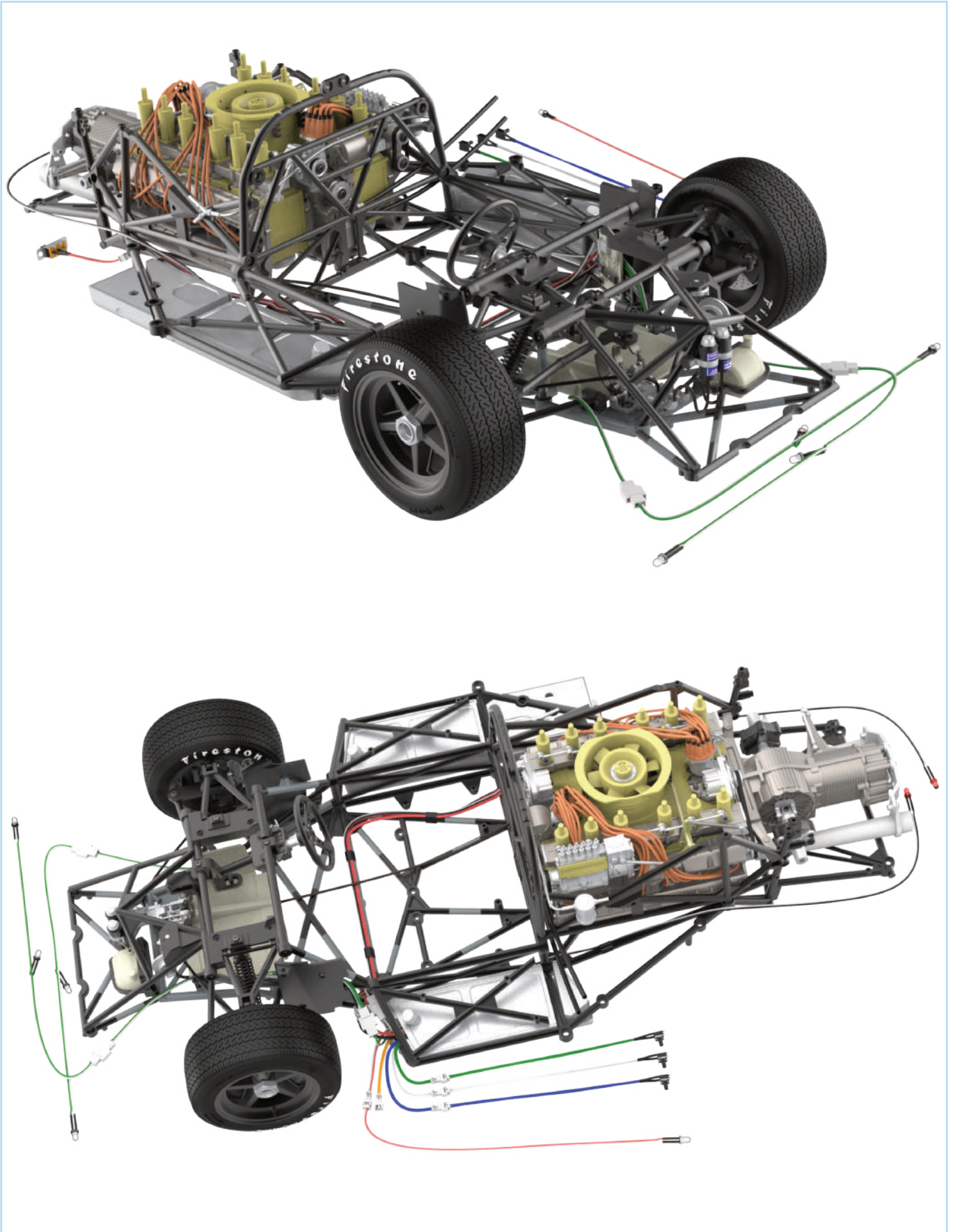

STAGE 40: INSTALLING THE IGNITION COILS AND THE BRAKE LINES

40A X frame

40B Ignition coil (x2)

40C High voltage cable (x2)

40D Connector (x2)

40E Brake line (x2)

40F Brake line (x2)

IM Screw 1.7 x 5 mm (x3)

JM Screw 2.0 x 5 mm (x2)

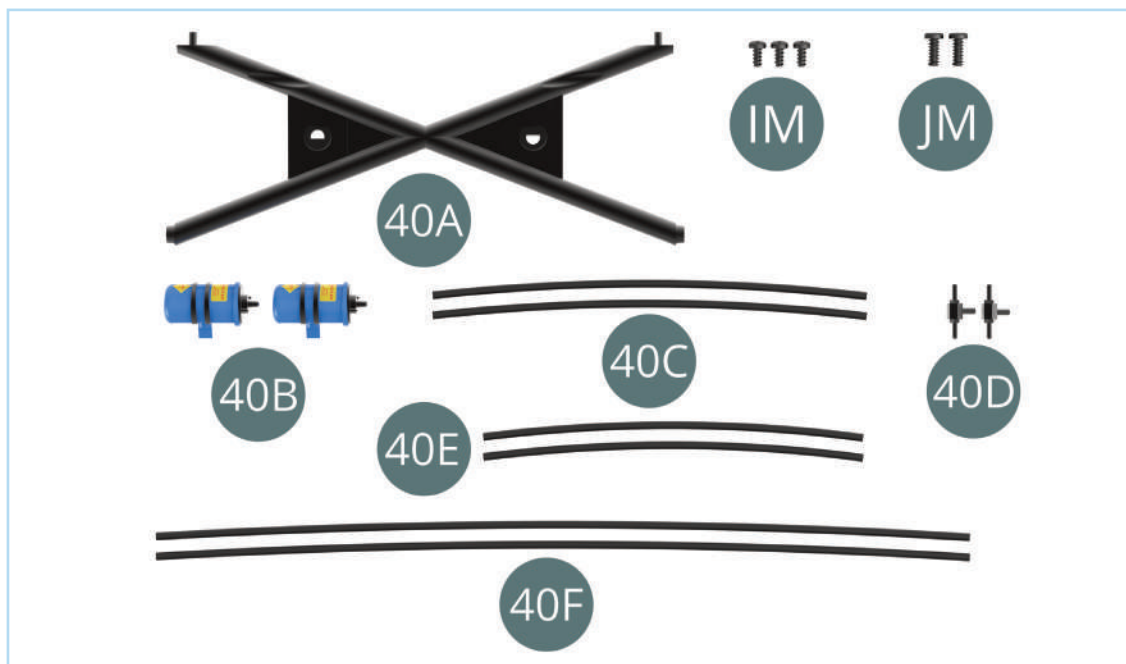

ASSEMBLY DIAGRAM

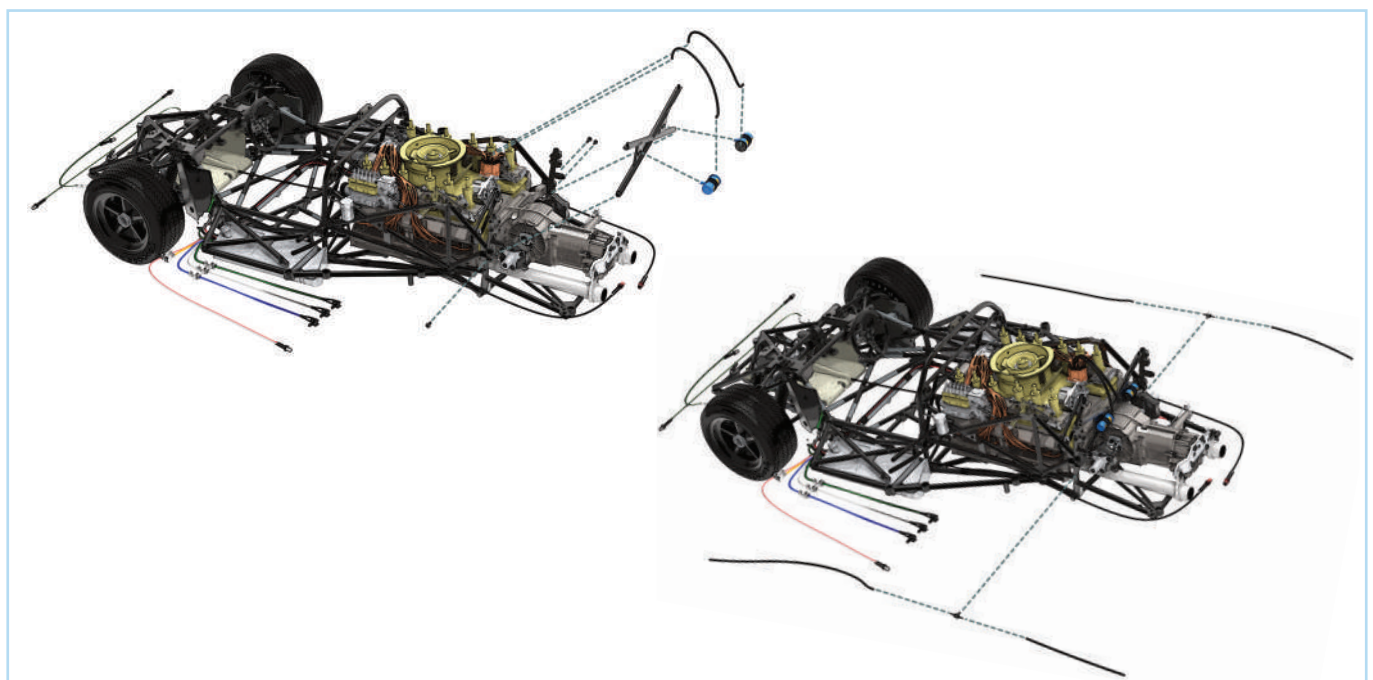

STAGE 40: INSTALLING THE IGNITION COILS AND THE BRAKE LINES

STEP 1

Make sure the X frame is oriented in the correct way as indicated by the green arrows before continuing. Fit the **high voltage cables (40C)** onto the pins at the top of the **ignition coils (40B)**, then press the coils into the **X frame (40A)** using the D-shaped fittings.

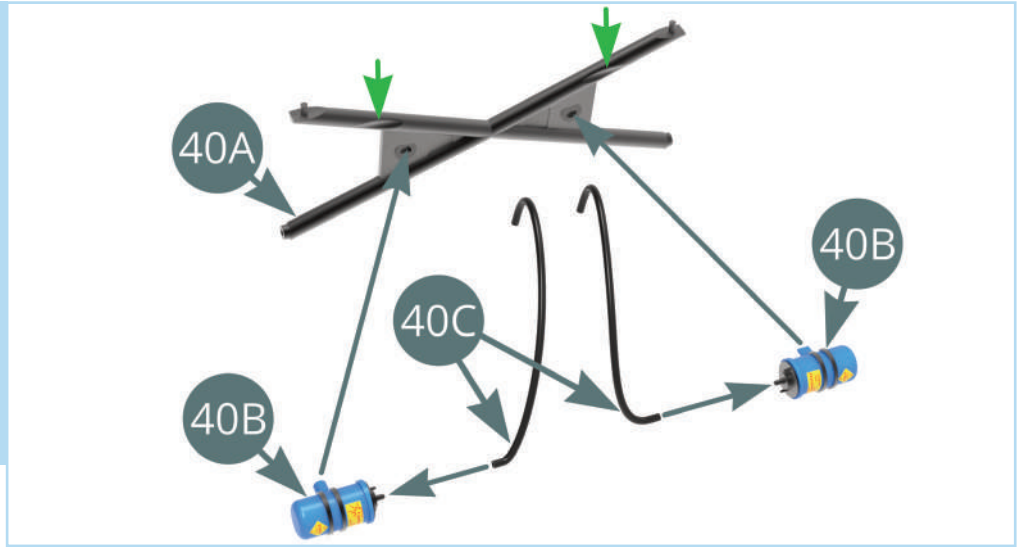

Align the X frame with the chassis assembly as shown. Position the ends of the X frame into the two side frames (**38A** and **39A**) (red arrows).

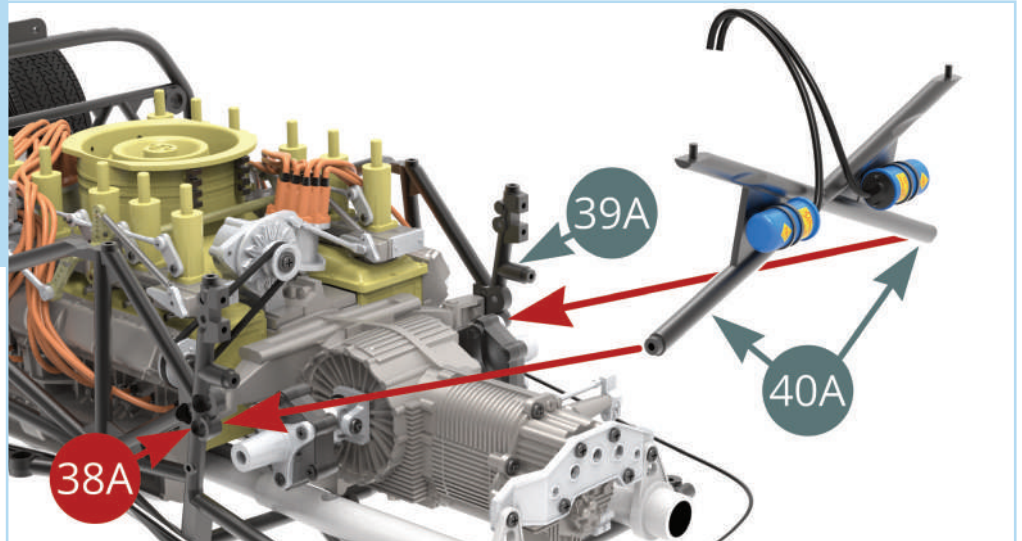

Secure the X frame (**40A**) to the **left side frame (38A)** using an **IM screw**.

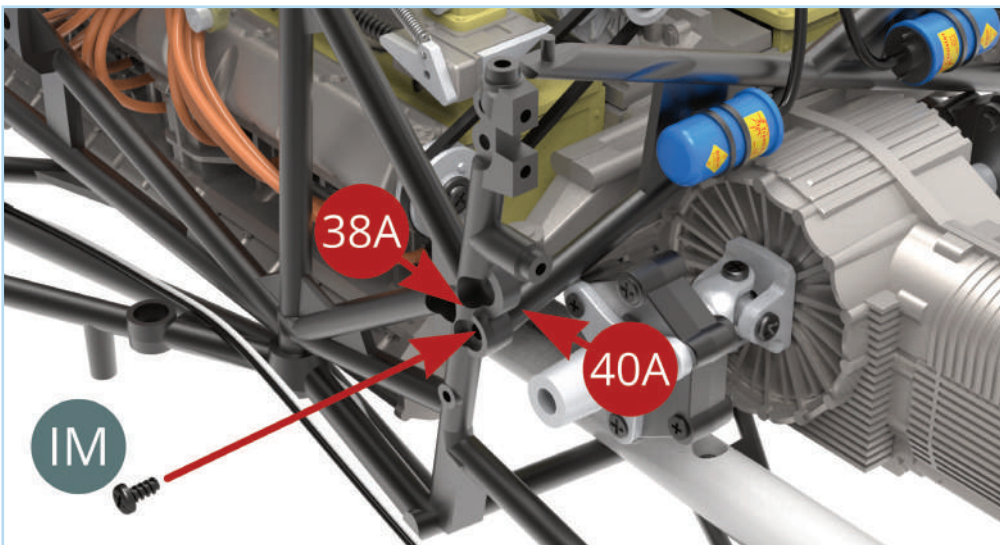

STAGE 40: INSTALLING THE IGNITION COILS AND THE BRAKE LINES

Secure the **X frame (40A)** to the **right side frame (39A)** using an **IM screw**. Then drive a **JM screw** into the **right engine mount (4B)** as shown.

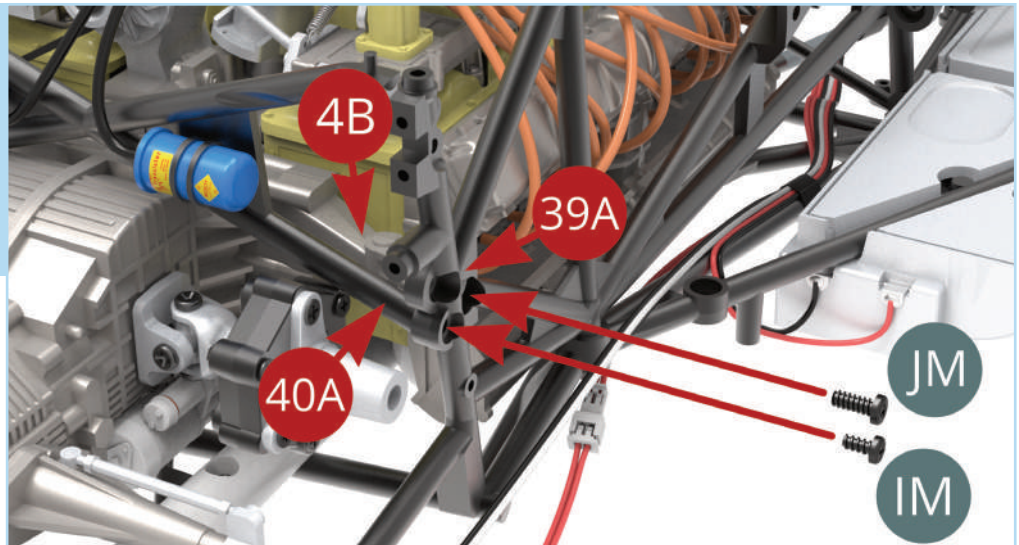

Fit the ends of the **high voltage cables (40C)** into the two available **ignition wire connectors (23C)**.

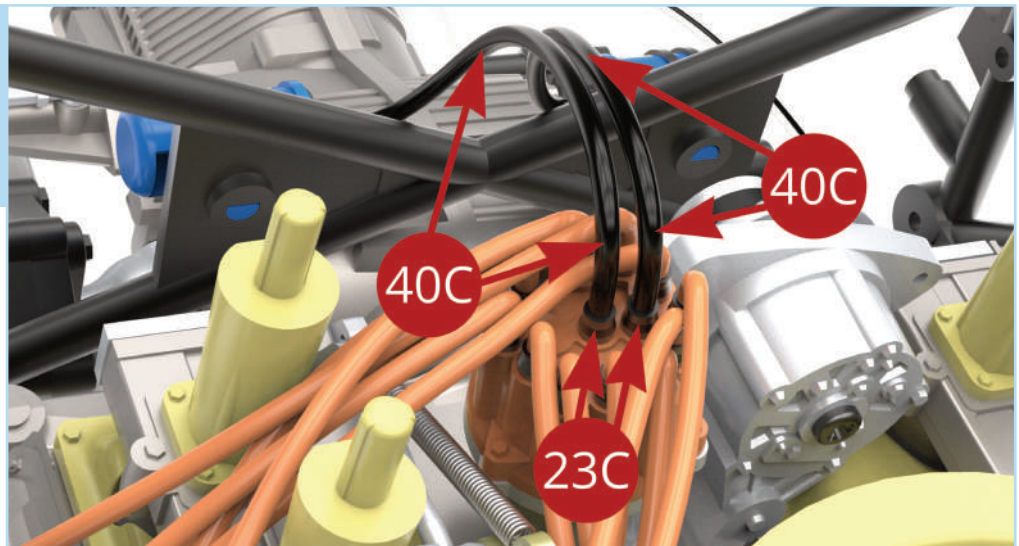

STEP 2

Attach one of the shorter **brake lines (40E)** and longer **brake lines (40F)** to a **connector (40D)**.

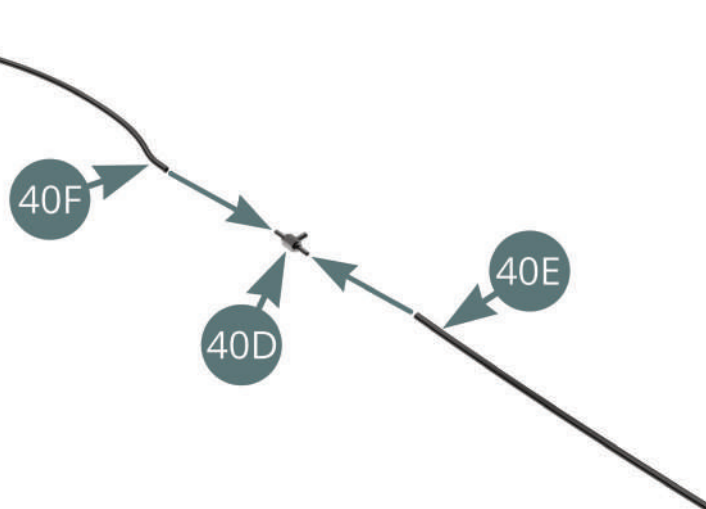

STAGE 40: INSTALLING THE IGNITION COILS AND THE BRAKE LINES

Fit the **connector (40D)** into the **left side frame (38A)** as shown. Note that the shorter **brake line (40E)** leads to the rear of the assembly while the longer **brake line (40F)** leads towards the front.

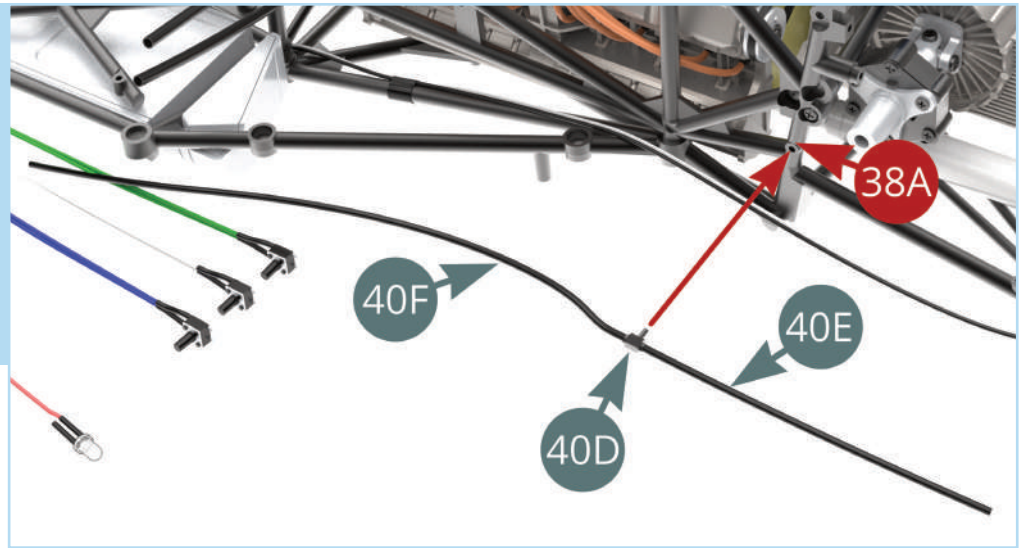

Guide the **longer brake line (40F)** through the frames as shown in the image.

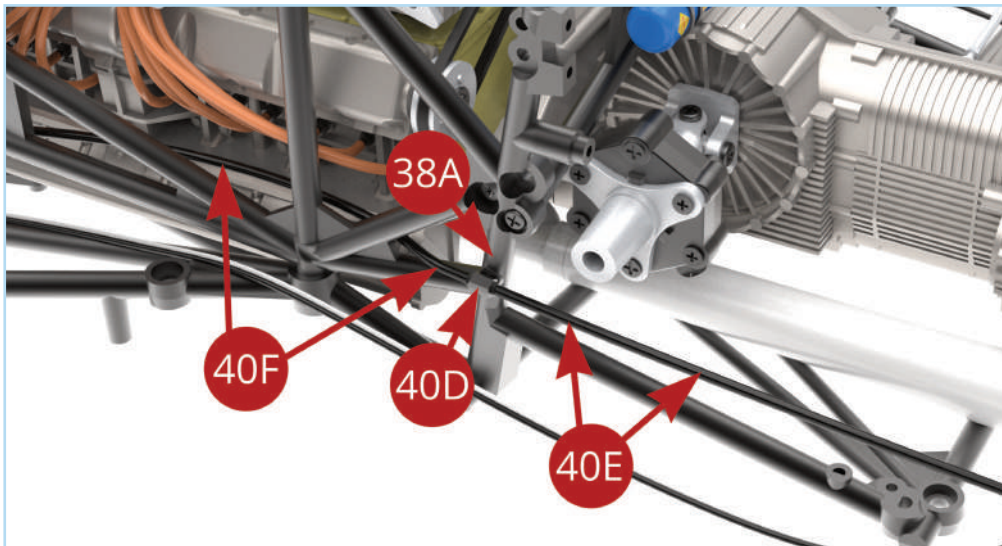

STEP 3

Attach the remaining short **brake line (40E)** and long **brake line (40F)** to remaining **connector (40D)**.

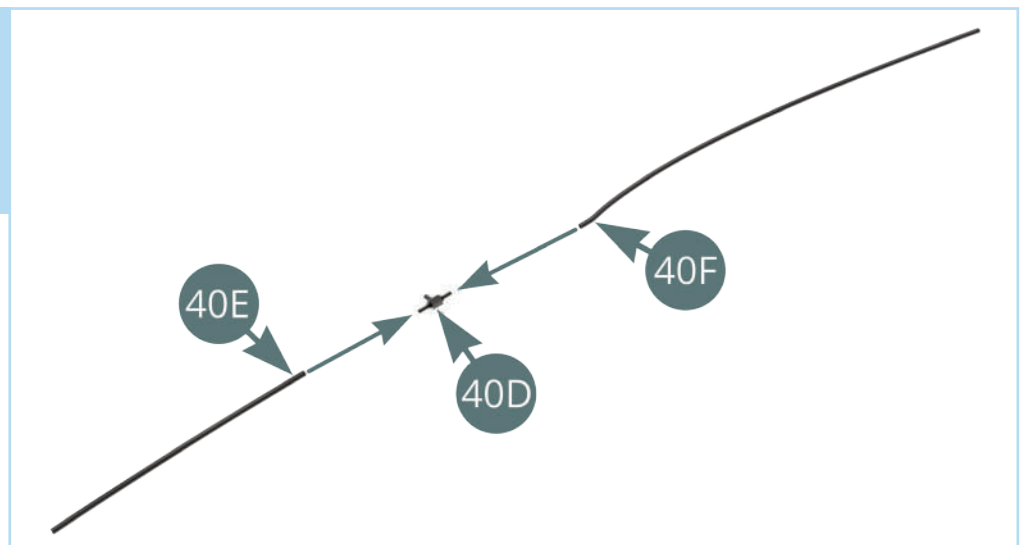

STAGE 40: INSTALLING THE IGNITION COILS AND THE BRAKE LINES

Fit the **connector (40D)** to the **right side frame (39A)** in the same manner as before and guide the longer brake line through the frame.

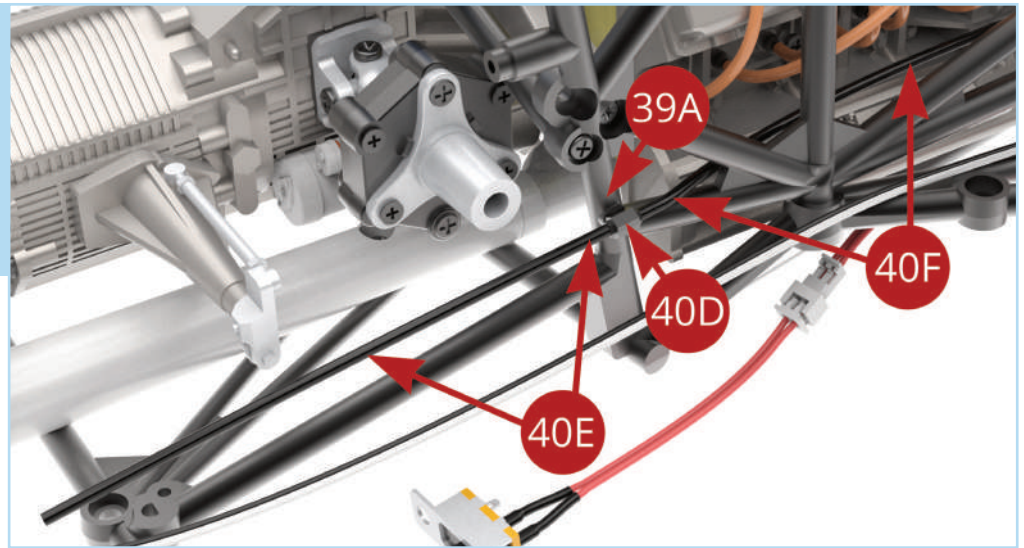

STAGE COMPLETE

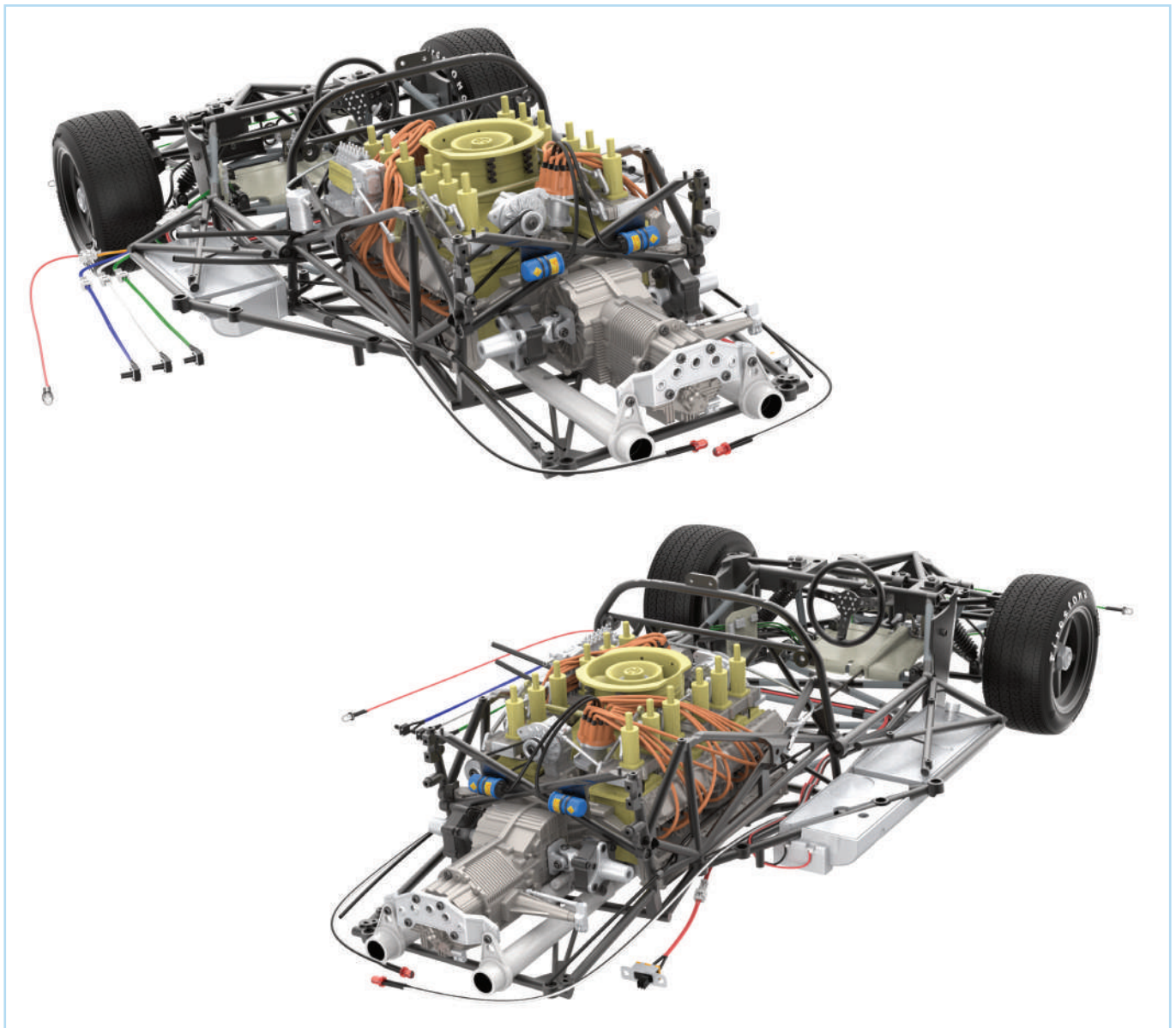

STAGE 41: ASSEMBLING THE LEFT REAR SUSPENSION

41A Rear left upright

41B Radius arm with upper link

41C Bottom wishbone

41D Radius arm

41E Bracket

41F Shock absorber piston

41G Bracket

41H Shock absorber cylinder

41I Shock absorber spring

BM Screw 2.0 x 4 mm (x2)

CM Screw 2.0 x 3 x 5 mm (x2)

DM Screw 2.0 x 8 mm (x3)

KM Screw 1.7 x 3 x 5 mm (x2)

NM Screw 2.0 x 7 mm (x2)

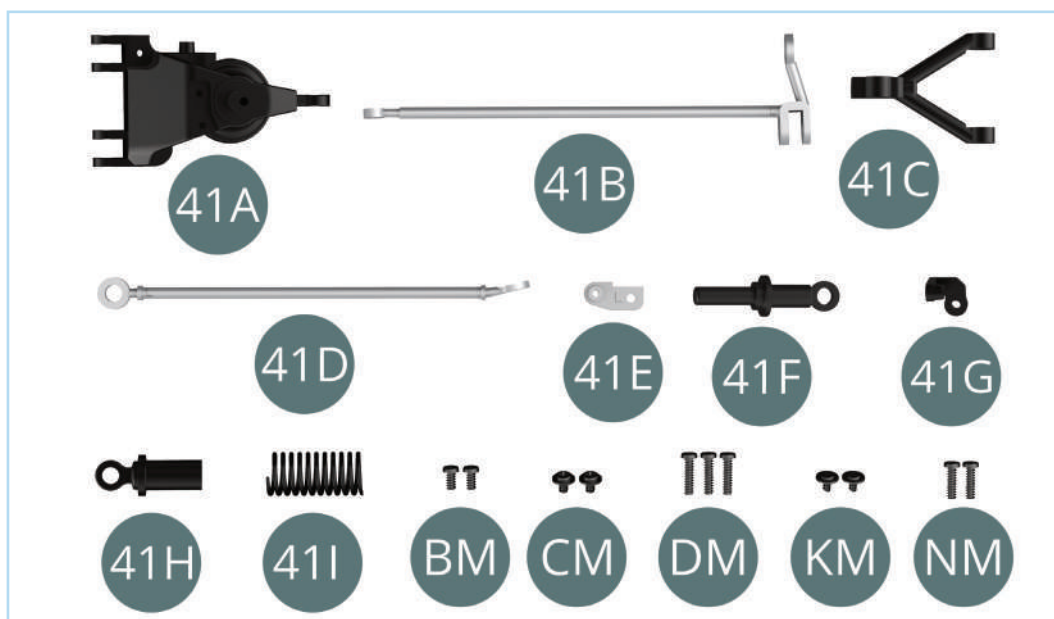

ASSEMBLY DIAGRAM

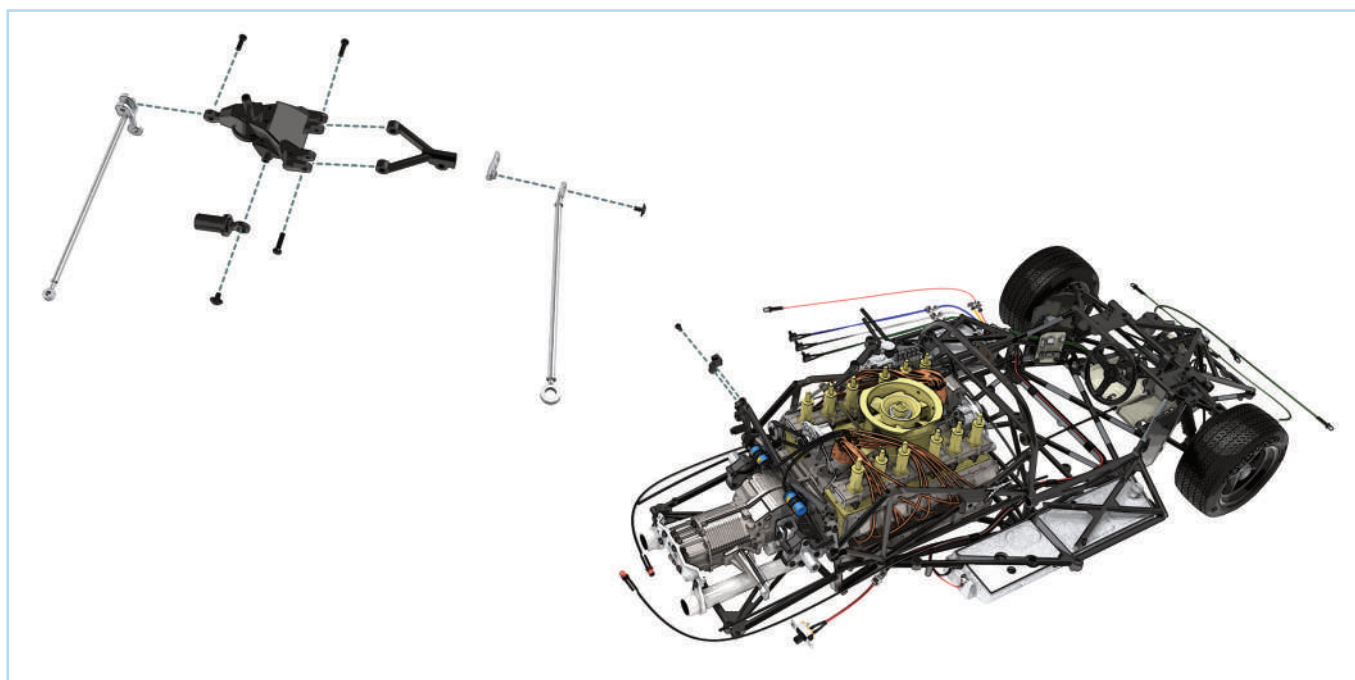

STAGE 41: ASSEMBLING THE LEFT REAR SUSPENSION

STEP 1

Take the **bottom wishbone (41C)** and align it with the **rear left upright (41A)** as shown. Fit it in place then secure by driving two **DM** screws through the sides of the upright.

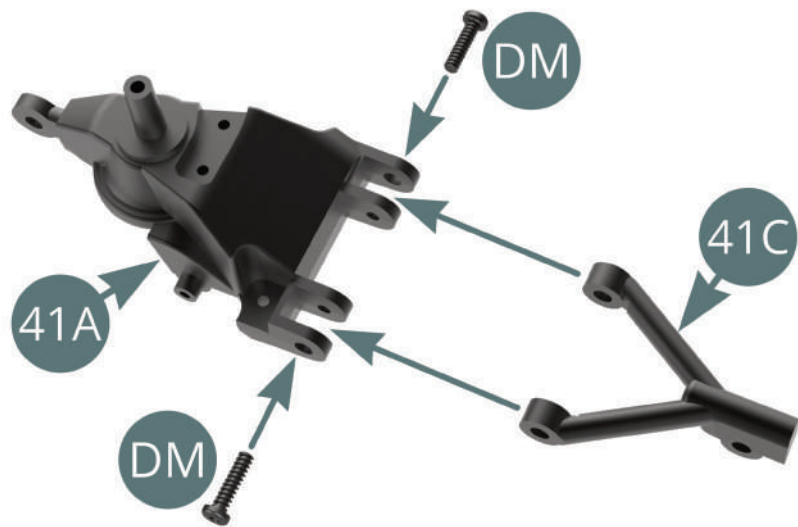

Place the **shock absorber cylinder (41H)** on the side of the **rear left upright (41A)** and fix it using a **CM** screw. Don't overtighten the screw, the cylinder should be able to move freely.

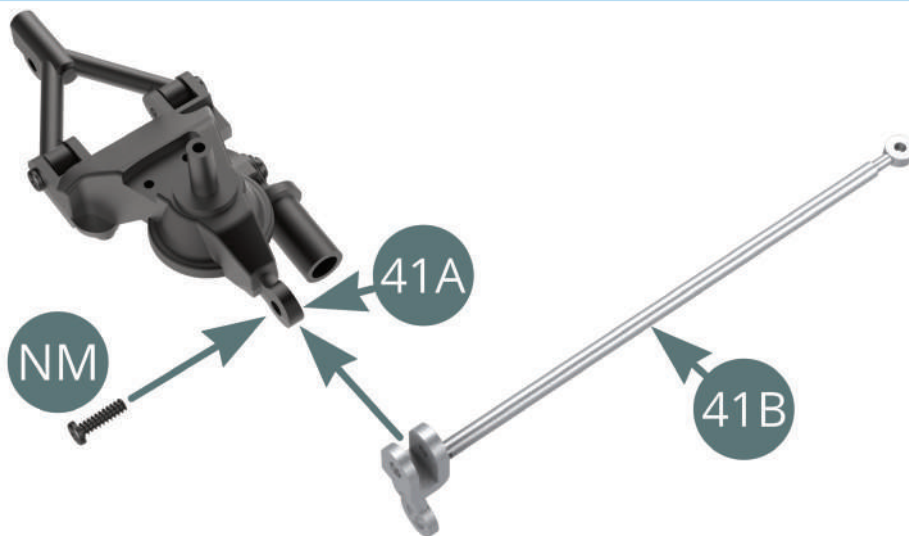
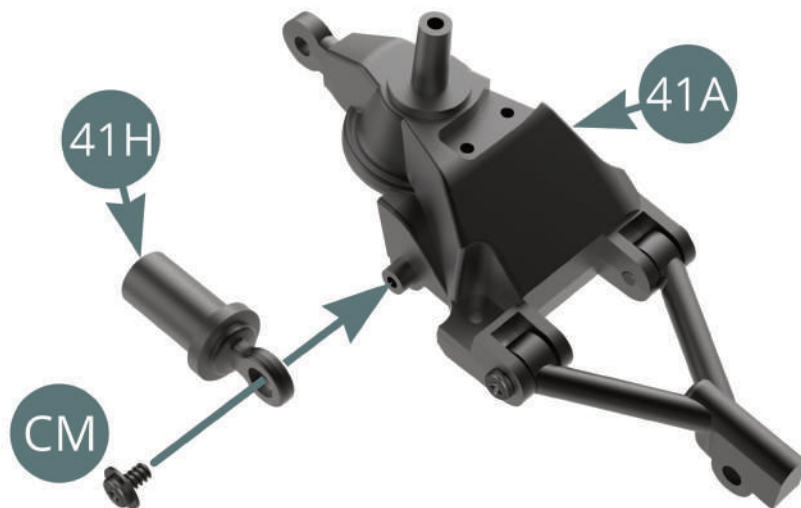

Push the joint of the **radius arm with upper link (41B)** onto the **left rear upright (41A)** as shown and secure in place using an **NM** screw.

STAGE 41: ASSEMBLING THE LEFT REAR SUSPENSION



The rear left upright assembly should now look like this.

STEP 2

Take the **radius arm (41D)** and align the slightly bent end of it with the **bracket (41E)** as shown. Fit the arm over the bracket then fix the parts together using a **KM** screw. The link should be loose enough to rotate.

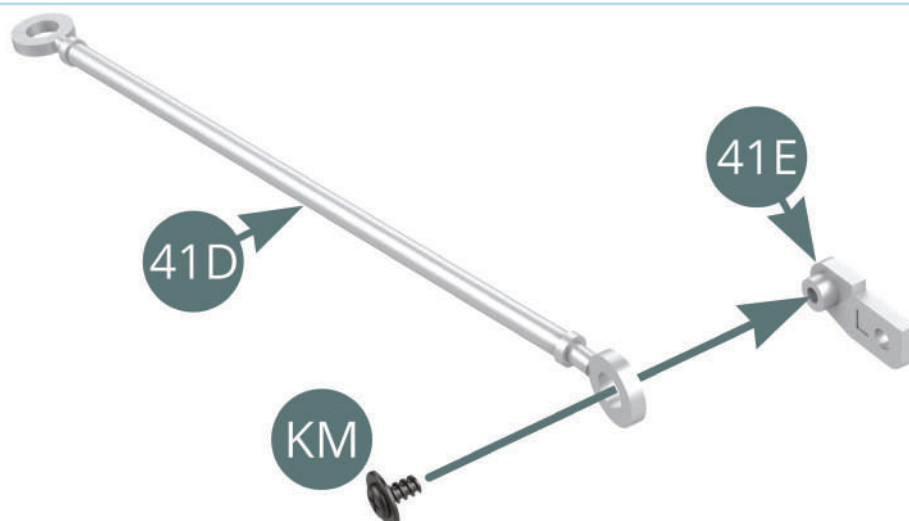

STEP 3

Push the **bracket (41G)** into the **left side frame (38A)** in the orientation shown then secure with a **BM** screw.

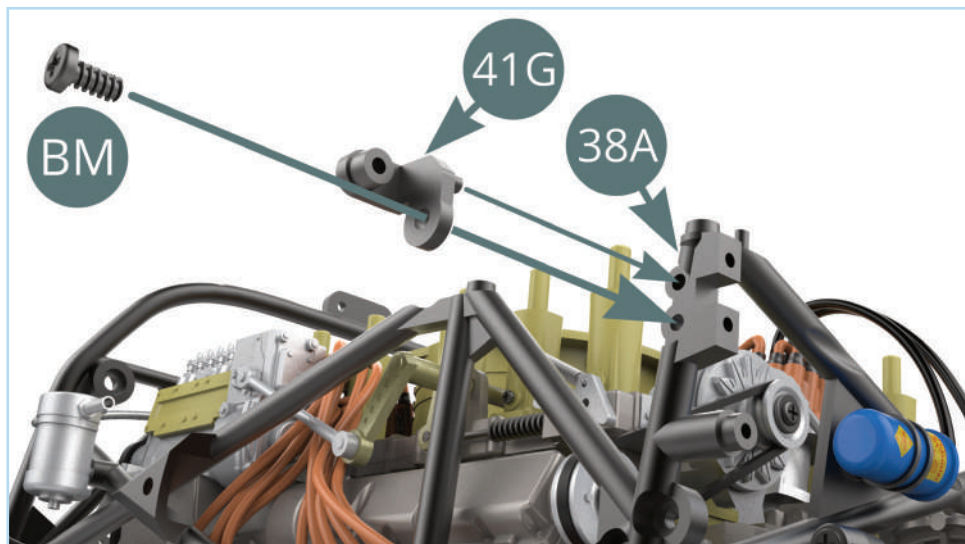

STAGE 41: ASSEMBLING THE LEFT REAR SUSPENSION

STAGE COMPLETE

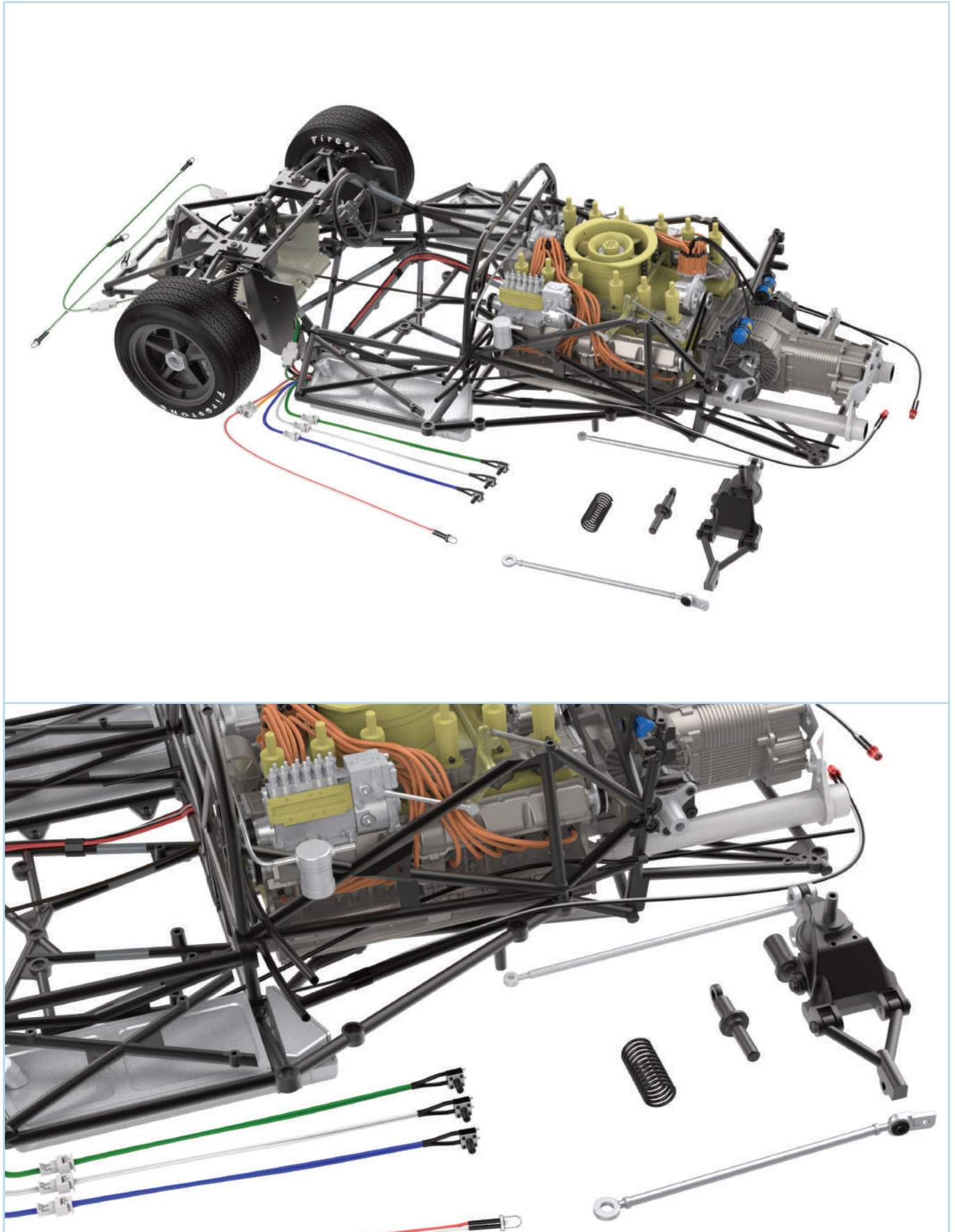

STAGE 42: ASSEMBLING THE RIGHT REAR SUSPENSION

42A Rear right upright

42B Radius arm with upper link

42C Bottom wishbone

42D Radius arm

42E Bracket

42F Shock absorber piston

42G Bracket

42H Shock absorber cylinder

42I Shock absorber spring

BM Screw 2.0 x 4 mm (x2)

CM Screw 2.0 x 3 x 5 mm (x2)

DM Screw 2.0 x 8 mm (x3)

KM Screw 1.7 x 3 x 5 mm (x2)

NM Screw 2.0 x 7 mm (x2)

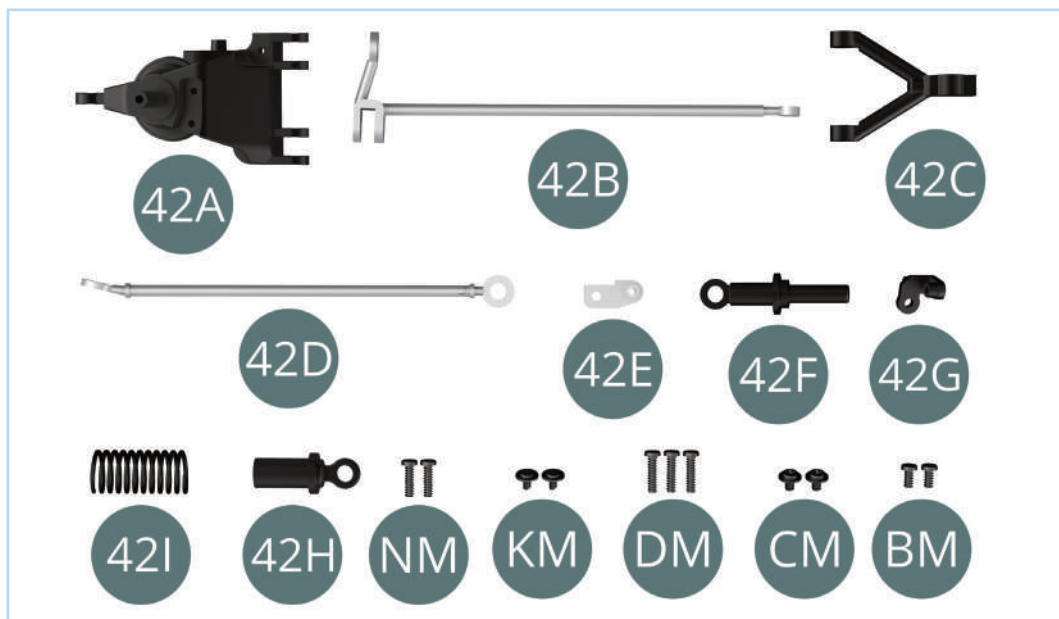

ASSEMBLY DIAGRAM

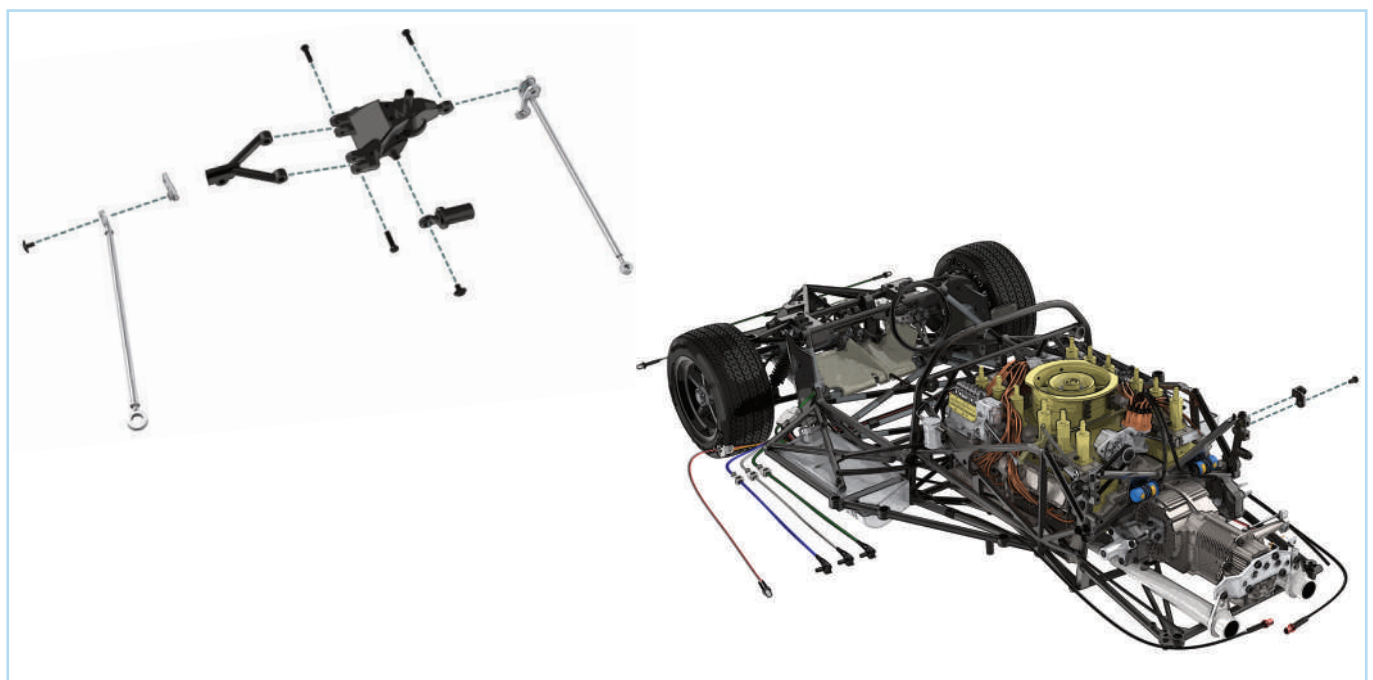

STAGE 42: ASSEMBLING THE RIGHT REAR SUSPENSION

STEP 1

Take the **bottom wishbone (42C)** and align it with the **rear right upright (42A)** as shown. Fit the parts together then fix using two **DM** screws.

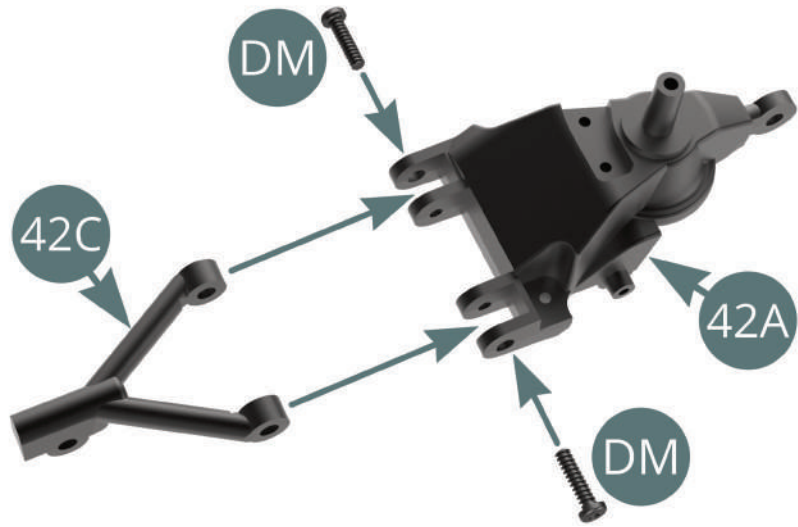

Fix the **shock absorber cylinder (42H)** onto the side of the **rear right upright (42A)** using a **CM** screw. Don't overtighten the screw, the cylinder should be able to move freely.

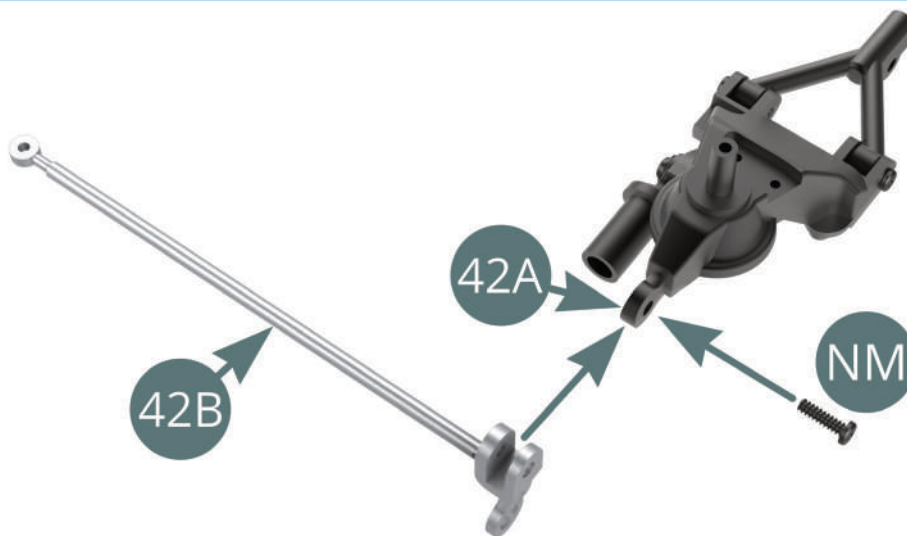
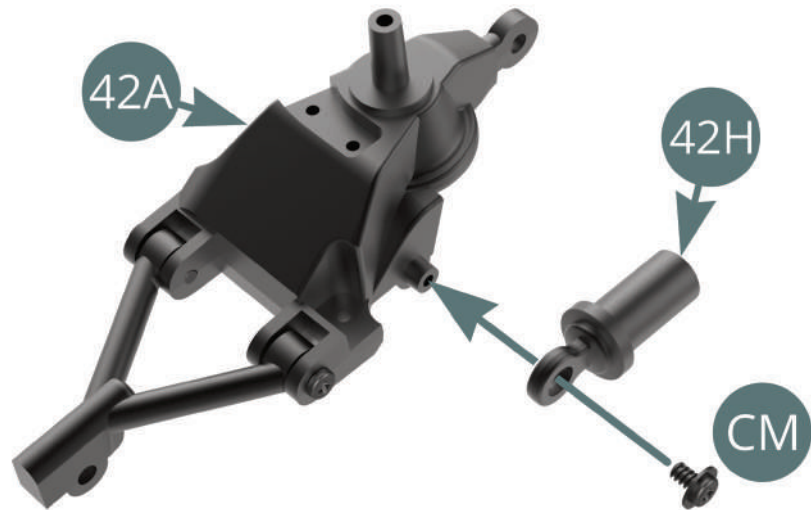

Align the **radius arm with upper link (42B)** to the **rear right upright (42A)** as shown then fit it in place and secure using an **NM** screw.

STAGE 42: ASSEMBLING THE RIGHT REAR SUSPENSION

The rear right upright assembly should now look like this.



STEP 2

Align the slightly bent end of the **radius arm (42D)** with the **bracket (42E)** as shown, then fit the end of the arm onto the bracket and fix in place using a **KM** screw. Leave the screw loose enough so that the link can rotate.



STEP 3

Push the **bracket (42G)** into the **right side frame (39A)** as shown then secure with a **BM** screw.

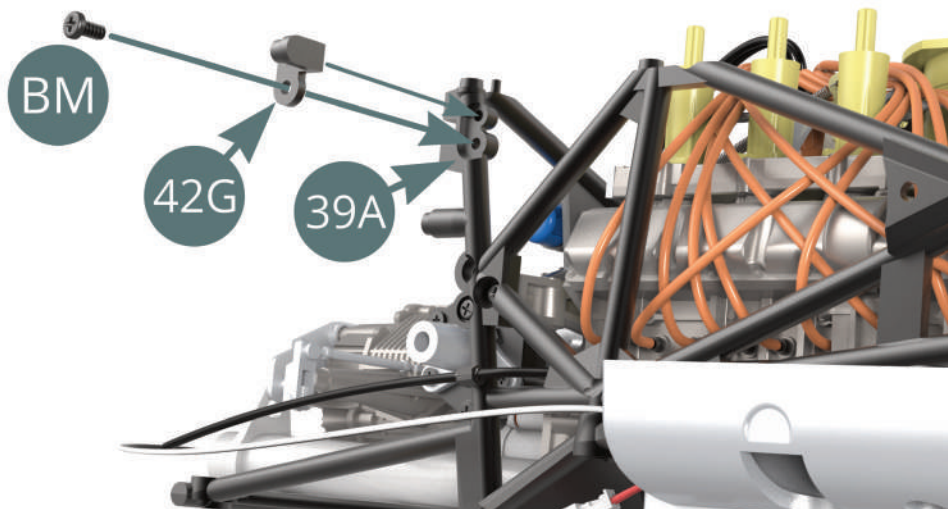

STAGE 42: ASSEMBLING THE RIGHT REAR SUSPENSION

STAGE COMPLETE

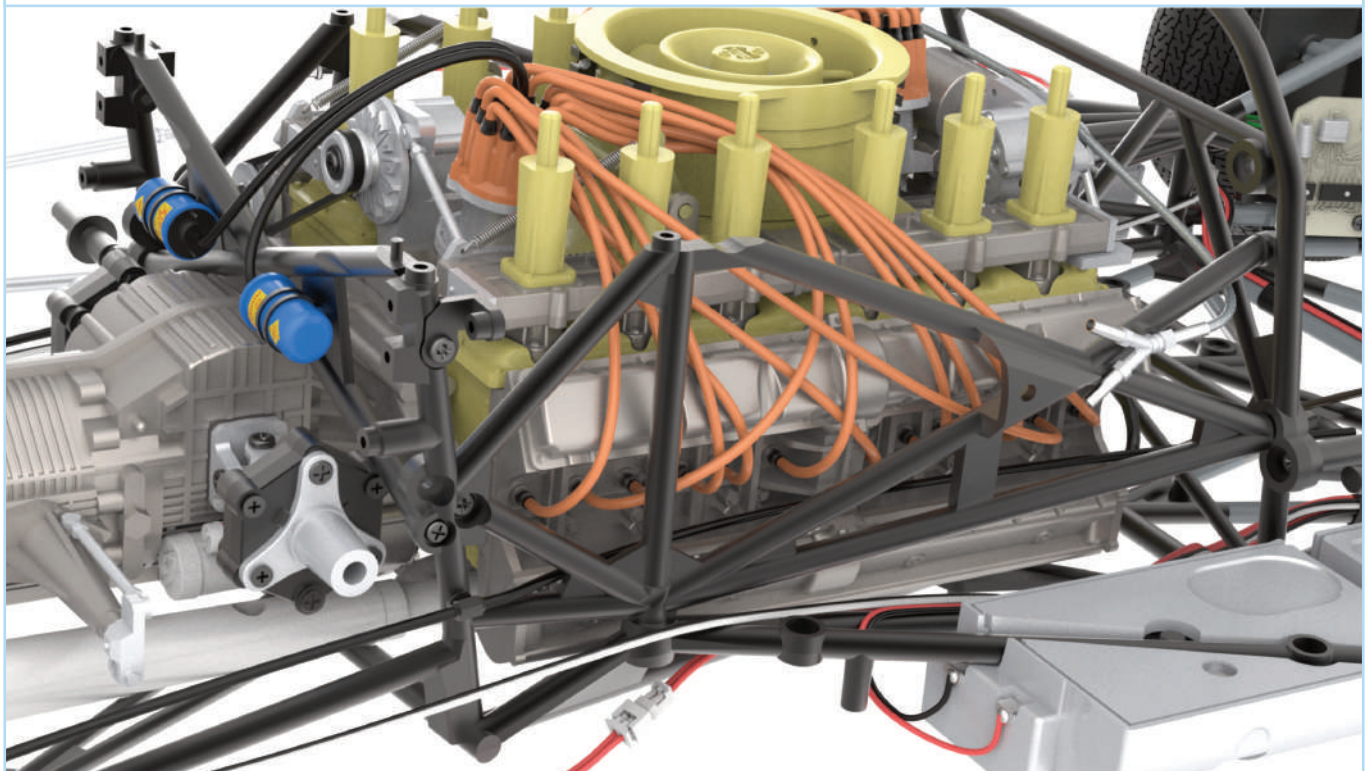
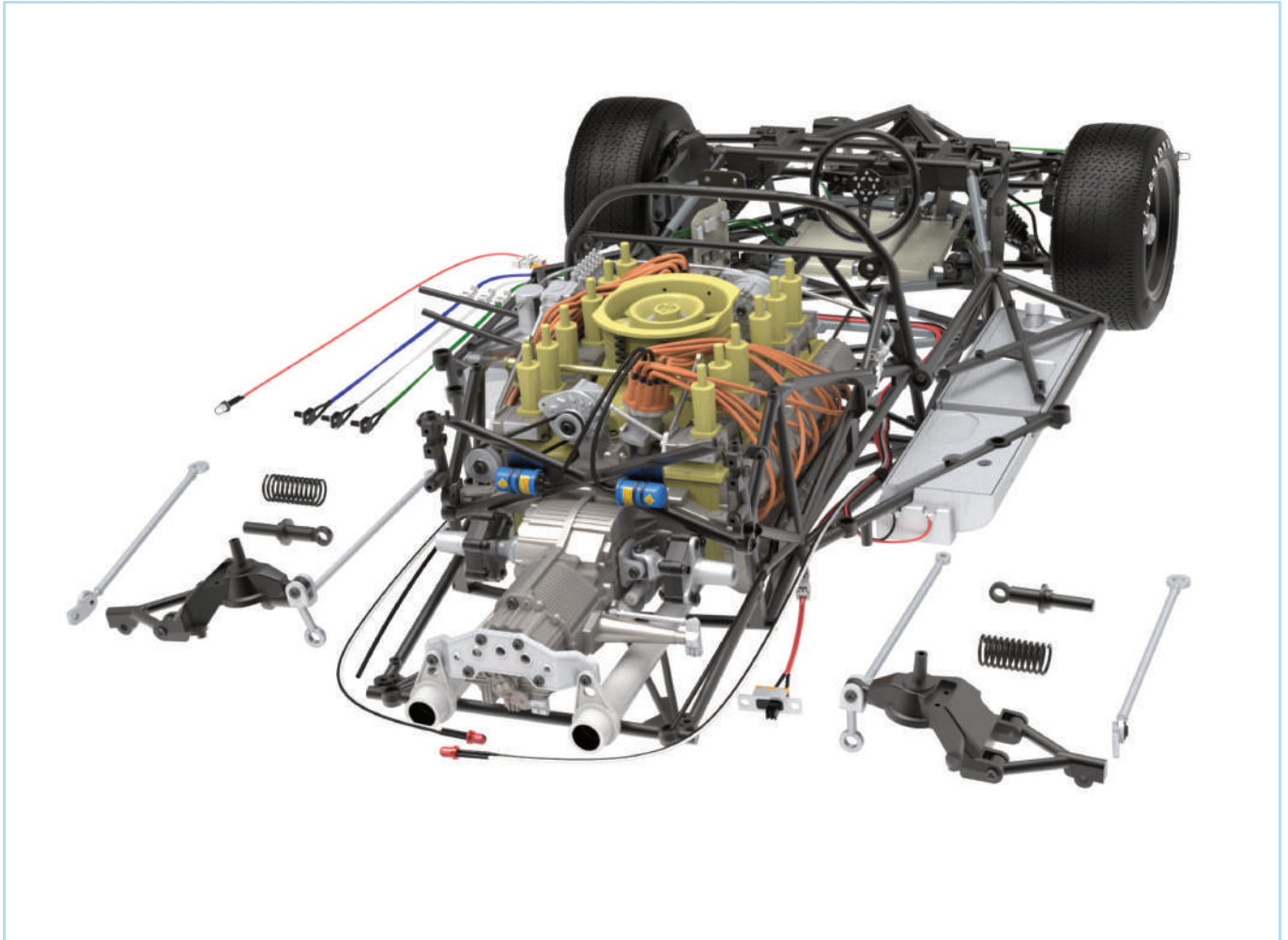

STAGE 43: INSTALLING THE REAR AXLE AND THE SUSPENSION

43A Rear axle

43B Drop links (x2)

43C Rear anti-roll bar

43D Plate bracket (x2)

43E Half shaft (x2)

43F Half shaft (x2)

43G Universal joint (x2)

EM Screw 2.0 x 9 mm (x3)

IM Screw 1.7 x 3.5 mm (x16)

JM Screw 2.0 x 5 mm (x6)

KM Screw 1.7 x 3 x 5 mm (x5)

OM Screw 2.0 x 4 x 5 mm (x5)

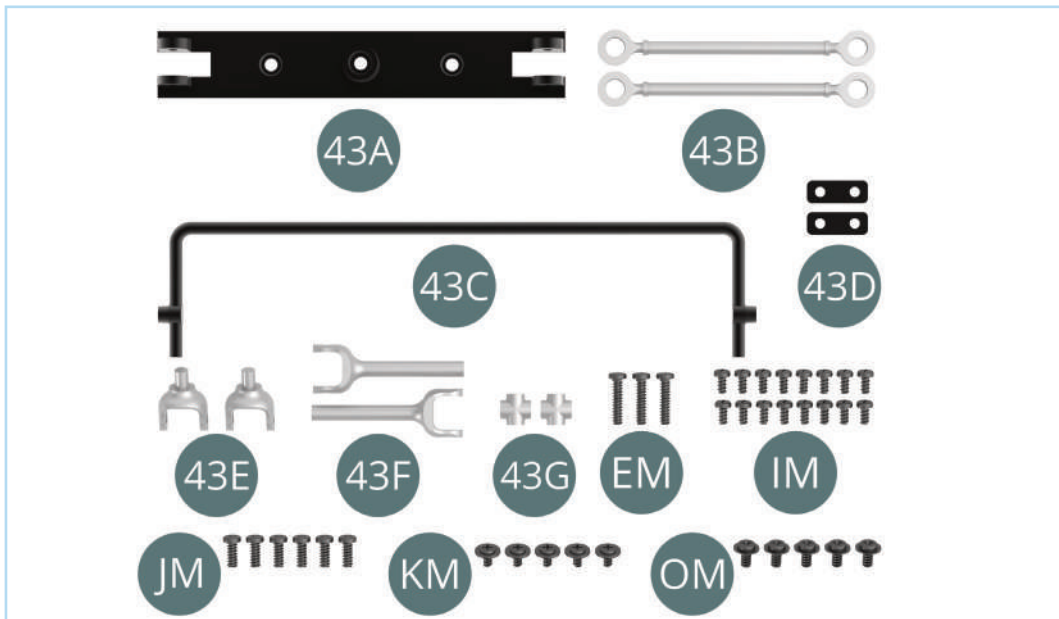

ASSEMBLY DIAGRAM

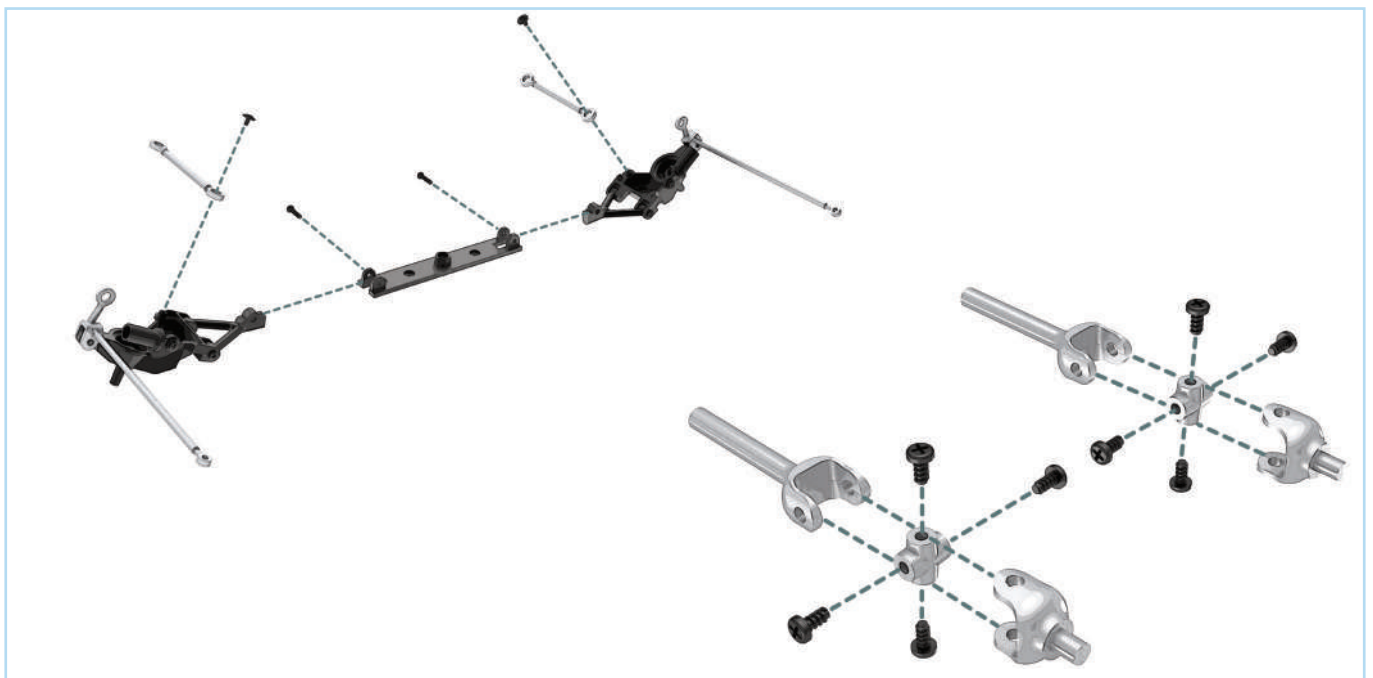

STAGE 43: INSTALLING THE REAR AXLE AND THE SUSPENSION

ASSEMBLY DIAGRAM

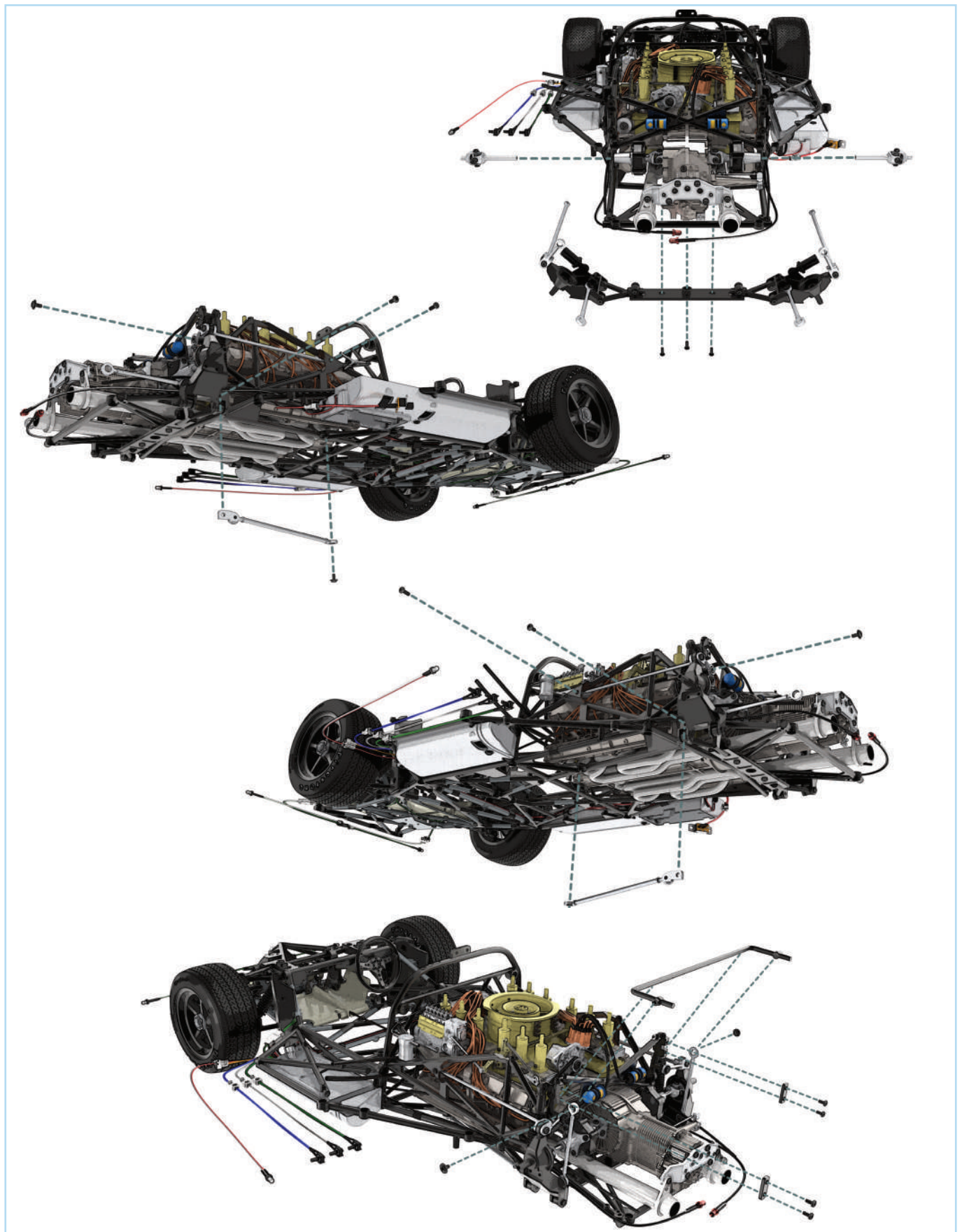

STAGE 43: INSTALLING THE REAR AXLE AND THE SUSPENSION

STEP 1

Take the rear left upright assembly from Stage 41 and fit a **drop link (43B)** onto the upright as shown. Secure in place using a **KM** screw.

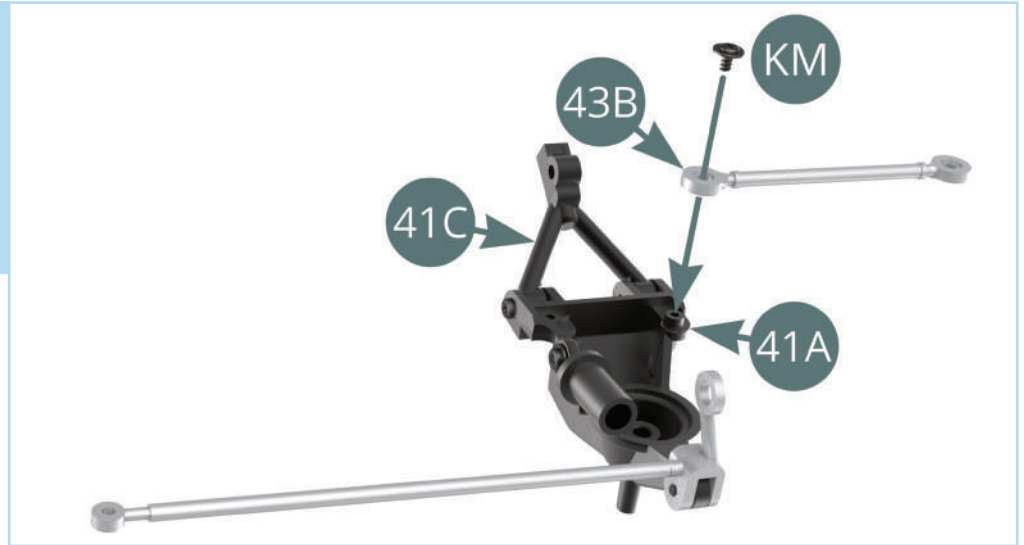

Fit the other **drop link (43B)** onto the rear right upright assembly from Stage 42 and secure with another **KM** screw.

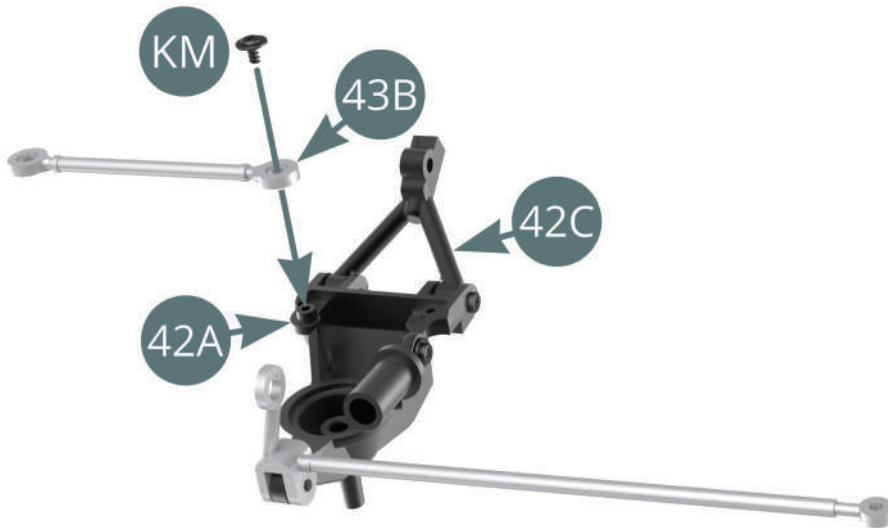

STEP 2

Take the rear left upright assembly and align it with the **rear axle (43A)** as shown. Fit the **bottom wishbone (41C)** into the axle and secure using an **EM** screw.

The axle has ridges, shown here in orange, for fitting it to the chassis. Align the axle and the upright assembly as shown.

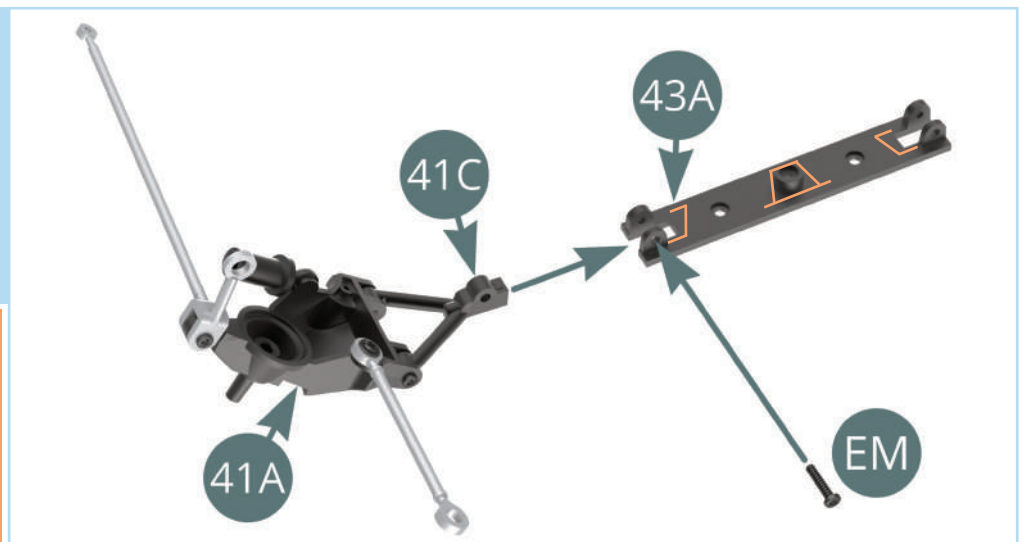

STAGE 43: INSTALLING THE REAR AXLE AND THE SUSPENSION

Next fit the **bottom wishbone (42C)** of the rear right upright assembly into the other side of the axle and secure using an **EM** screw.

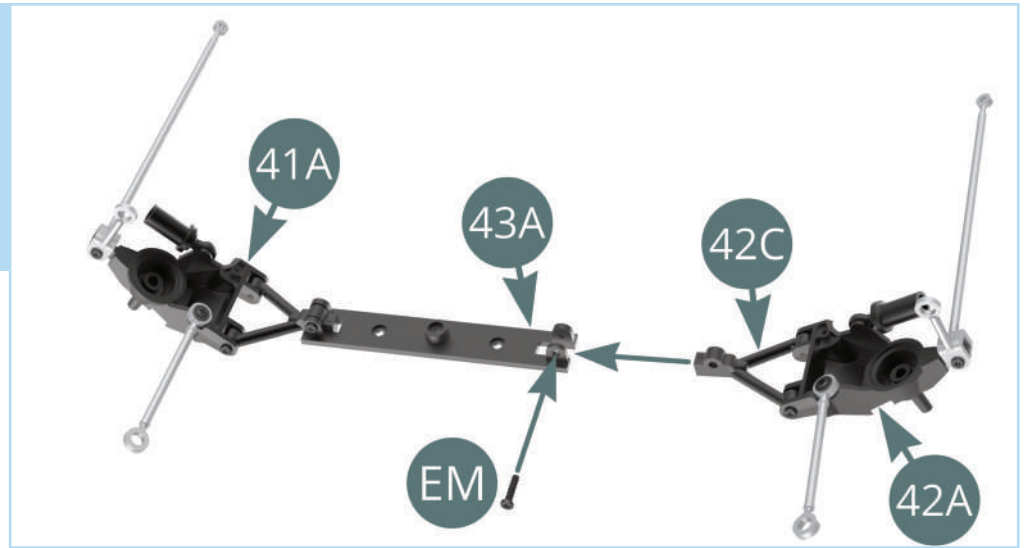

STEP 3

You'll now assemble two half shafts. First, fit the **universal joints (43G)** into the longer **half shafts (43F)** and fix them in place using two **IM** screws.

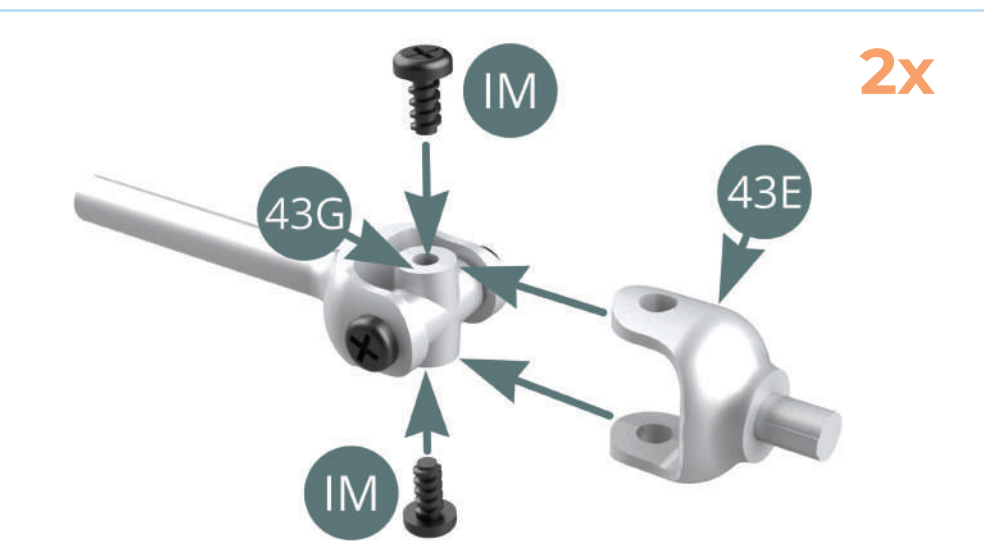
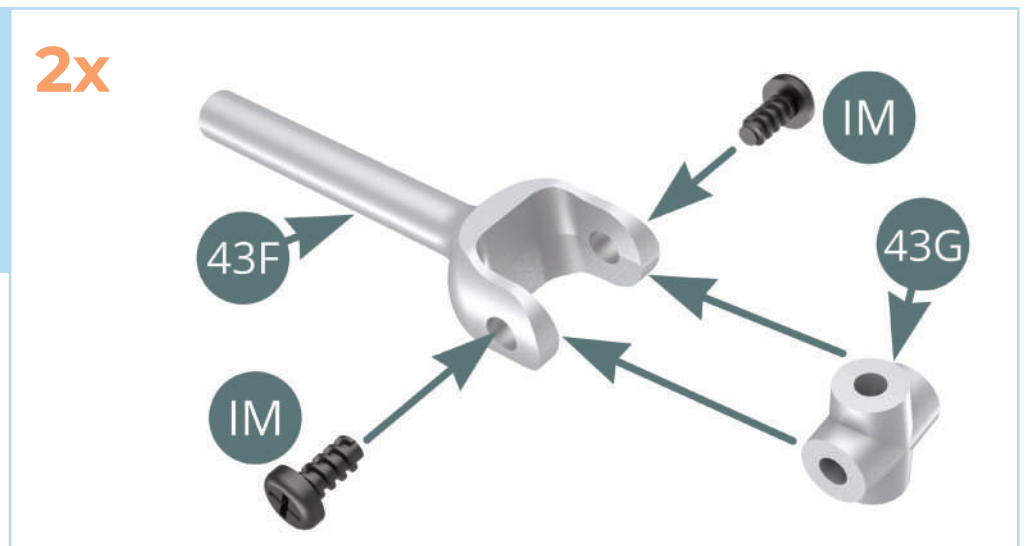

Take the shorter **half shafts (43E)** and position them over the **universal joints (43G)** before securing each in place using two more **IM** screws.

STAGE 43: INSTALLING THE REAR AXLE AND THE SUSPENSION

STEP 4

Place the chassis assembly upside down on your work surface. Take the rear axle assembly and align it with the underside closest to the exhausts. Using the ridges highlighted in step 2, fit the **rear axle (43A)** onto the **chassis (25A)** then secure it to the **gearbox underside (5A)** using a **JM screw**.

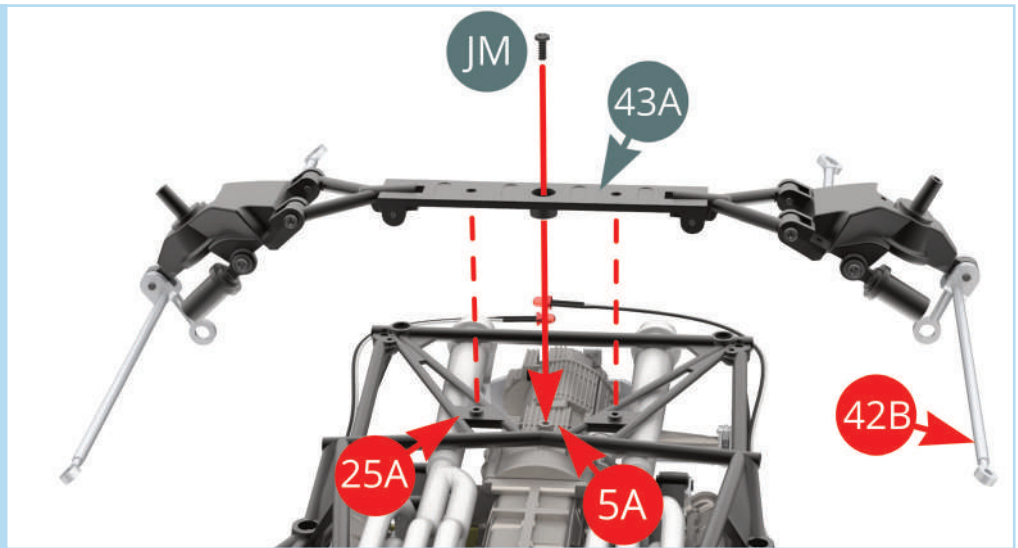

Turn the assembly over and fit the two **half shafts (43F)** into the **cardan sockets (4H and 6H)**.

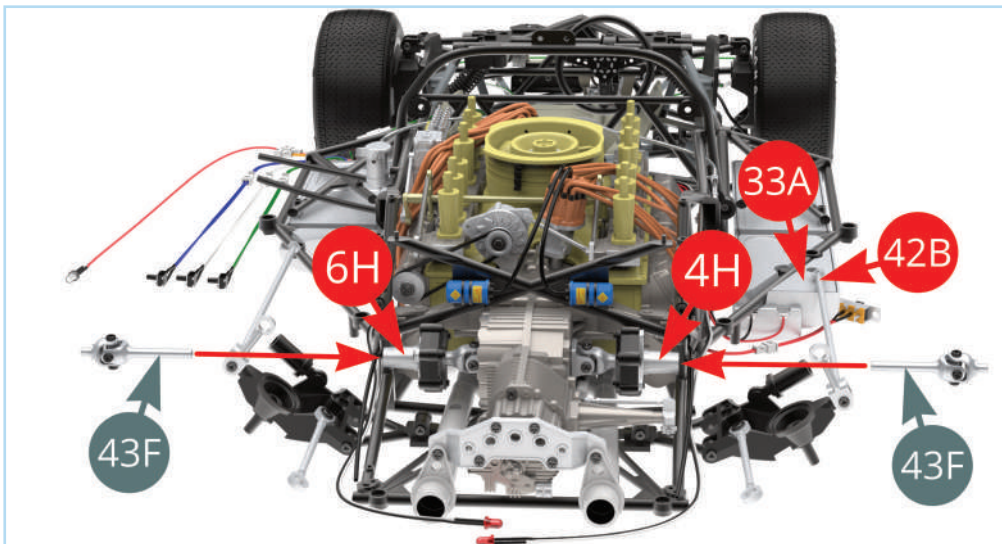

STEP 5

Lift the **rear left upright (41A)** and fit it over the **half shaft (43E)** as shown by the blue arrow. At the same time, fit connections of the **radius arm (41B)** inside the enclosure (orange arrow) and over the screw hole (green arrow) located on the **left side frame (38A)**.

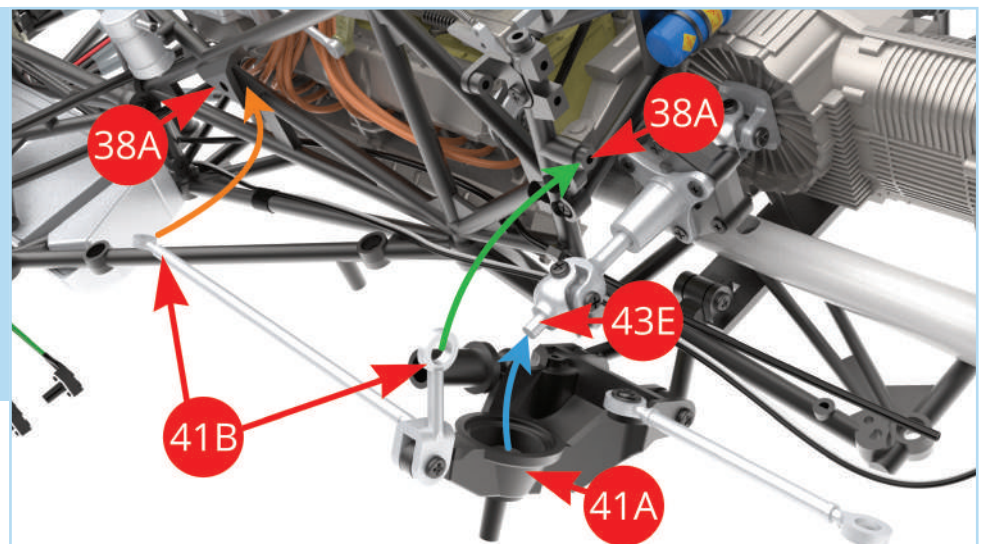

STAGE 43: INSTALLING THE REAR AXLE AND THE SUSPENSION

Use a **JM** screw to fix the **radius arm (41B)** to the **left side frame (38A)** from the side and an **OM** screw to secure it from the rear, as shown in the image.

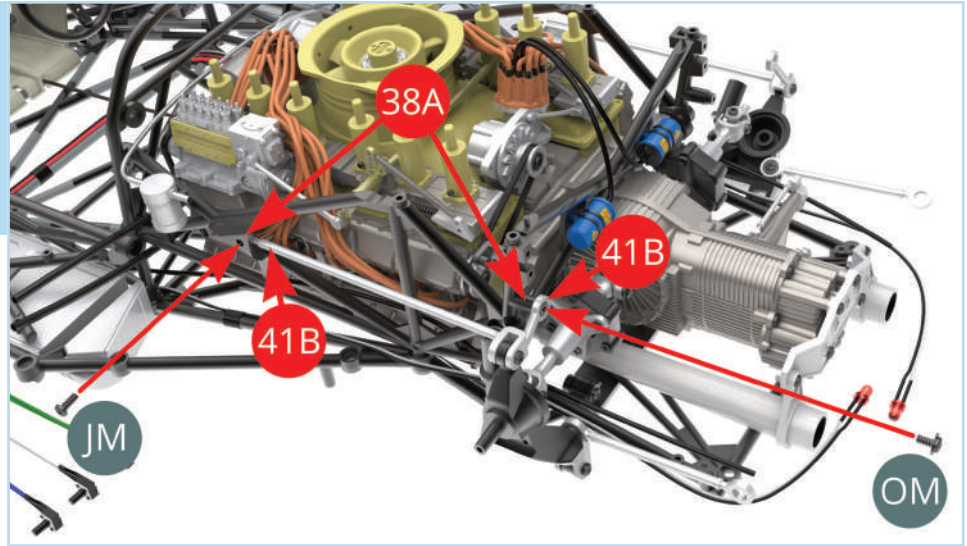

STEP 6

Repeat the same process as before by lifting the **rear right upright (42A)** into place and fitting the connections of the **radius arm (42B)** to the **right side frame (39A)**.

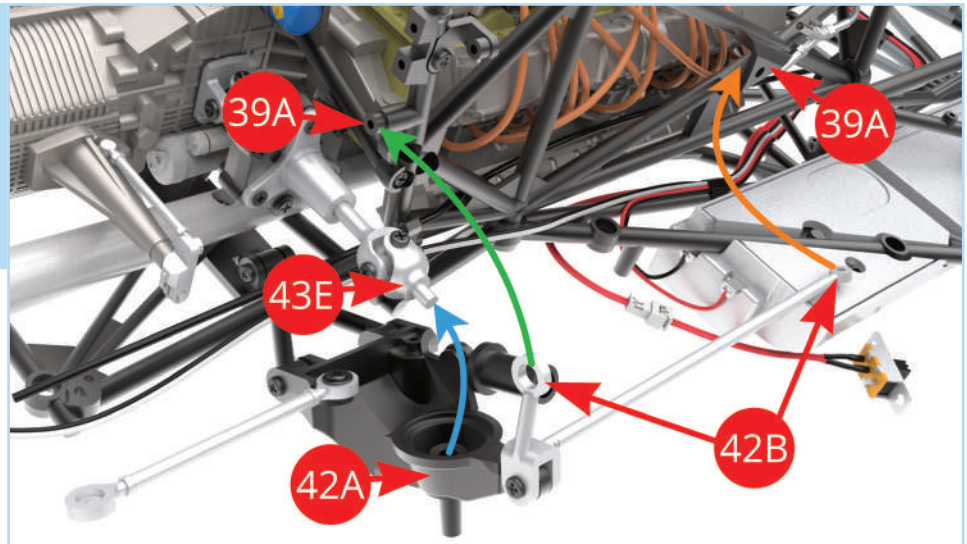

Use a **JM** screw and an **OM** screw to fix the **radius arm (42B)** to the **right side frame (39A)** as shown.

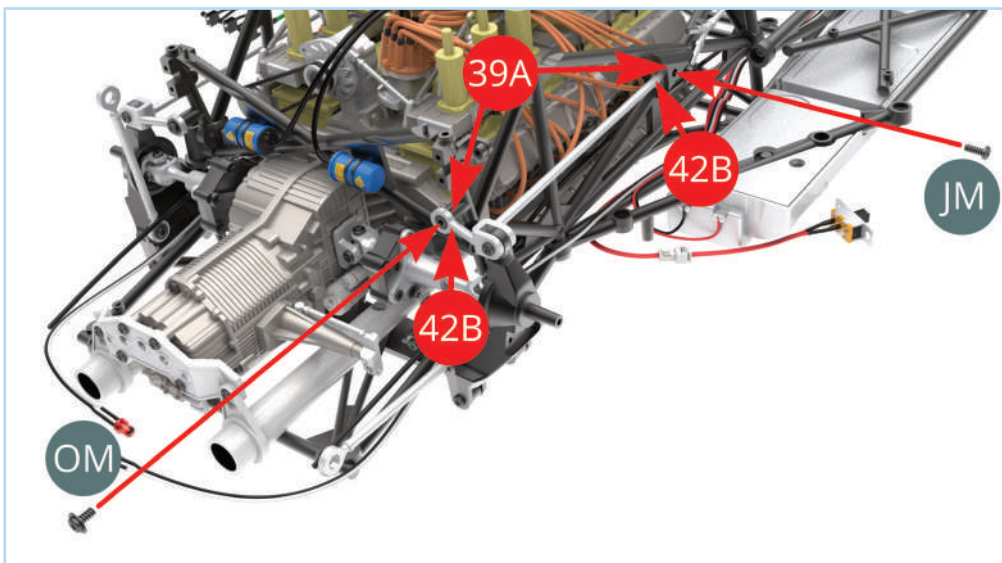

STAGE 43: INSTALLING THE REAR AXLE AND THE SUSPENSION

STEP 7

Carefully turn the assembly back over and secure the **rear axle (43A)** to the **chassis (25A)** using two **JM** screws.

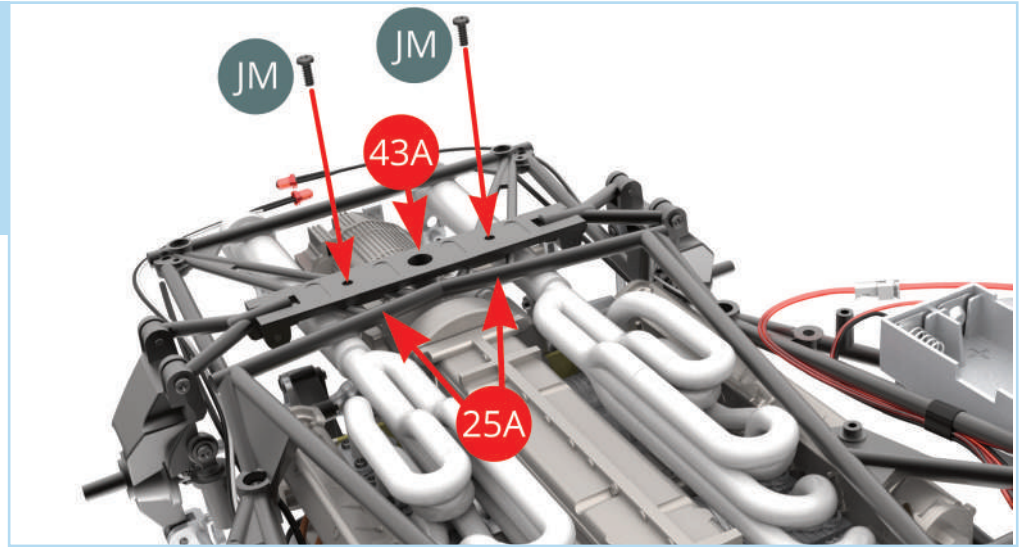

Turn the assembly back over. Still working on the underside of the chassis, take the radius arm assembly from Stage 41. Fit the **radius arm (41D)** to the **chassis (25A)** and the **bracket (41E)** to the **left rear upright (41A)**. Secure in place using an **OM** and an **IM** screw as shown.

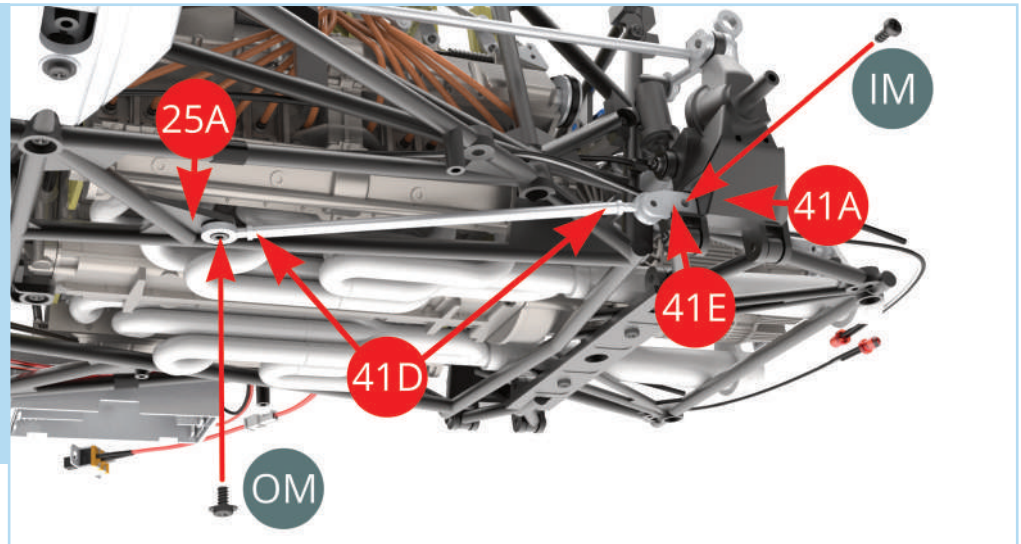

Note: the radius arms have an 'L' and an 'R' on the shaft, closest to the link opposite the bracket.

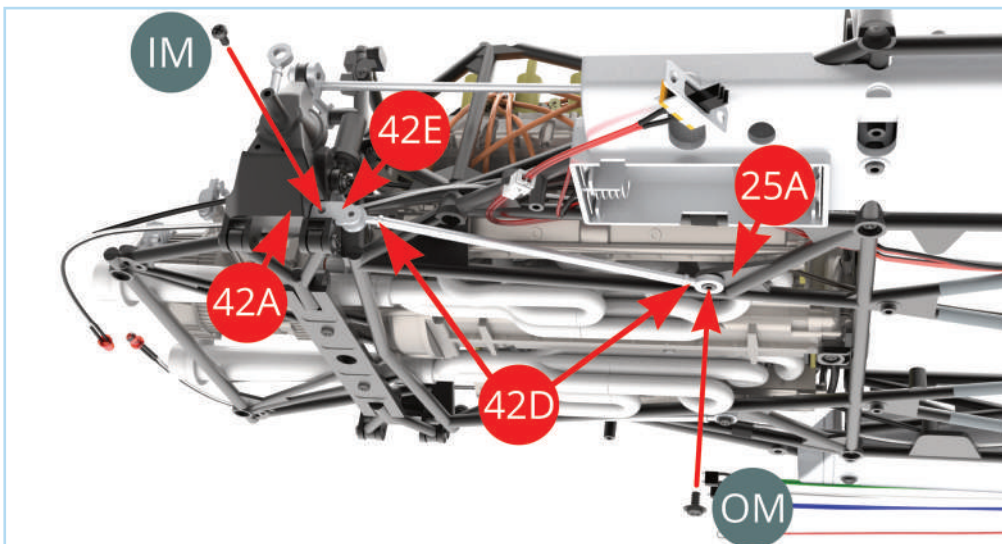

Then take the radius arm assembly from Stage 42 and fix it to the other side in the same way using an **IM** and an **OM** screw.

STAGE 43: INSTALLING THE REAR AXLE AND THE SUSPENSION

STEP 8

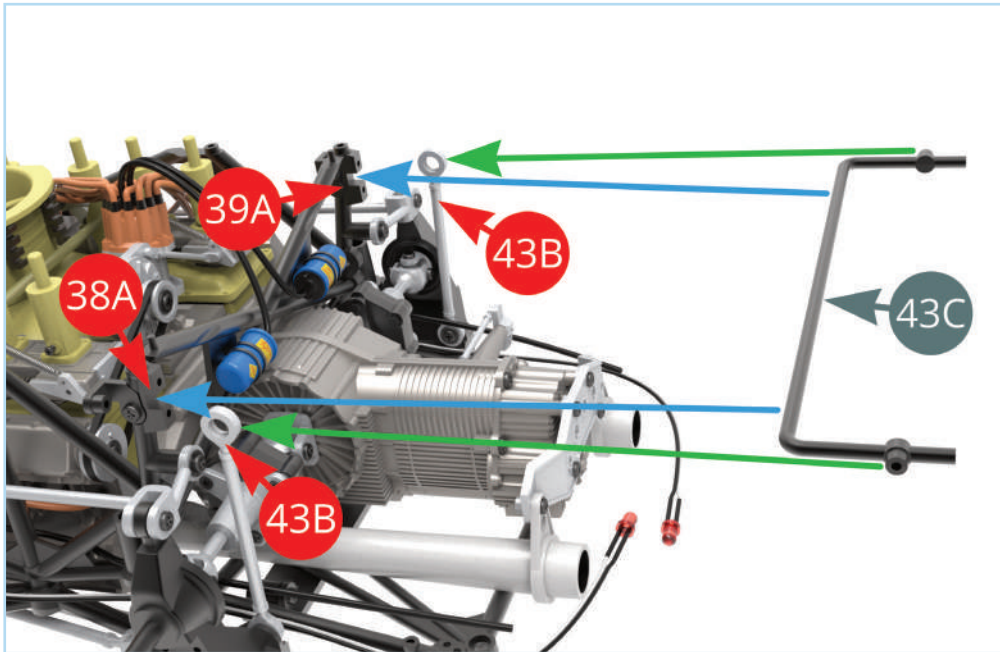

Push the **rear anti-roll bar (43C)** into the recesses on the side frames (**38A and 39A**) as shown by the blue arrows. Once in place, fit the eyelets of the **drop links (43B)** over the screw columns of the bar (green arrows).

Fit one of the **plate brackets (43D)** over the recess in the **left side frame (38A)** and fix together using two **IM** screws.

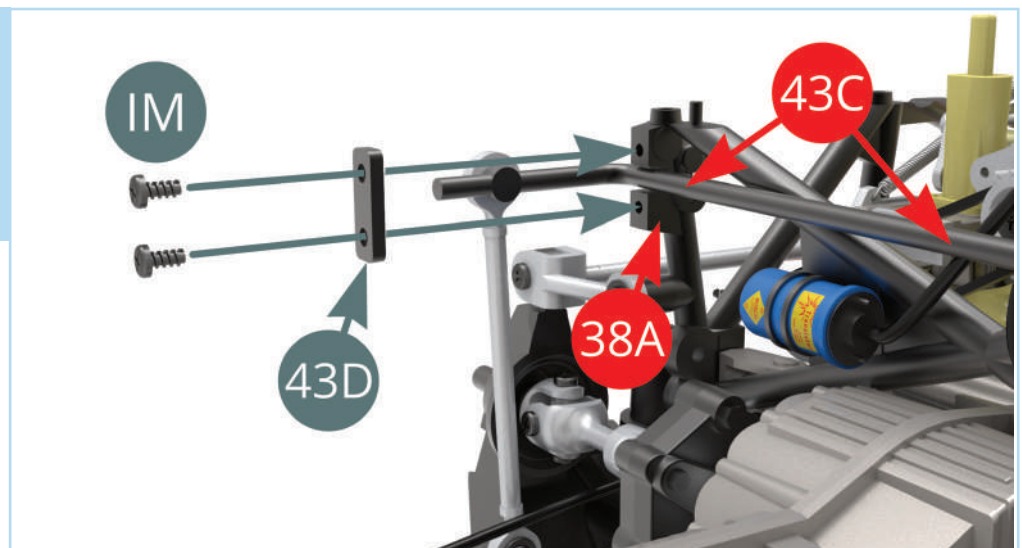

Fit the other **plate bracket (43D)** over the **right side frame (39A)** in the same way and secure with two more **IM** screws to hold the **rear anti-roll bar (43C)** in place.

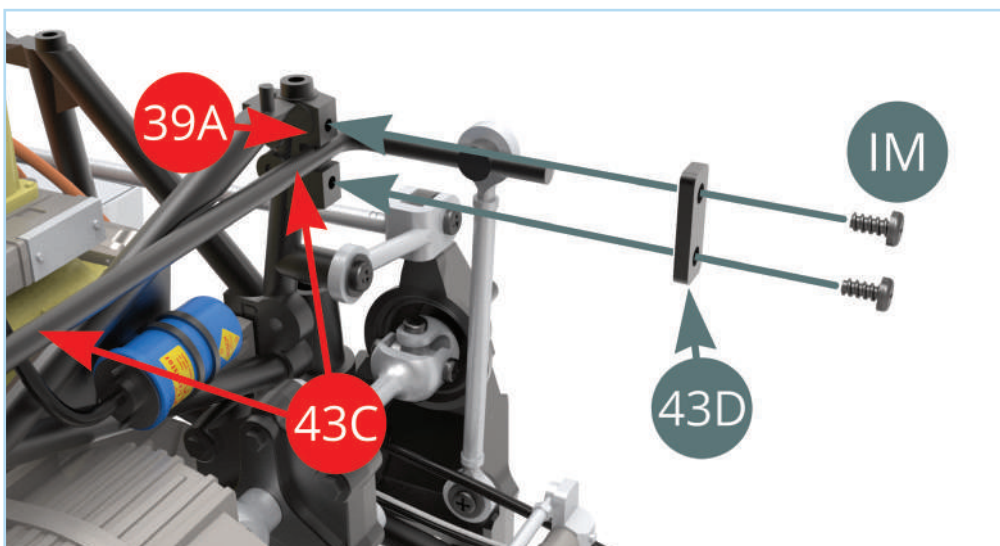

STAGE 43: INSTALLING THE REAR AXLE AND THE SUSPENSION

STEP 9

Use a **KM** screw to fix the left **drop link (43B)** to the **rear anti-roll bar (43C)**.

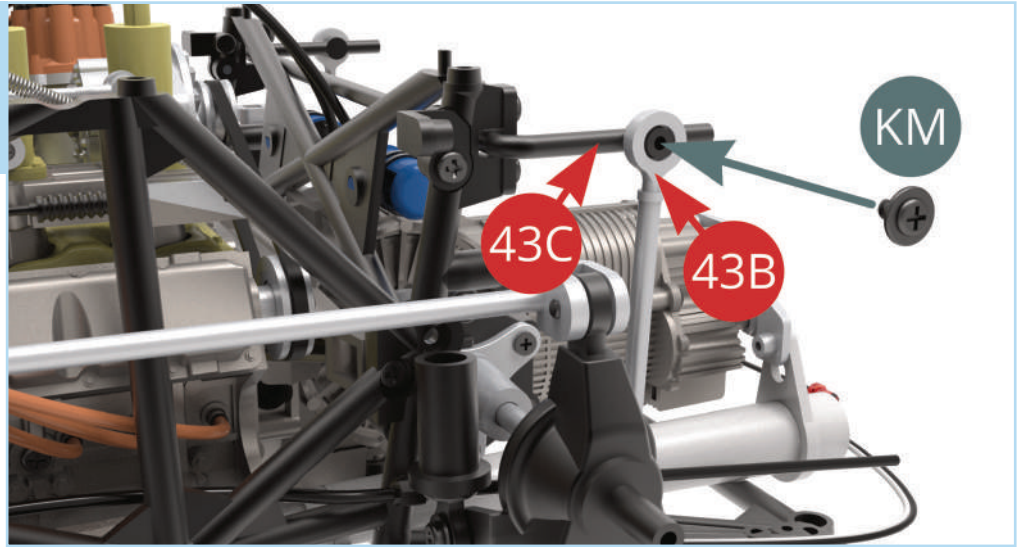

Repeat on the other side with another **KM** screw to secure the bar in place.

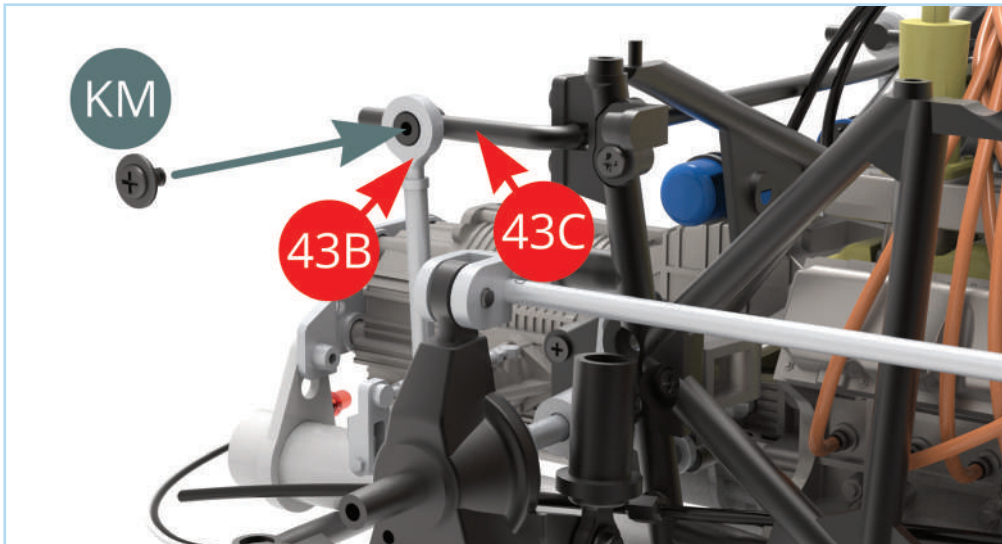

STAGE 43: INSTALLING THE REAR AXLE AND THE SUSPENSION

STAGE COMPLETE

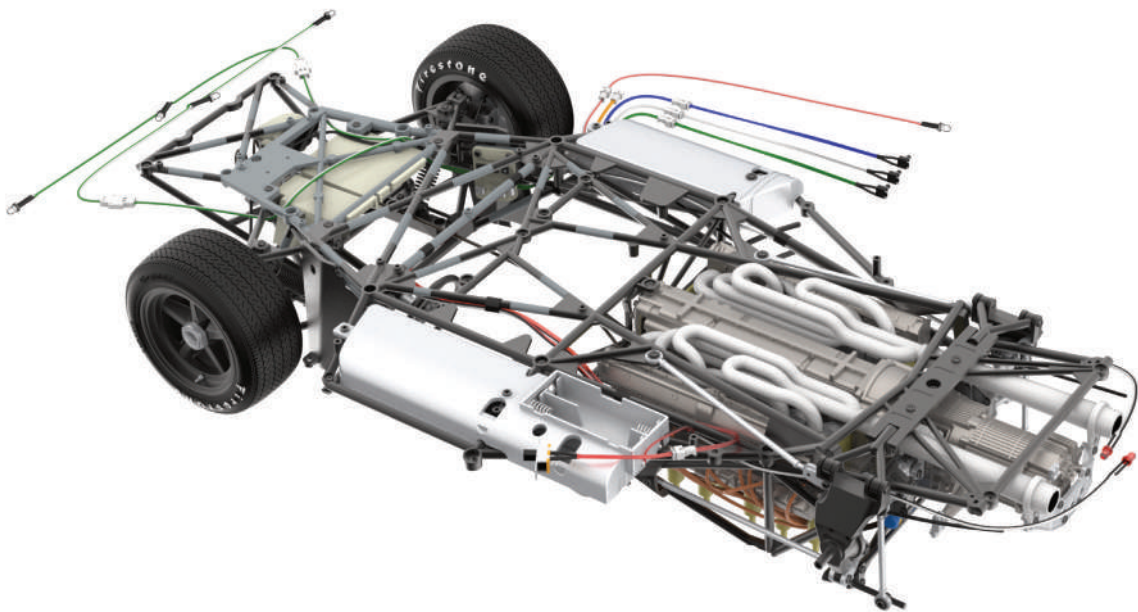
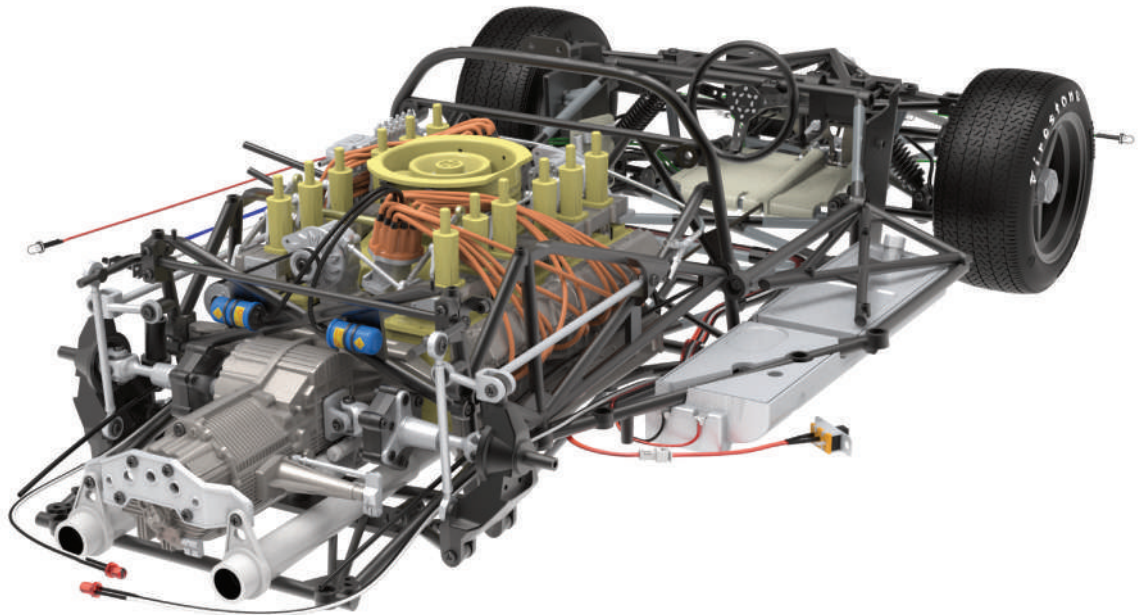

STAGE 44: BUILDING THE REAR BRAKE DISCS AND FITTING THE CALIPERS

44A Left brake caliper

44B Right brake caliper

44C Brake piston cover (x2)

44D Brake disc surface (red arrows indicate direction of ventilation holes, right) (x2)

44E Brake disc surface (blue arrows indicate direction of ventilation holes, left) (x2)

44F Brake disc rotor (inner half) (x2)

44G Brake disc rotor (outer half) (x2)

IM Screw 1.7 x 3.5 mm (x5)

CP Screw 1.7 x 3 x 3 mm (x5)

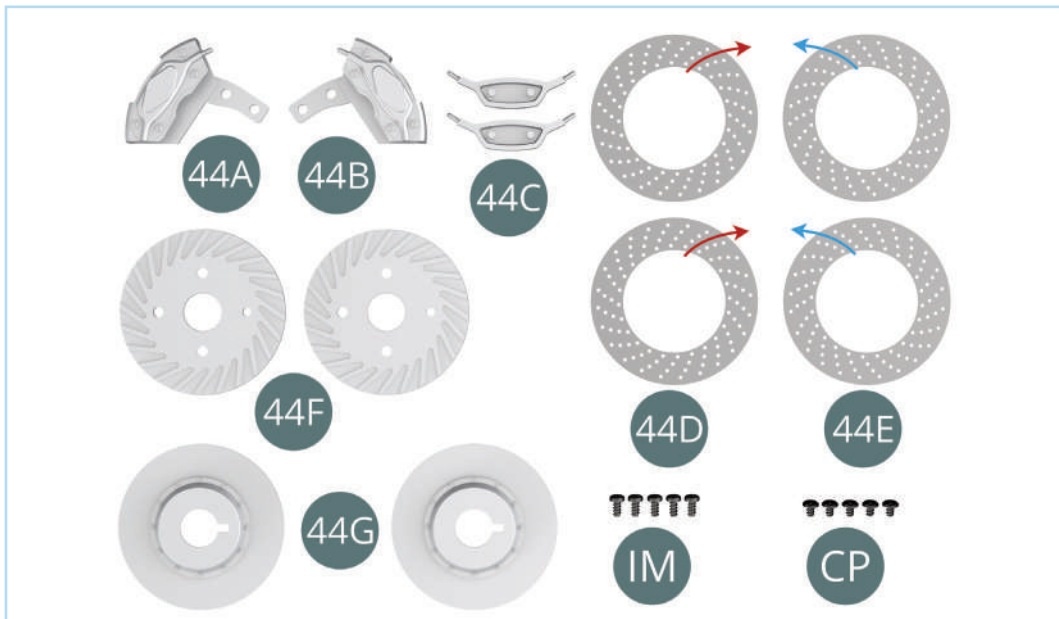

ASSEMBLY DIAGRAM

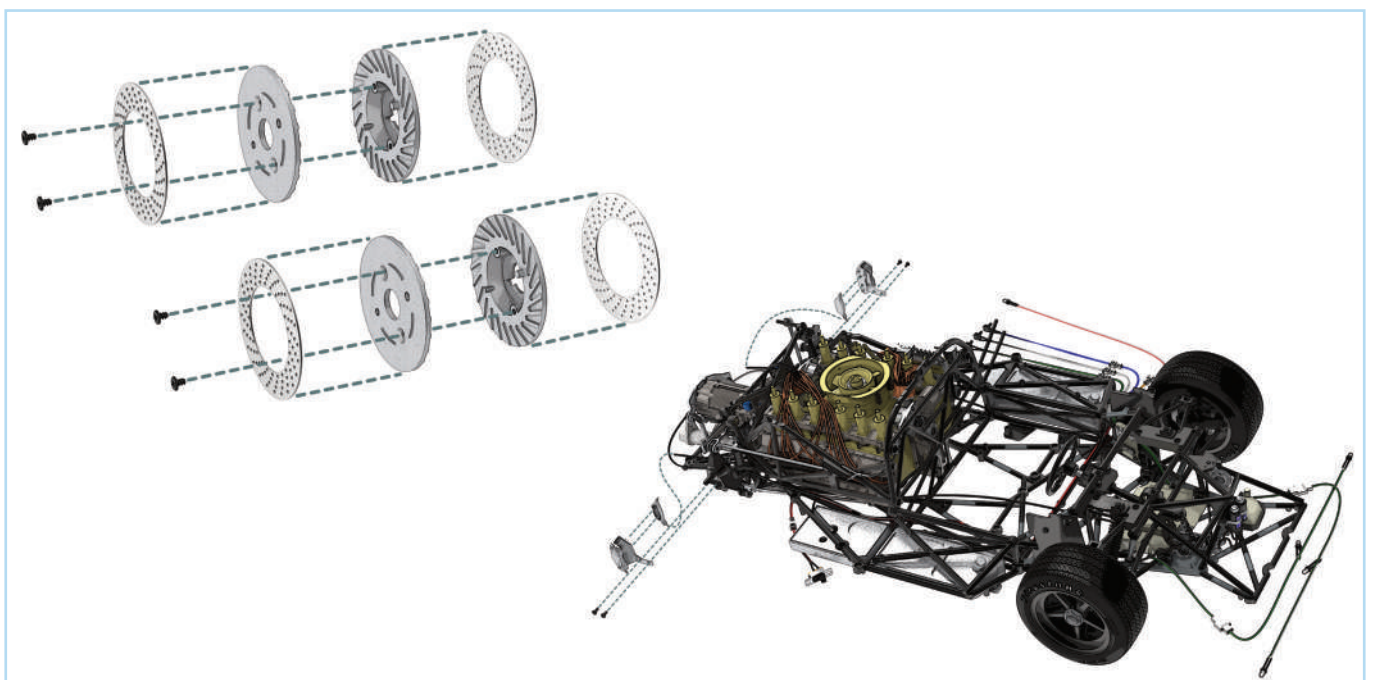

STAGE 44: BUILDING THE REAR BRAKE DISCS AND FITTING THE CALIPERS

STEP 1

Take one of the **brake disc surfaces (44E)** with the ventilation holes to the left (blue arrow). Peel the backing paper from it and stick it to one of the **brake disc rotors (inner half) (44F)** as shown. Ensure that the outer holes are in line with the raised ridge on the disc, as indicated by the orange arrows.

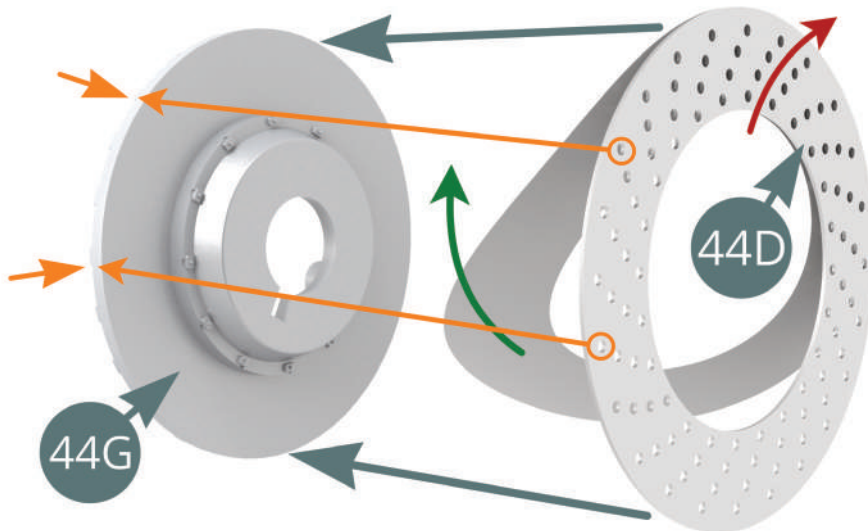
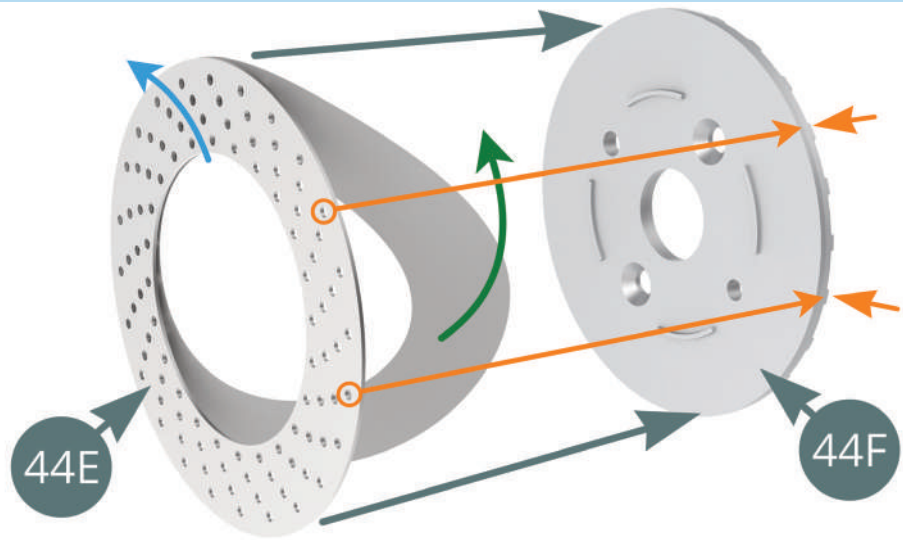

Then take one of the other **brake disc surfaces (44D)** with the holes to the right (red arrow) and peel its backing paper off. Stick this to one of the **brake disc rotors (outer half) (44G)**, again lining up the outer holes with the raised ridges.

Fit the two halves of the brake disc together by pressing the small and large pins (circled) into the corresponding holes. Fix the halves together using two **CP** screws.

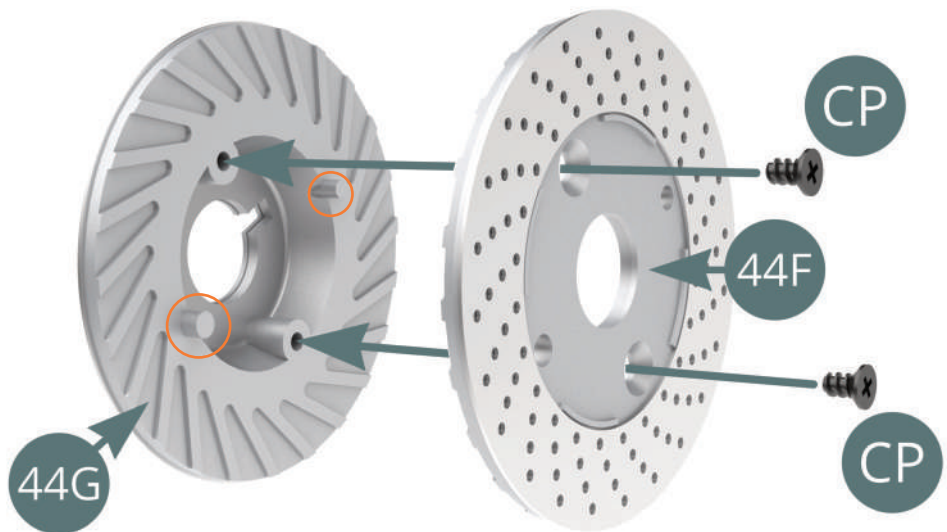

STAGE 44: BUILDING THE REAR BRAKE DISCS AND FITTING THE CALIPERS

STEP 2

You'll now repeat the steps to assemble the second brake disc but using alternate surfaces for each half. Take the remaining **brake disc surface (44D)** with the ventilation holes to the right (red arrow). Peel the backing paper from it and stick it to the remaining **brake disc rotor (inner half) (44F)** as shown.

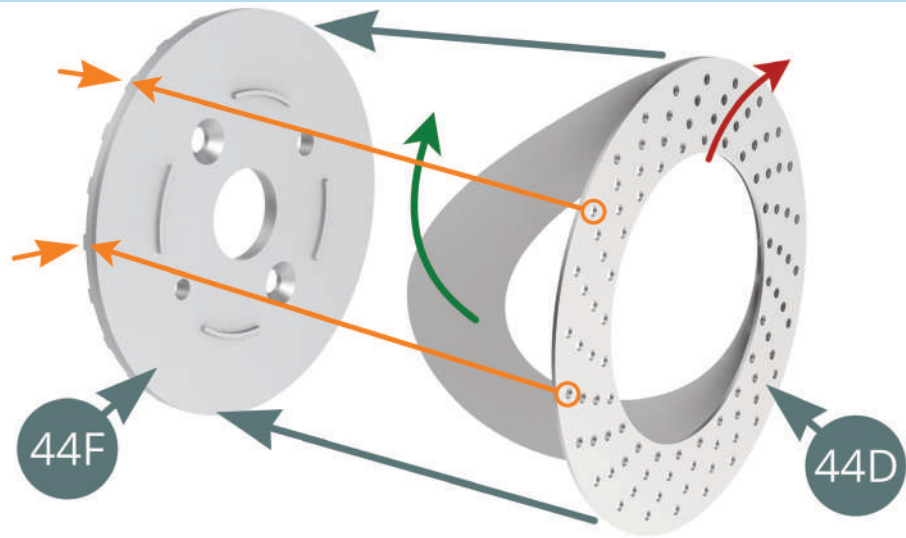

Take the last **brake disc surface (44E)** with the holes to the left (blue arrow) and stick it to the remaining **brake disc rotor (outer half) (44G)** in the same manner as before.

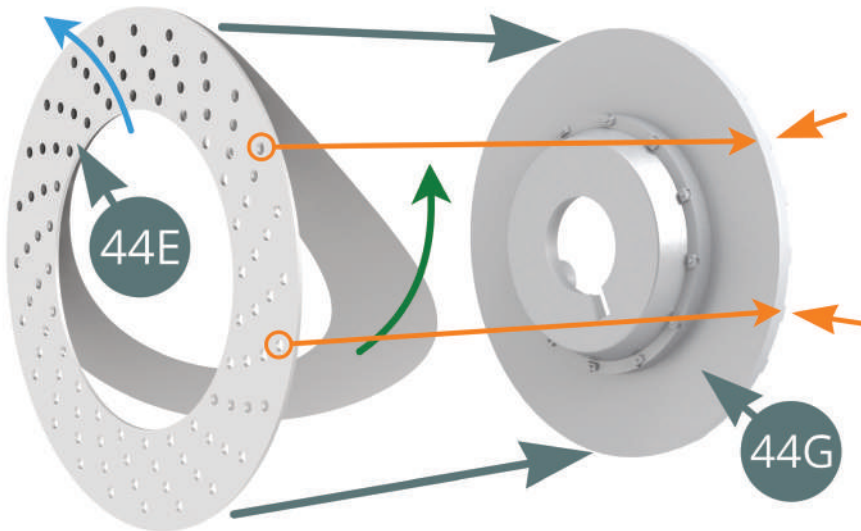

Fit the two halves together and secure using two **CP** screws.

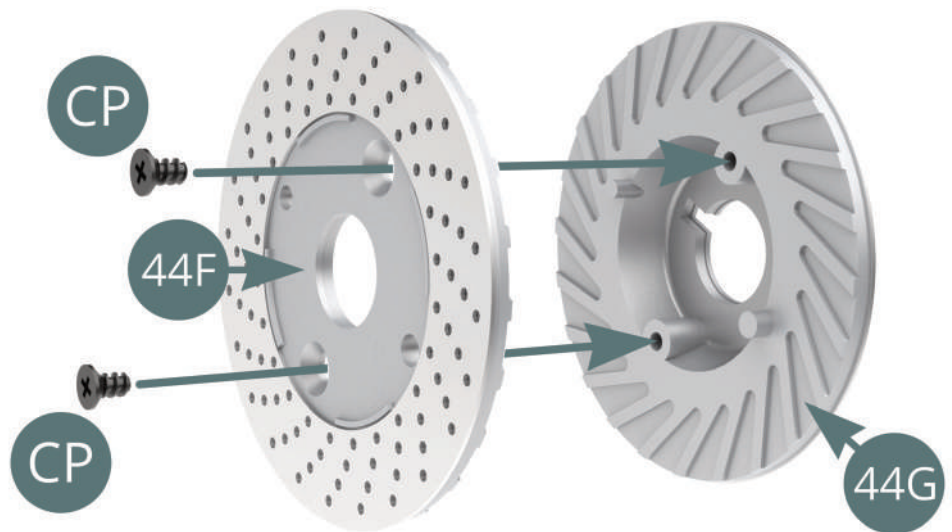

STAGE 44: BUILDING THE REAR BRAKE DISCS AND FITTING THE CALIPERS

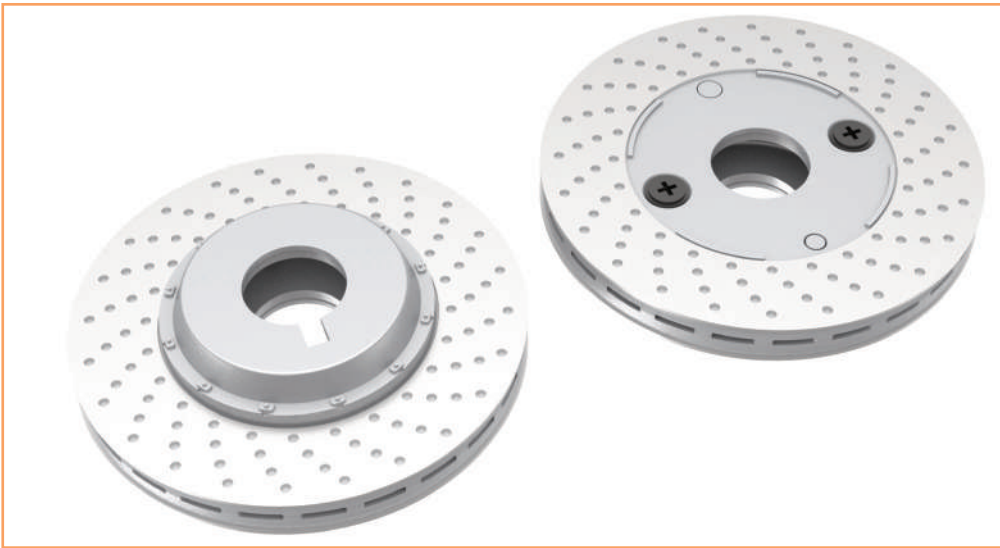

This image shows the two rear brake discs assembled correctly.

STEP 3

Take the two **brake piston covers (44C)** and align them with the left and right **brake caliper (44A and 44B)** as shown. Press the pins of the covers into the holes on the calipers. Note that each caliper is marked to help differentiate the left from right ('R', circled).

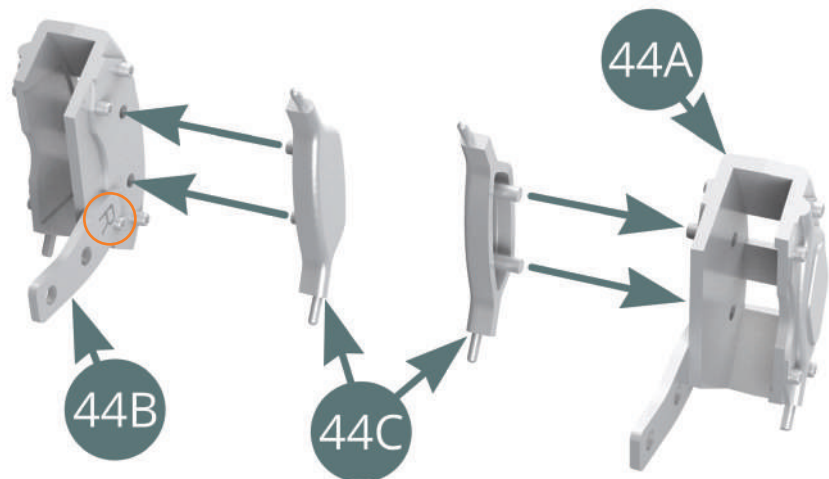

STEP 4

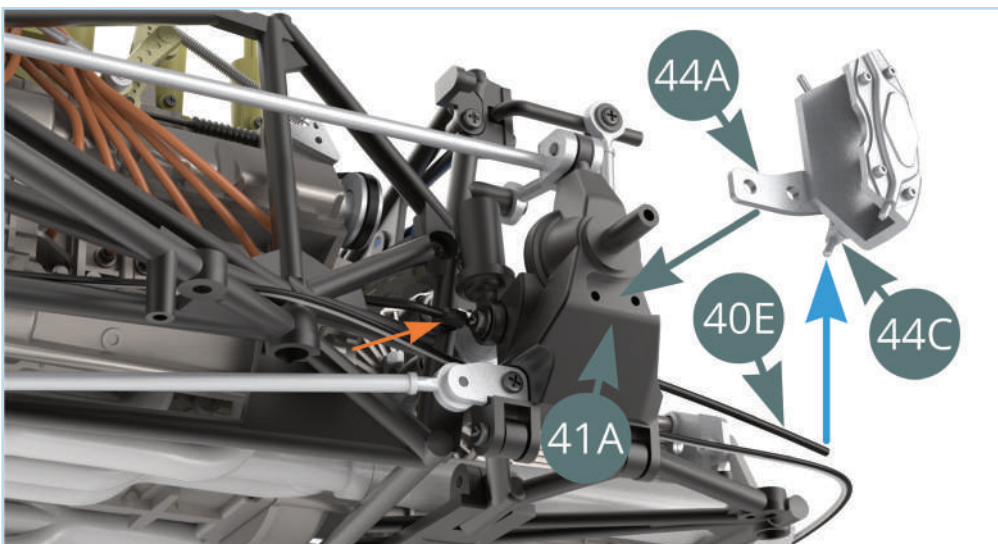

Connect the shorter **brake line (40E)** (leading from the connector, orange arrow) to the pin on the bottom of the **brake piston cover (44C)** as shown by the blue arrow, then position the **left brake caliper (44A)** onto the rear left upright (41A).

STAGE 44: BUILDING THE REAR BRAKE DISCS AND FITTING THE CALIPERS

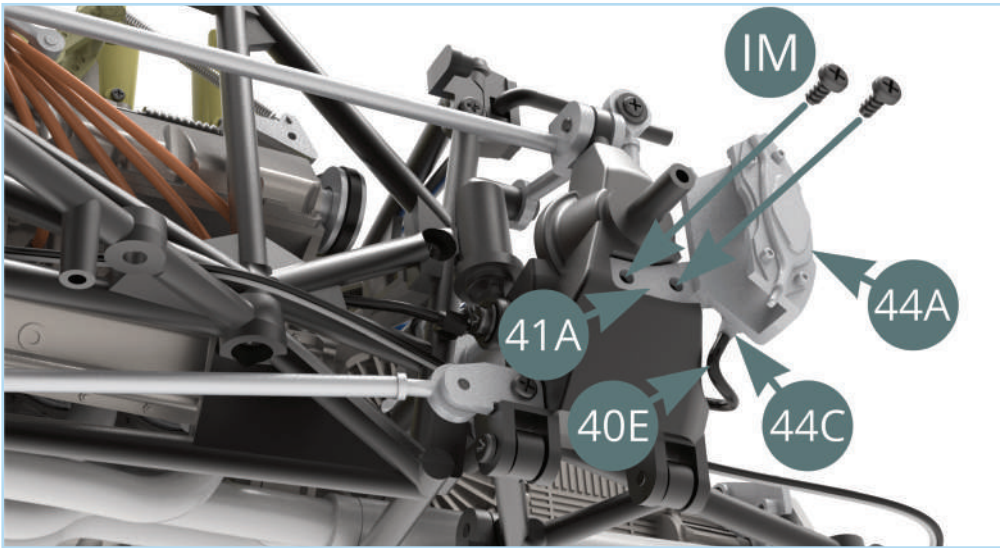

While holding it in place, fix the caliper to the upright using two **IM** screws.

STEP 5

Now turn the assembly around and connect the right-side **brake line (40E)** to the **brake piston cover (44C)** in the same way as before, then position the **right brake caliper (44B)** over the **rear right upright (42A)**.

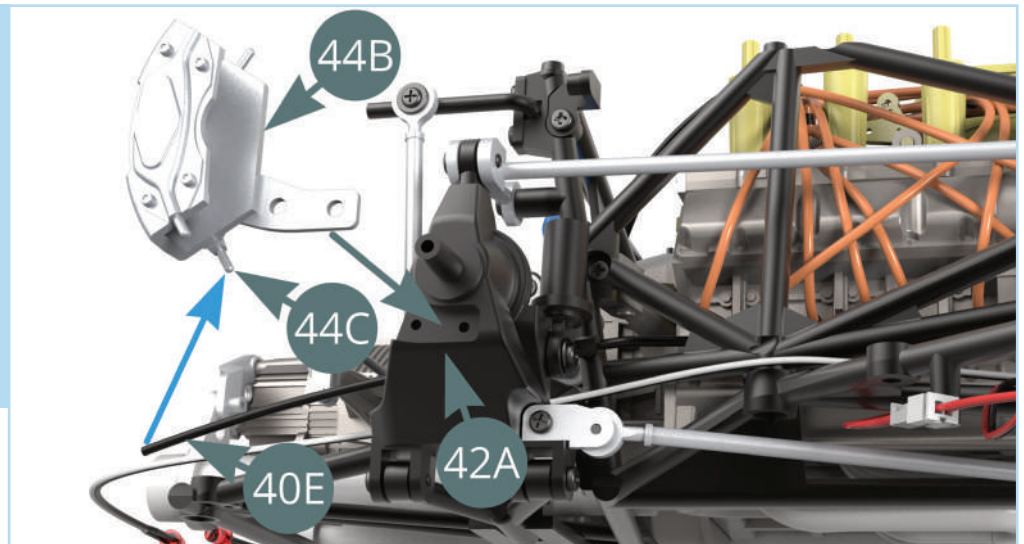

Fix the caliper in place using two **IM** screws.

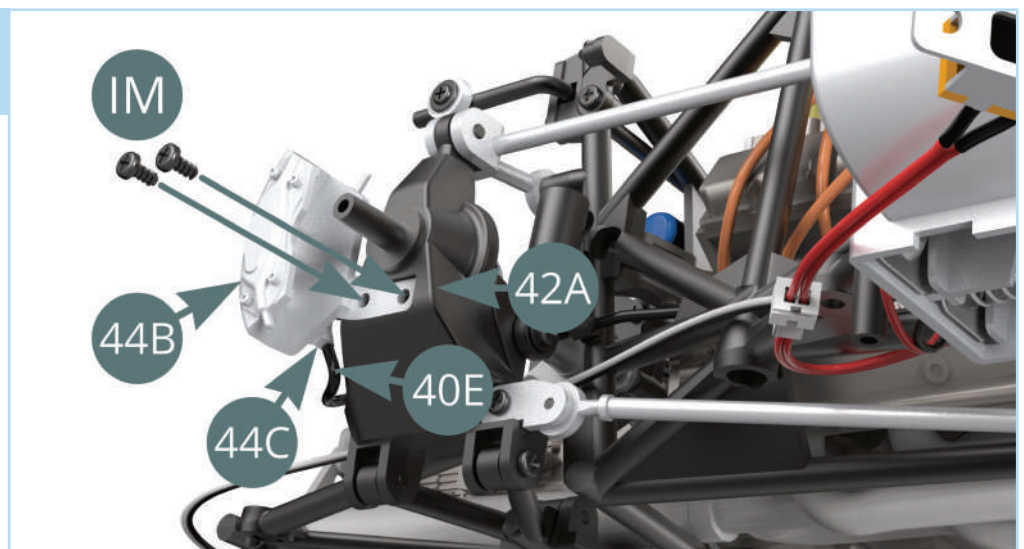

STAGE 44: BUILDING THE REAR BRAKE DISCS AND FITTING THE CALIPERS

STAGE COMPLETE

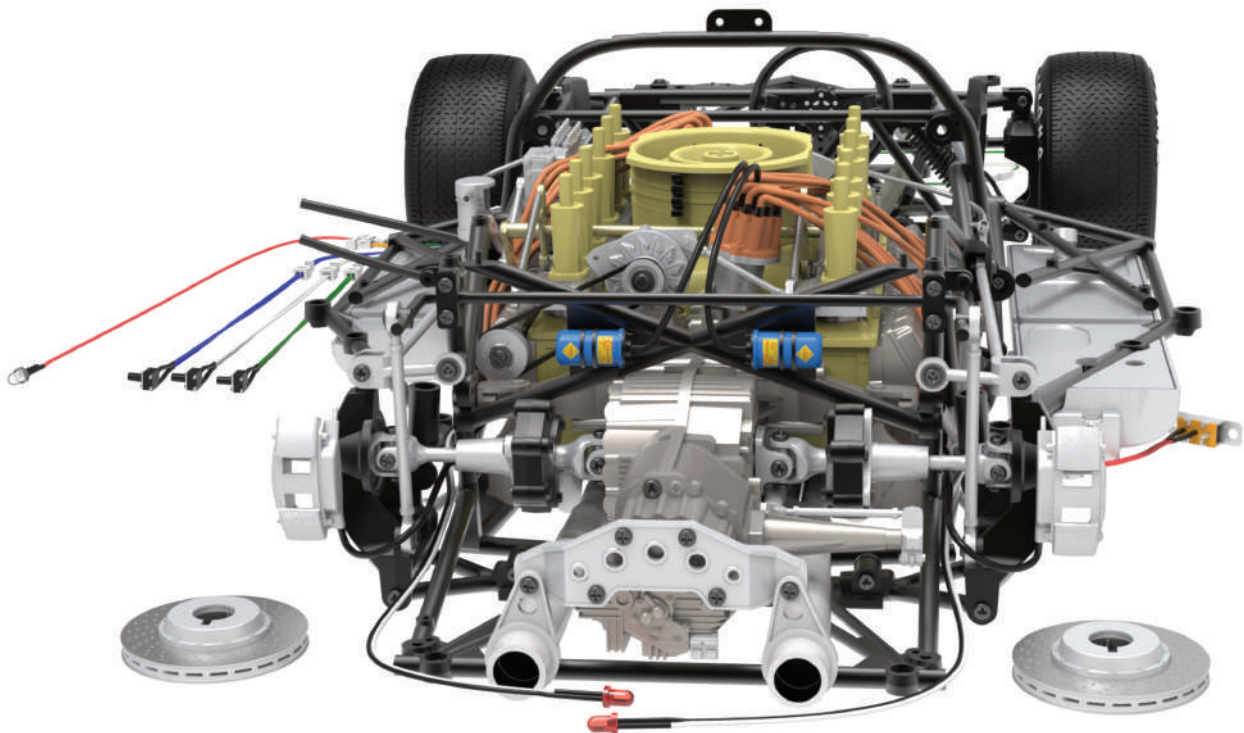
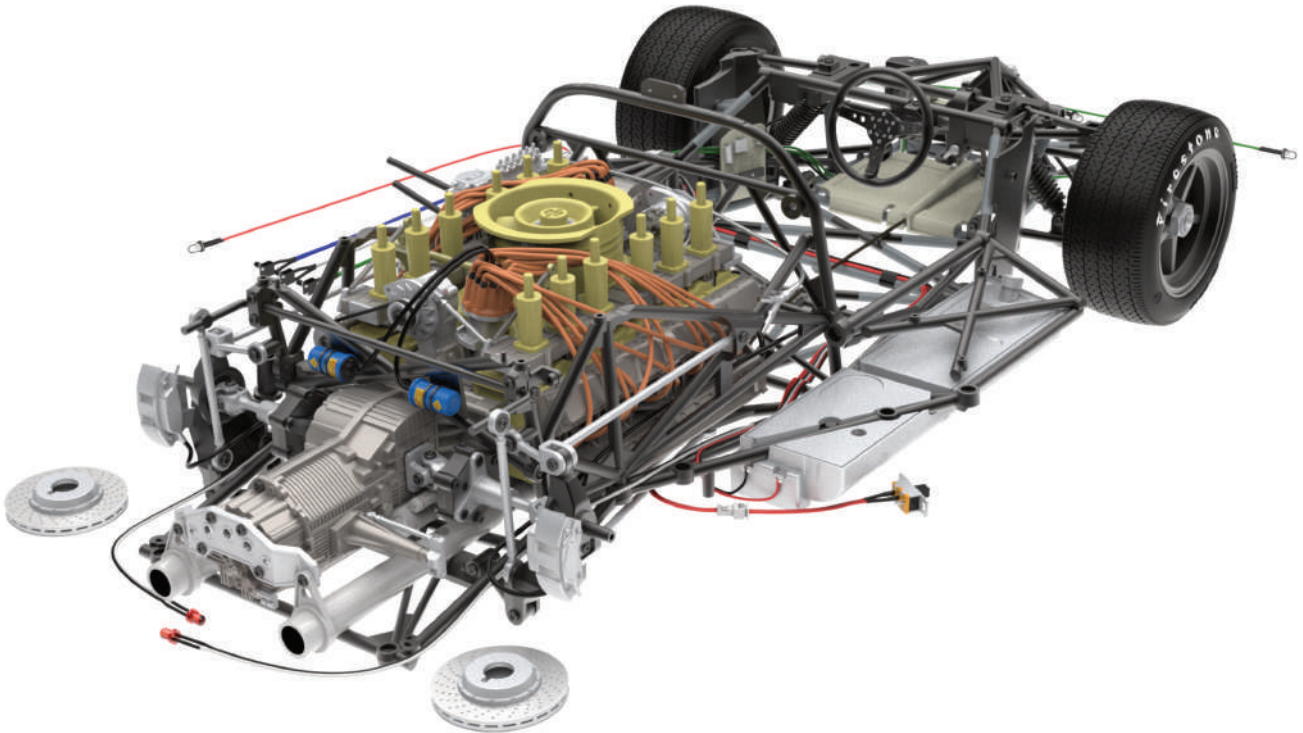

STAGE 45: ADDING THE REINFORCEMENT FRAME AND BUILDING THE LEFT TRANSMISSION LINE

45A Reinforcement frame

45B Left-hand stand

45C Right-hand stand

45D Transmission cooling line

45E Transmission cooling line

45F Pipe outlet

45G Support bracket

AP Screw 1.7 x 4 mm (x4)

IM Screw 1.7 x 3.5 mm (x3)

KM Screw 1.7 x 3 x 5 mm (x3)



ASSEMBLY DIAGRAM

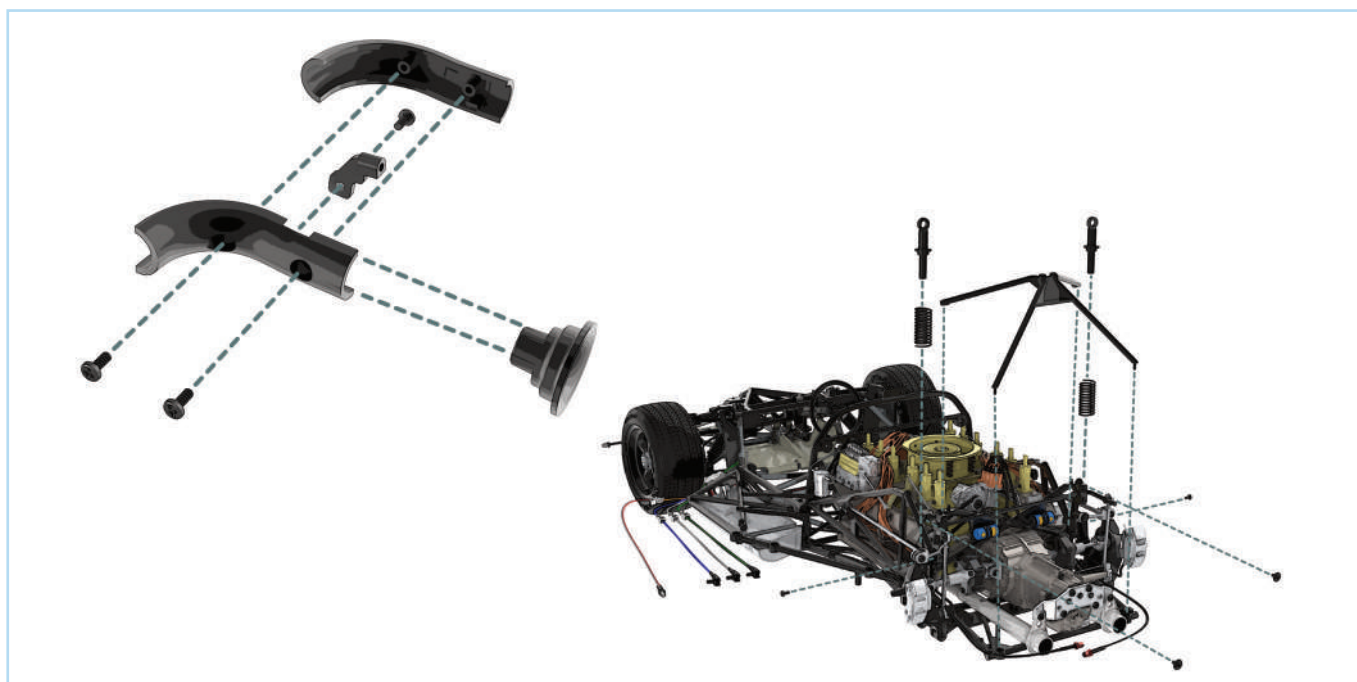

STAGE 45: ADDING THE REINFORCEMENT FRAME AND BUILDING THE LEFT TRANSMISSION LINE

STEP 1

Take the **support bracket (45G)** and align it with the **transmission cooling line (45E)** as shown. Fit the bracket in place then secure it using an **AP screw**.

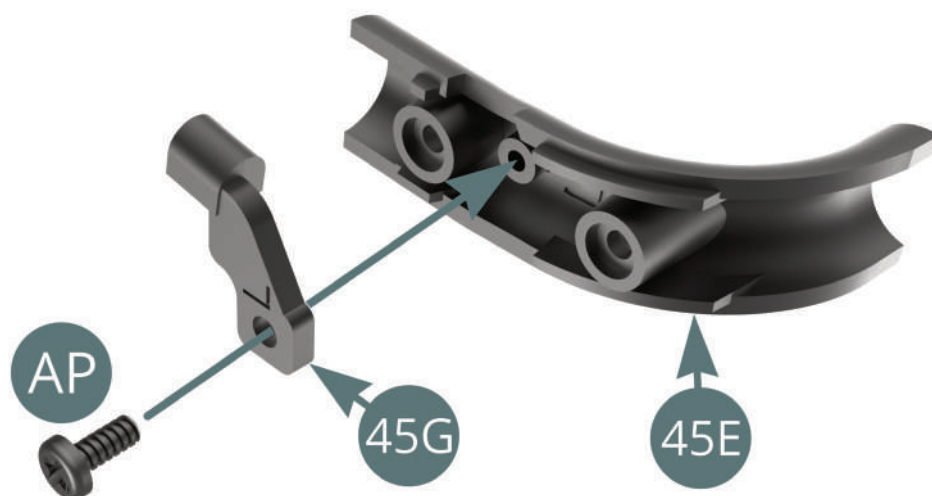

Fit the assembly onto the other half of the **transmission cooling line (45D)** as shown then secure together using two **AP screws**.

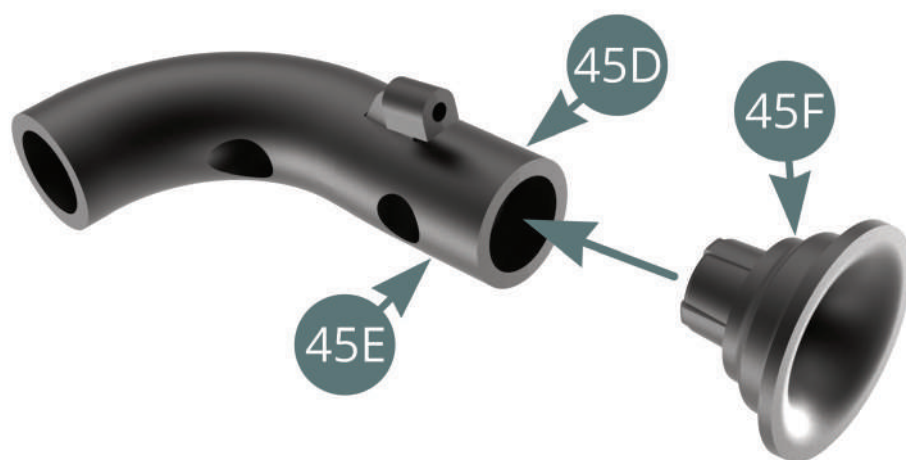

Press the **pipe outlet (45F)** into the end of the transmission line assembly as shown.

STAGE 45: ADDING THE REINFORCEMENT FRAME AND BUILDING THE LEFT TRANSMISSION LINE

STEP 2

Fit the **reinforcement frame (45A)** onto the **chassis (25A)** by pressing the pins into the innermost holes (orange arrow, inset). Then align the screw holes at the other ends of the reinforcement frame with the corresponding holes in the left and right side frames (**38A and 39A**) (circled).

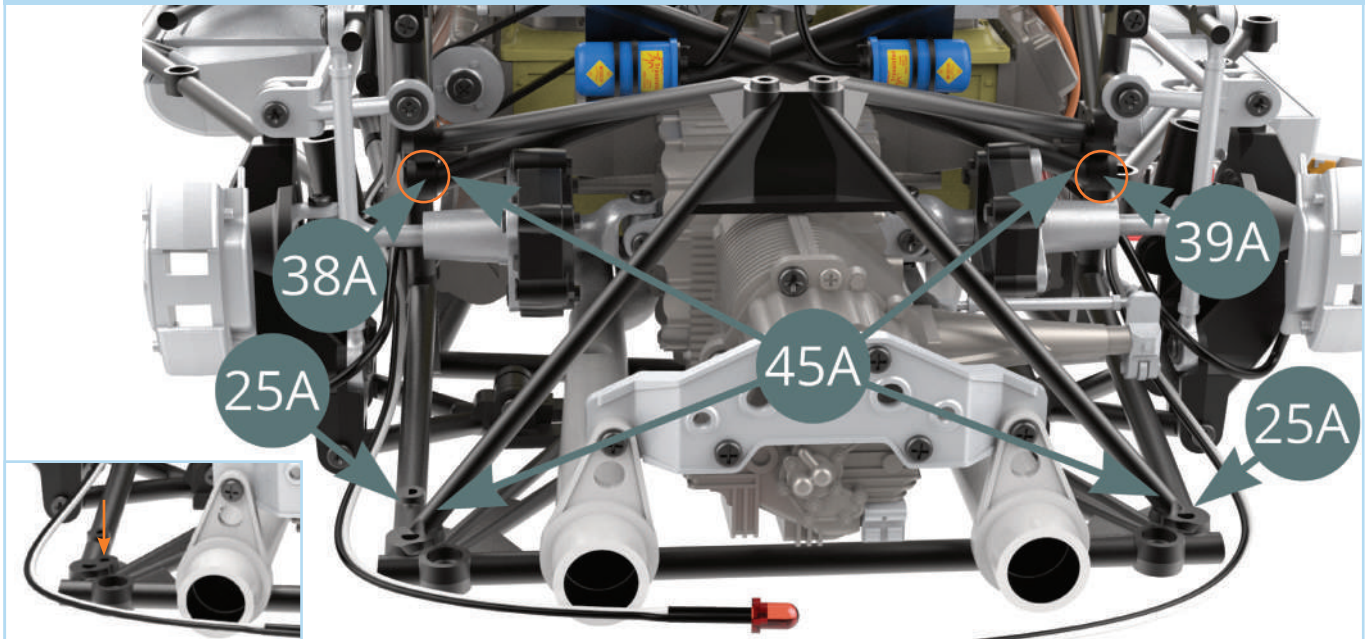

Locate the screw hole on the **right side frame (39A)** then drive an **IM** screw through it and into the reinforcement frame. We suggest partially tightening this screw then returning to tighten it fully once the screw for the left side frame is secure (see next step).

We recommend using the thin screwdriver from Stage 37. Pass it between the cylinder and rear upright (orange arrow).

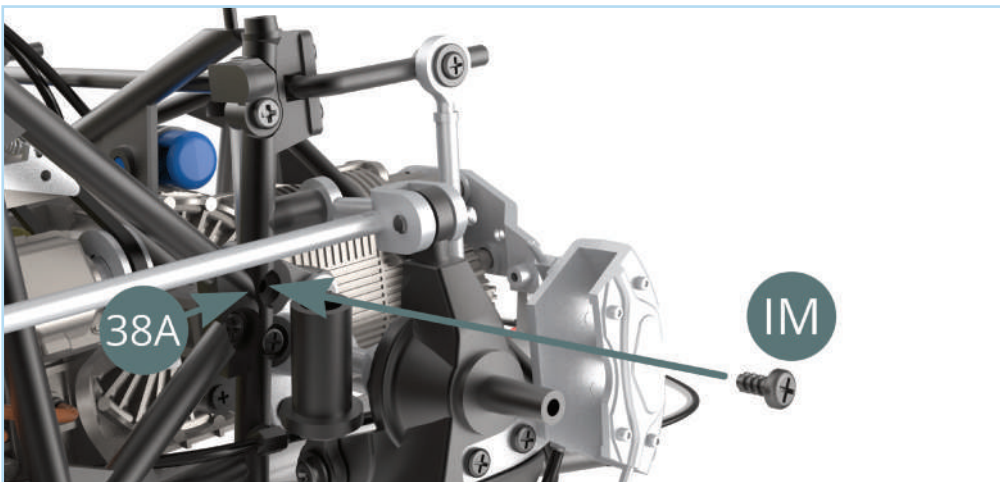
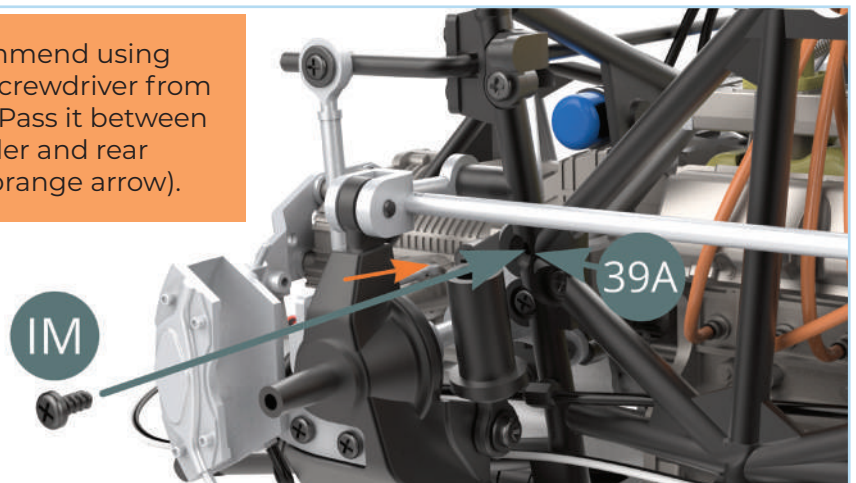

Take an **IM** screw and drive it through the **left side frame (38A)** and into the reinforcement frame in the same way.

STAGE 45: ADDING THE REINFORCEMENT FRAME AND BUILDING THE LEFT TRANSMISSION LINE

STEP 3

Retrieve the **shock absorber spring (41I)** and **shock absorber piston (41F)** supplied with Stage 41. Fit the spring onto the right hand **shock absorber cylinder (41H)** then push the piston inside.

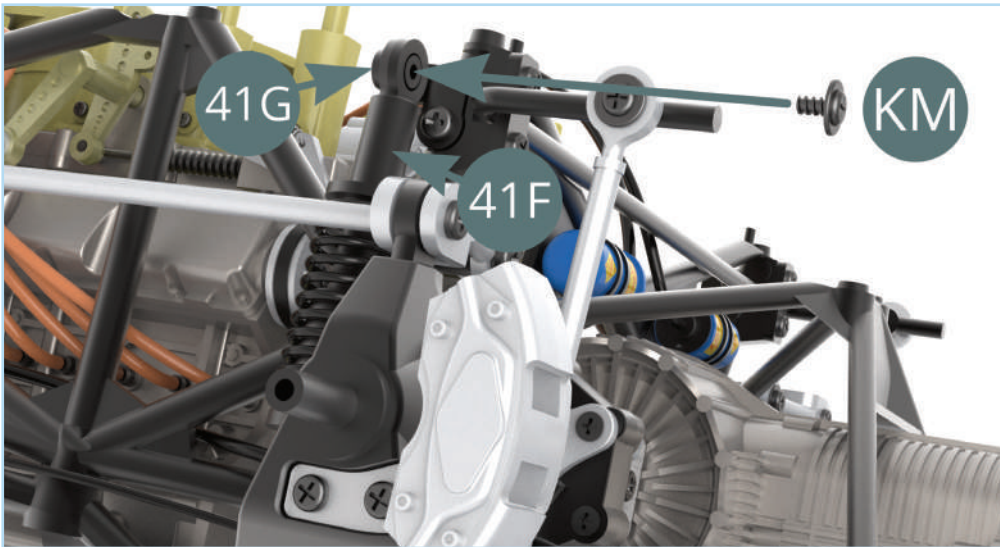
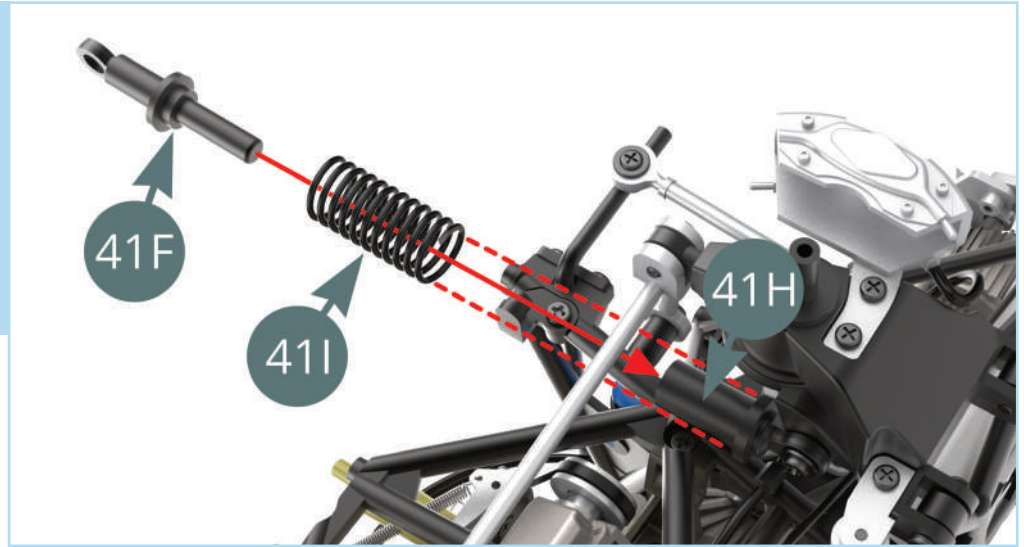

Press the **shock absorber piston (41F)** down and fit its eyelet over the **bracket (41G)**, then secure in place using a **KM** screw.

STEP 4

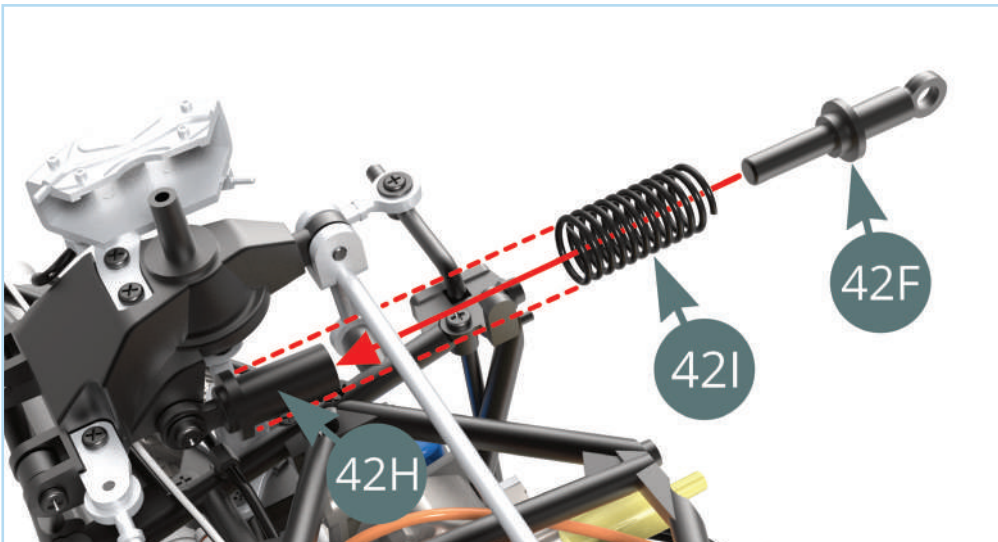

Take the piston and spring supplied with Stage 42 (**42F and 42I**) then fit them with the left hand **shock absorber cylinder (42H)** in the same manner as before.

STAGE 45: ADDING THE REINFORCEMENT FRAME AND BUILDING THE LEFT TRANSMISSION LINE

Press and fit the piston onto the **bracket (42G)** and fix using a **KM** screw.

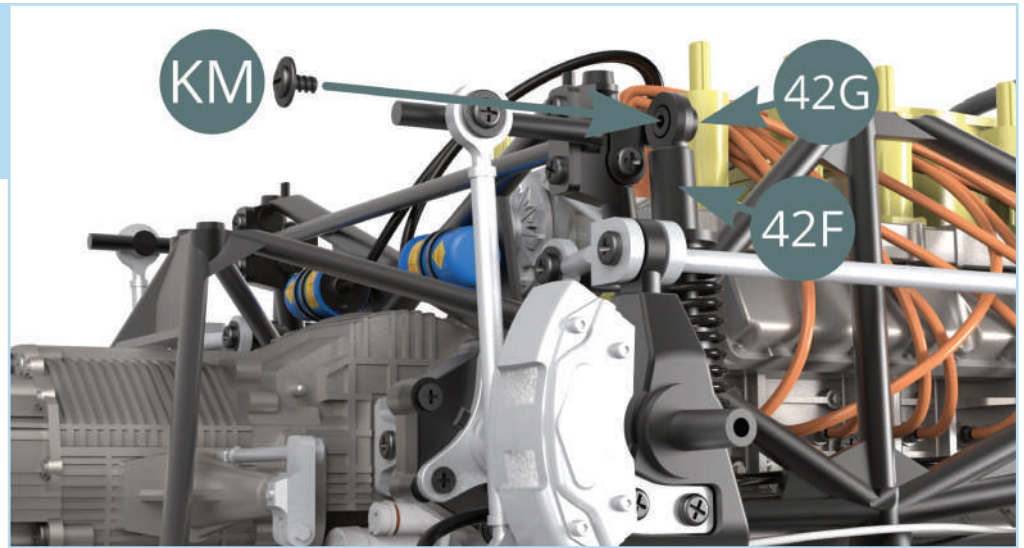

STAGE COMPLETE

