

STEVE MCQUEEN'S ICONIC **PORSCHE** **917KH**



Pack 10

BUILD INSTRUCTIONS

**STAGE 73: MOUNTING THE FUEL PUMP ON
THE RIGHT CHASSIS PLATE**

**STAGE 74: FITTING THE BATTERY ON THE
RIGHT CHASSIS PLATE**

**STAGE 75: ATTACHING THE FUEL FILLER NECK
AND THE SECOND FUEL PUMP**

**STAGE 76: FITTING THE RIGHT REAR
WHEEL ARCH**

**STAGE 77: ASSEMBLING AND INSTALLING
THE SPARE WHEEL**

**STAGE 78: INSTALLING THE FRONT BRAKE
COOLING PIPES**

**STAGE 79: FITTING THE FRONT WHEEL
ARCHES TO THE FRONT FLOOR PANEL**

STAGE 80: PREPARING THE FRONT BODY

Porsche, the Porsche shield and the distinctive design of Porsche cars are trademarks and trade dress of Porsche AG. Permission granted.

The Gulf trademarks are used under license from Gulf Oil International Ltd.

Personality rights of Steve McQueen are used with permission of Chadwick McQueen and The Terry McQueen Testamentary Trust.

Represented exclusively by Greenlight.

AGORA
MODELS

Advice from the experts

Spare screws are included with each part. Occasionally, you may be instructed to keep spare or unused screws for a later stage. Keep these spares in a safe place and label them correctly.

Please make sure you don't mix up the screws. They look quite similar, but the threads do vary slightly. Using the wrong screws may damage the parts.

When securing parts together using multiple screws, fit each screw loosely to ensure all the parts are correctly aligned before gently tightening them firmly, but not overtight, in the order in which you placed them.

The screwdriver can be magnetized by stroking it with a magnet (fridge magnet, etc.) enabling it to hold the screws and make assembly easier.

If a screw is tight going into a metal part, do not force it as you may shear the head off. Remove it and put a tiny smear of Vaseline, soap or light oil on the thread. That will lubricate it and make it easier to drive home.

During the course of this build, you will receive many pieces that you will assemble immediately – following the instructions in the corresponding stage – and other pieces that you should store safely to one side, for use in future assembly stages.

Left and Right! When building your Porsche 917KH, the left or right hand side refers to each side as you are sitting in the car.



WARNING: Some parts are assembled using magnets. These magnets can cause serious injury if they are swallowed. Keep away from children. If you suspect a magnet has been swallowed, seek medical help straight away.

STAGE 73: MOUNTING THE FUEL PUMP ON THE RIGHT CHASSIS PLATE

73A Right chassis plate

73B Fuel pump

73C Protective shield

73D Pump fitting

73E Connector

73F Braided fuel line

73G Fuel line

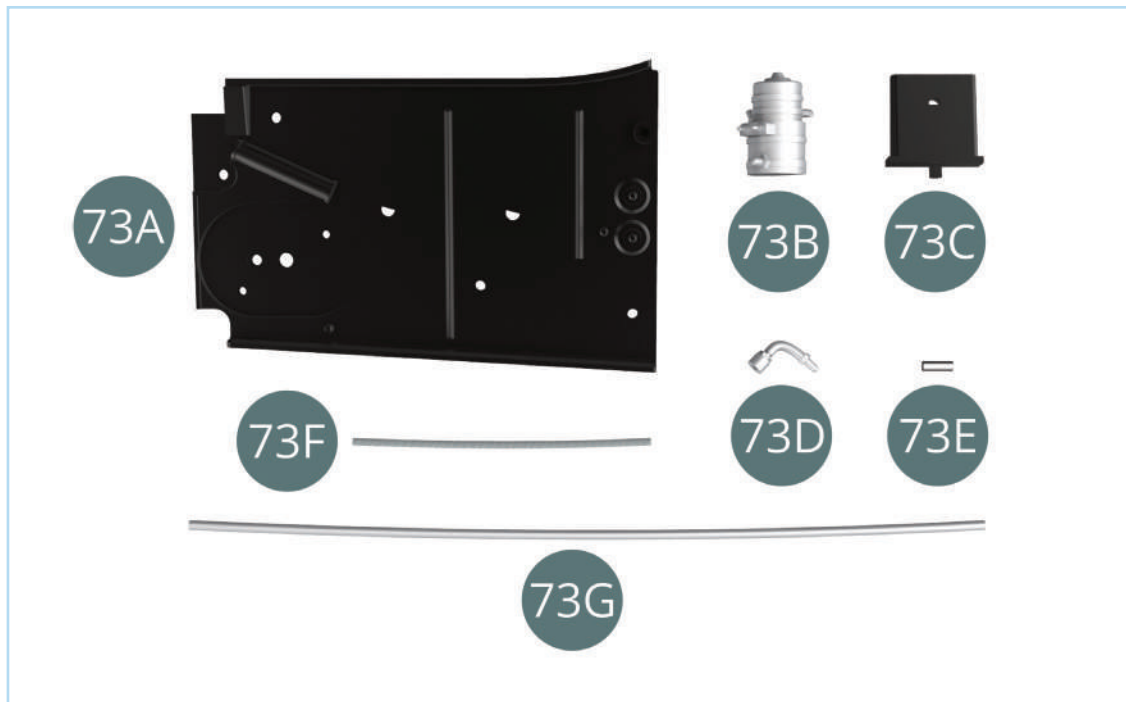

ASSEMBLY DIAGRAM

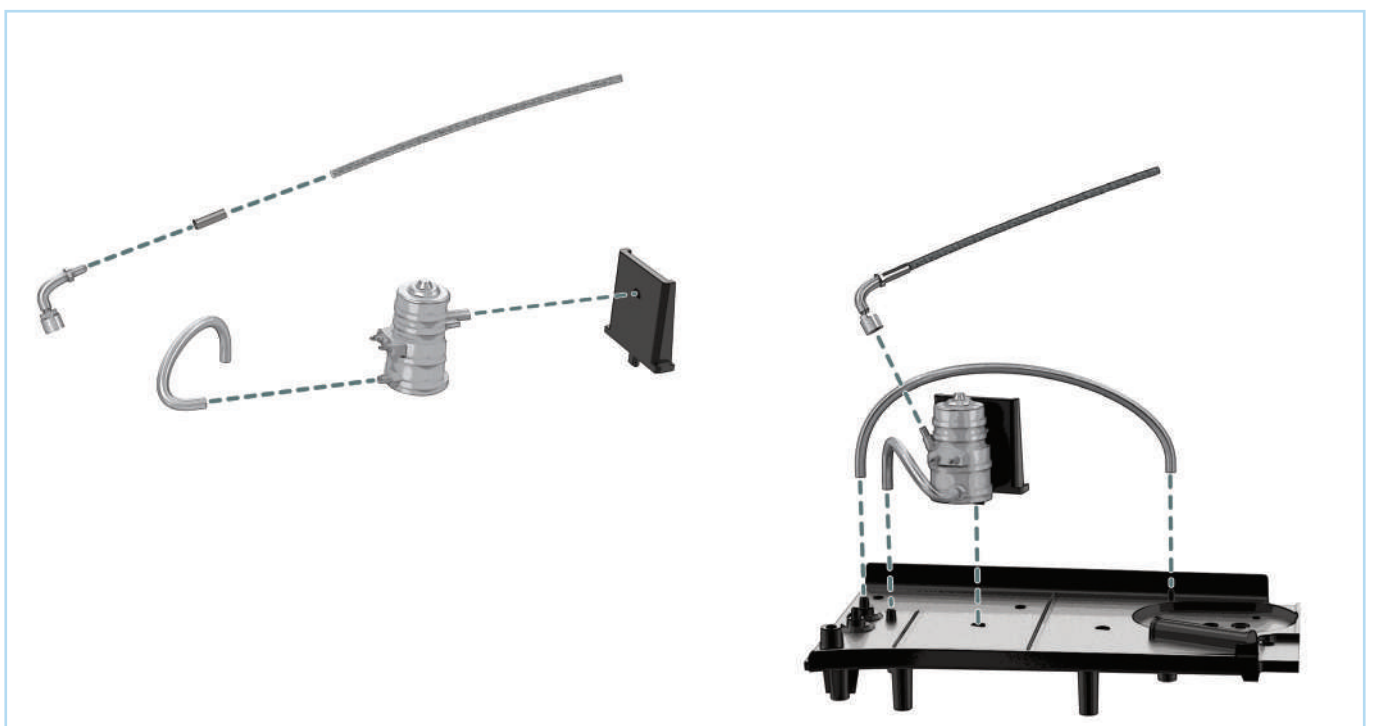

STAGE 73: MOUNTING THE FUEL PUMP ON THE RIGHT CHASSIS PLATE

STEP 1

Take the **fuel line (73G)** and cut two sections from it: one measuring 50 mm in length (**73G-1**) and the other measuring 90 mm (**73G-2**).

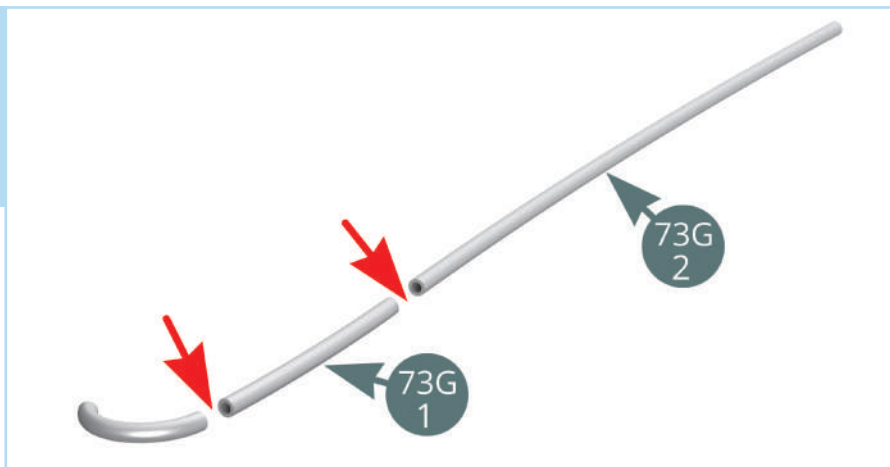

Take the longer **fuel line (73G-2)** and fit the ends onto the indicated pins of the **right chassis plate (73A)**.

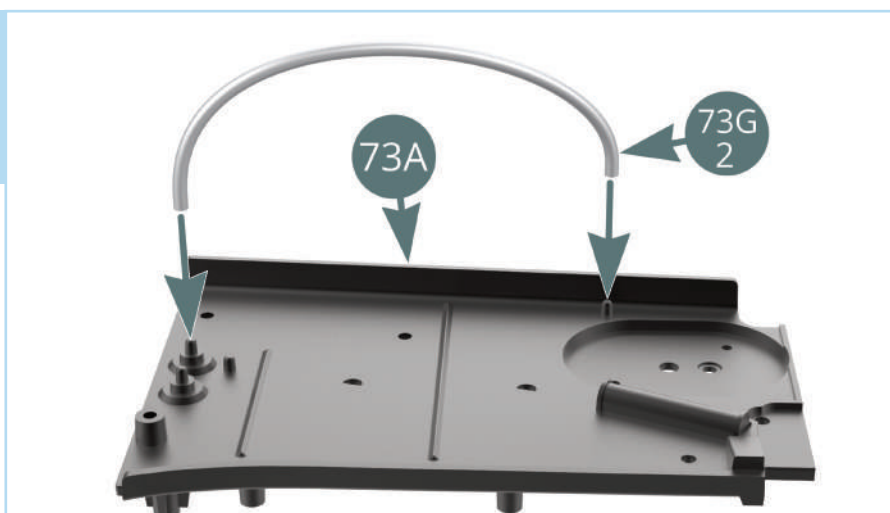

STEP 2

Press the **fuel pump (73B)** into the D-shaped hole of the **protective shield (73C)**. Bend and then connect one end of the shorter **fuel line (73G-1)** onto the pin at the bottom of the fuel pump.

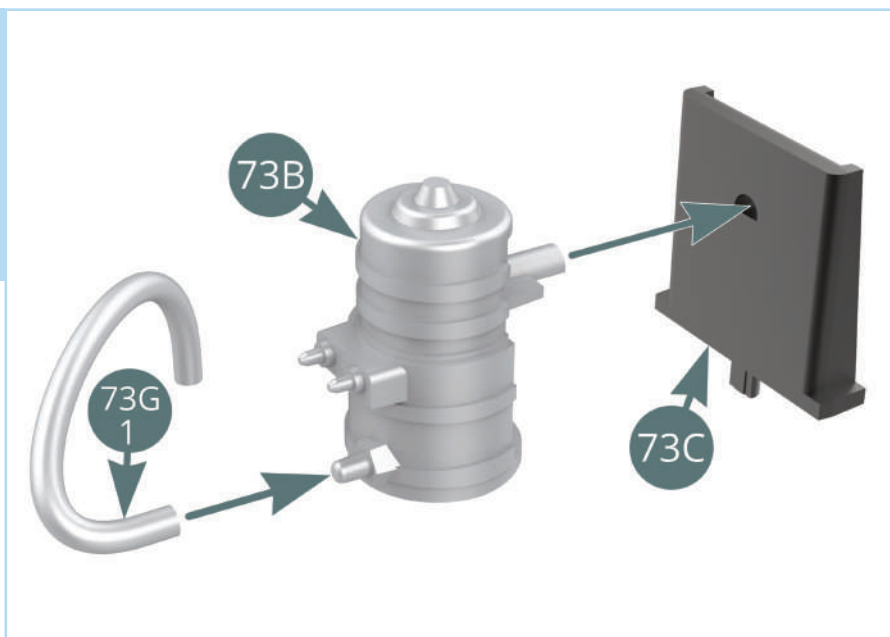

STAGE 73: MOUNTING THE FUEL PUMP ON THE RIGHT CHASSIS PLATE

Fit the **protective shield (73C)** onto the **right chassis plate (73A)** by pressing it into the D-shaped hole, then connect the loose end of the shorter **fuel line (73G-1)** onto the protruding pin of the plate.

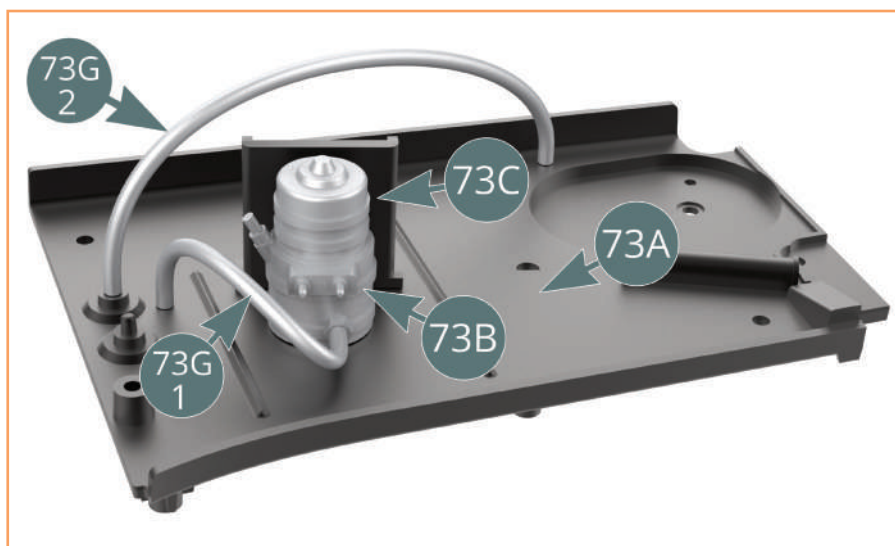
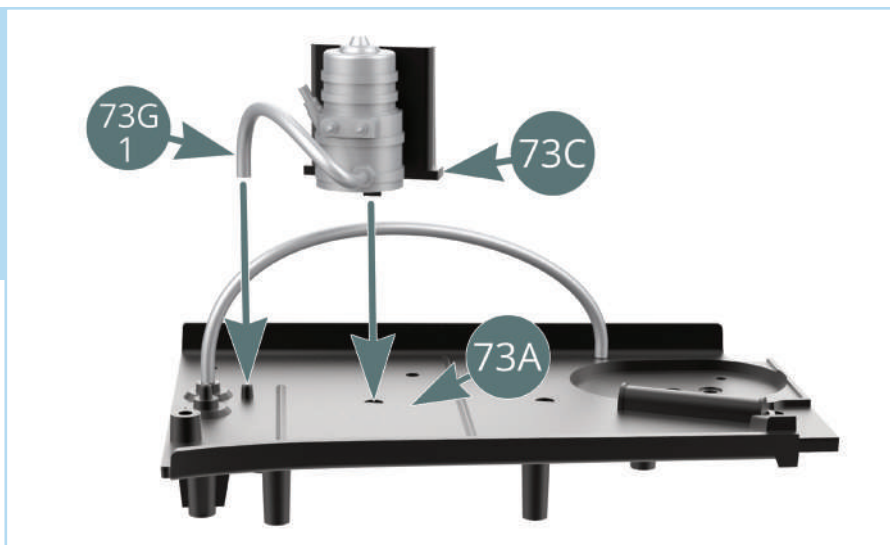

The right chassis plate should look like this with the fuel pump and fuel lines installed.

STEP 3

Fit one end of the **braided fuel line (73F)** into the **connector (73E)**, then press the connector onto the pin of the **pump fitting (73D)**.

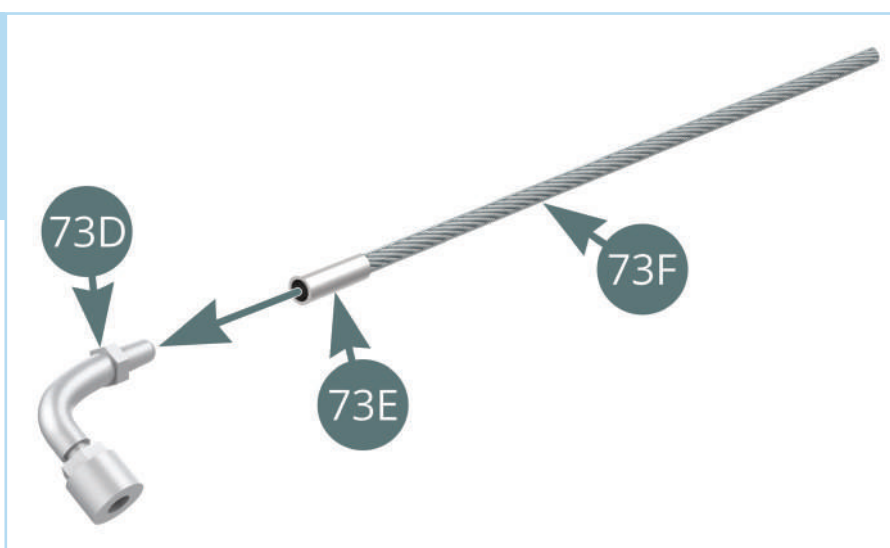

STAGE 73: MOUNTING THE FUEL PUMP ON THE RIGHT CHASSIS PLATE

STEP 4

Fit the **pump fitting (73D)** onto the pin of the **fuel pump (73B)** as shown.



STAGE COMPLETE

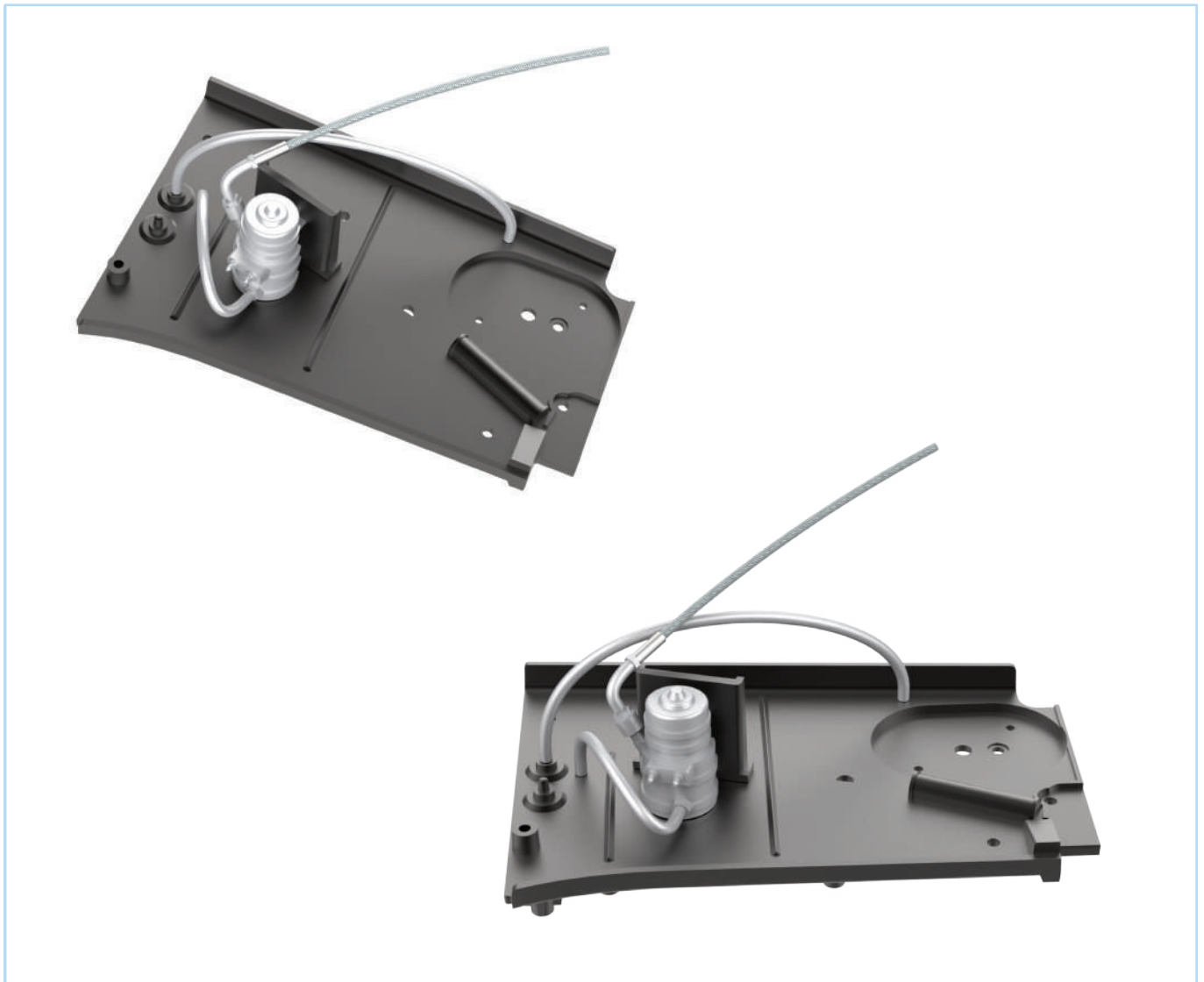

STAGE 74: FITTING THE BATTERY ON THE RIGHT CHASSIS PLATE

74A Battery

74B Battery holder

74C Battery cover

74D Battery terminal (x2)

74E Support rod

74F Protective shield

LP Screws 1.2 x 3.5 mm (x3)

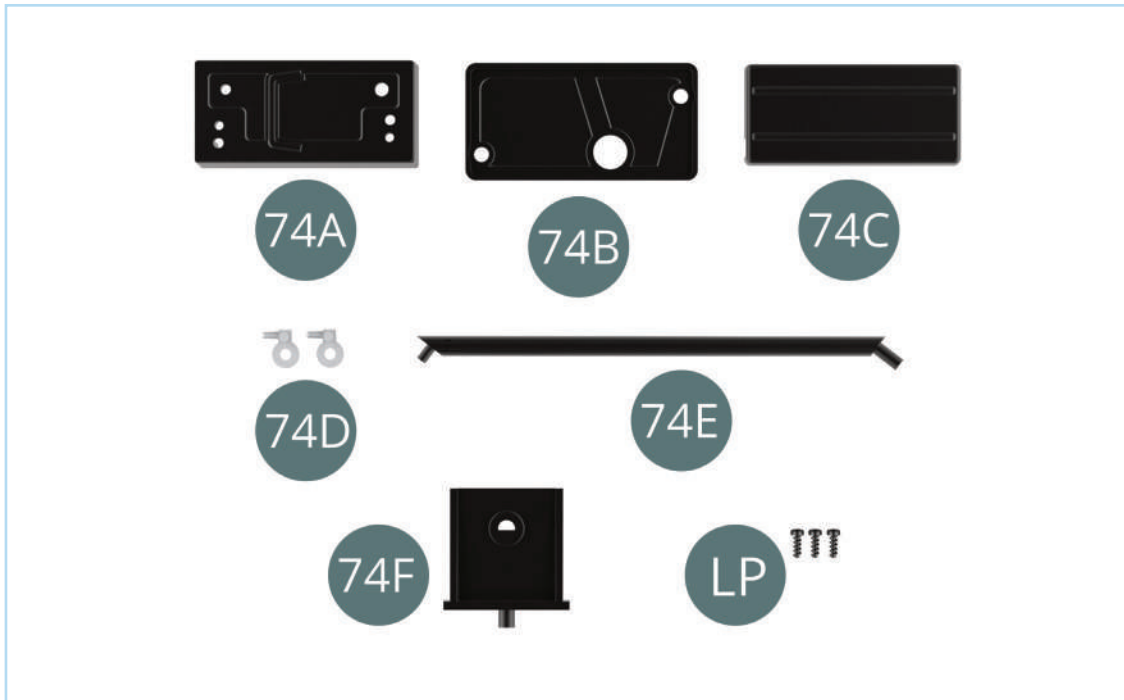

ASSEMBLY DIAGRAM



STAGE 74: FITTING THE BATTERY ON THE RIGHT CHASSIS PLATE

STEP 1

Position the two **battery terminals (74D)** onto the top of the **battery (74A)** and secure them in place with two **LP screws**. Once the terminals are secure, fit the **battery cover (74C)** on top by pressing the two pins of the cover into the holes of the battery.

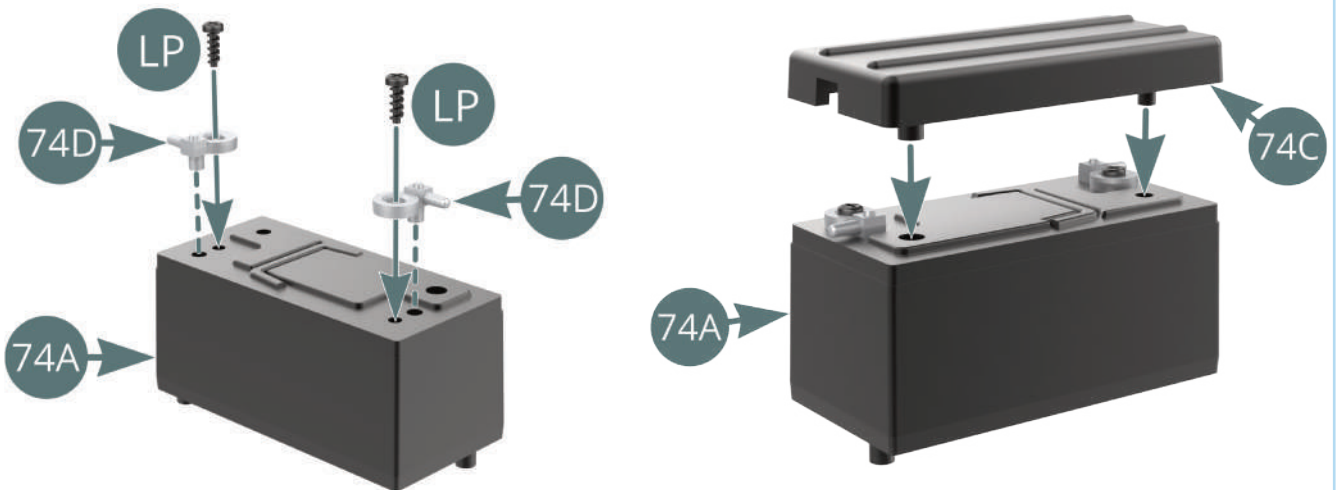

STEP 2

Press the **battery holder (74B)** into the holes of the **right chassis plate (73A)**, located behind the fuel pump shield. Then fit the pins of the **battery (74A)** into the holes of the holder as shown.

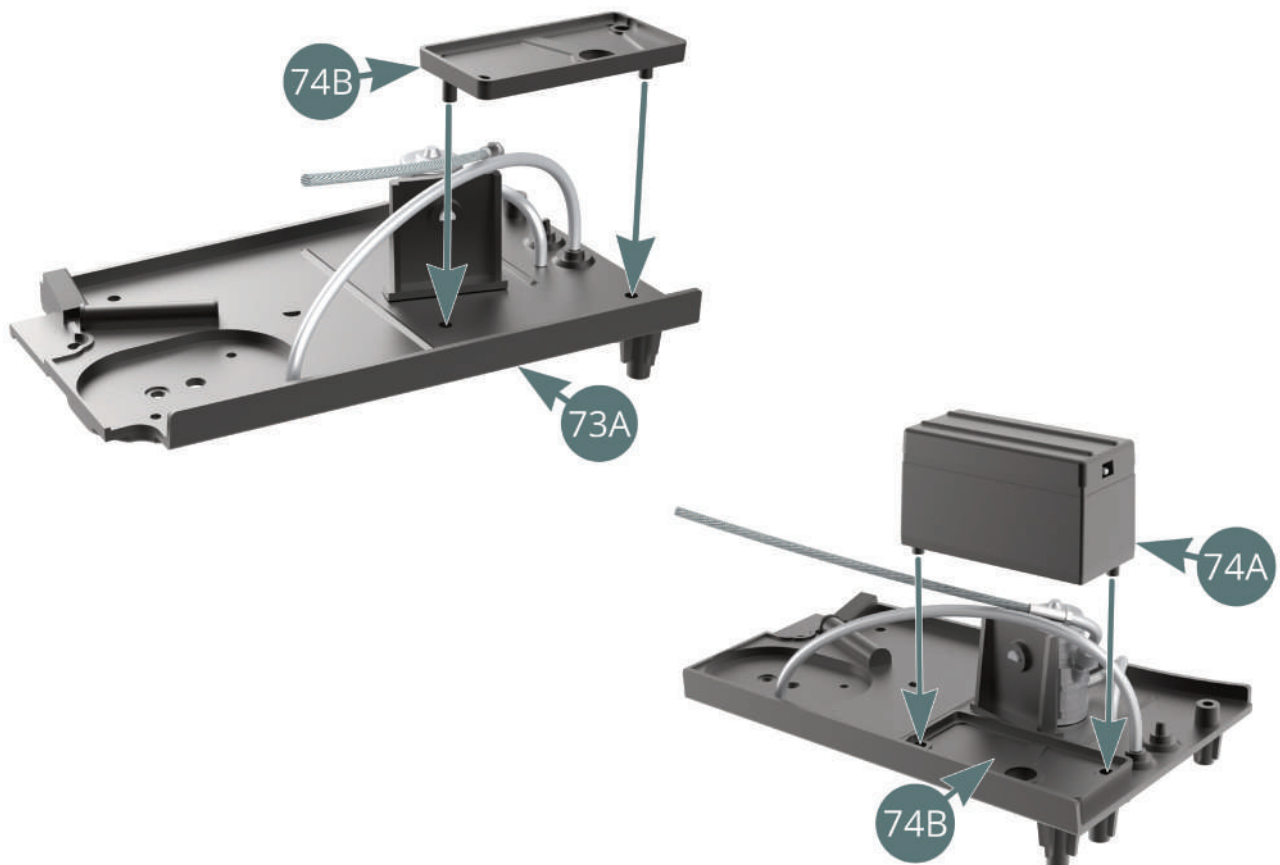

STAGE 74: FITTING THE BATTERY ON THE CHASSIS PLATE

STAGE COMPLETE

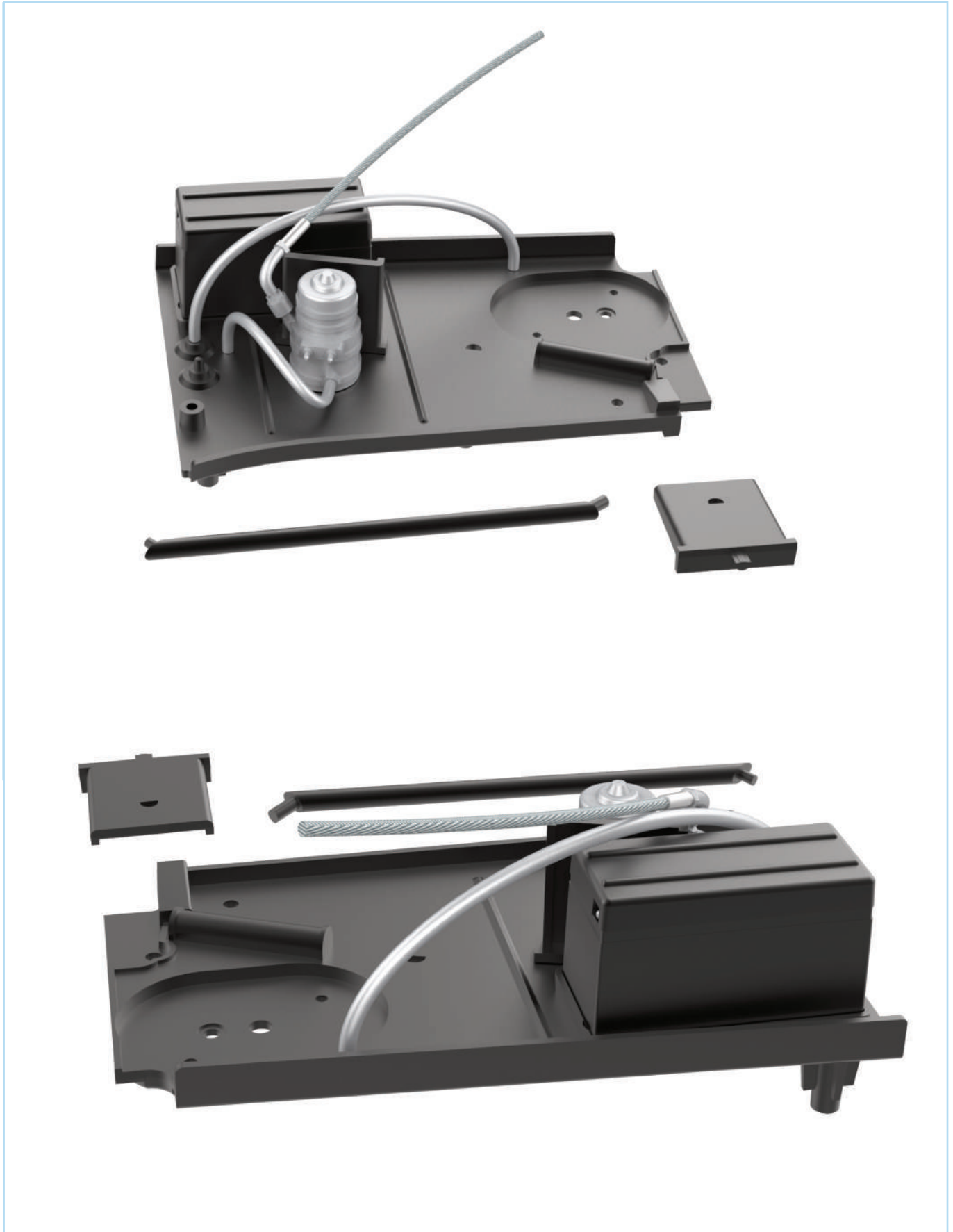

STAGE 75: ATTACHING THE FUEL FILLER NECK AND THE SECOND FUEL PUMP

75A Fuel filler neck

75B Fuel filler neck

75C Fuel filler cap

75D Handle

75E Tray

75F Breather pipe

75G Breather pipe

75H Fuel pump

75I Connector (x3)

75J Fuel pump fitting

75K Fuel line

75L Braided fuel line

BM Screws 2.0 x 4 mm (x3)

AP Screws 1.7 x 4 mm (x4)

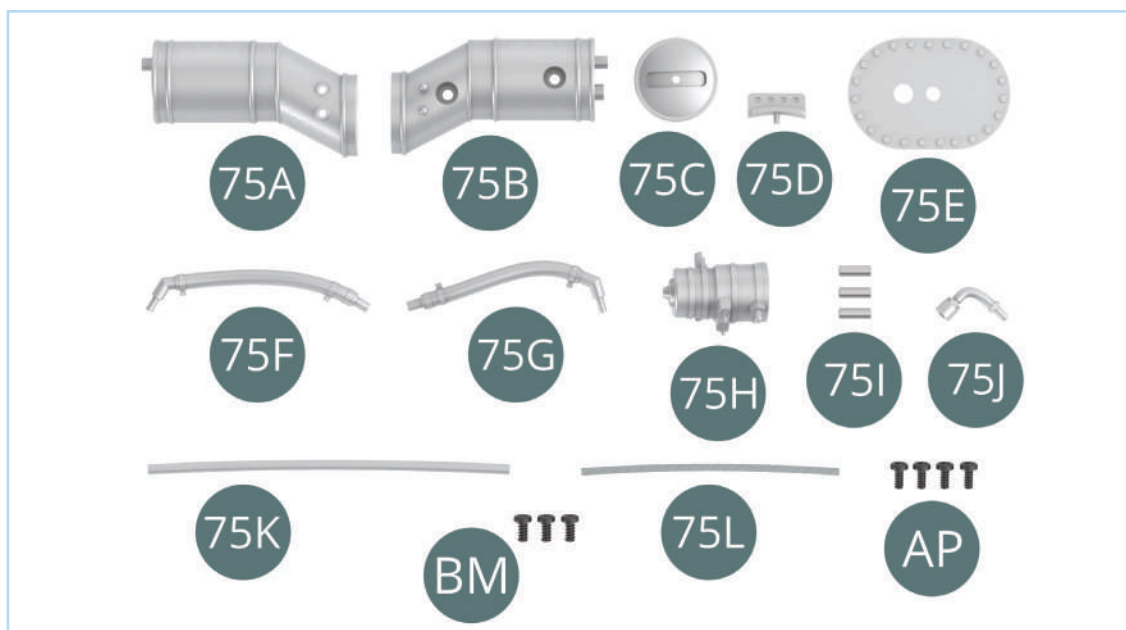

ASSEMBLY DIAGRAM

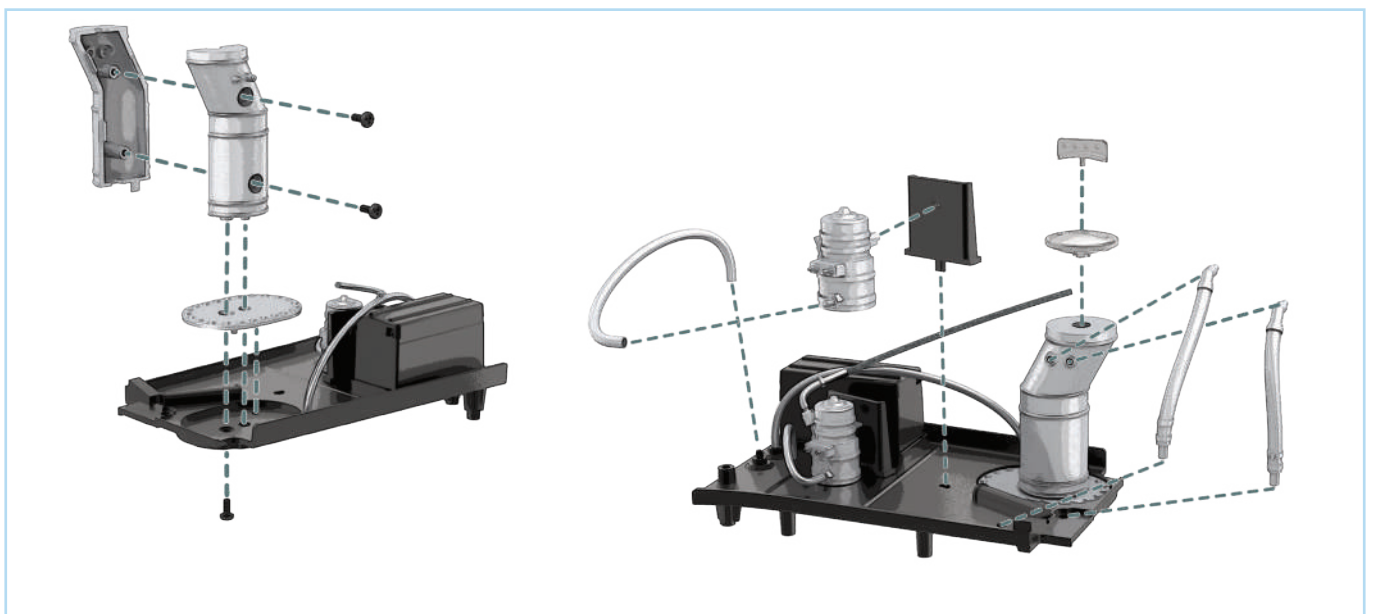

STAGE 75: ATTACHING THE FUEL FILLER NECK AND THE SECOND FUEL PUMP

ASSEMBLY DIAGRAM

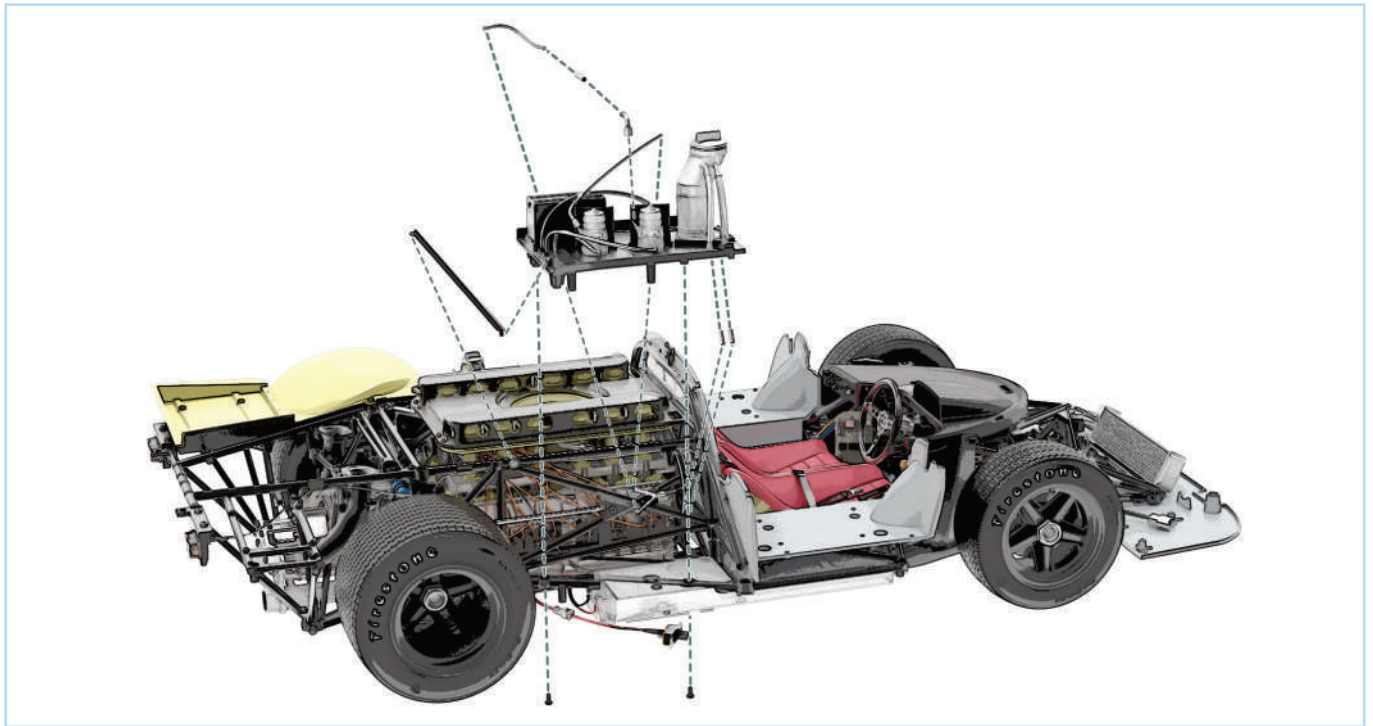

STEP 1

Fit the two halves of the **fuel filler neck (75A and 75B)** together and secure them using two **AP** screws. Fit them onto the **tray (75E)** and position onto the **right chassis plate (73A)** as shown. Secure the fuel filler neck and the tray to the plate using an **AP** screw.

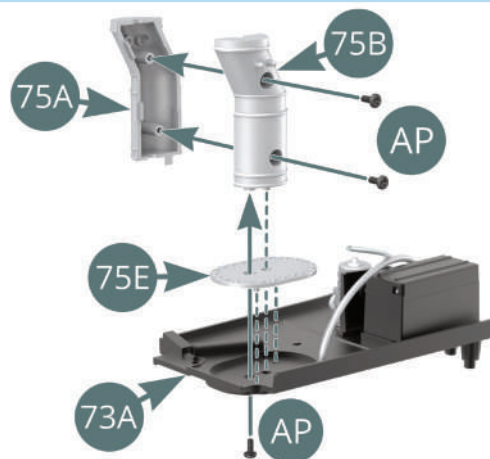

Connect the **breather pipes (75F and 75G)** to the **fuel filler neck (75A)** and the **right chassis plate (73A)** as shown.

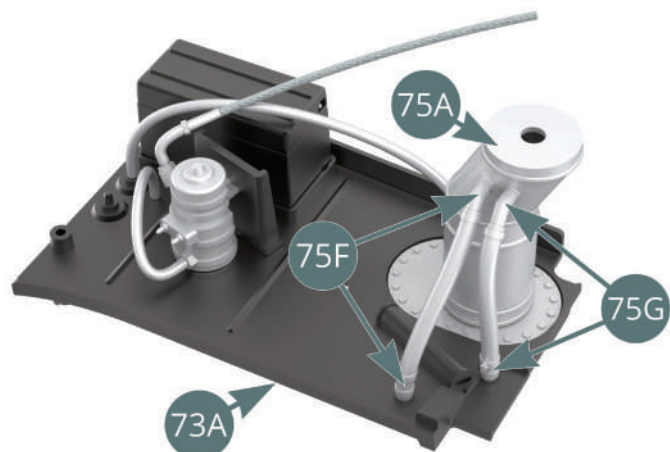

STAGE 75: ATTACHING THE FUEL FILLER NECK AND THE SECOND FUEL PUMP

STEP 2

Push the **handle (75D)** into the **fuel filler cap (75C)**, then press the cap into the top of the **fuel filler neck (75A)**. Fit the **fuel pump (75H)** into the shaped hole of the **protective shield (74F)** and position it on the **right chassis plate (73A)**. Once in place, take the **fuel line (75K)** and connect it to the pins of the fuel pump and plate as shown.

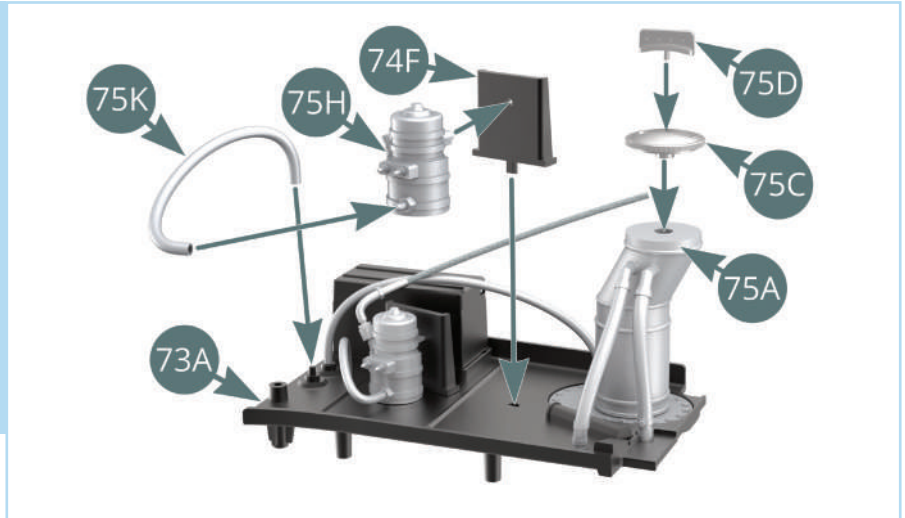

Once assembled, position the **right chassis plate (73A)** onto the crossbar of the **chassis (25A)** and the **right fuel tank top (33A)**.

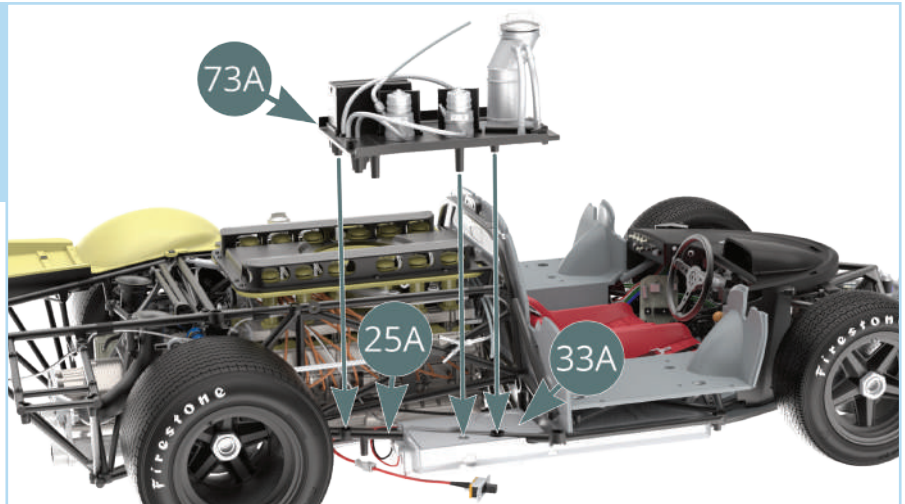

STEP 3

Carefully turn the assembly over while holding the plate in place, then secure together by driving two **BM** screws through the **chassis (25A)** and **right fuel tank top (33A)** into the **right chassis plate (73A)**.

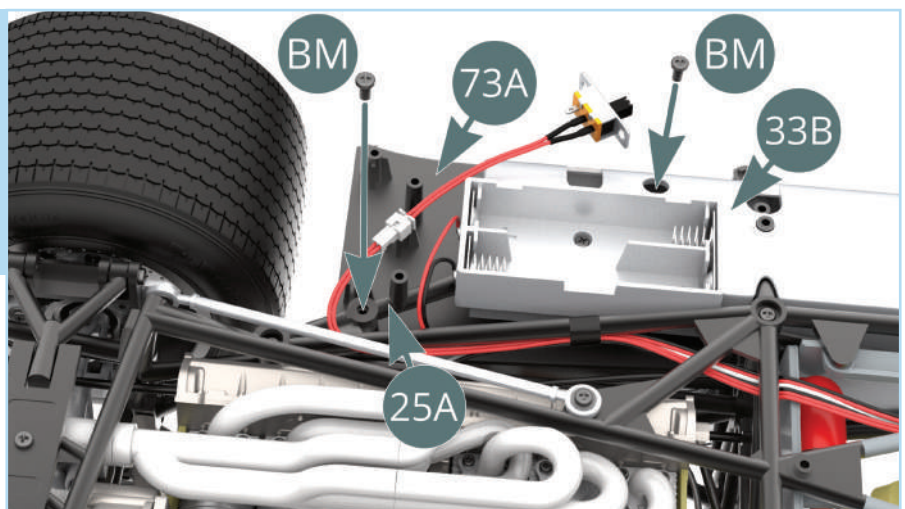

STAGE 75: ATTACHING THE FUEL FILLER NECK AND THE SECOND FUEL PUMP

Turn the assembly back over and locate the two **shielded fuel lines (70G)** running through from the left chassis plate. Fit the **connectors (75I)** onto the ends of the two fuel lines as shown.

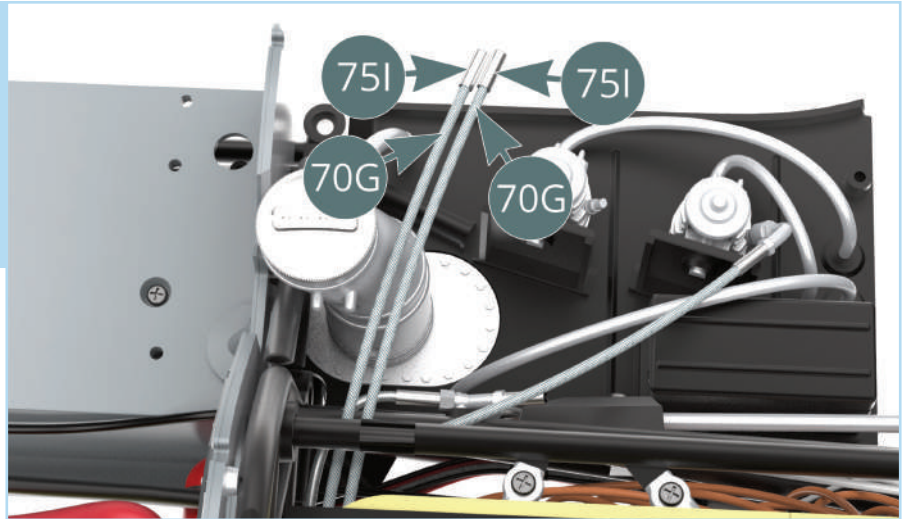

STEP 4

Bend the **shielded fuel lines (70G)** and fit the **connectors (75I)** onto the pins of the **fuel filler neck (75B)**.

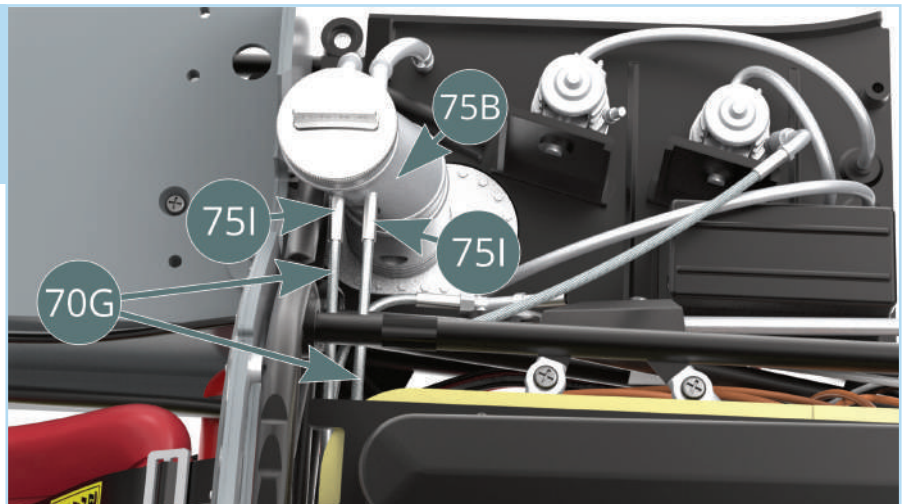

Now take the **braided fuel line (75L)** and fit one end into the remaining **connector (75I)**, then press the connector into the **fuel pump fitting (75J)**.

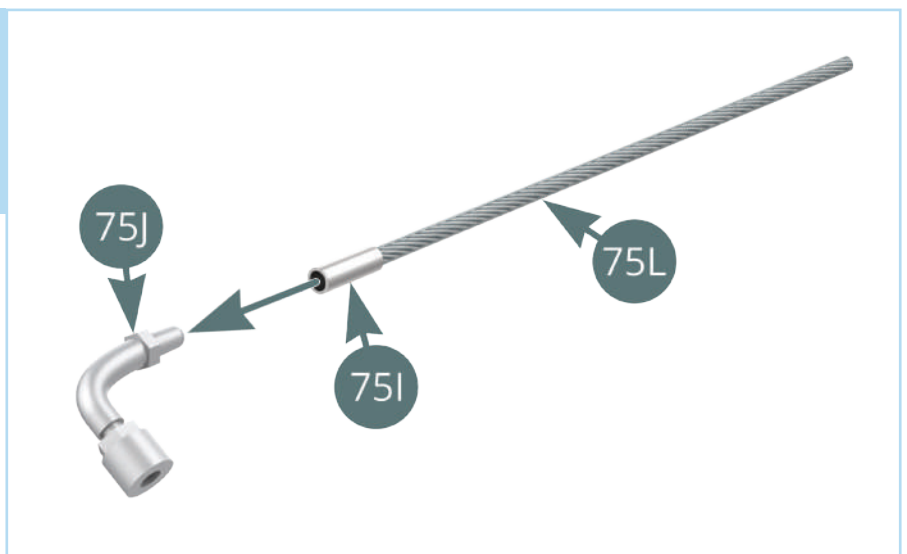

STAGE 75: ATTACHING THE FUEL FILLER NECK AND THE SECOND FUEL PUMP

STEP 5

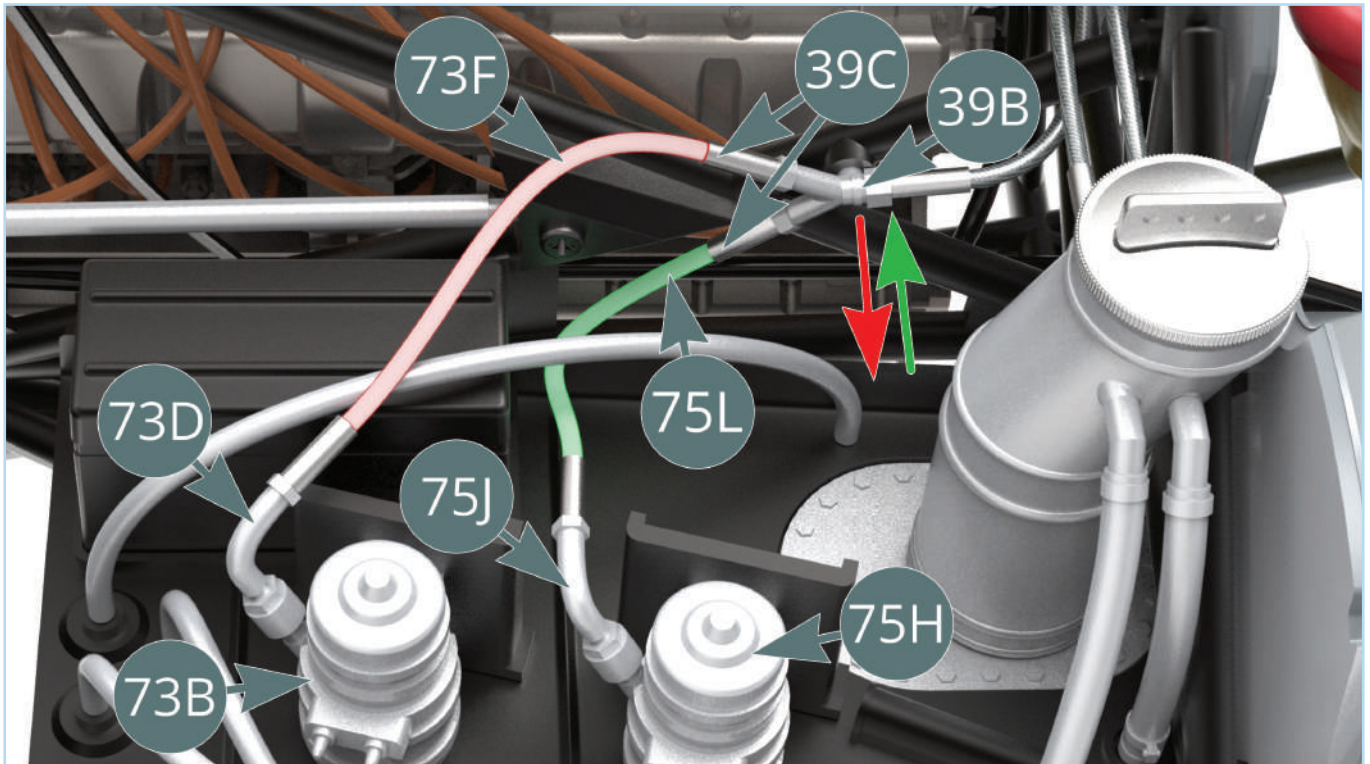

Detach the **Y branch (39B)** from the **right side frame (39A)** to help with fitting the lines, as shown by the red arrow. Fit the **braided fuel line (75L)**, highlighted in green, into the bottom connection of the branch and bend it into shape as shown, then attach the **fuel pump fitting (75J)** onto the pin of the **fuel pump (75H)**. Take the end of the other **braided fuel line (73F)**, highlighted in red, and bend it into shape to fit into the top of the branch. Once the lines are in place, reattach the **Y branch (39B)** – take care when refitting the branch, as you may need to bend the lines further.

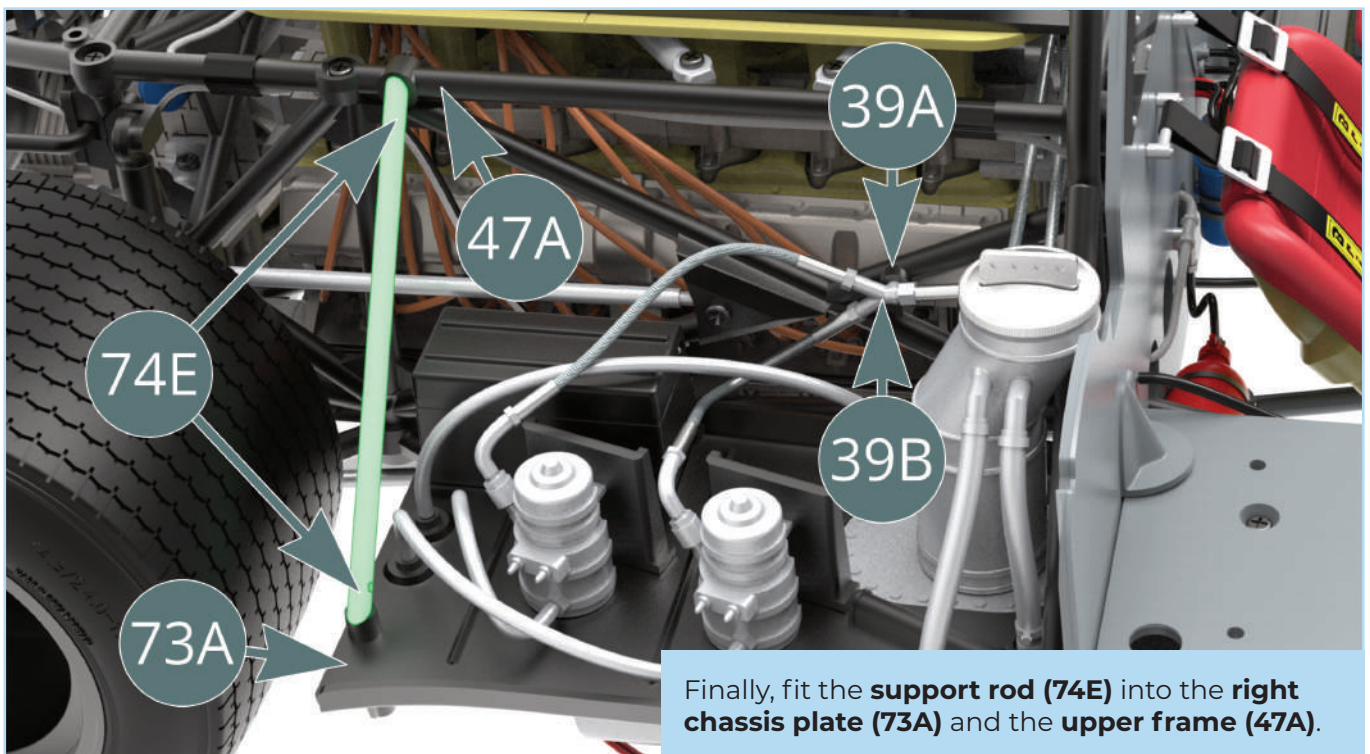

Finally, fit the **support rod (74E)** into the **right chassis plate (73A)** and the **upper frame (47A)**.

STAGE 75: ATTACHING THE FUEL FILLER NECK AND THE SECOND FUEL PUMP

STAGE COMPLETE

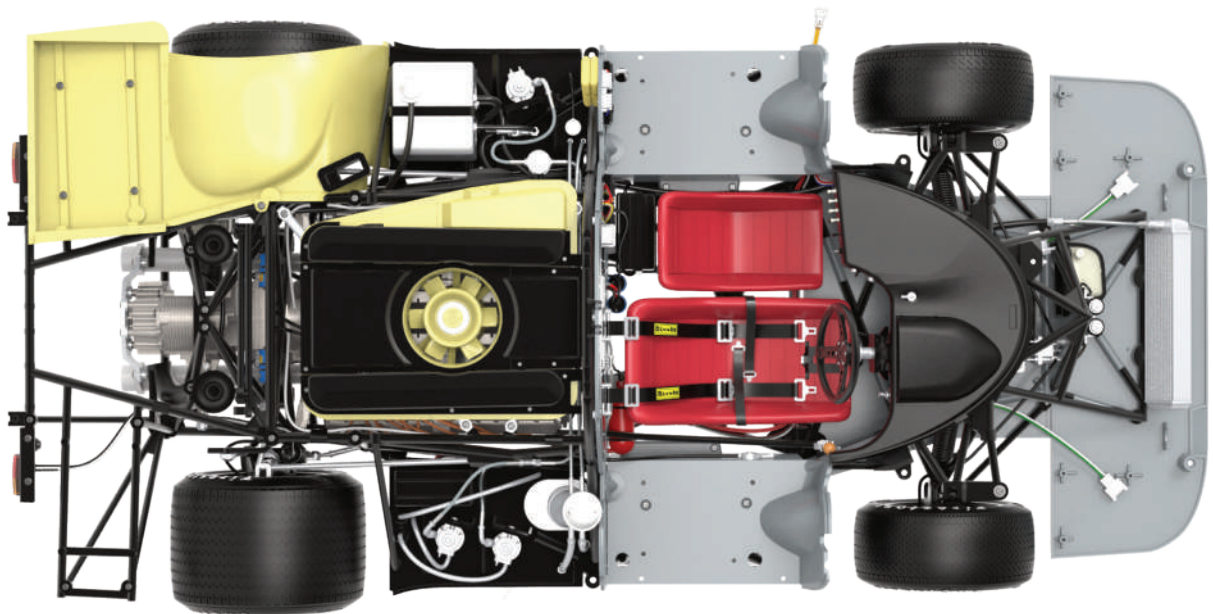
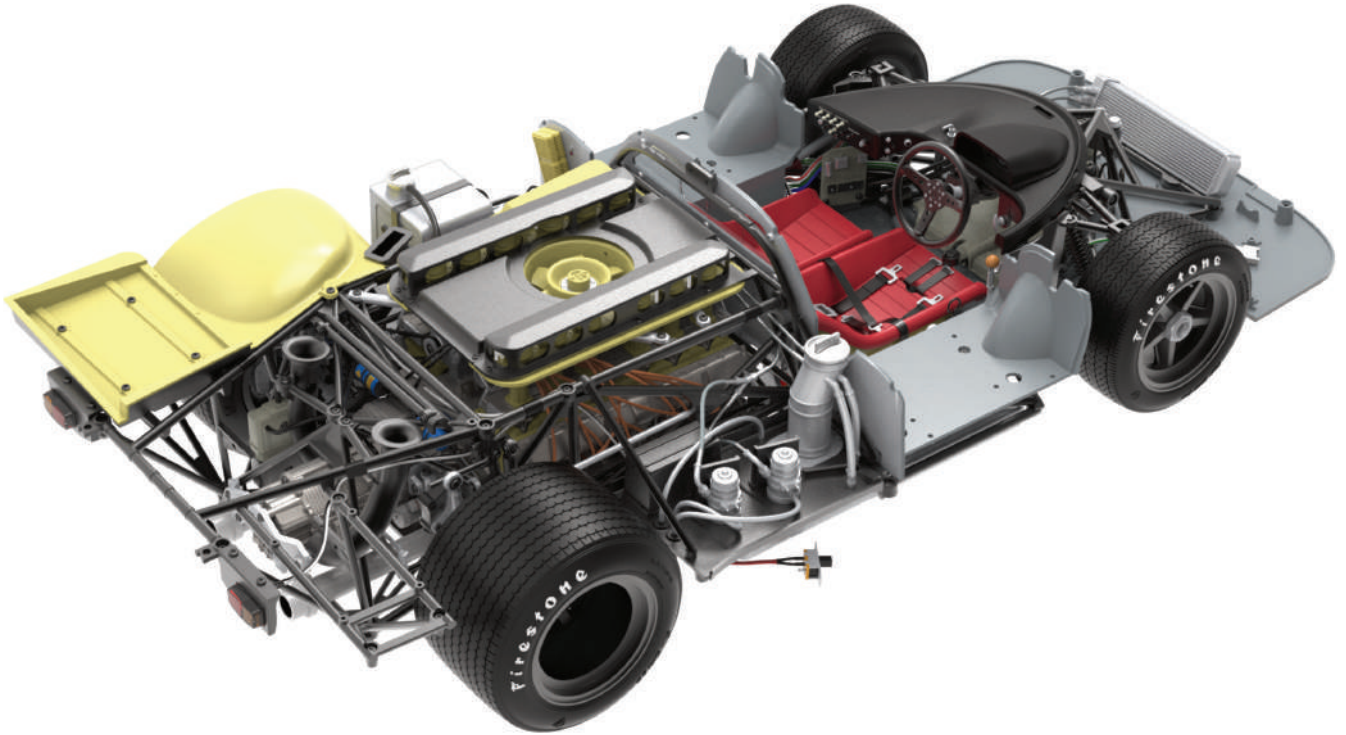

STAGE 76: FITTING THE RIGHT REAR WHEEL ARCH

76A Right rear wheel arch

76B Rear brake cooling duct

IM Screws 1.7 x 3.5 mm (x6)

BM Screws 2.0 x 4 mm (x4)



ASSEMBLY DIAGRAM

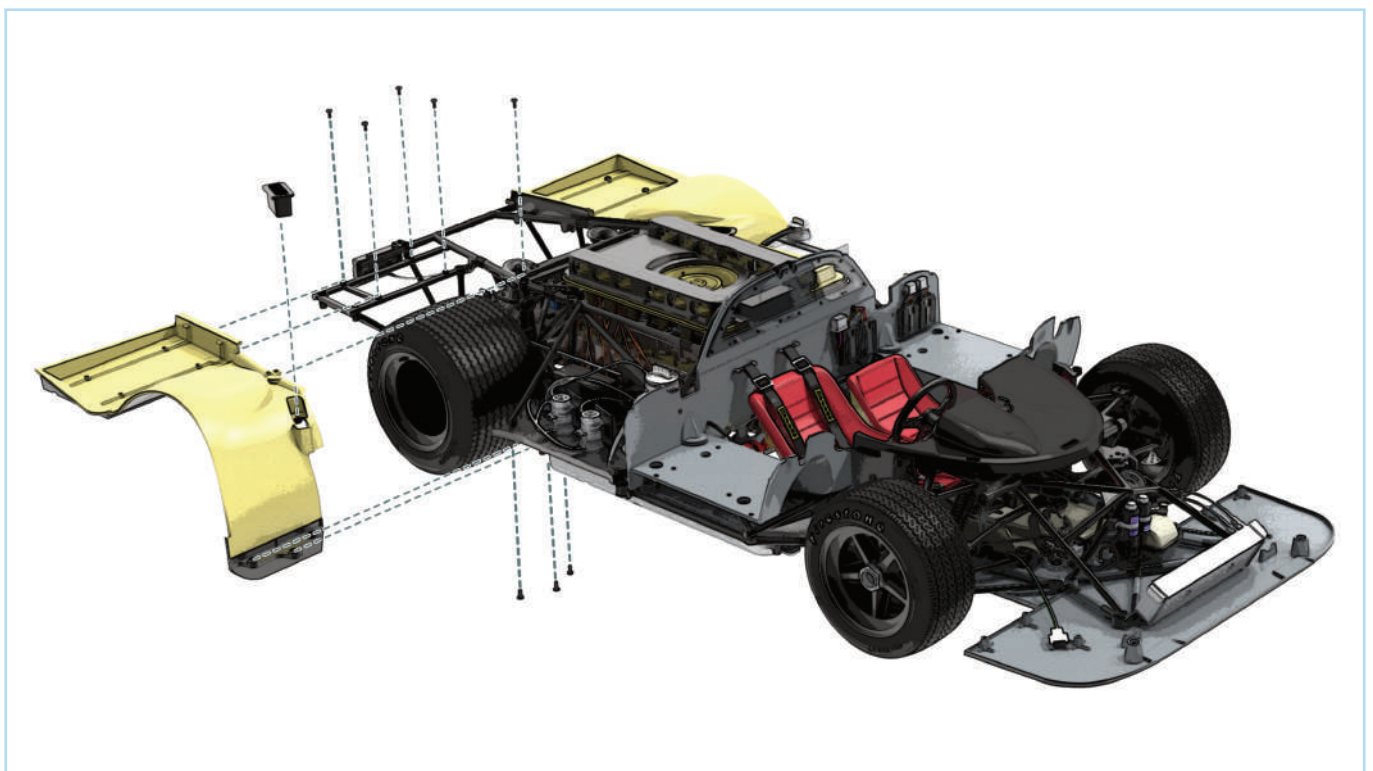

STAGE 76: FITTING THE RIGHT REAR WHEEL ARCH

STEP 1

Fit the **rear brake cooling duct (76B)** into the **right rear wheel arch (76A)**. Position the wheel arch onto the **upper frame (47A)** while fitting its front section under the **right chassis plate (73A)**.

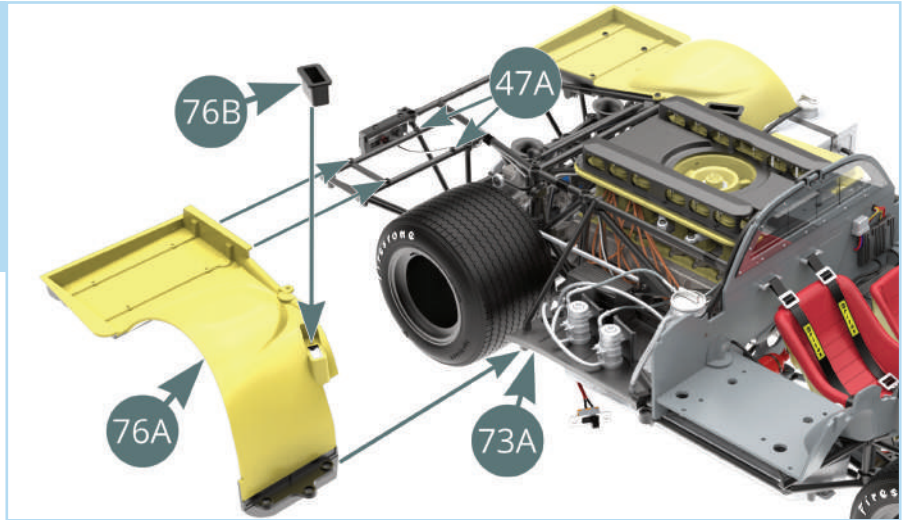

Secure the **right rear wheel arch (76A)** to the **upper frame (47A)** using five **IM** screws.

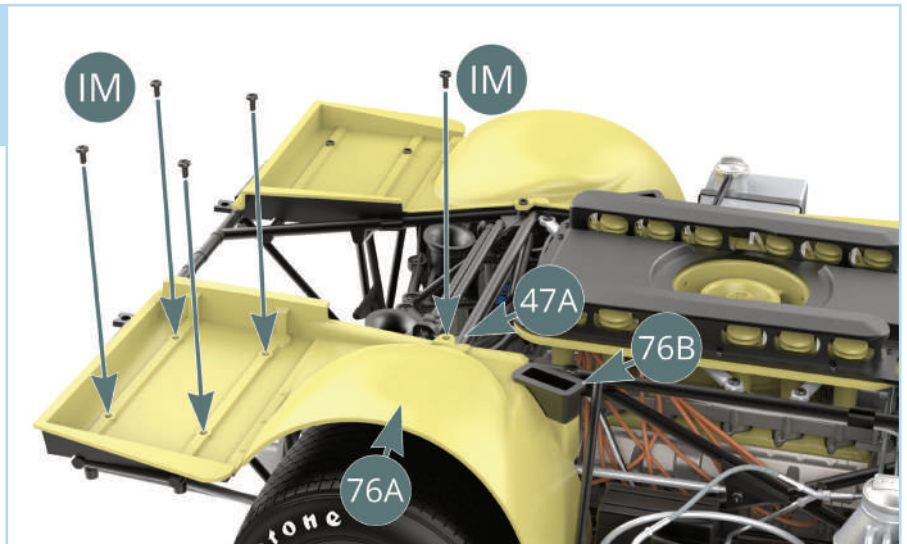

STEP 2

Turn the assembly over and fix the front of the wheel arch to the **right chassis plate (76A)** using three **BM** screws.

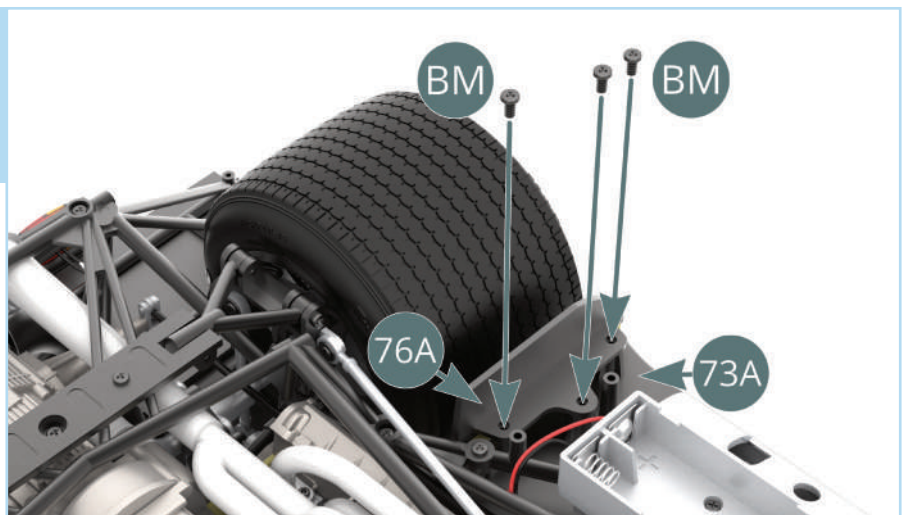

STAGE 76: FITTING THE RIGHT REAR WHEEL ARCH

STAGE COMPLETE

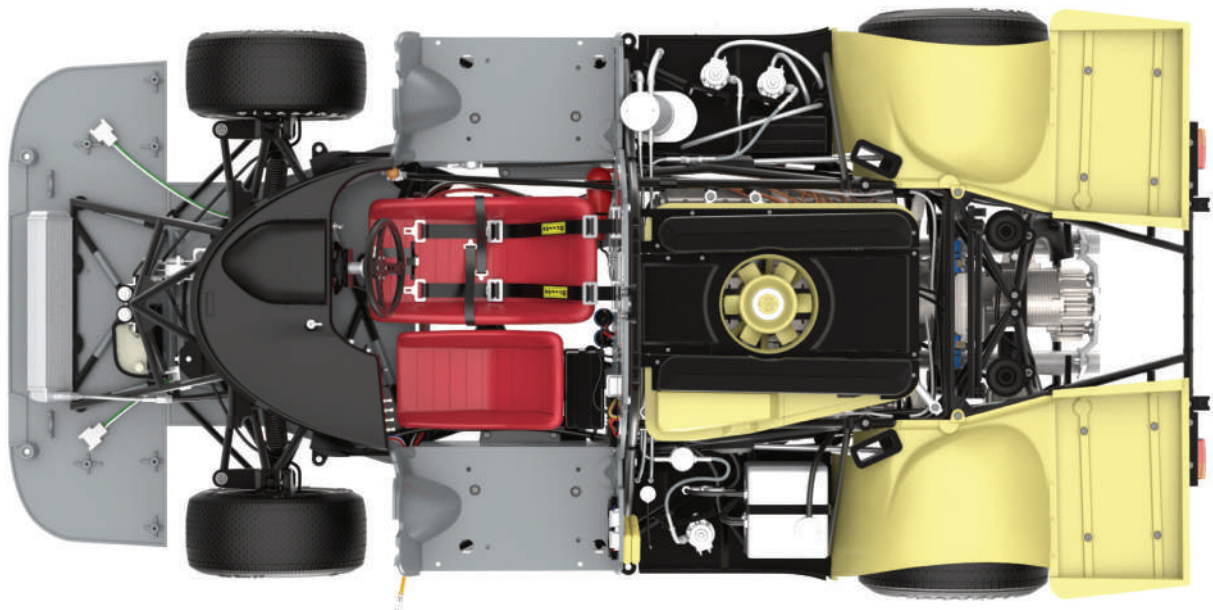
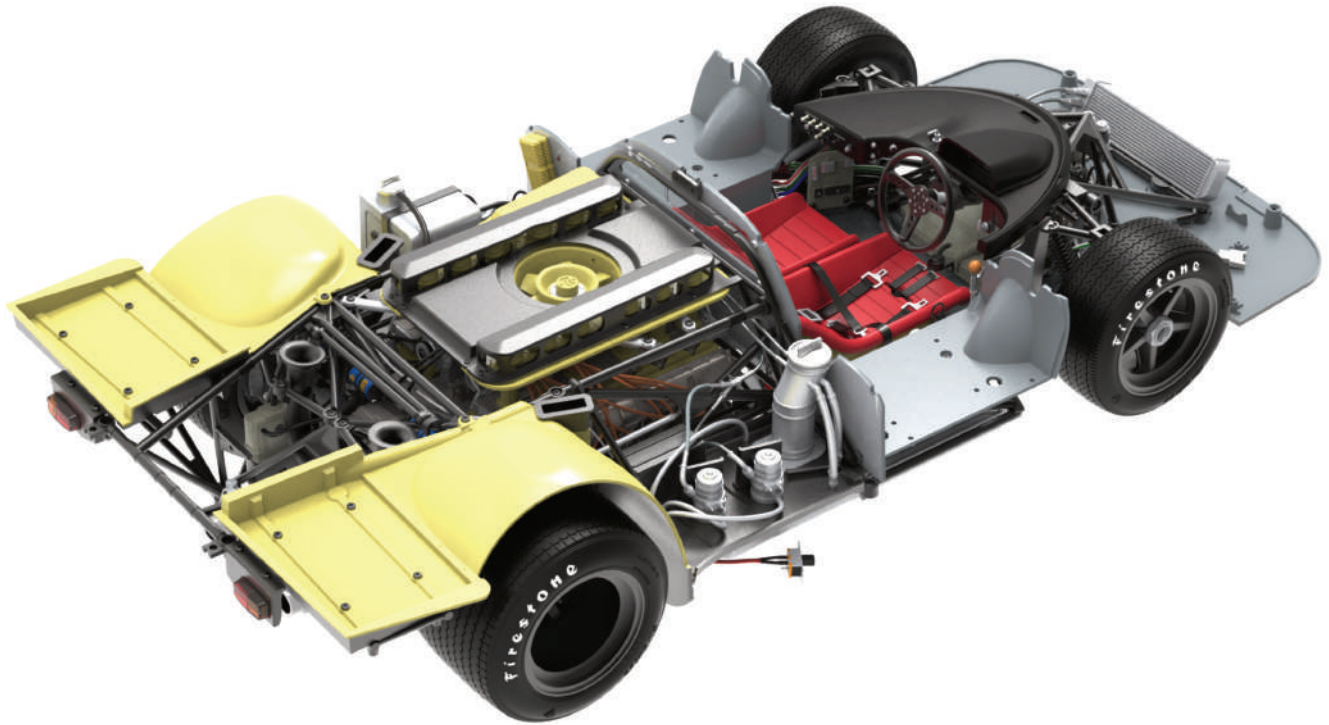

STAGE 77: ASSEMBLING AND INSTALLING THE SPARE WHEEL

77A Spare wheel tyre

BM Screws 2.0 x 4 mm (x4)

77B Spare wheel outer rim

77C Spare wheel inner rim

77D Spare wheel strap

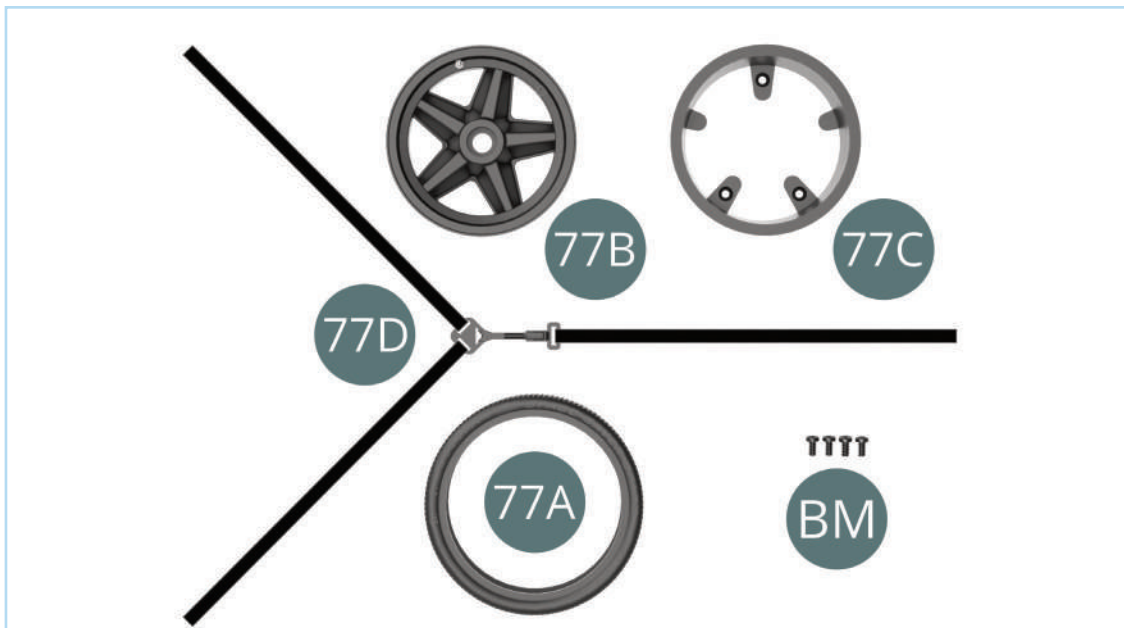

ASSEMBLY DIAGRAM

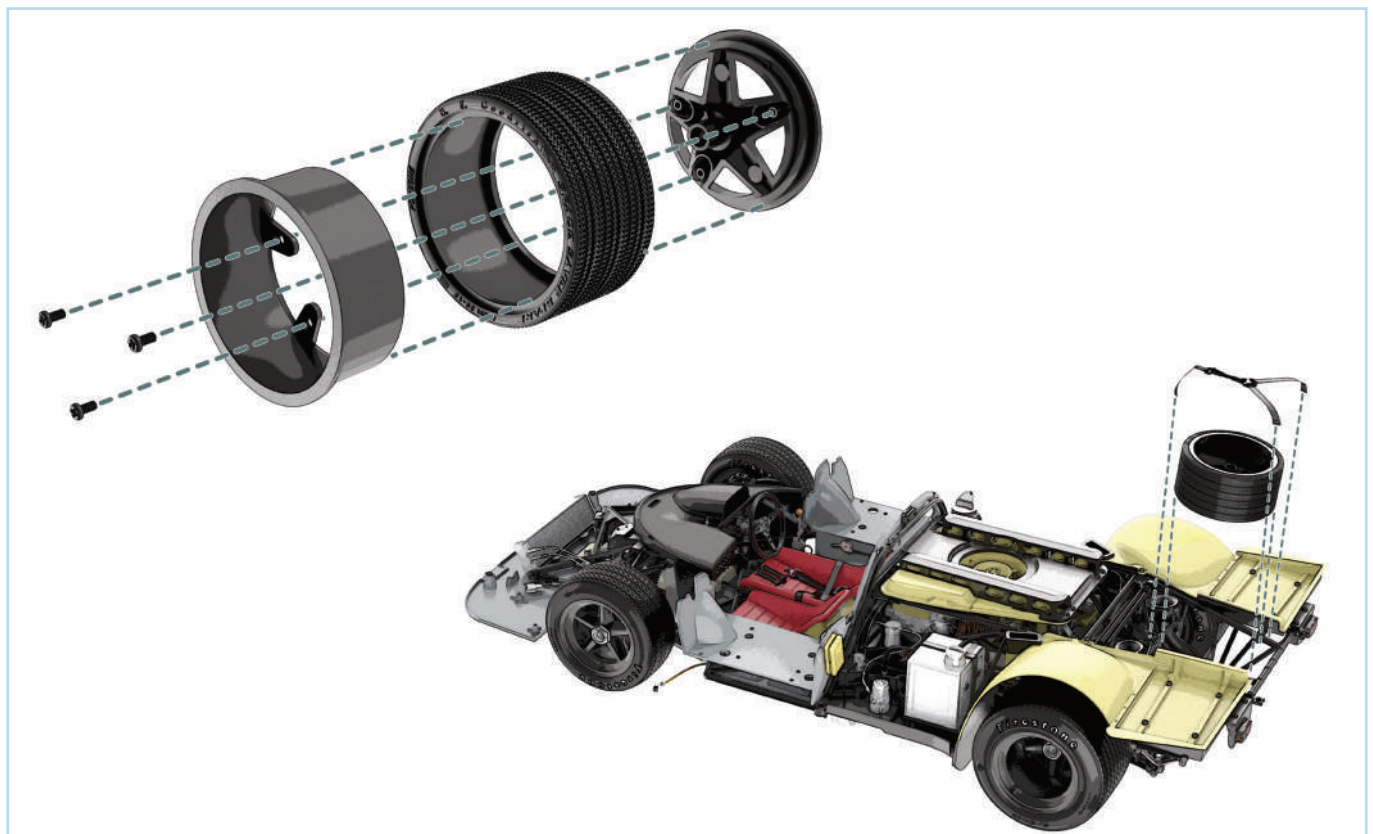

STAGE 77: ASSEMBLING AND INSTALLING THE SPARE WHEEL

STEP 1

Take the **spare wheel outer rim (77B)** and press it into the **spare wheel tyre (77A)**.

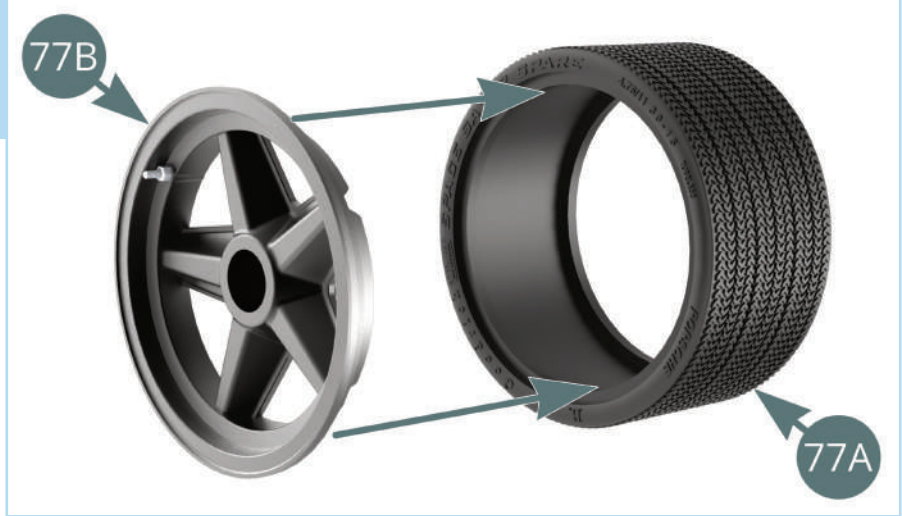

Position the **spare wheel inner rim (77C)** into the tyre, aligning the screw holes with the outer rim. Secure in place using three **BM** screws.

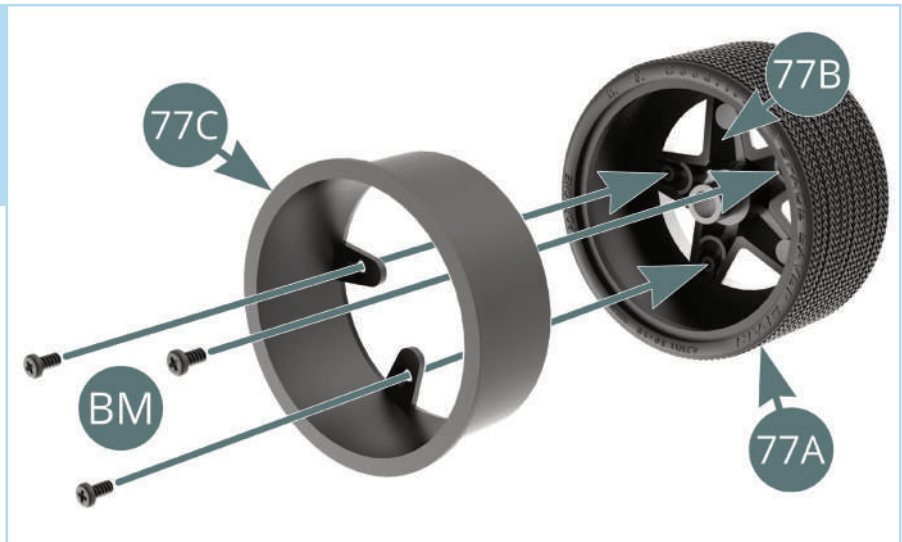

STEP 2

Take the **spare wheel strap (77D)**. There is a quick release lever which will attach to the spare wheel when fitted. As shown by the arrows, the lever must face up (red arrow) once in place over the spare wheel, while the flat section will face down (green arrow).

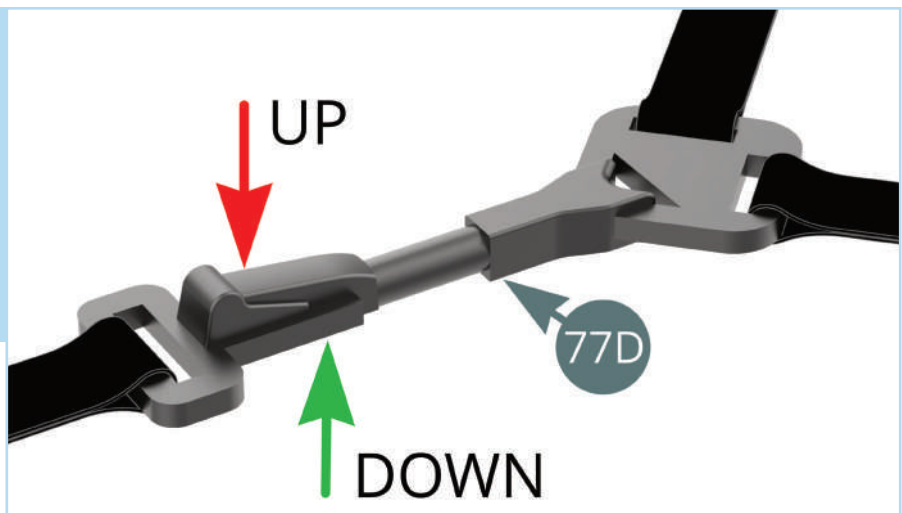

STAGE 77: ASSEMBLING AND INSTALLING THE SPARE WHEEL

Lay the **spare wheel strap (77D)** over the **upper frame (47A, highlighted white)** with the flat section facing upwards (green arrow). Tie the strap to the upper frame as shown (highlighted red). Do not tie the knot fully for now. Note the recess for positioning the spare wheel on the **reinforcement frame (45A)**.

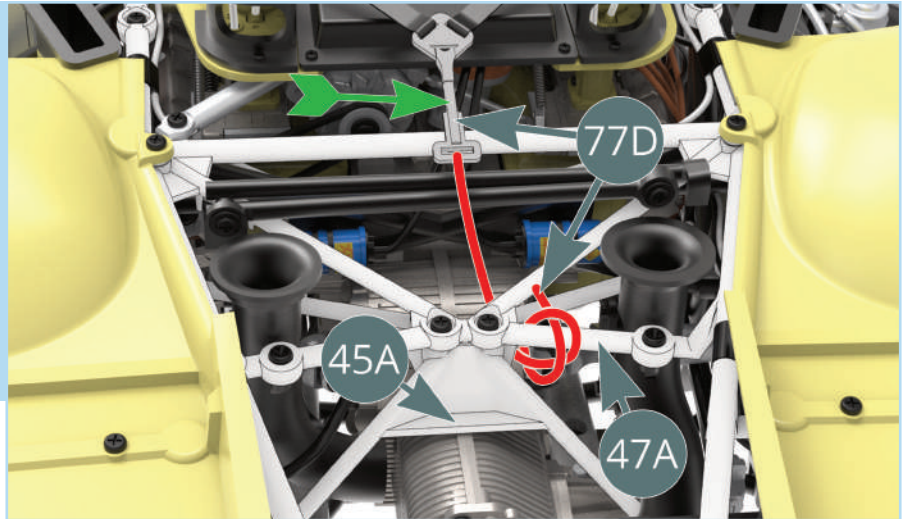

STEP 3

Position the **spare wheel tyre (77A)** into the recess in the **reinforcement frame (45A)**, with the outer rim of the wheel facing downwards as shown.

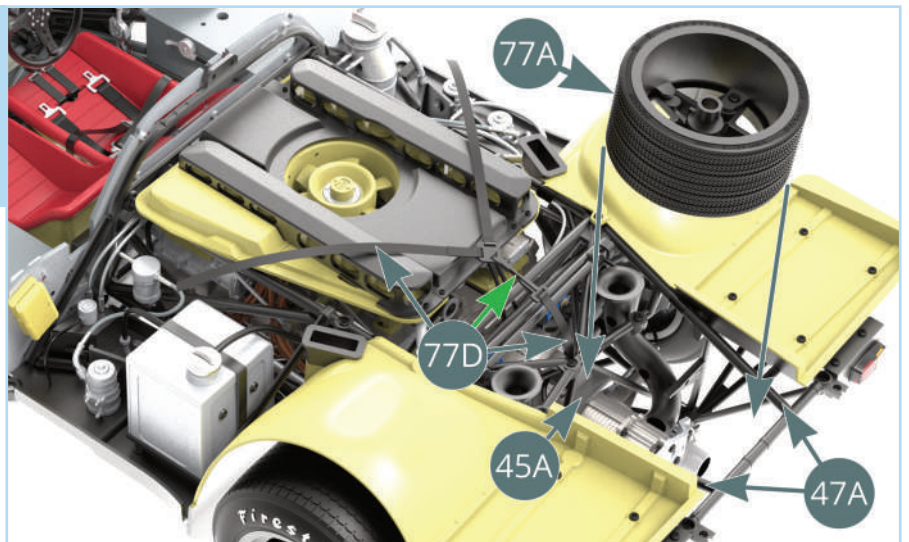

Take the **spare wheel strap (77D)** and fold it into place cooling pipes over the tyre. The quick release lever should now be facing upwards (red arrow). Adjust the tightness of the first strap (green arrow) so that the quick release lever is in position above the wheel as shown. Tie the loose ends of the strap (highlighted blue) to the upper frame to secure the wheel in place. Once secure, wrap any excess strapping around the frame and tuck away neatly.

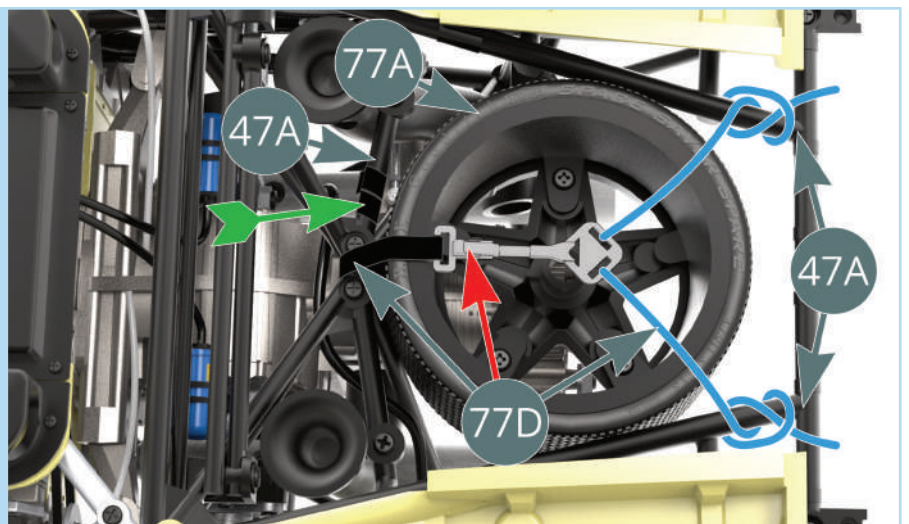

STAGE 77: ASSEMBLING AND INSTALLING THE SPARE WHEEL

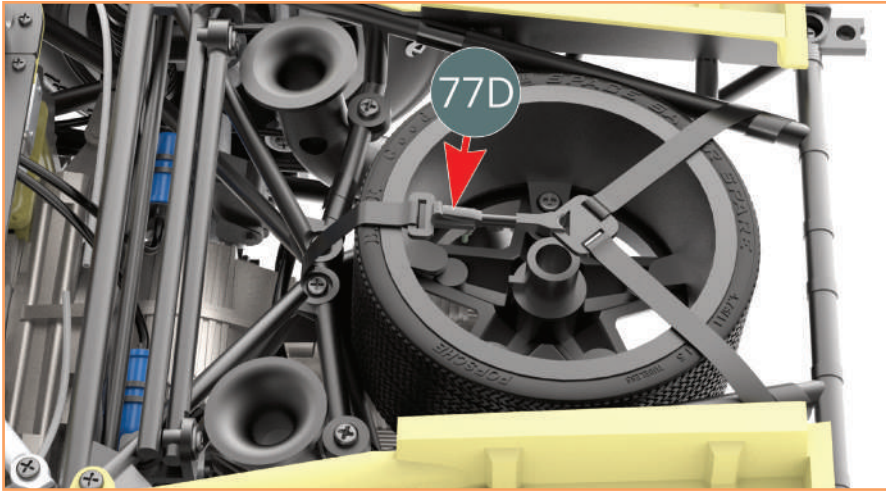

The spare wheel should look like this once it has been secured with the strap. The quick release lever (red arrow) is now facing upwards.

STAGE COMPLETE

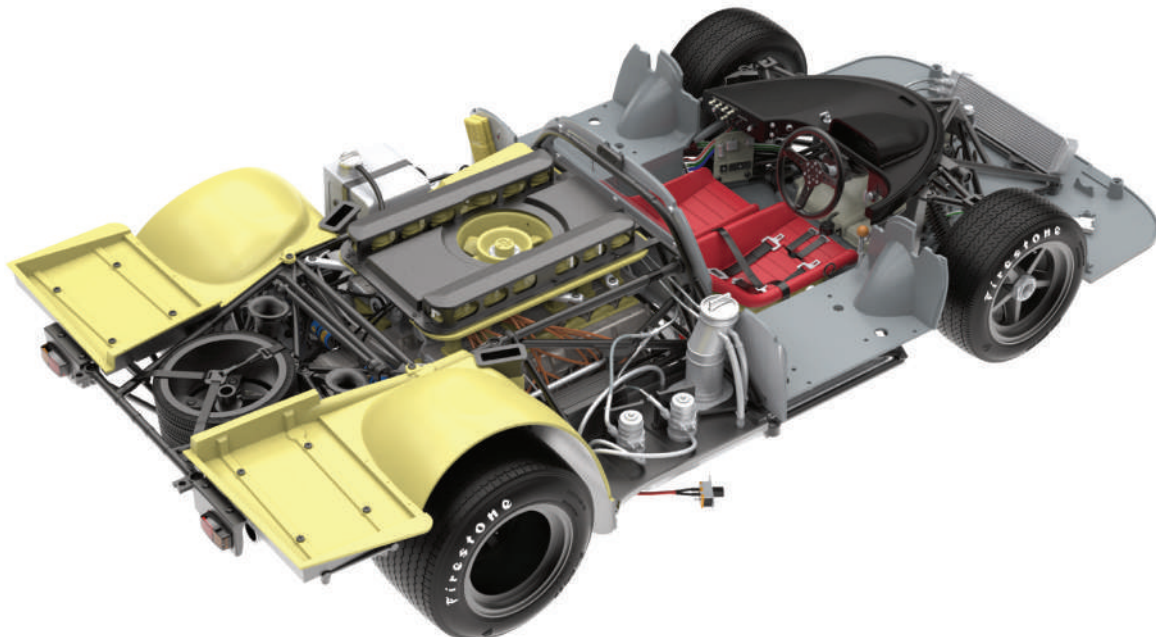

STAGE 78: INSTALLING THE FRONT BRAKE COOLING PIPES

78A Front left brake cooling pipe

78B Front right brake cooling pipe

78C Model support (x4)

The brake cooling pipes are slightly different from each other: the short curved ends (arrow) rise upwards. Check the assembly diagram below to identify the left from the right pipe.

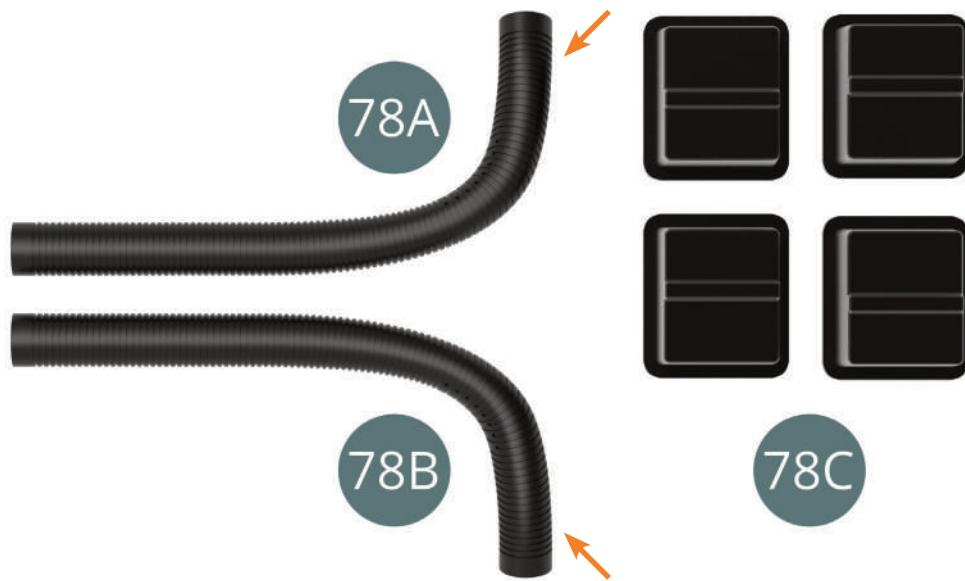

ASSEMBLY DIAGRAM

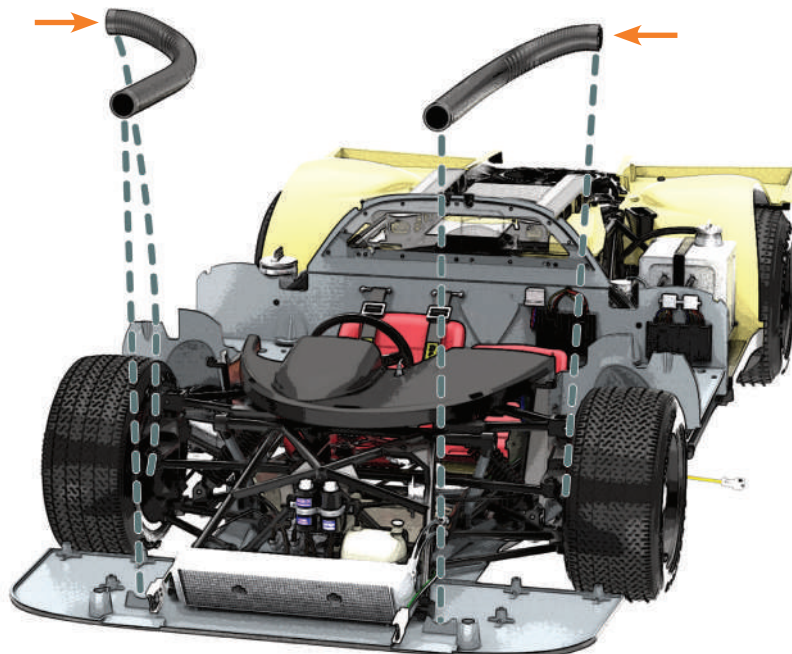

STAGE 78: INSTALLING THE FRONT BRAKE COOLING PIPES

STEP 1

Locate the intake on the **right brake disc cooling air duct (30I)**, shown here from underneath, of the front right wheel (arrow).



With the assembly upright on your work surface, fit the curved end of the **front right brake cooling pipe (78B)** onto the intake.

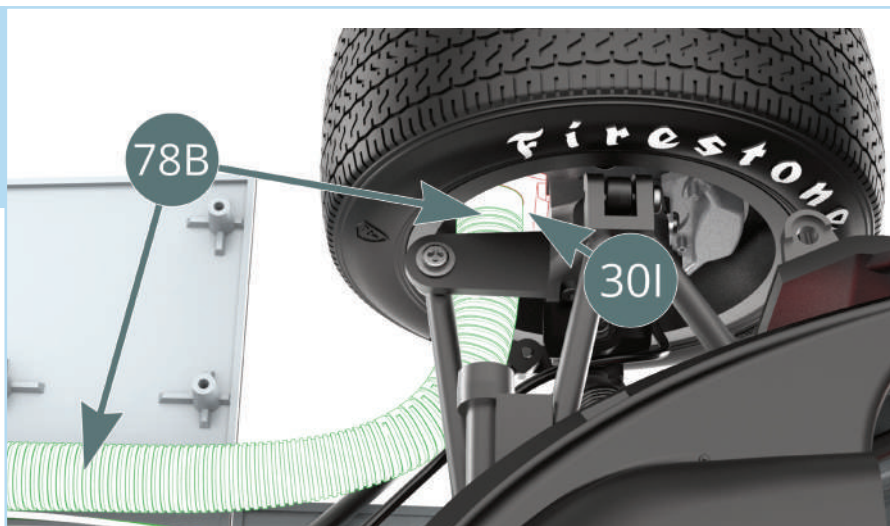

STEP 2

On the front left wheel, find the intake on the **left brake disc cooling air duct (30C)**.



STAGE 78: INSTALLING THE FRONT BRAKE COOLING PIPES

Fit the **front left brake cooling pipe (78A)** onto the intake in the same way as before.

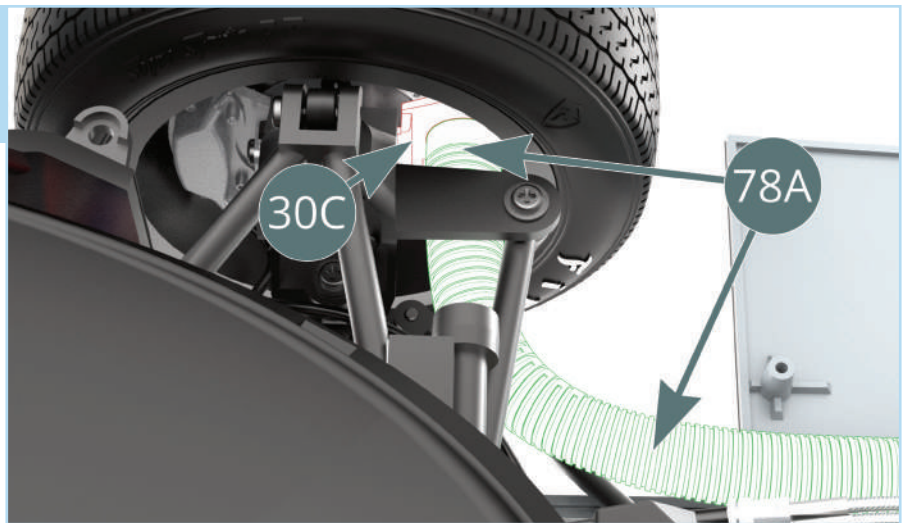

STEP 3

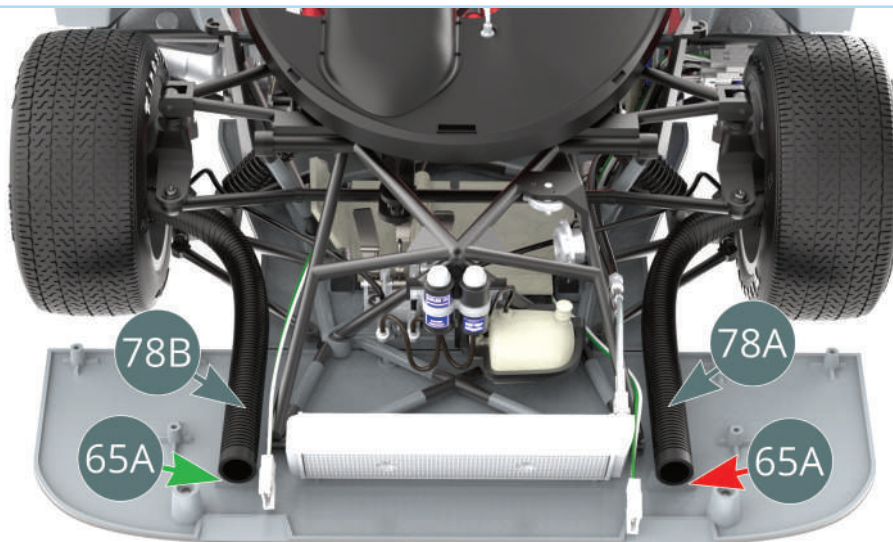

Adjust the **right (78B)** and **left (78A) brake cooling pipes** so that they rest in their respective slots (green and red arrows) of the **front floor panel (65A)**.

STAGE 78: INSTALLING THE FRONT BRAKE COOLING PIPES

STAGE COMPLETE

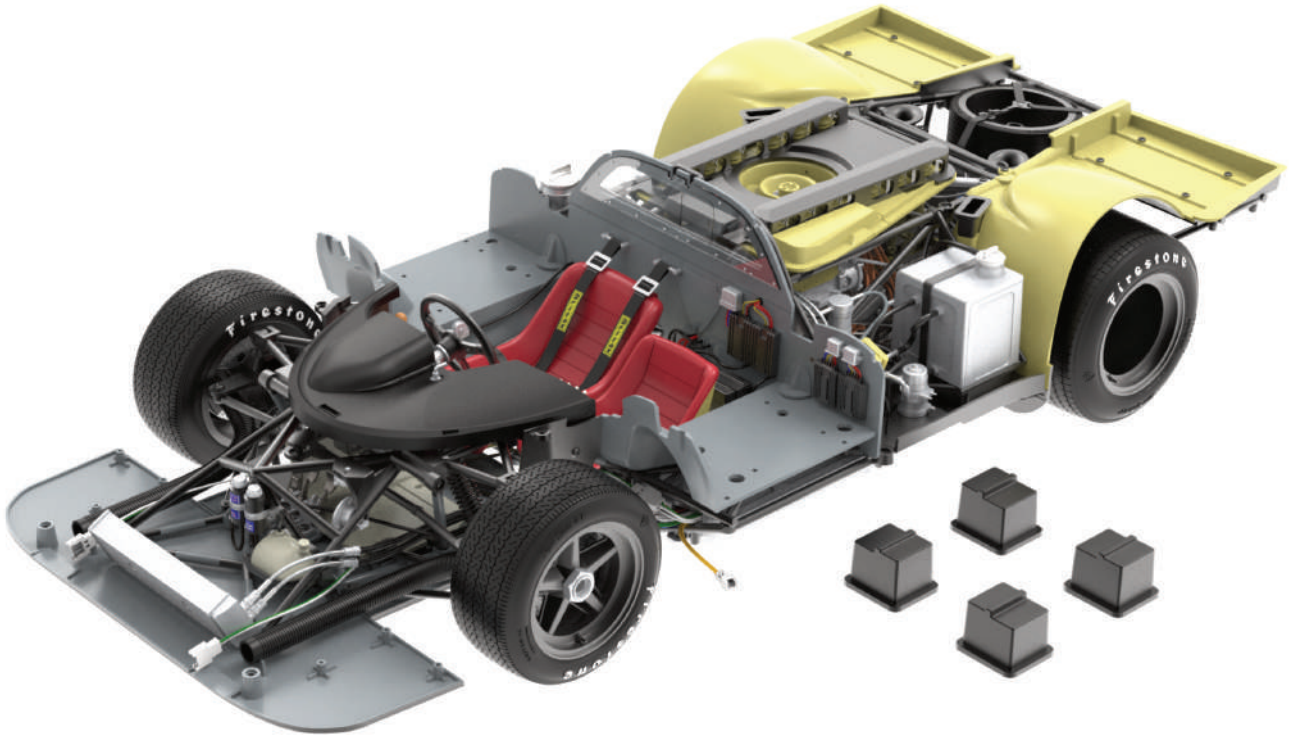

STAGE 79: FITTING THE FRONT WHEEL ARCHES TO THE FRONT FLOOR PANEL

79A Front left wheel arch

IM Screws 1.7 x 3.5 mm (x8)

79B Front right wheel arch



ASSEMBLY DIAGRAM

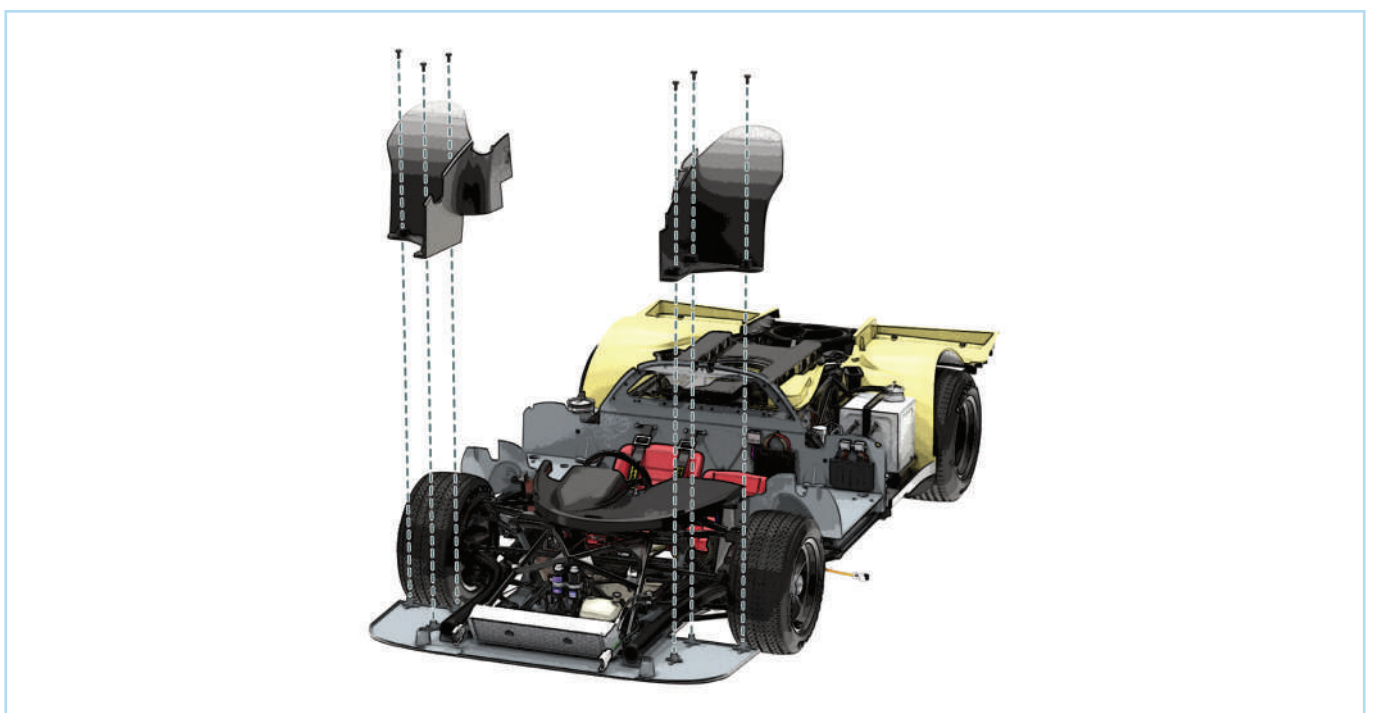

STAGE 79: FITTING THE FRONT WHEEL ARCHES TO THE FRONT FLOOR PANEL

STEP 1

Align the **front left wheel arch (79A)** with the **front floor panel (65A)** as shown, then fit the screw holes over the raised posts of the panel. Make sure not to trap the wire of the headlights when fitting the arch (arrow). While supporting the front panel from underneath, secure the arch using three **IM** screws.

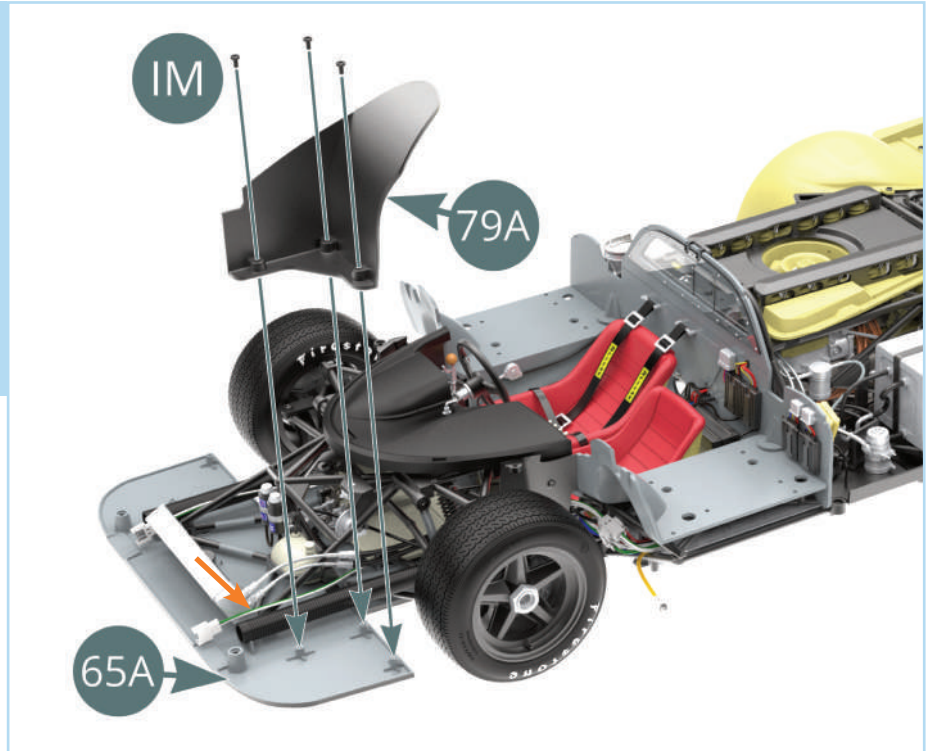

Fit the **front right wheel arch (79B)** onto the **front floor panel (65A)** in the same way and secure using three **IM** screws.

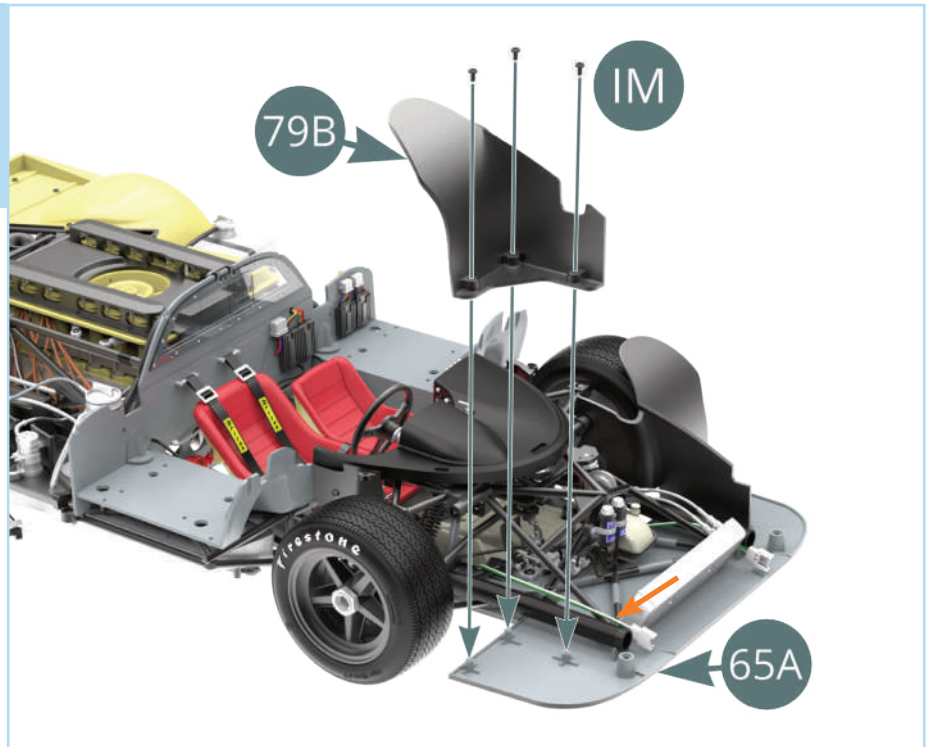

STAGE 79: FITTING THE FRONT WHEEL ARCHES TO THE FRONT FLOOR PANEL

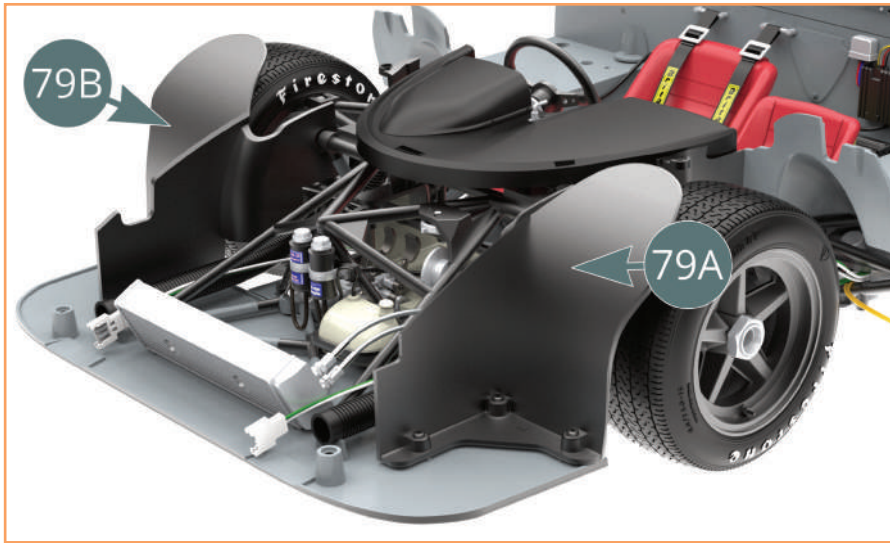

The left and right front wheel arches have been fitted onto the front floor panel.

STAGE COMPLETE

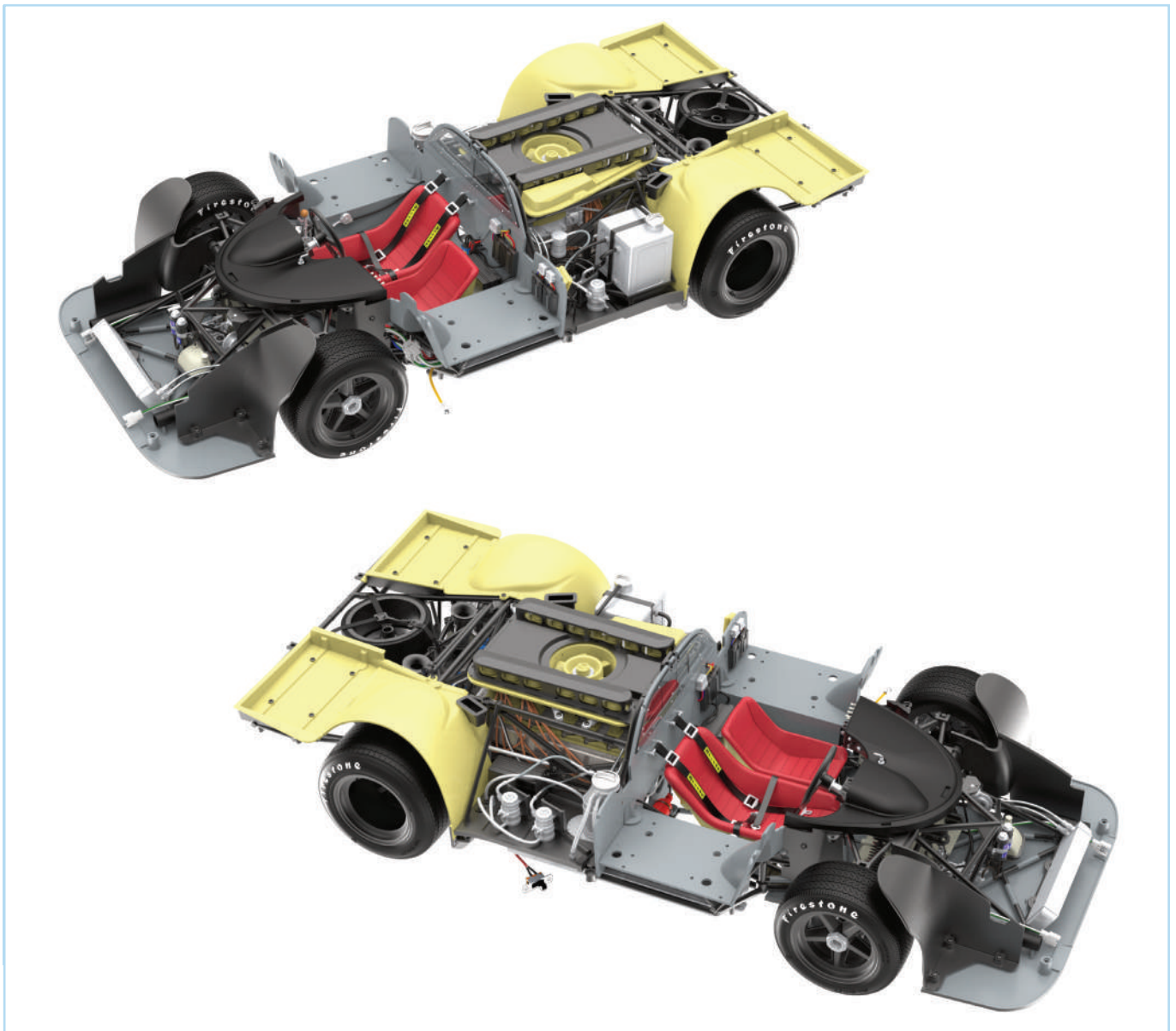

STAGE 80: PREPARING THE FRONT BODY

80A Front body

This stage involves removing the cross support from the front body. If you prefer, you can leave the front body safely in its packaging for now and remove the cross support once the front body is needed in a later stage.

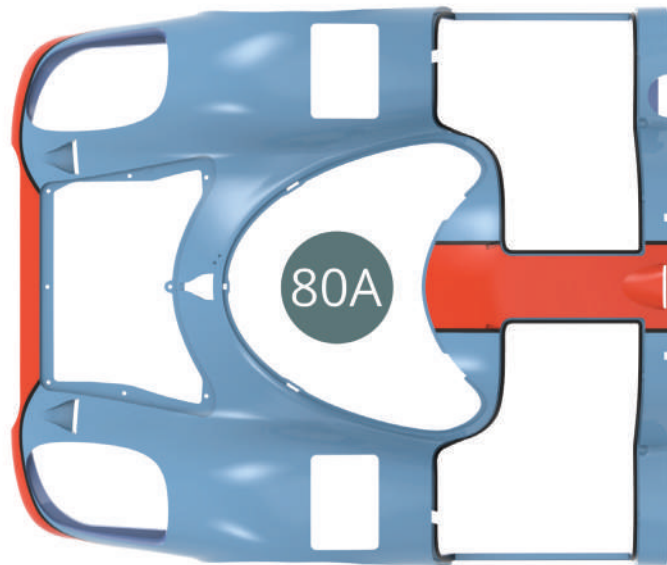

ASSEMBLY DIAGRAM



STAGE 80: PREPARING THE FRONT BODY

STEP 1

Take the **front body (80A)** and place it on your work surface upside down. Remember to use a protective surface to avoid damaging the paint. Remove the screw at each end of the cross support as shown by the red arrows in the two images.

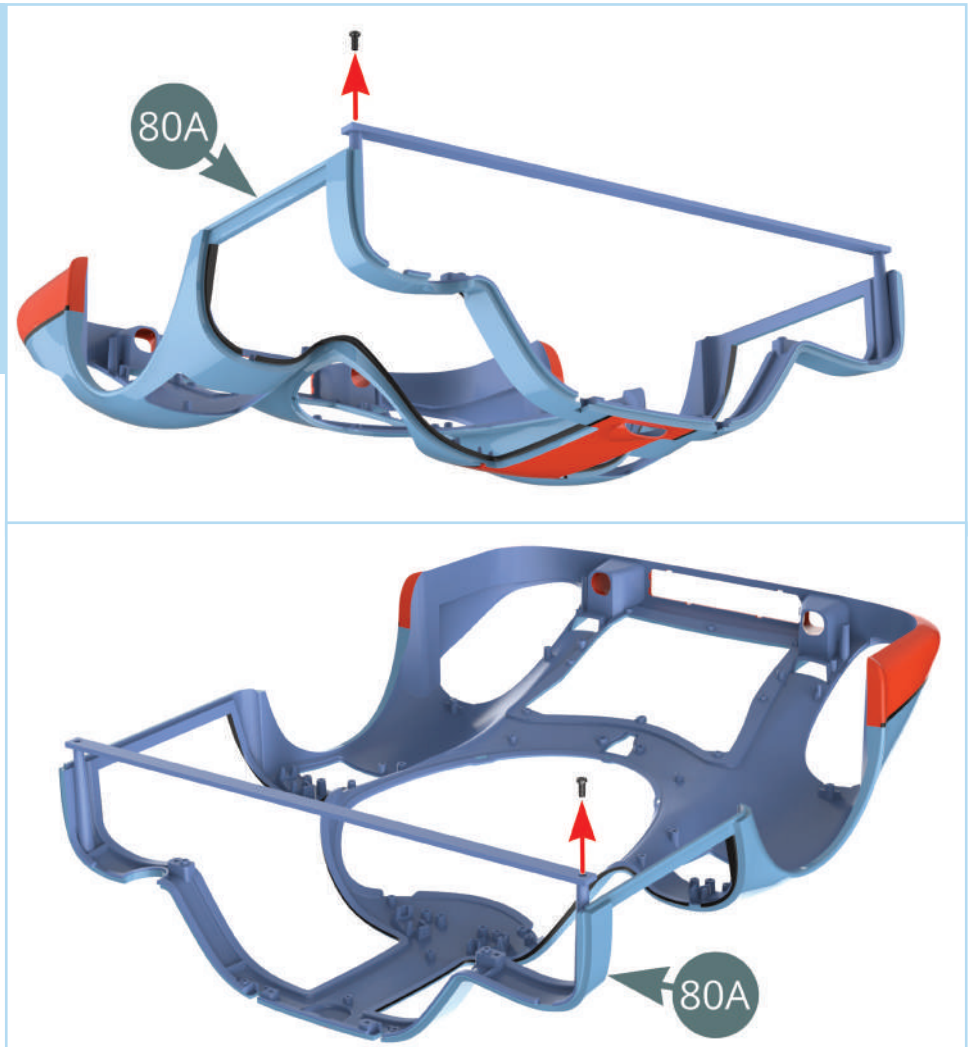

STEP 2

Detach the cross support from the **front body (80A)**, as shown by the red arrows.

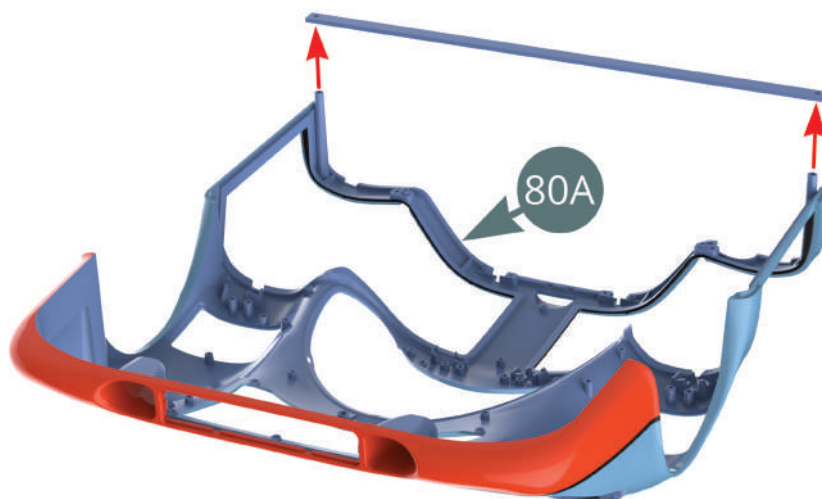

STAGE 80: PREPARING THE FRONT BODY

STAGE COMPLETE

