



# Lamborghini MIURA



## Pack 02

### BUILD INSTRUCTIONS

**STAGE 07: BUILDING THE  
LEFT CYLINDER HEAD**

**STAGE 08: INSTALLING COVER BOLTS**

**STAGE 09: BUILDING THE RIGHT CYLINDER  
HEAD AND ATTACHING SIDE COVERS**

**STAGE 10: ASSEMBLING THE RIGHT AIR FILTER  
BOX AND FITTING THE DISTRIBUTORS**

**STAGE 11: LEFT CARBURETTOR (1)**

**STAGE 12: LEFT CARBURETTOR (2)**

**STAGE 13: ATTACHING THE  
SPARK PLUG CABLES**

**STAGE 14: RIGHT CARBURETTOR (1)**

**STAGE 15: RIGHT CARBURETTOR (2)**

The "Automobili Lamborghini" and "Automobili Lamborghini Bull and Shield" trademarks, copyrights, designs and models are used under license from Automobili Lamborghini S.p.A, Italy.

## Advice from the experts

---

Spare screws are included with each part. Occasionally, you may be instructed to keep spare or unused screws for a later stage. Keep these spares in a safe place and label them correctly.

Please make sure you don't mix up the screws. They look quite similar, but the threads do vary slightly. Using the wrong screws may damage the parts.

When securing parts together using multiple screws, fit each screw loosely to ensure all the parts are correctly aligned before gently tightening them firmly, but not overtight, in the order in which you placed them.

The screwdriver can be magnetized by stroking it with a magnet (fridge magnet, etc.) enabling it to hold the screws and make assembly easier.

If a screw is tight going into a metal part, do not force it as you may shear the head off. Remove it and put a tiny smear of Vaseline, soap or light oil on the thread. That will lubricate it and make it easier to drive home.

During the course of this build, you will receive many pieces that you will assemble immediately – following the instructions in the corresponding stage – and other pieces that you should store safely to one side, for use in future assembly stages.

Left and Right! When building your Lamborghini, the left or right hand side refers to each side as you are sitting in the car.



**WARNING:** Some parts are assembled using magnets. These magnets can cause serious injury if they are swallowed. Keep away from children. If you suspect a magnet has been swallowed, seek medical help straight away.

## Advice from the experts

The Lamborghini Miura features a transverse mid-mounted V12 engine, with the crankshaft axis perpendicular to the direction of travel. Some of the engine parts will be referred to as left and right in the build instructions, though the engine will be mounted transversely.

The photo below shows the assembled parts which are labelled so that you can refer to it during your build. The inset photos show the different ends of the left and right cylinder head to help with differentiating the two.

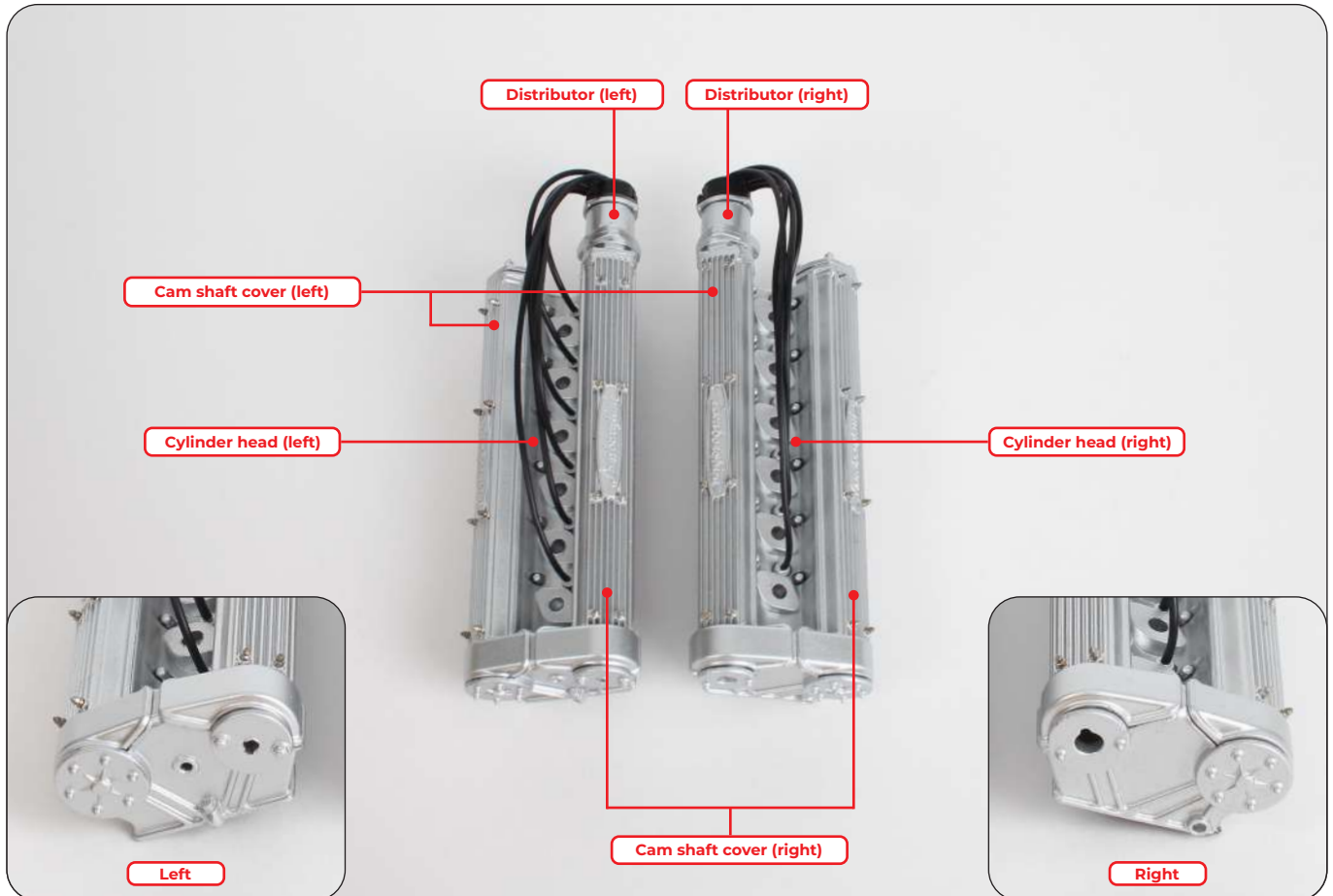

## Stage 07: Building the Left Cylinder Head

In this first stage for Pack 02, you'll assemble the left cylinder head and install the covers onto it.

The Lamborghini shield emblem supplied will not be used in this pack, so can be stored away safely.

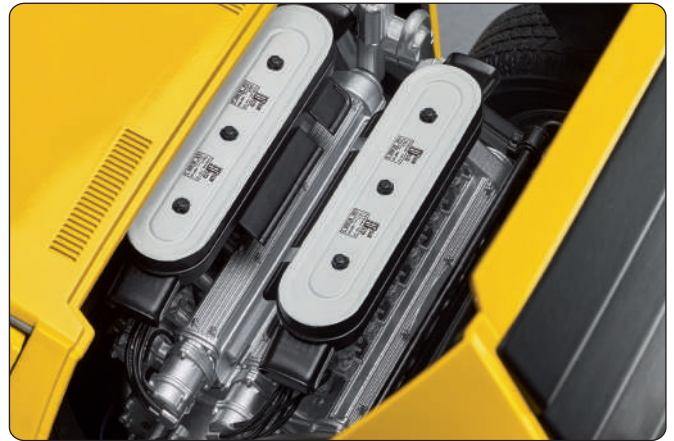

### STAGE 07 PARTS LIST

Name
Cylinder head (left)
Cam shaft cover (left)
Cam shaft cover (right)
Lamborghini shield emblem
Model tweezers
Cover bolt x20



## Stage 07: Building the Left Cylinder Head

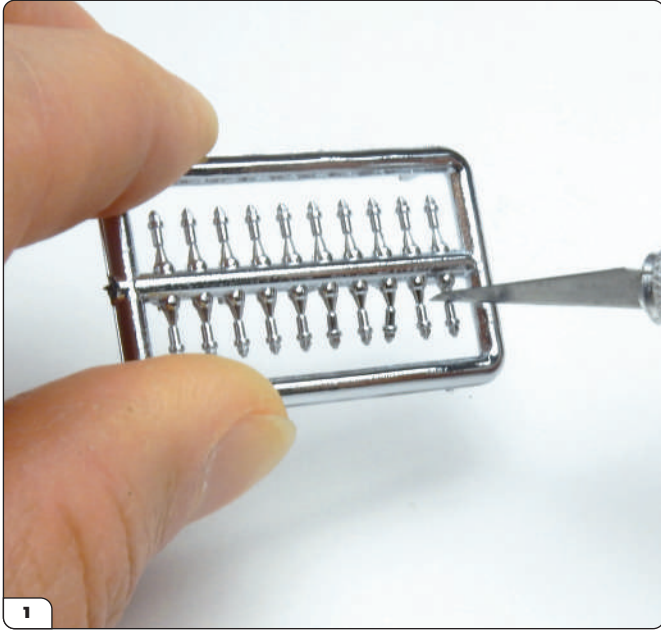

Carefully cut sixteen cover bolts from their sprue at the point shown in the photo.

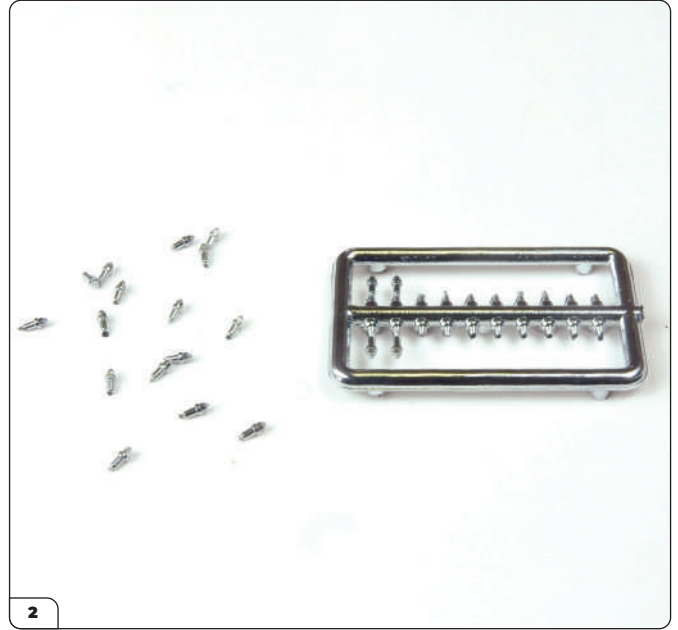

There are four spare bolts, which can be left on the sprue unless they are needed.

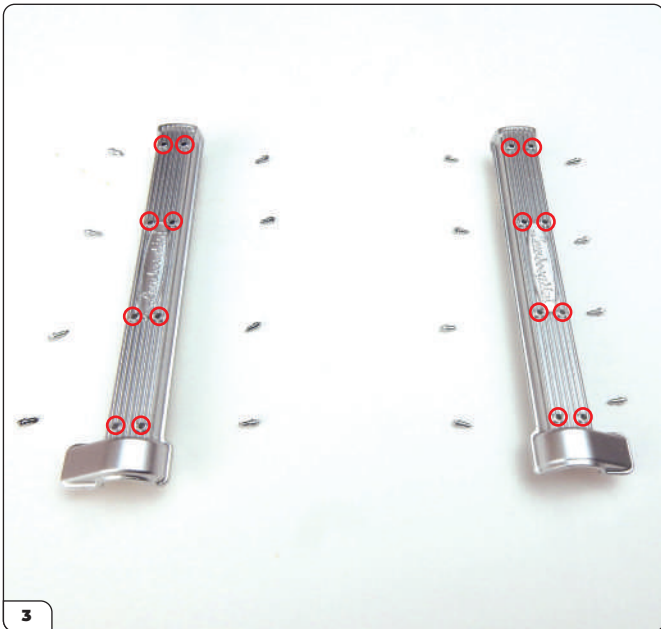

Take the two cam shaft covers and lay them on your work surface as shown. There are eight holes (circled) in each cover into which the bolts will be inserted.

Note: you may need to twist the blade of a sharp modelling knife around the inside of the holes to remove excess paint. This should help the bolts fit in properly.

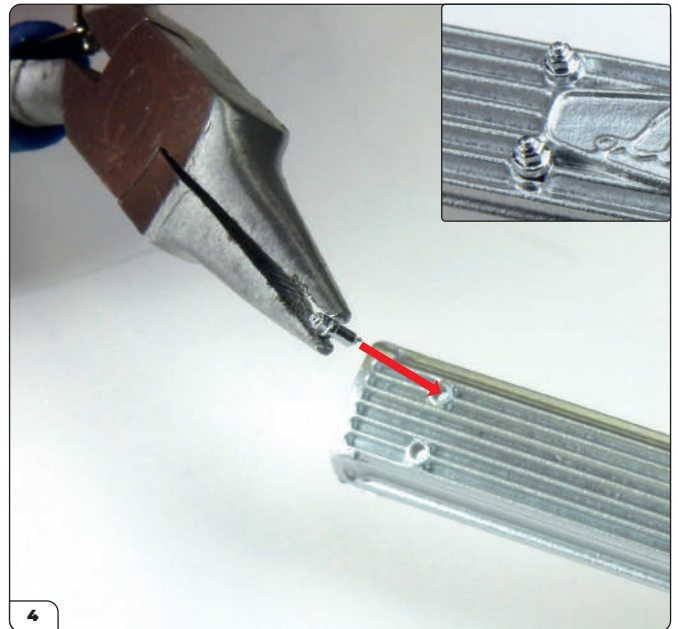

Using pliers or tweezers, carefully grasp a bolt and fit into one of the holes (arrow). The long smooth end of the bolt is fitted into the hole, leaving the bolt's hex head visible (inset).

Tip: if the bolt won't press in, try swivelling it until you find a better fit. You can use the flat face of the tweezer handle to press the bolts flush. Some of the bolts may need super gluing in place.

## Stage 07: Building the Left Cylinder Head



Continue to press bolts into the other holes of the cover.

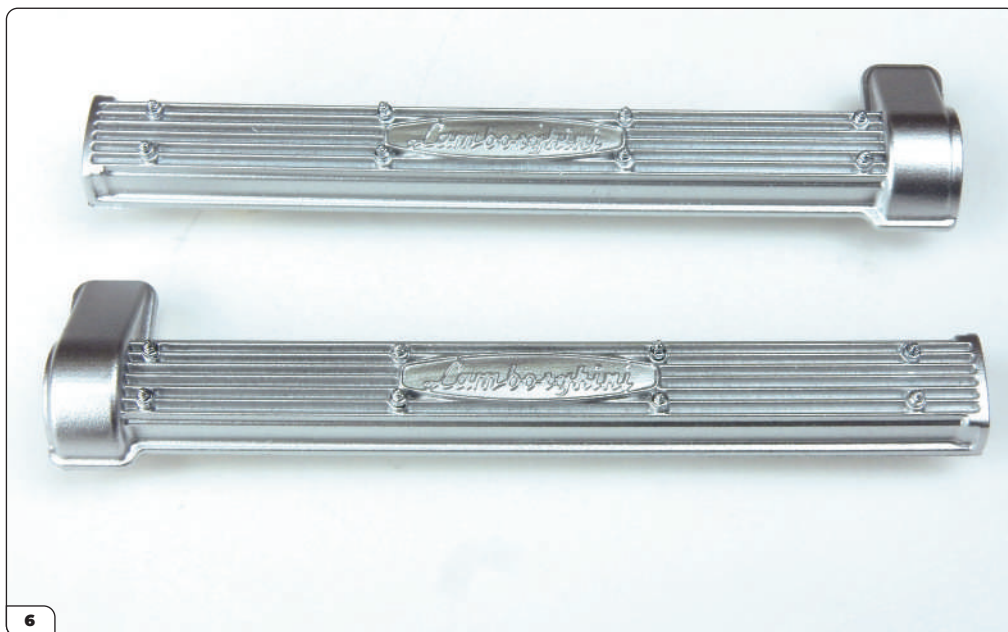

Repeat for the remaining bolts in the other cam shaft cover until all sixteen have been fitted.

## Stage 07: Building the Left Cylinder Head

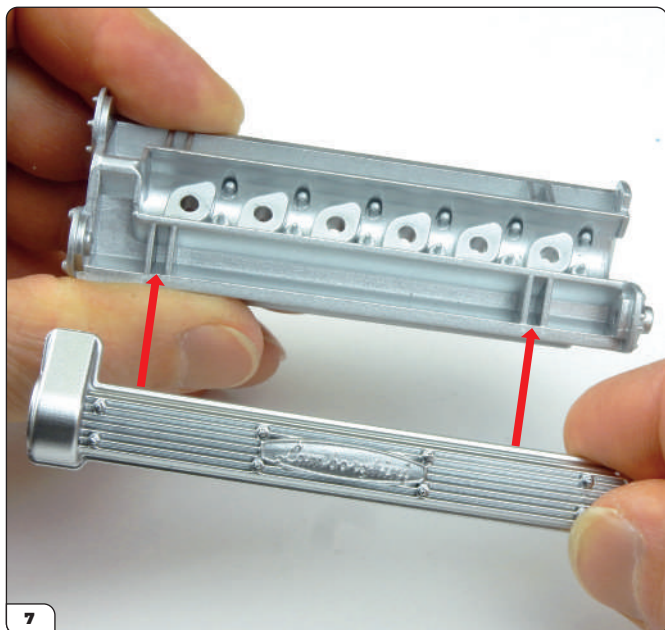

Next take the cylinder head and align the cam shaft cover (right) with the slots for mounting as shown (arrows).

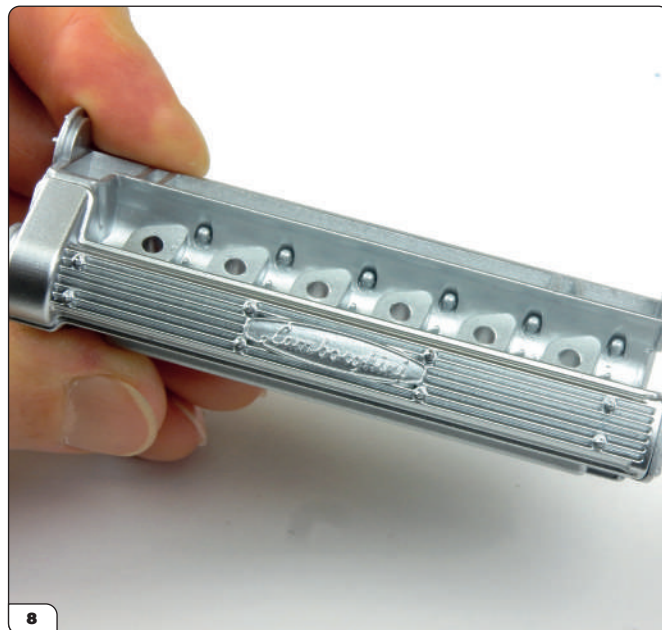

Firmly press the cam shaft cover into place, checking the fit is flush around the edges.

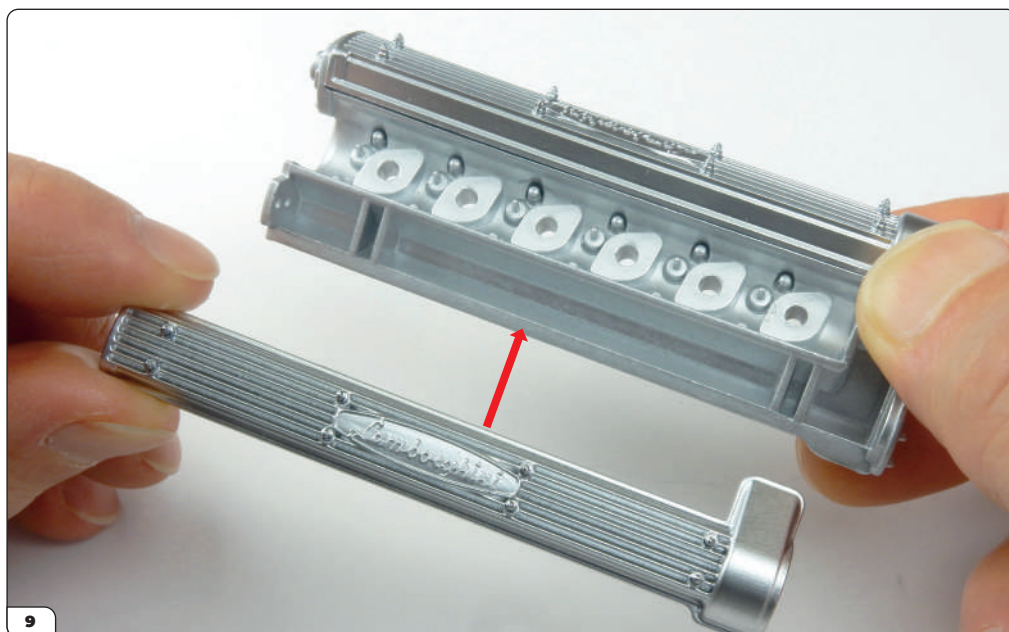

Take the cam shaft cover (left) and align it with the other side of the cylinder head. Press the cover firmly into place.

## Stage 07: Building the Left Cylinder Head

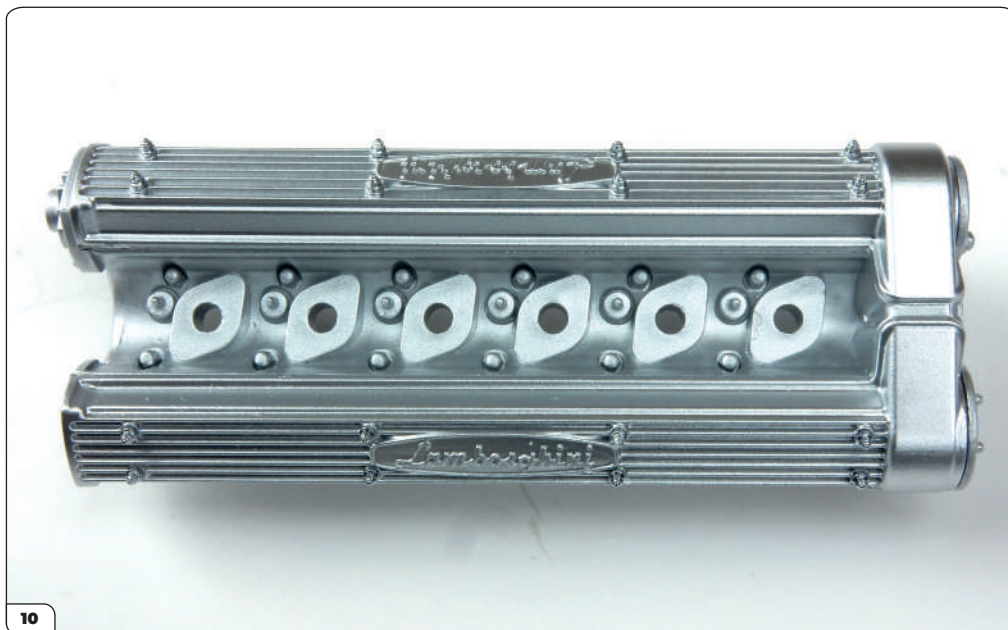

The left cylinder head should look like this with both covers and all of the bolts installed.

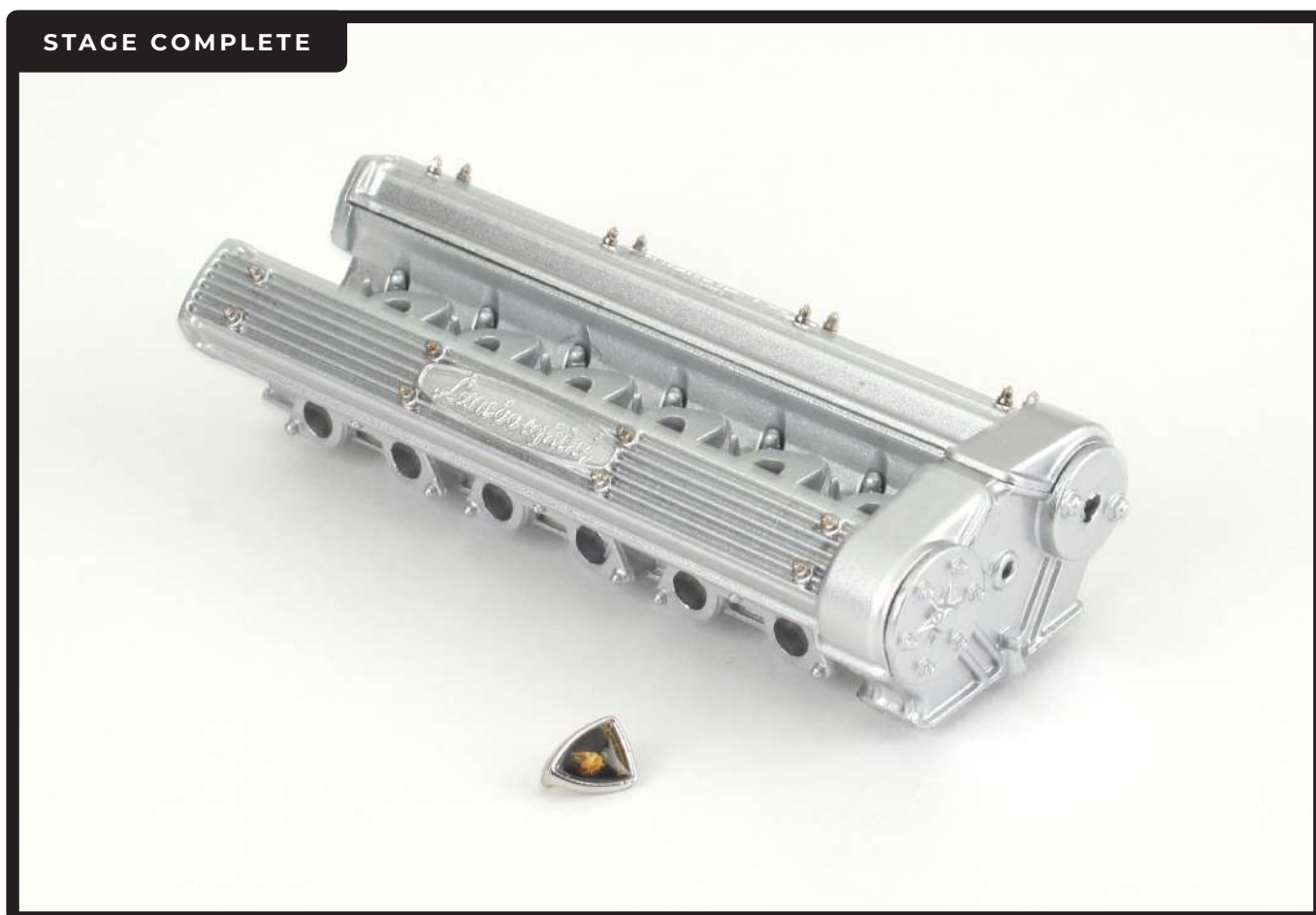



# Stage 08: Installing Cover Bolts

Next you will install sixteen cover bolts into the next set of covers ready for the right cylinder head.

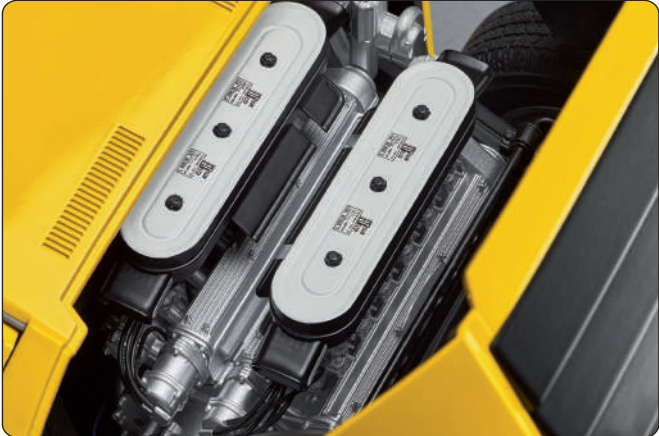

## STAGE 08 PARTS LIST

Name
Cover bolt x20
Cam shaft cover (left)
Cam shaft cover (right)

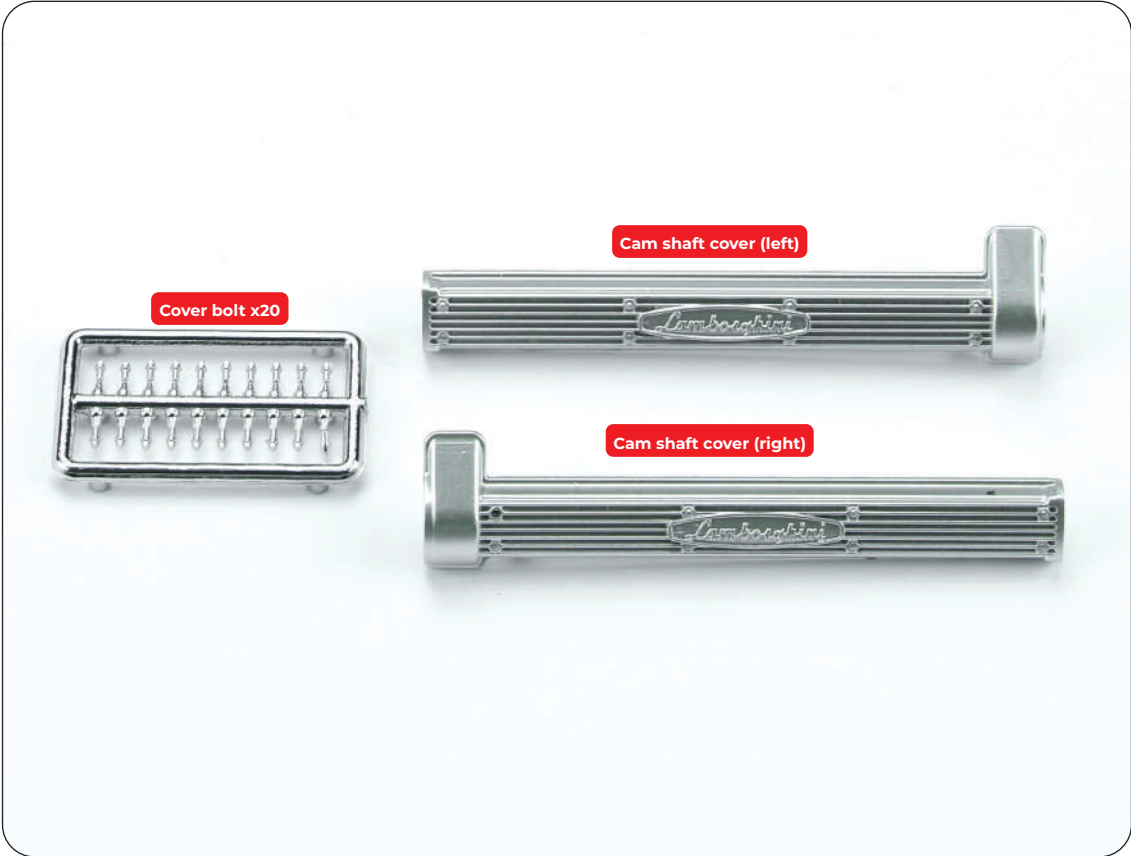

## Stage 08: Installing Cover Bolts

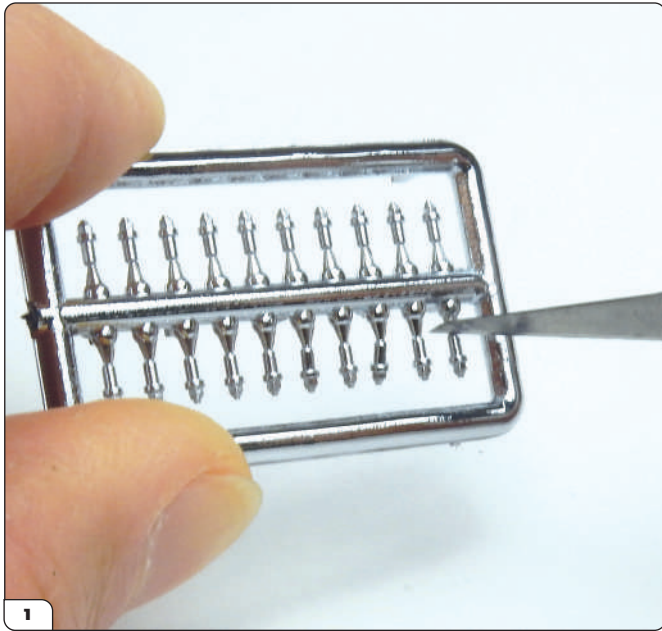

Carefully cut sixteen cover bolts from their sprue at the point shown in the photo.



There are four spare bolts, which can be left on the sprue unless they are needed.



Locate the sixteen holes on the cam shaft covers (circled).

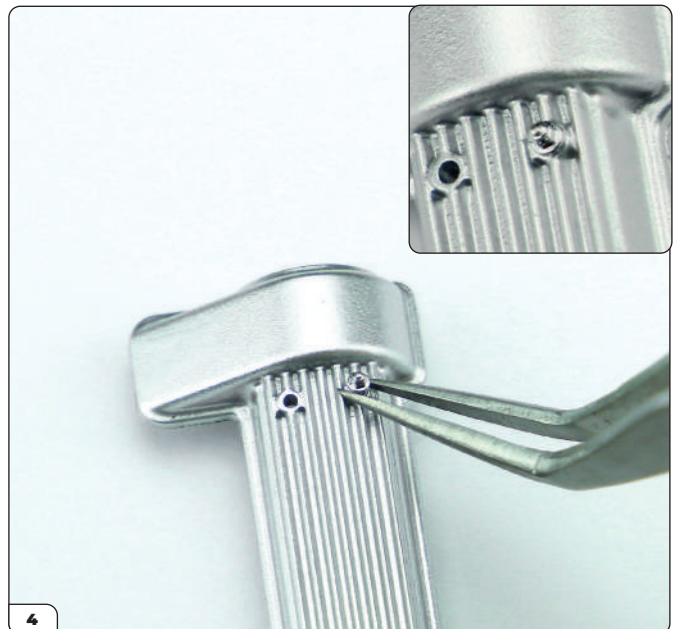

Using pliers or tweezers, carefully grasp a bolt by the ring around it and fit into one of the holes as shown. The long smooth end of the bolt is fitted into the hole, leaving the bolt's hex head visible (inset).

## Stage 08: Installing Cover Bolts

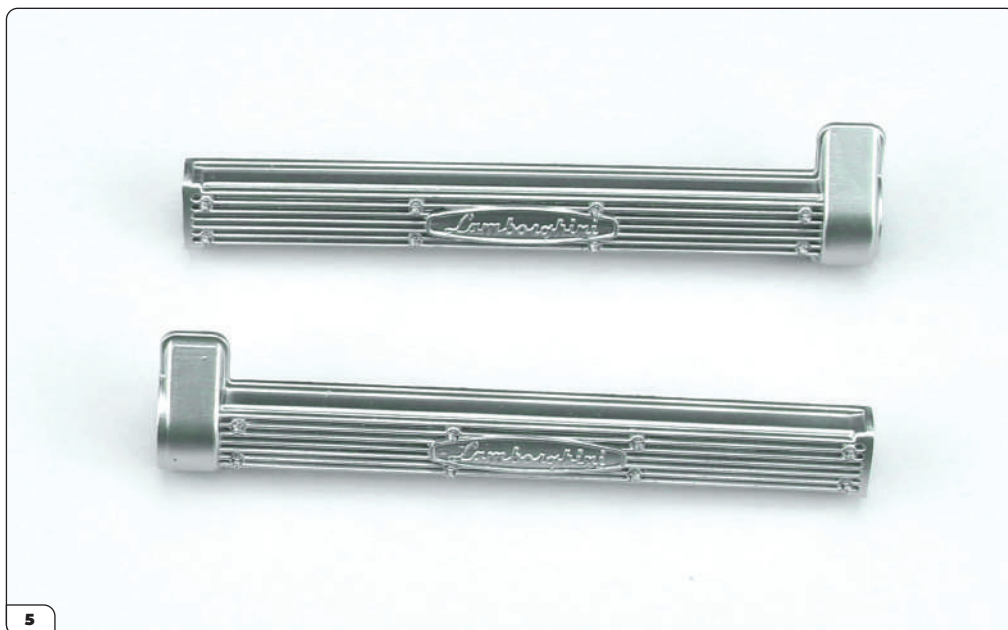

Continue to fit bolts to install all sixteen into the cam shaft covers. Use a small amount of super glue if necessary to keep the bolts in place.

**STAGE COMPLETE**



## Stage 09: Building the Right Cylinder Head and Attaching Side Covers

For this stage you'll fit the covers onto the right cylinder head, then attach side covers to both of the cylinder heads.

You'll need the left cylinder head assembled in the first stage of this pack, as well as the cam shaft covers from the previous stage.

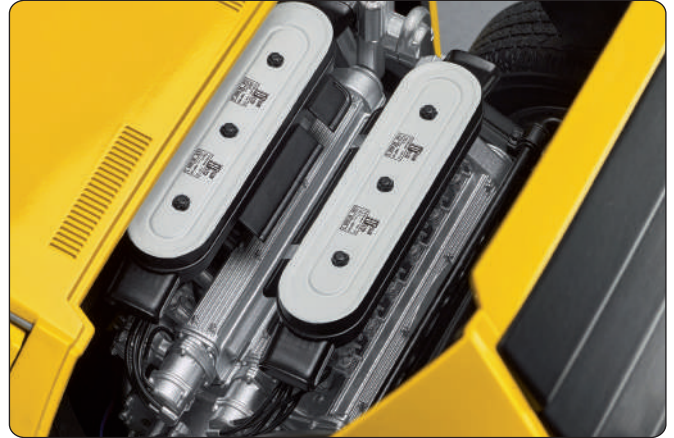

### STAGE 09 PARTS LIST

Name
Cylinder head (right)
Cylinder head side cover x2

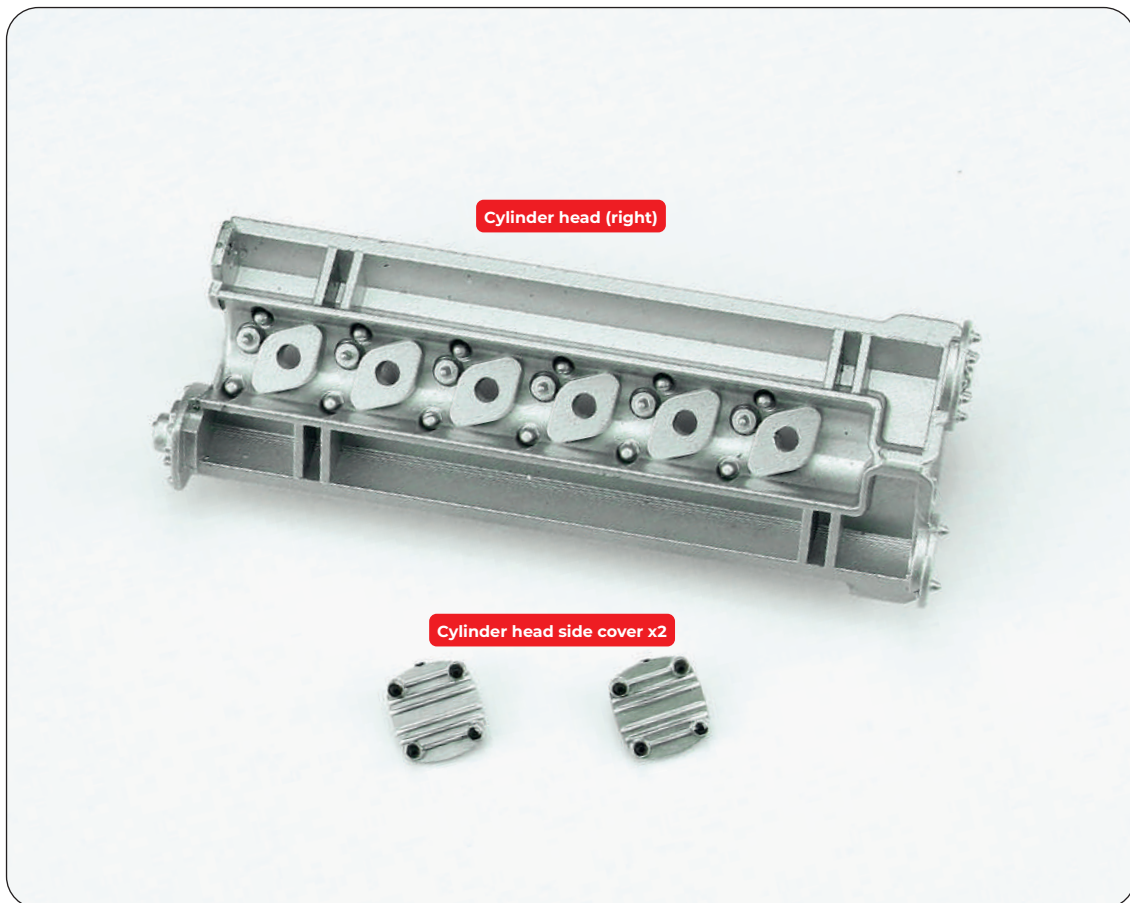

## Stage 09: Building the Right Cylinder Head and Attaching Side Covers

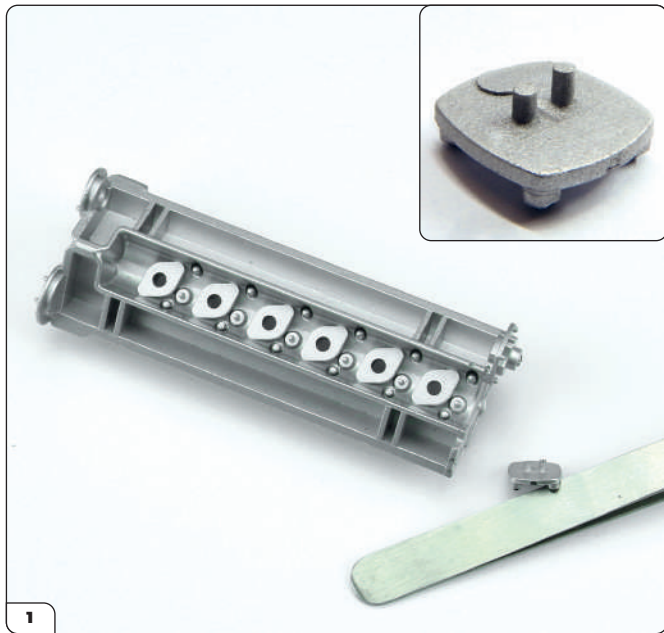

Take the cylinder head (right) and one of the side covers. On the back of the cover, note the two mounting pins (inset).

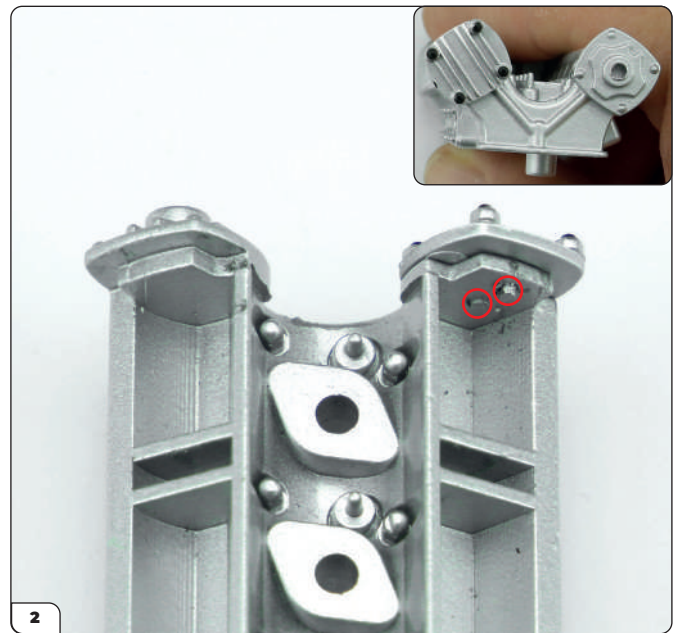

Carefully press the pins of side cover into the two holes located on the cylinder head (circled) so that the front of the cover faces outwards (inset).

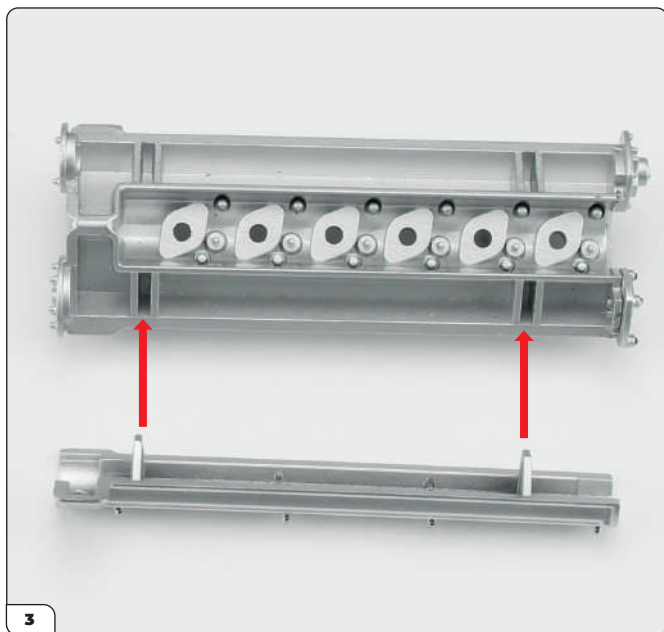

Take the right cam shaft cover from Stage 8 and align it with the cylinder head as shown.



Firmly press the cover into place.

## Stage 09: Building the Right Cylinder Head and Attaching Side Covers

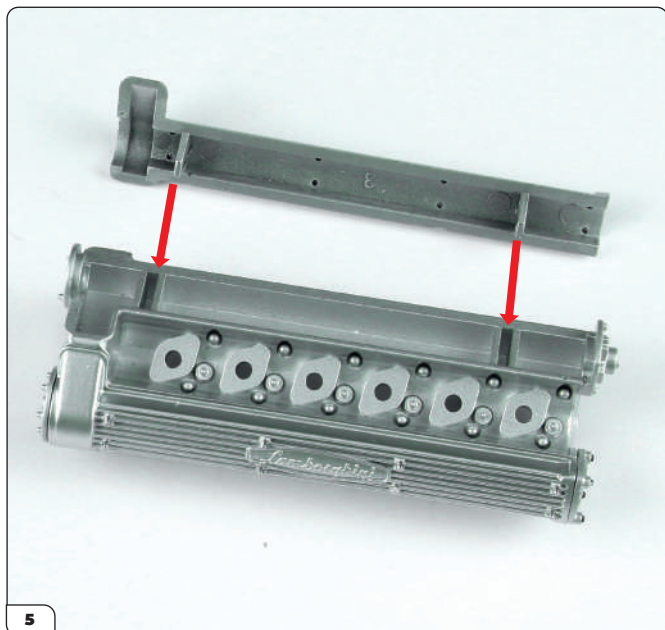

Take the right cam shaft cover from Stage 8 and align with the other side of the cylinder head.



Press the cover into place. The assembly should now look like this.

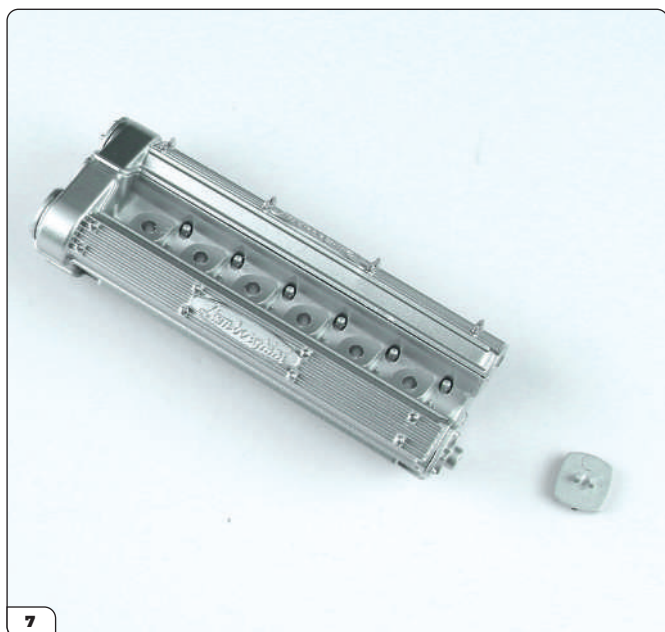

Take the left cylinder head assembly from Stage 6 and the remaining side cover.

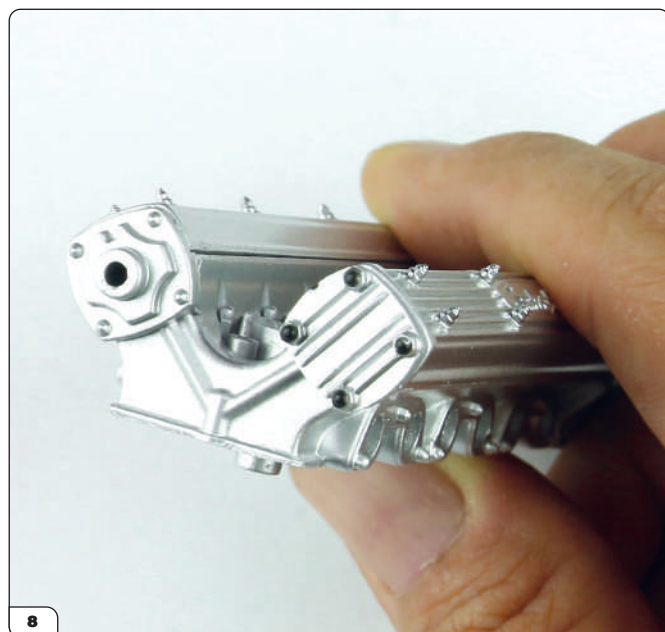

Fit the cover into the cylinder head as you did for step 2, pressing the pins of the side cover into the two holes of the cylinder head.

## Stage 09: Building the Right Cylinder Head and Attaching Side Covers

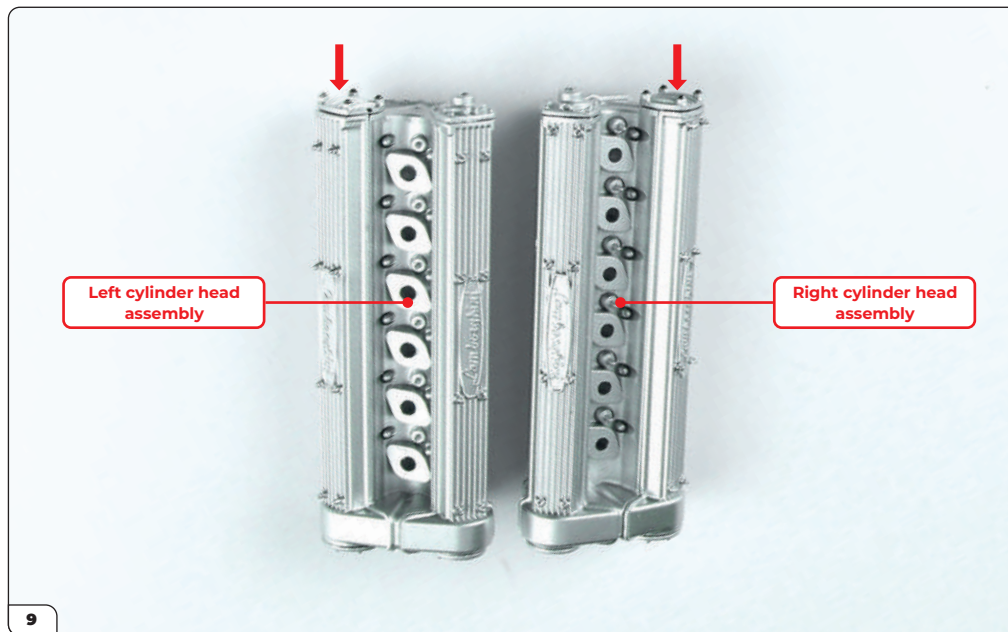

The two cylinder heads should now look like this. By placing them as shown with the side covers (arrows) furthest away from each other, you can identify the right and left cylinder head for the next stage.

STAGE COMPLETE



# Stage 10: Assembling the Right Air Filter Box and Fitting the Distributors

In this stage you'll assemble an air filter box and fit distributors onto the two cylinder heads.

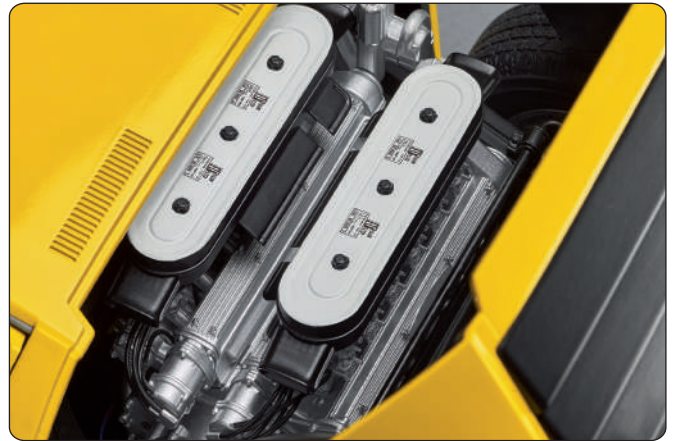

## STAGE 10 PARTS LIST

Name
Distributor (left)
Distributor (right)
Air filter box cover
Air filter box screw x3
Type A screws x3
Air filter box

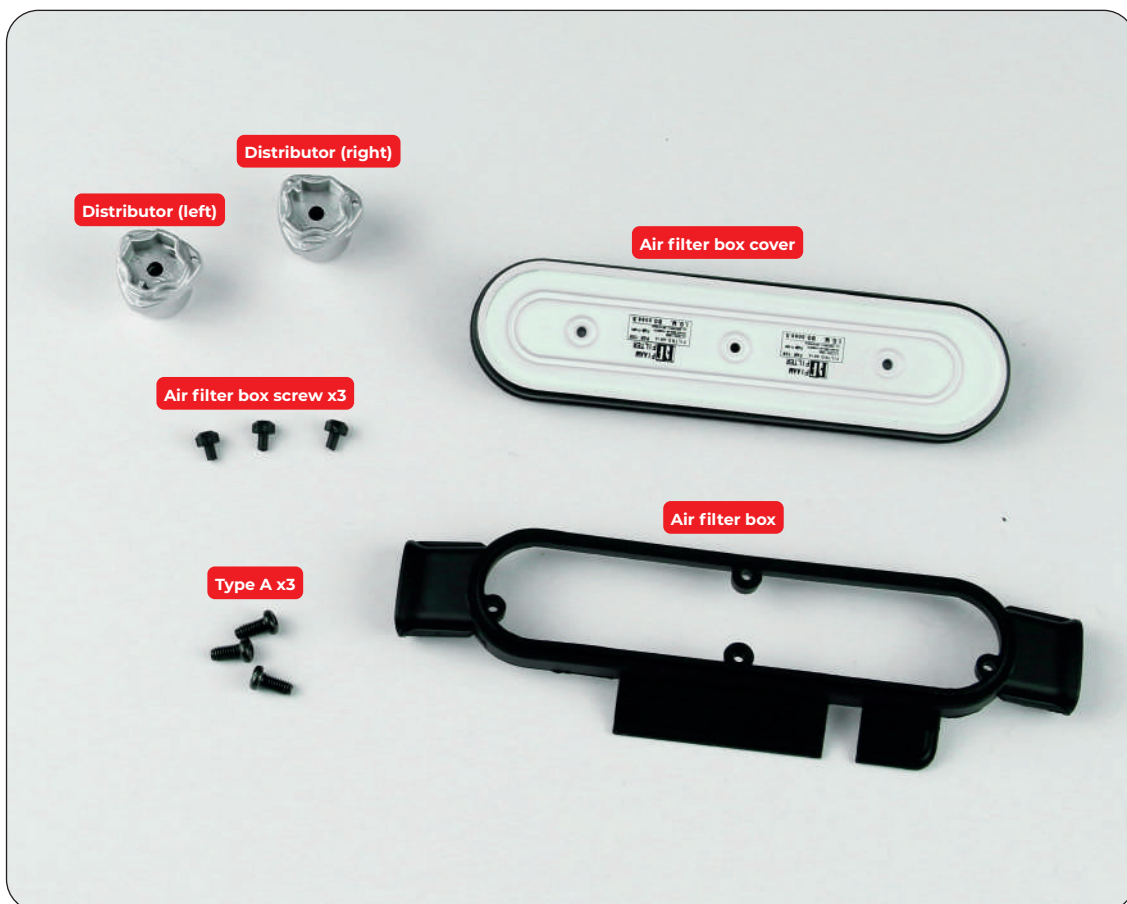



# Stage 10: Assembling the Right Air Filter Box and Fitting the Distributors

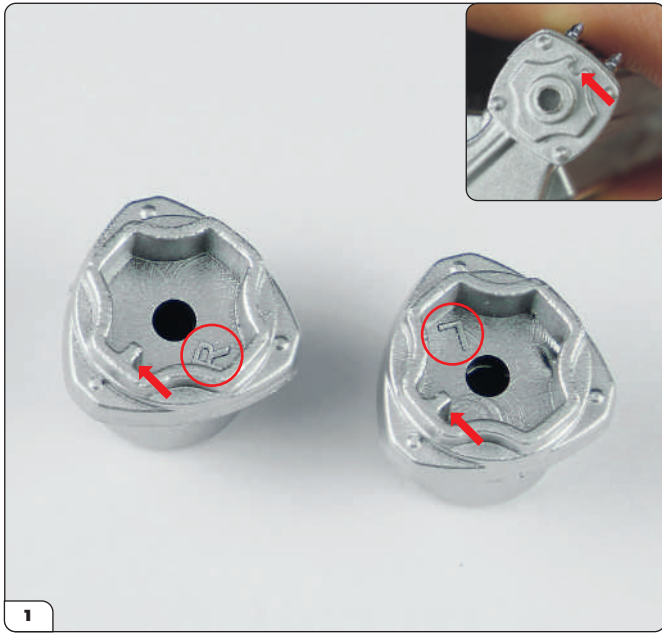

The two distributors are marked with an 'R' and an 'L' to differentiate the right from the left (circled). Note the notch (arrows) on each part that will be used to correctly align the pieces when fitting to the cylinder heads (inset, arrow).

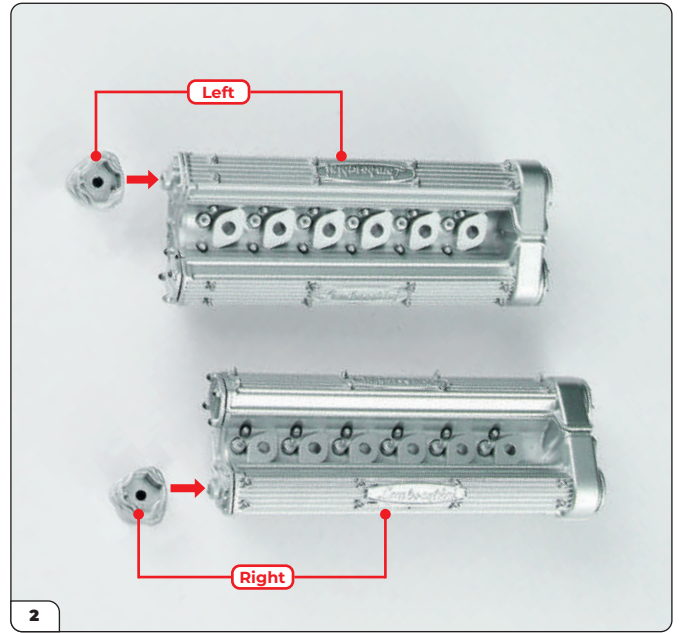

Take the two cylinder head assemblies from Stage 9 and pair them with the distributors.



Fit the right distributor (marked 'R') to the side of the right cylinder head and secure in place using 1x Type A screw.

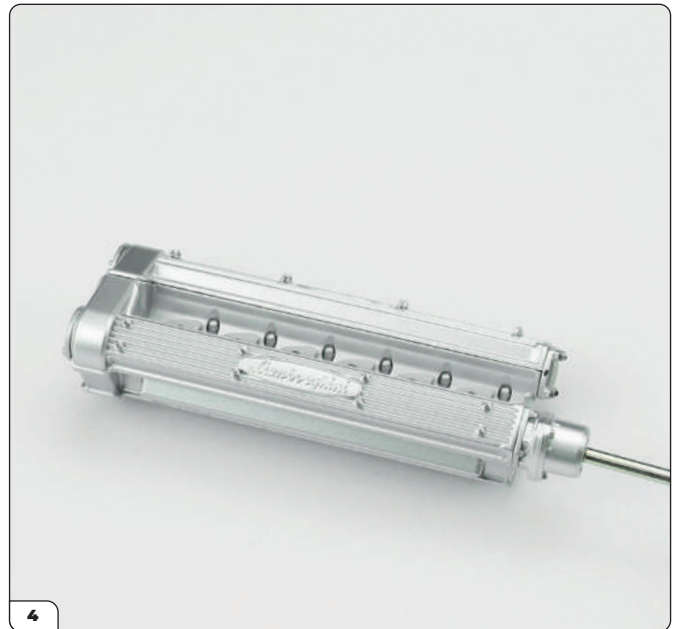

Repeat for the left distributor and the left cylinder head, fixing it in place with another Type A screw.

## Stage 10: Assembling the Right Air Filter Box and Fitting the Distributors



The two cylinder head assemblies should now look like this with the distributors attached.



Align the air filter box cover with the air filter box as shown. Note the pins and their corresponding holes (arrows).



Push the cover into the air filter box until the parts fit firmly together.



Next take the three air filter box screws and carefully push them into the holes on the cover (arrows). We recommend doing this by hand to avoid damaging the paint and print on the cover.

## Stage 10: Assembling the Right Air Filter Box and Fitting the Distributors



The air filter screws should be flush with the filter box cover once they are in place.



## Stage 11: Left Carburettor (1)

Next you'll build the first of four carburettors for this pack. Take care when fitting the inlet manifolds as their orientation changes depending on which cylinder head the carburettor will be fitted onto.



### STAGE 11 PARTS LIST

Name
Carburettor
Velocity stack x3
Inlet manifold x3
Shim plate x3
Support pin x2

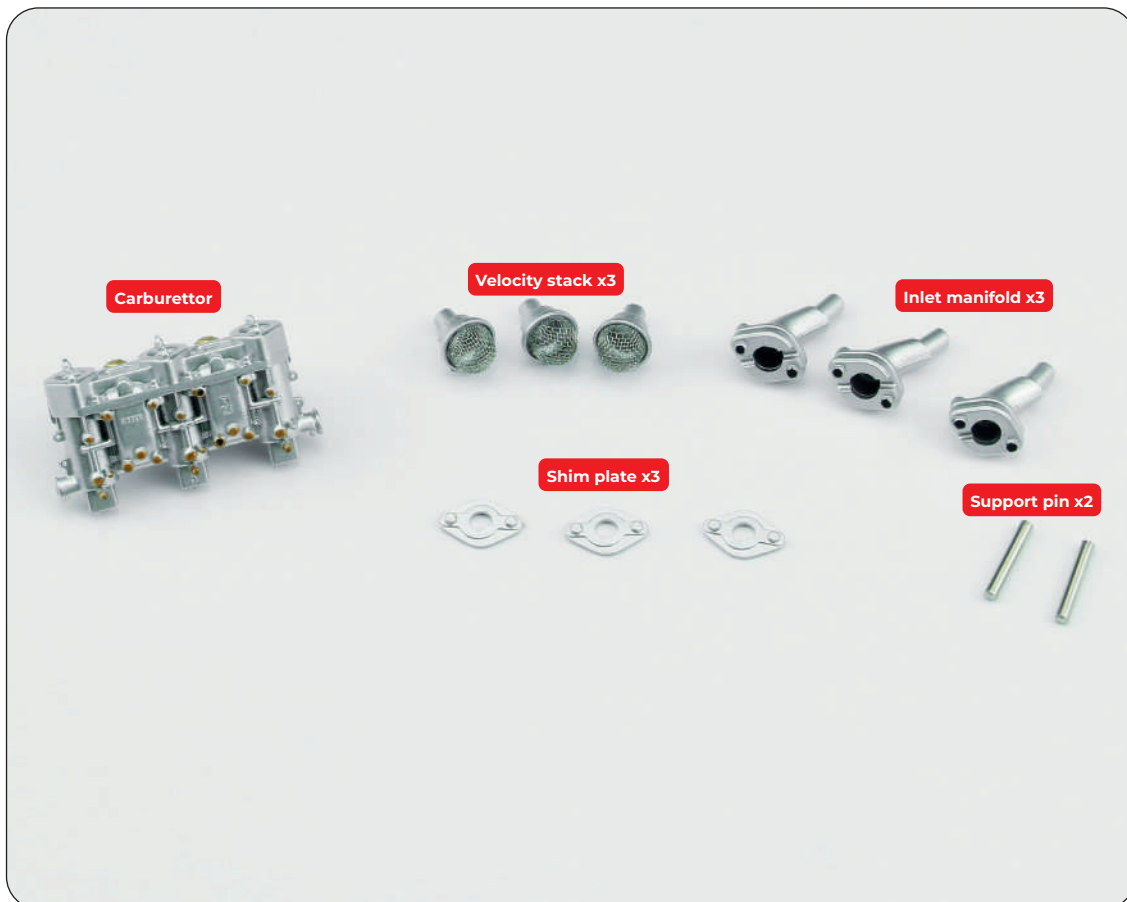

## Stage 11: Left Carburettor (1)

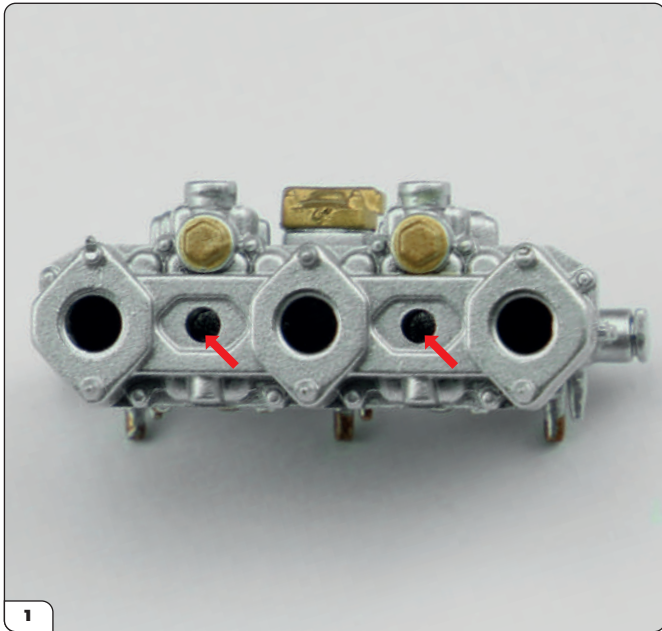

Locate the two smaller holes on the carburettor (arrows), found between the three larger holes.

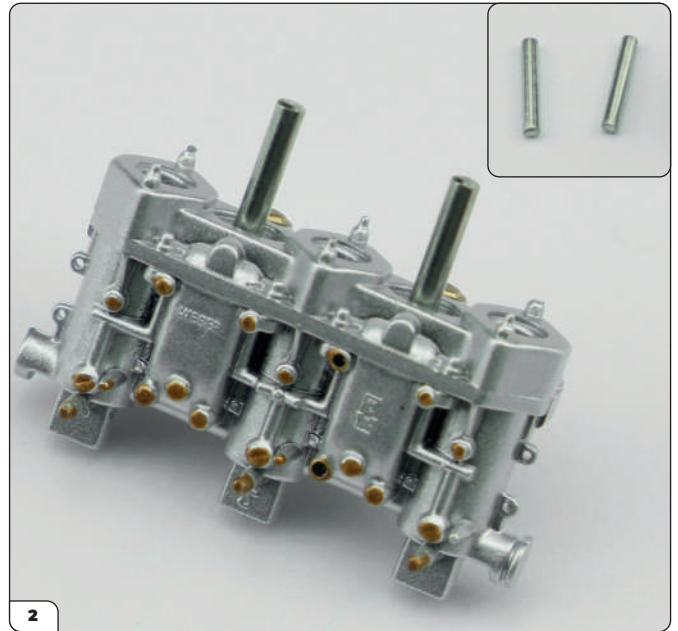

Insert the two support pins into the two smaller holes of the carburettor as shown.

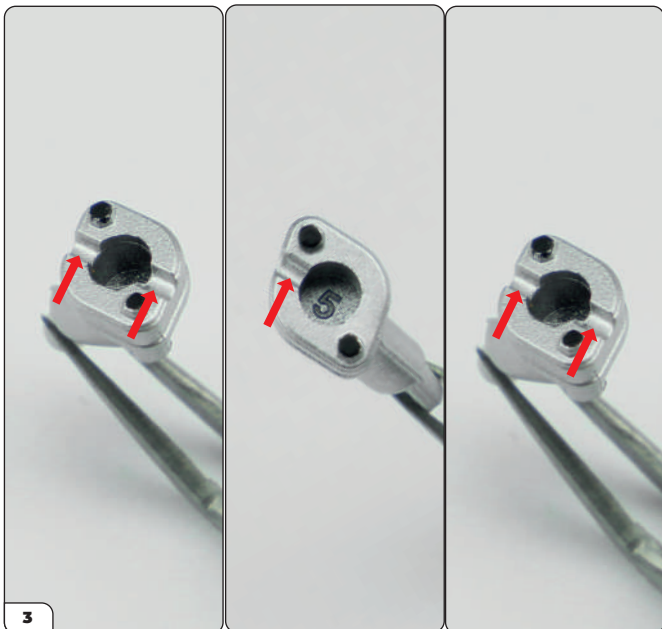

Take the three inlet manifolds. One of them has only one recess (middle photo).

The others have two recesses (outer photos): these two are interchangeable for the following step.

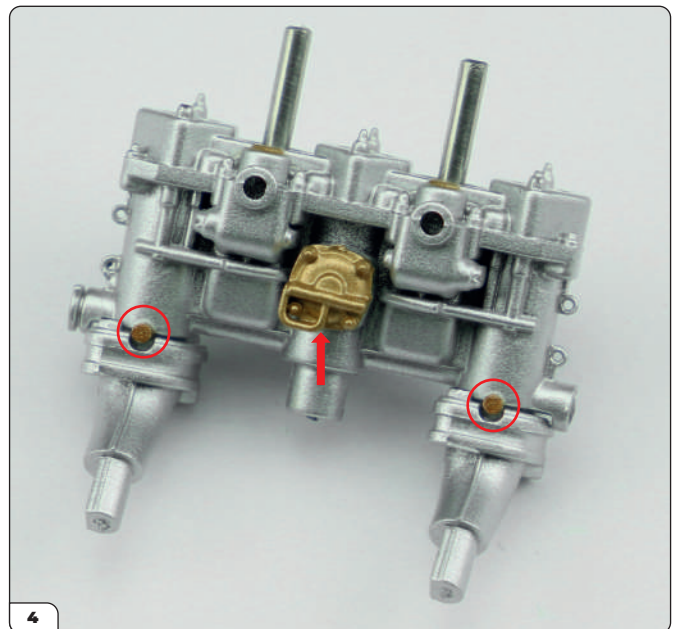

Press the manifolds with two recesses into place on the carburettor as shown, so that the golden pins of the carburettor (circled) sit in the recesses. The curve of the manifolds should lead towards the same side as the golden part (arrow).

Note: You can also check photo 10 for reference.

## Stage 11: Left Carburettor (1)

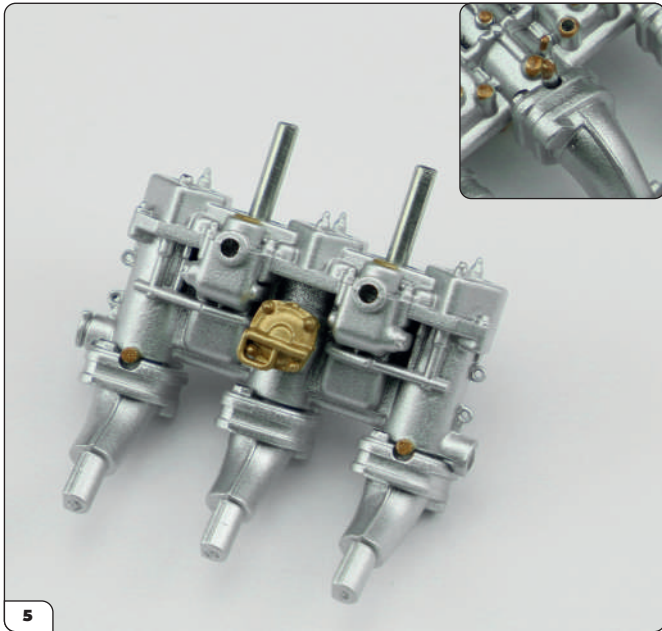

Now install the manifold with one recess by fitting it onto the middle as shown. The recess houses the protruding golden pin (inset).

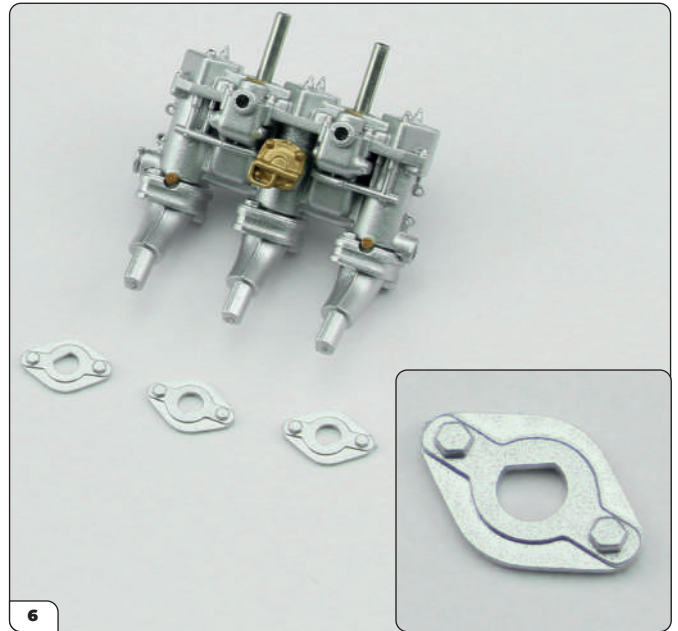

Take the three shim plates. Note the D-shaped hole (inset) that corresponds with the D-shaped pins at the end of the manifolds.

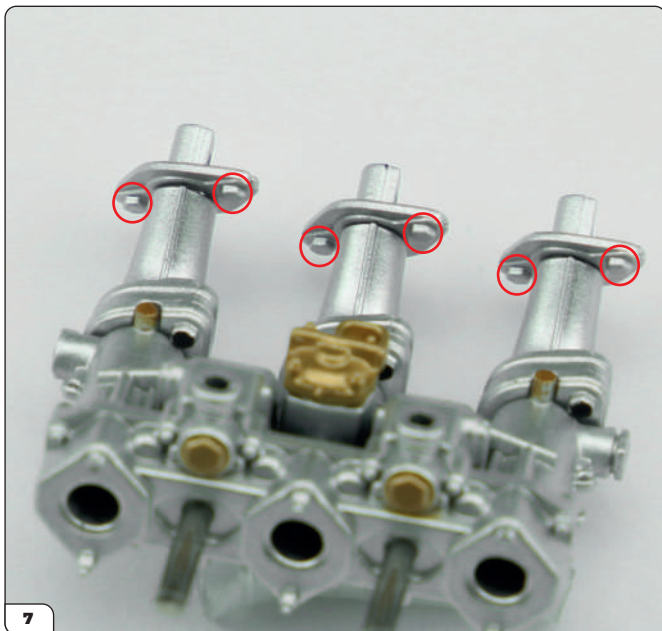

Fit the three shims onto the ends of the manifolds so that the nuts (circled) face towards the carburettor as shown.



Next push one of the velocity stacks into a larger hole in the carburettor. **Take care to hold the stack by the outer edge and not the grill to avoid damaging the part.**

Tip: Rotating the stack as you insert it helps with fitting it in place.

## Stage 11: Left Carburettor (1)



Push the other two stacks into the remaining large holes.

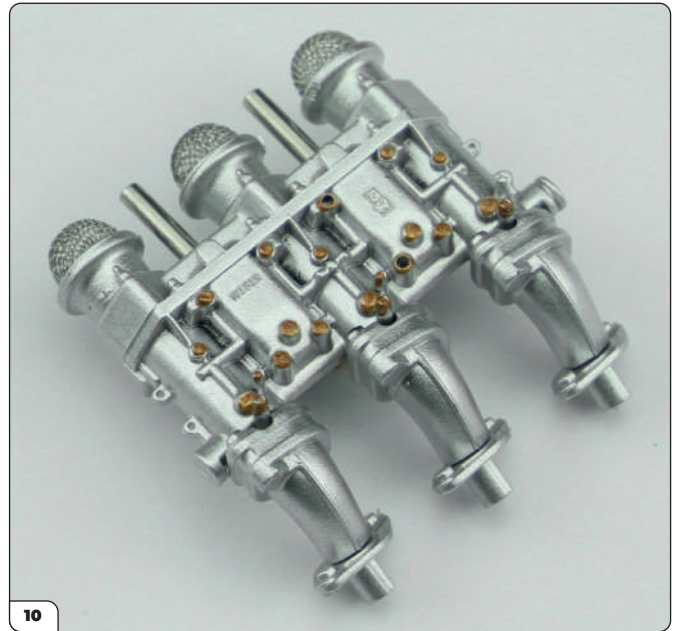

The carburettor should look like this with all parts in place. Note the curvature of the inlet manifolds.

**STAGE COMPLETE**



## Stage 12: Left Carburettor (2)

In this stage you'll assemble the second carburettor, in the same manner as you did before. The inlet manifolds for this stage are mounted in the same direction as the previous ones.

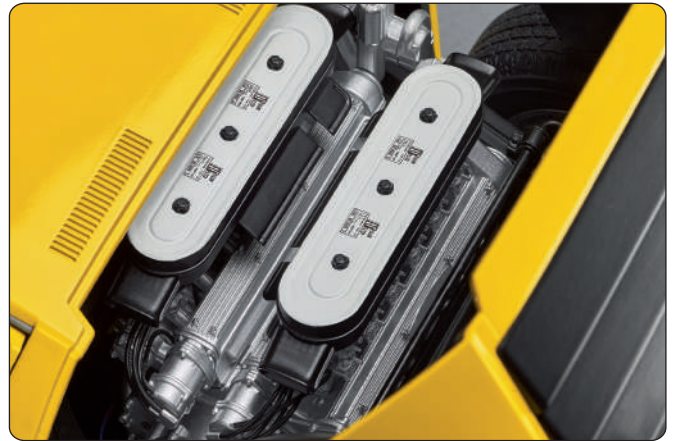

### STAGE 12 PARTS LIST

Name
Inlet manifold x3
Carburettor
Velocity stack x3
Support pin x2
Shim plate x3

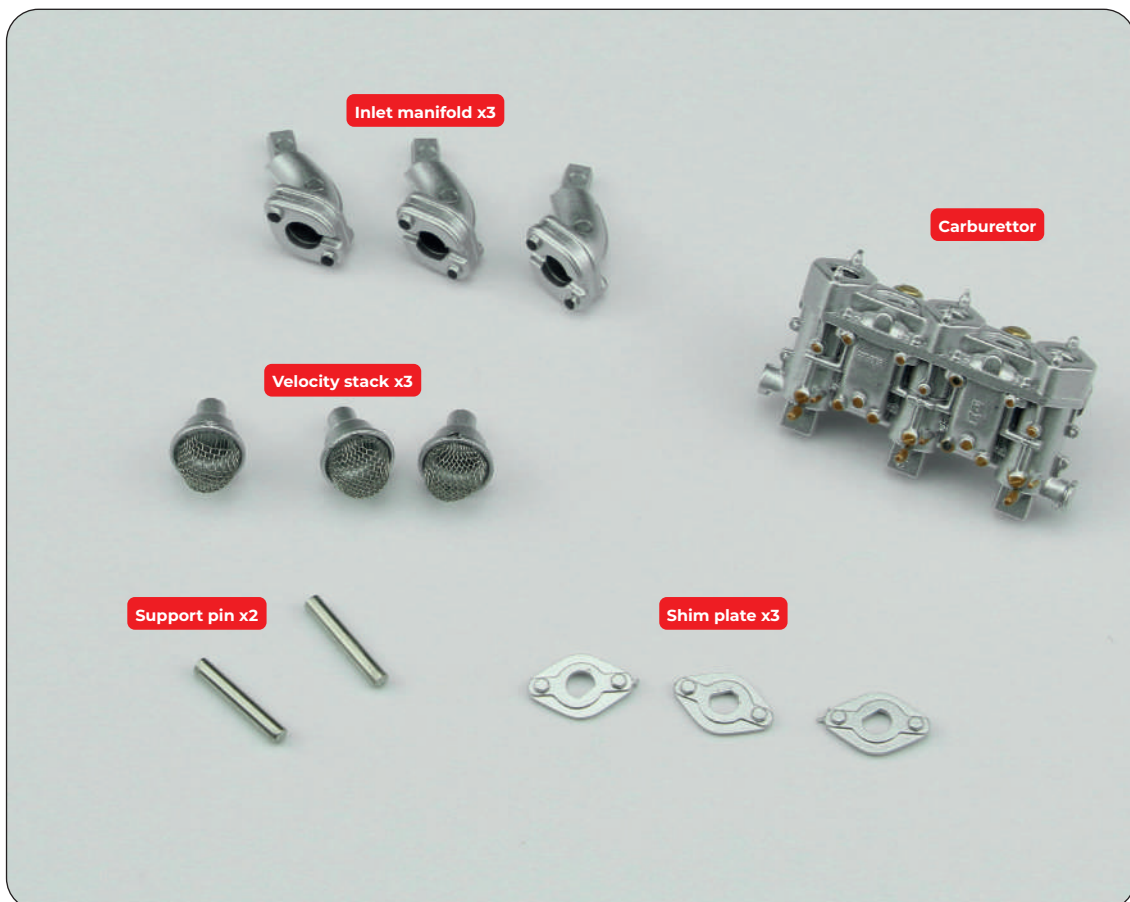



## Stage 12: Left Carburettor (2)

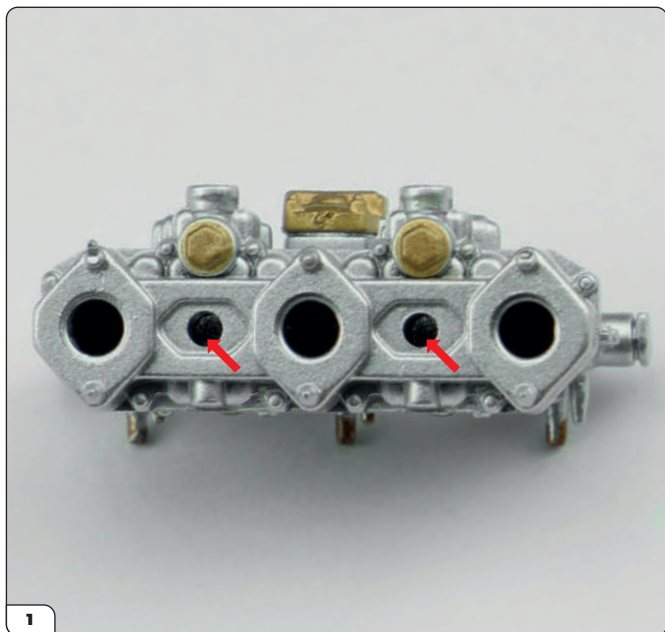

Locate the two smaller holes on the carburettor (arrows), found between the three larger holes.

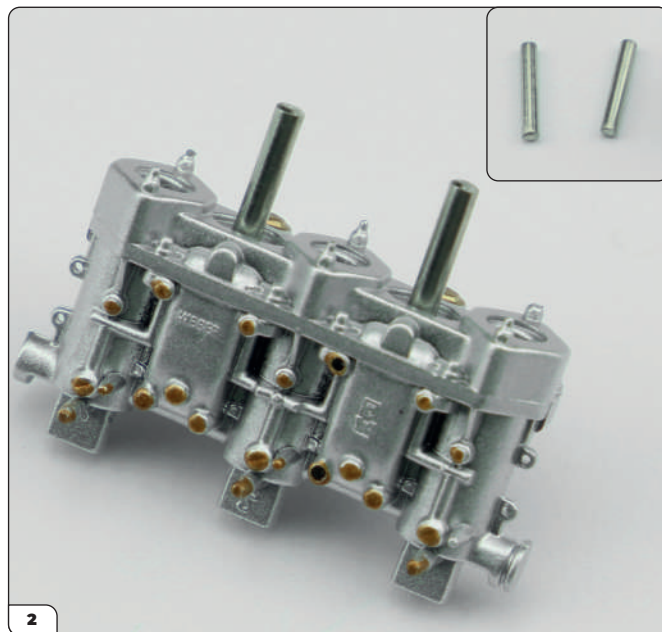

Insert the two support pins into the two smaller holes of the carburettor as shown.

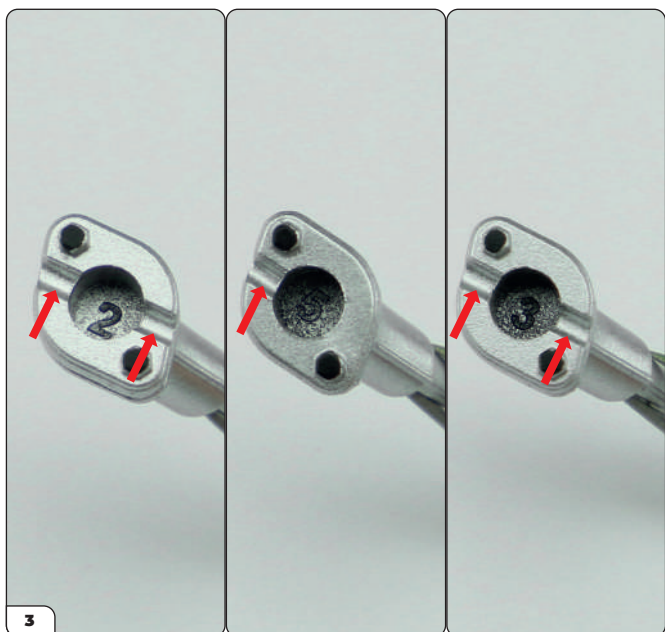

Take the three inlet manifolds. One of them has only one recess (middle photo).

The others have two recesses (outer photos): these are interchangeable for the following step.

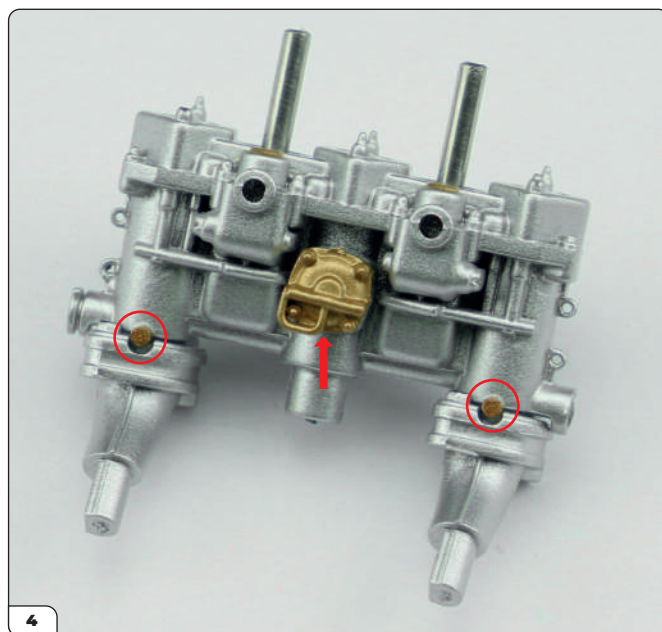

Press the manifolds with two recesses into place on the carburettor as shown, so that the golden pins of the carburettor (circled) sit in the recesses. The curve of the manifolds should lead towards the same side as the golden part (arrow).

## Stage 12: Left Carburettor (2)

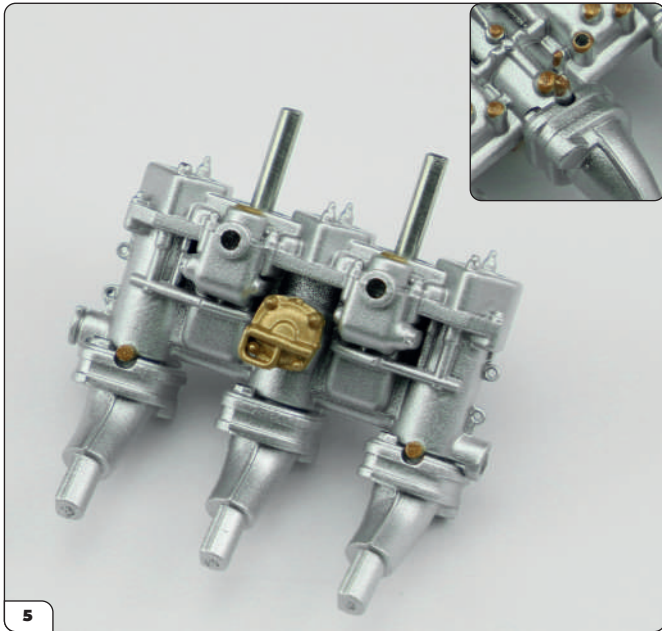

Now install the manifold with one recess by fitting it onto the middle as shown. The recess houses the protruding golden pin (inset).

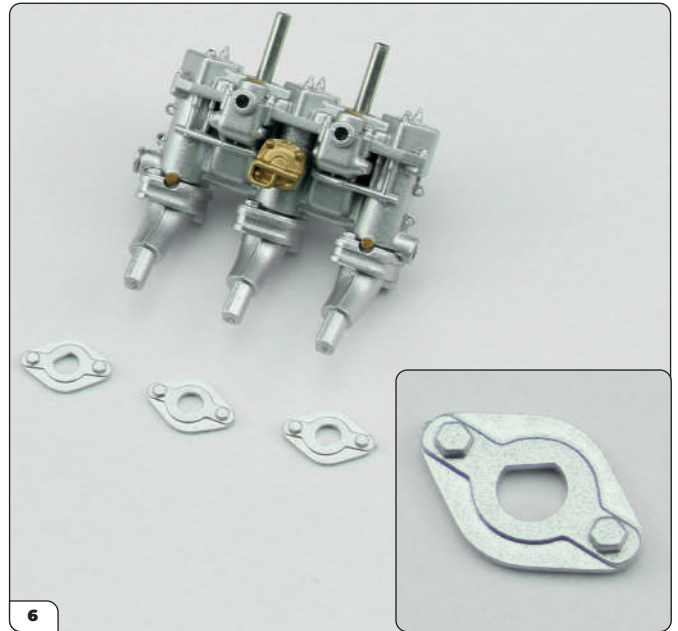

Take the three shim plates. Note the D-shaped hole (inset) that corresponds with the D-shaped pins at the end of the manifolds.

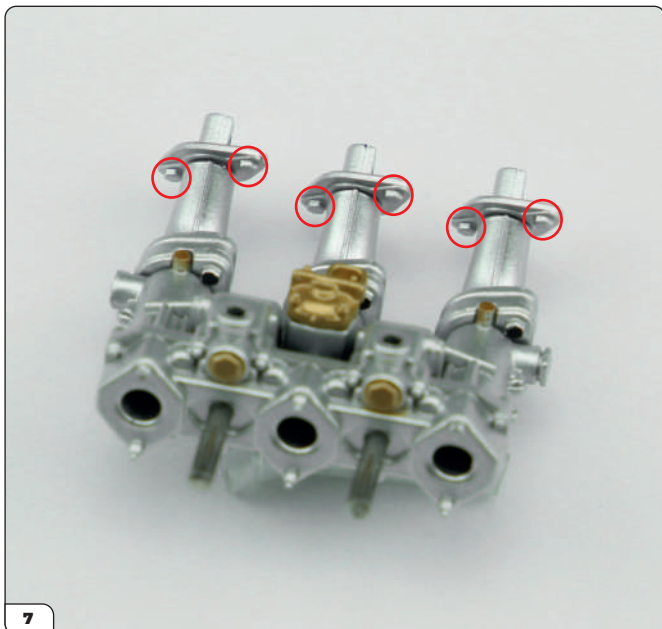

Fit the three shims onto the ends of the manifolds so that the nuts (circled) face towards the carburettor as shown.

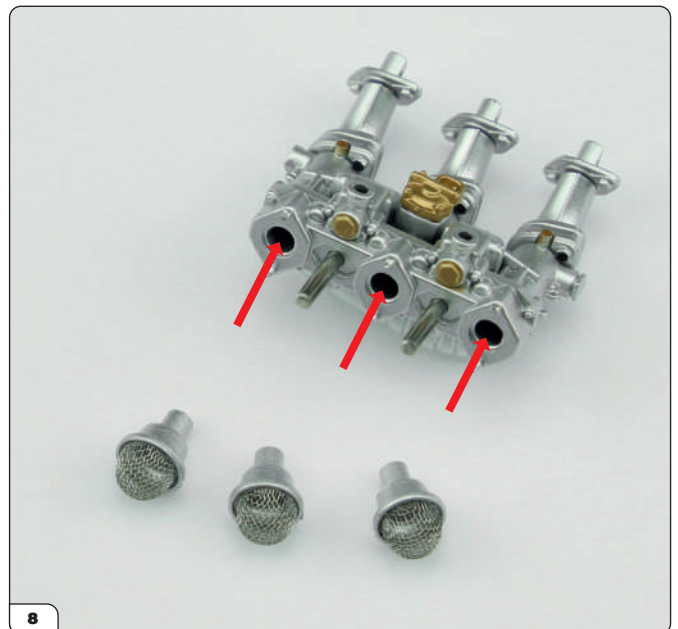

Next push the three velocity stacks into the larger holes in the carburettor (arrows). **Take care to hold the stacks by the outer edge and not the grill to avoid damaging the part.**

Tip: Rotating the stacks as you insert them helps with fitting in place.

# Stage 12: Left Carburettor (2)



## Stage 13: Attaching the Spark Plug Cables

This stage returns to the cylinder heads, where you'll fit caps onto the distributors and then connect the spark plugs up with their cables.

You can fit the spark plug cables to both cylinder heads at the same time if preferred.

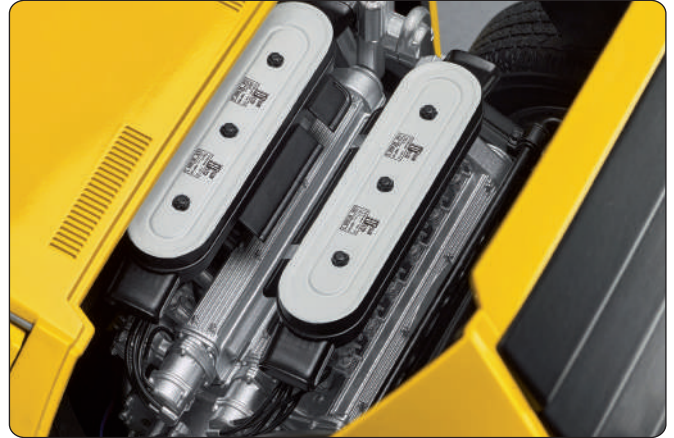

### STAGE 13 PARTS LIST

Name
Distributor cap x2
Distributor cap attachment x2
Spark plug A cable x2
Spark plug B cable x2
Spark plug C cable x2
Spark plug D cable x2
Spark plug E cable x2
Spark plug F cable x2

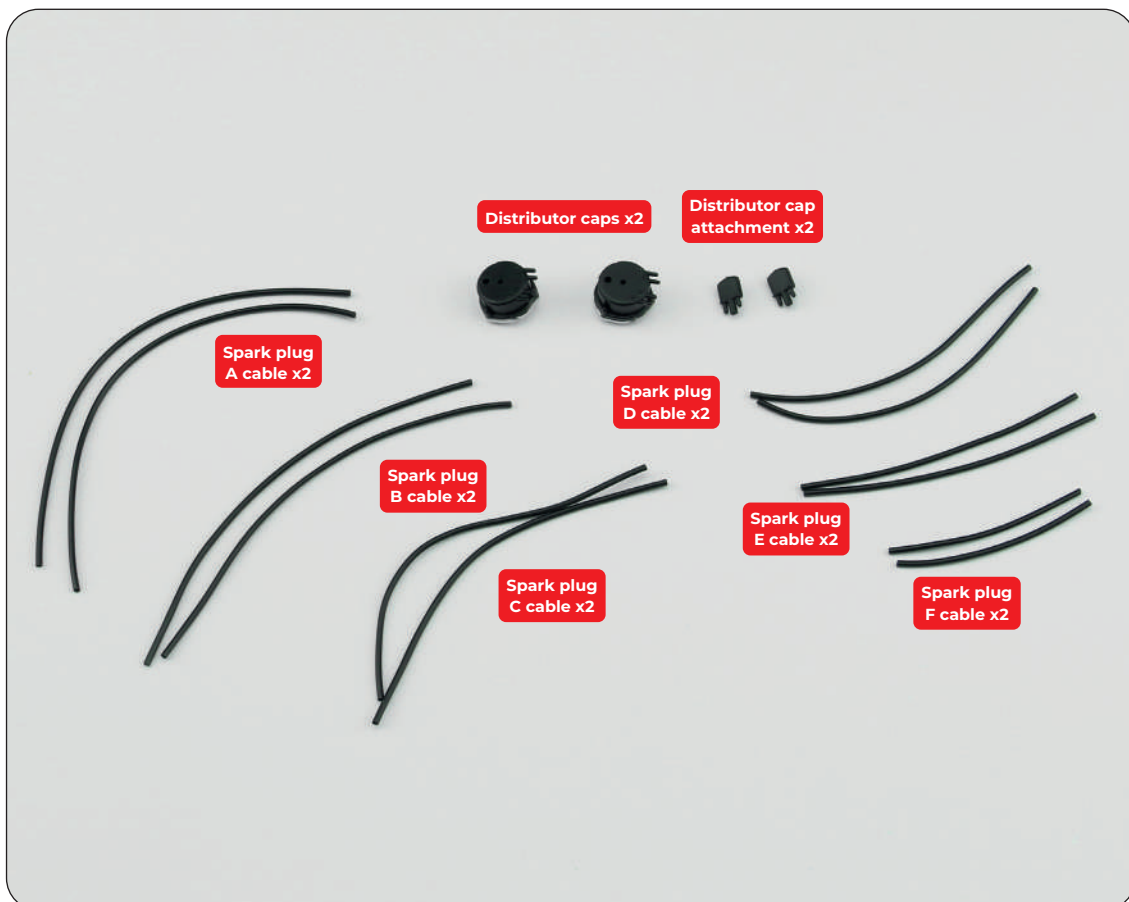

## Stage 13: Attaching the Spark Plug Cables



Take the left cylinder head assembly from Stage 10 and one of the distributor caps supplied with this stage.

Note: the following steps are repeated for the right cylinder head. You can assemble both simultaneously if preferred.

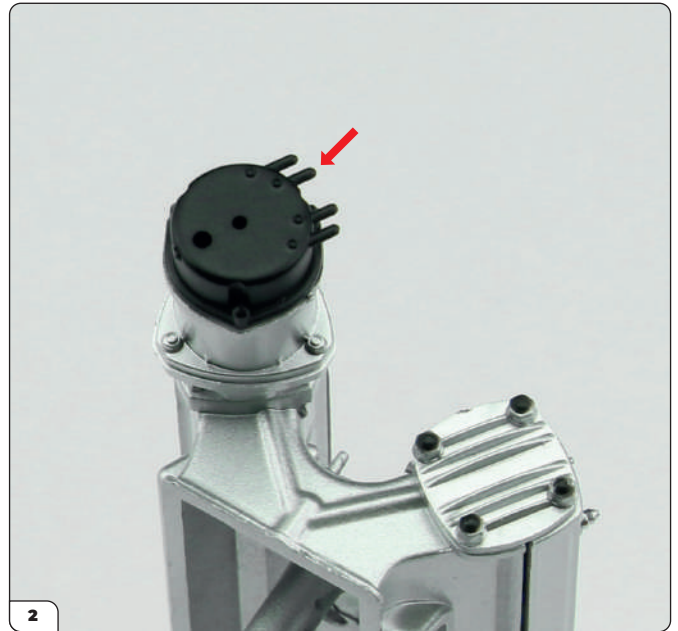

Press the two pins on the rear of the distributor cap into the holes of the distributor. The spark plug cable connectors (arrow) should be oriented in the direction pictured.

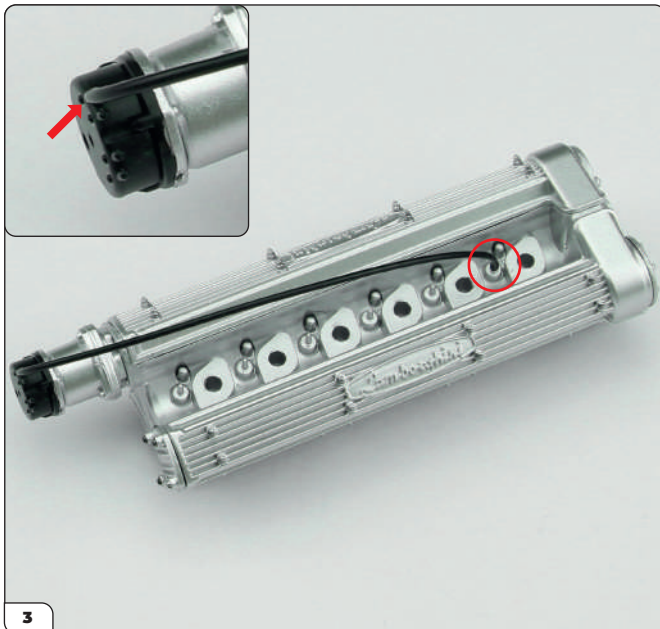

Next take one of the spark plug A cables and push the end onto the topmost cable connector on the distributor cap (inset) and the furthest spark plug (circled).



Now fit one of the B cables onto the cable connector adjacent to the previous one (inset). Push the other end of the cable into the next spark plug (circled).

## Stage 13: Attaching the Spark Plug Cables



Fit one of the C cables into the next connector and spark plug in sequence (arrows).

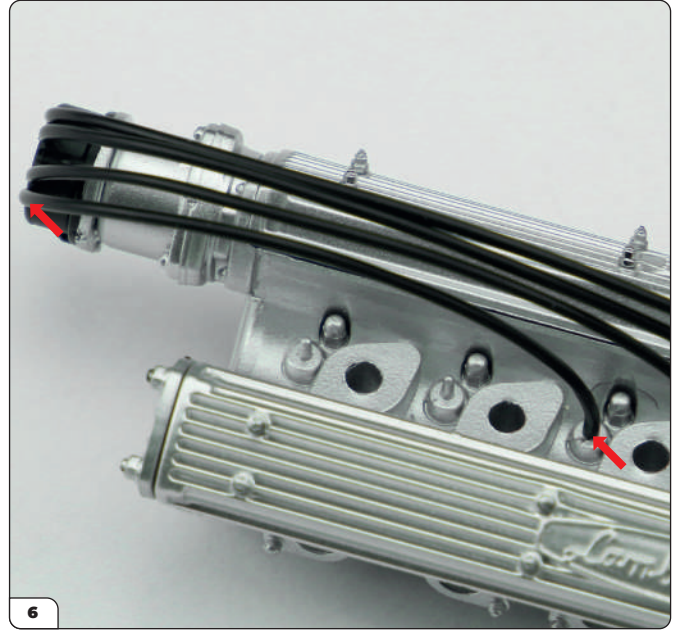

Then take one of the D cables and fit onto the indicated connector and spark plug (arrows).

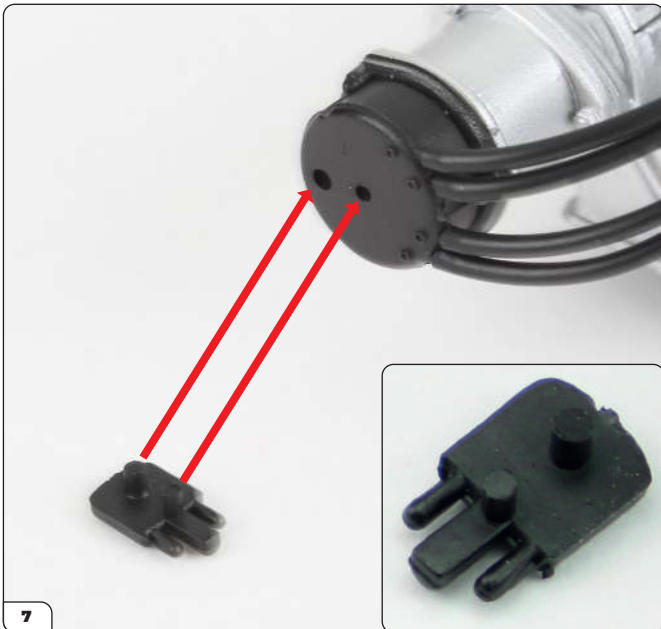

Align one of the distributor cap attachments with the cap as shown. Note the two pins on the attachment (inset), with one larger pin and one smaller pin.



Fit the attachment in place, so that the two pins fit into the corresponding holes on the distributor cap.

## Stage 13: Attaching the Spark Plug Cables

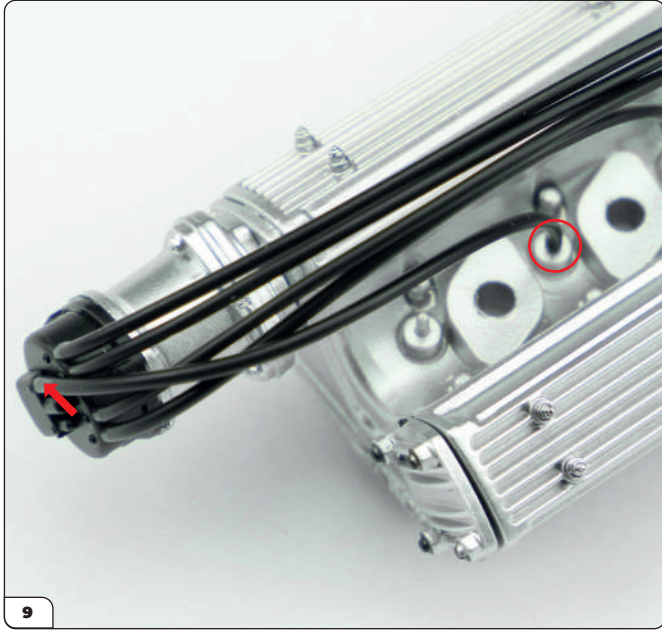

Take one of the E cables and fit it to the topmost connector on the attachment (arrow) and the furthest spark plug (circled).

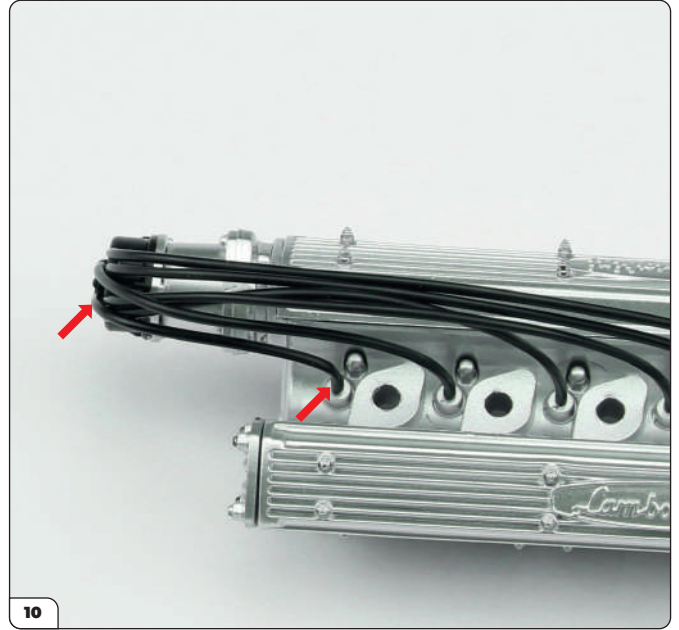

Finally, take one of the F cables and attach it to the remaining connector and spark plug (arrows).

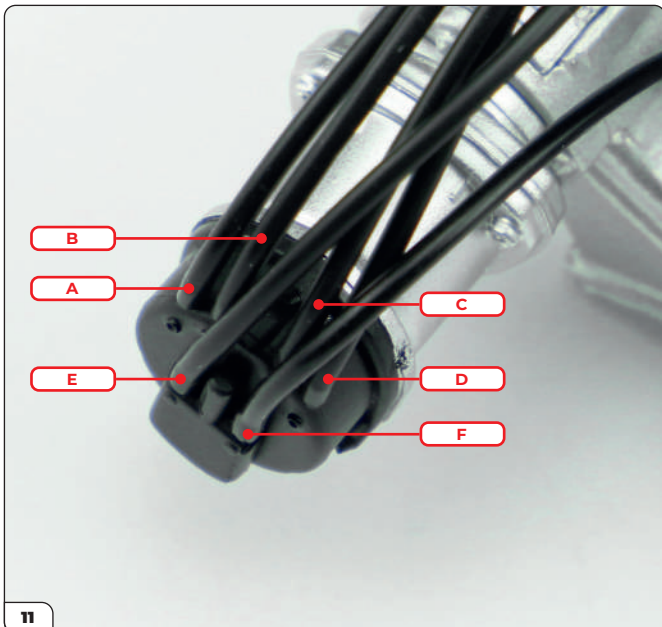

The cables should now be fitted onto the distributor cap as shown.



Repeat steps 2 to 10 for the right cylinder head from Stage 10. The two cylinder heads should look like this once finished.

## Stage 13: Attaching the Spark Plug Cables

---

STAGE COMPLETE





## Stage 14: Right Carburettor (1)

You'll now build the third carburettor, with the inlet manifolds mounted in the opposite direction to the previous ones, before installing it onto the right cylinder head at the end of this stage.

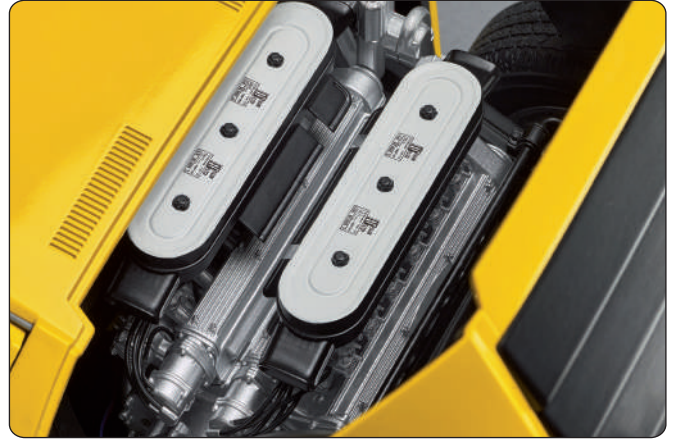

### STAGE 14 PARTS LIST

Name
Shim plate x3
Support pin x2
Carburettor
Velocity stack x3
Inlet manifold x3

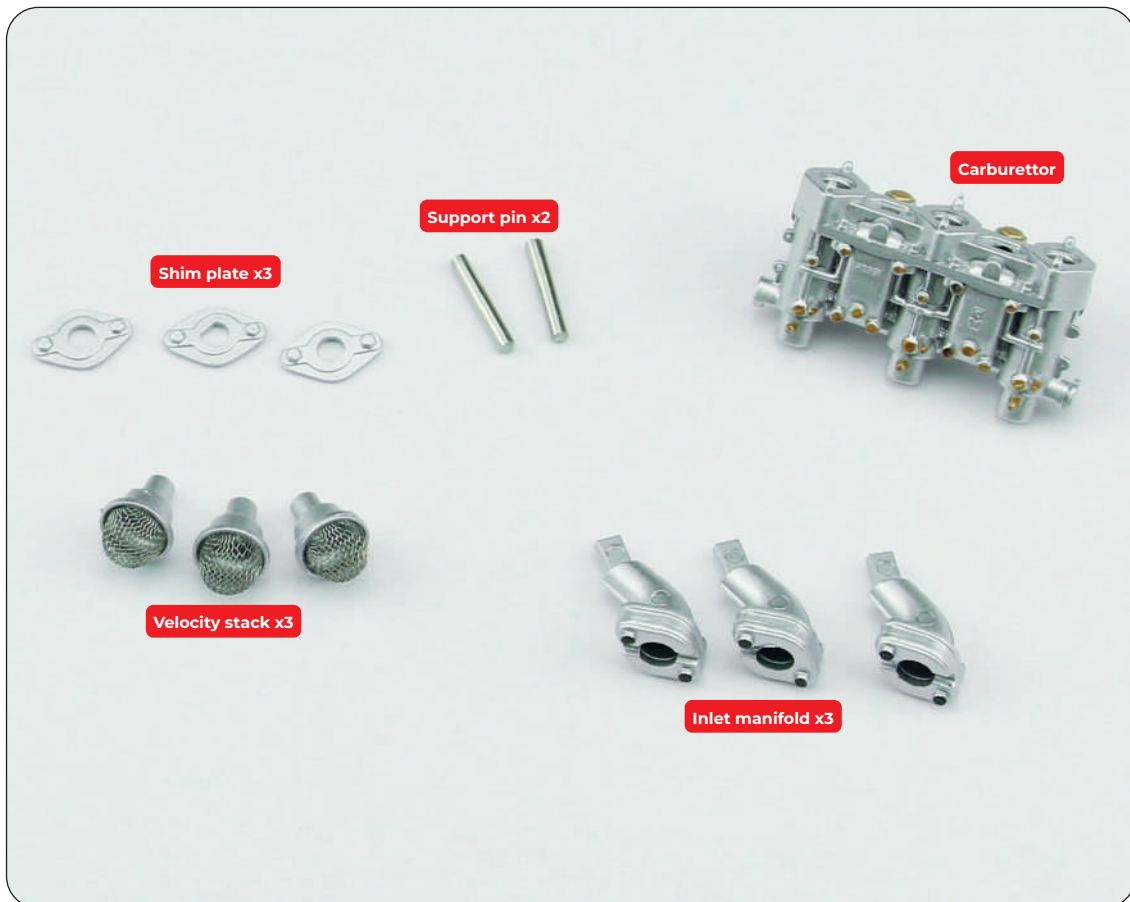

## Stage 14: Right Carburettor (1)

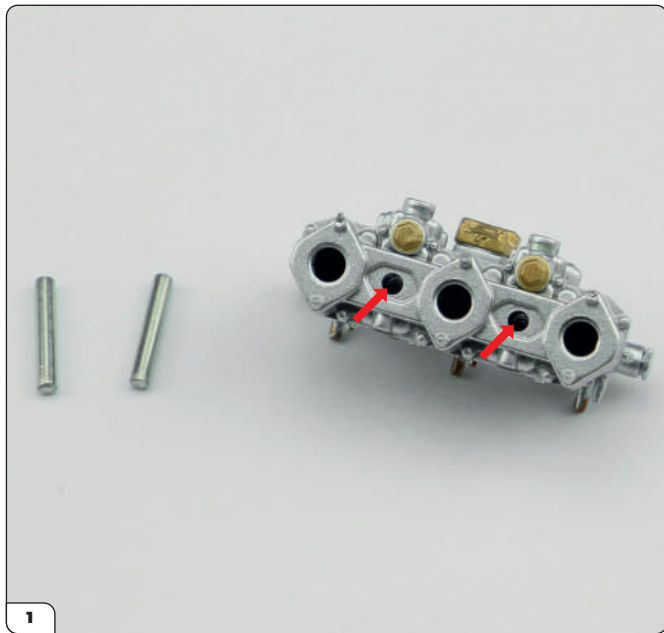

Take the support pins and locate the two smaller holes on the carburettor (arrows).

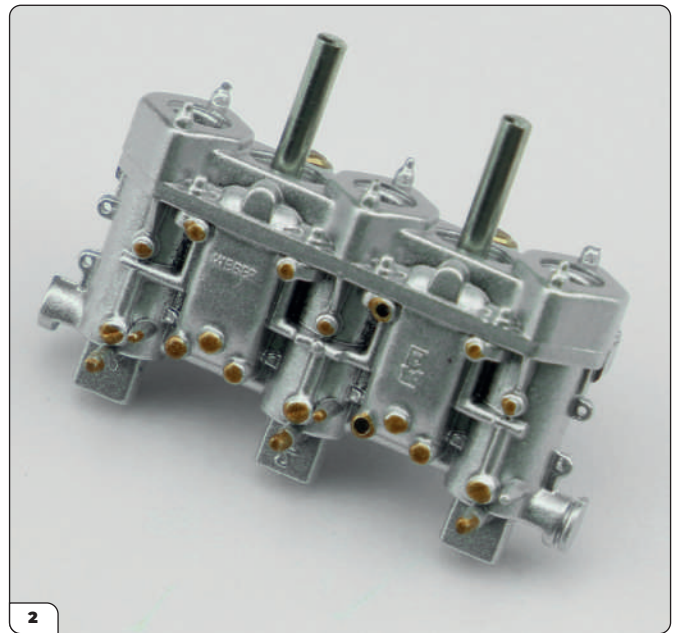

Fully insert the support pins into the two smaller holes of the carburettor as shown.

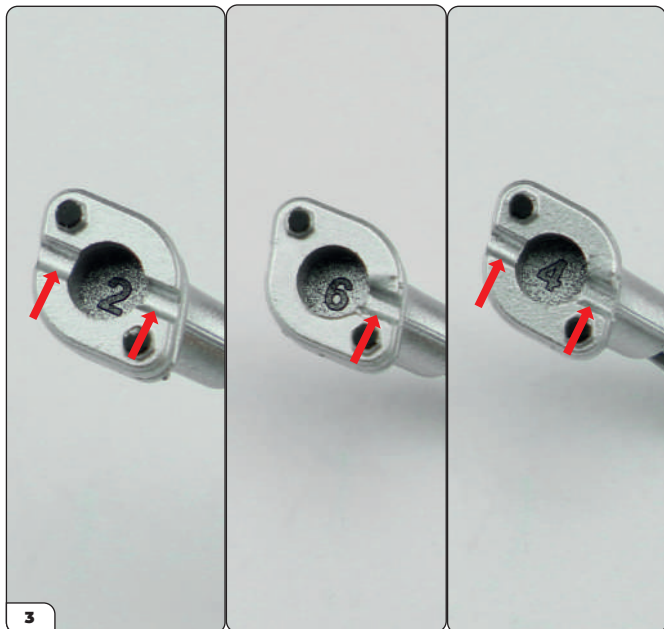

Take the three inlet manifolds. One of them has only one recess (middle photo).

The others have two recesses (outer photos): these two are interchangeable for the following step.

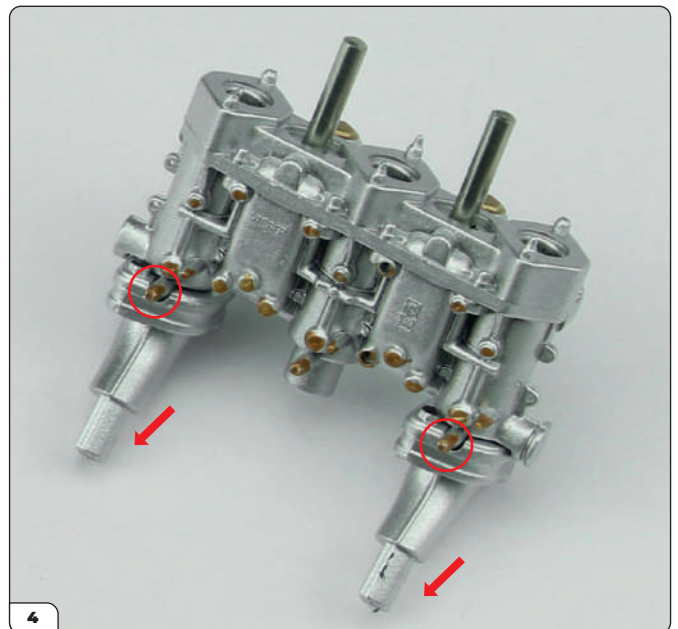

Press the manifolds with two recesses into place, so that the golden pins of the carburettor (circled) sit in the recesses. **The curve of the manifolds should lead in the opposite direction to the previous ones assembled in this pack (arrows).**

## Stage 14: Right Carburettor (1)

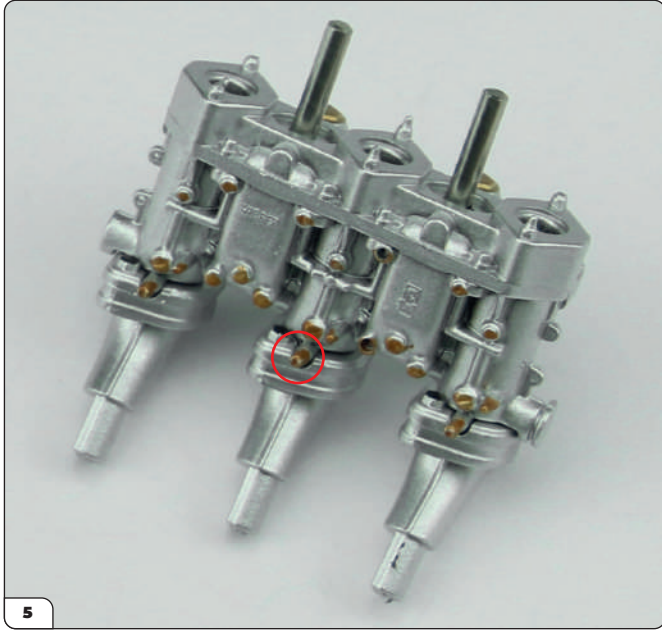

Now install the manifold with one recess by fitting it onto the middle as shown. The recess houses the protruding golden pin (circled).

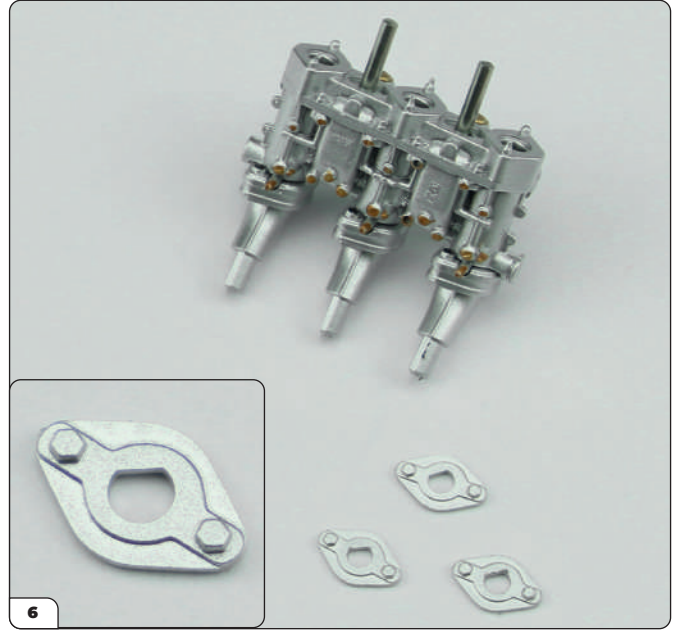

Take the three shim plates. Note the D-shaped hole (inset) that corresponds with the D-shaped pins at the end of the manifolds.

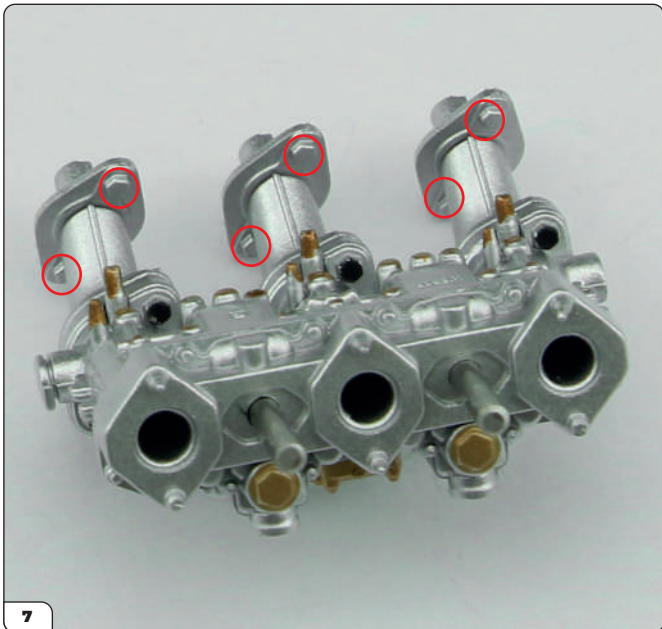

Fit the three shims onto the ends of the manifolds so that the nuts (circled) face towards the carburettor as shown.



Next push the velocity stacks into the larger holes in the carburettor, as you did before. **Take care to hold the stacks by the outer edge and not the grill to avoid damaging the part.**

Tip: Rotating the stacks as you insert them helps with fitting in place.

## Stage 14: Right Carburettor (1)



Now take the right cylinder head assembly from the previous stage and align it with the cylinder head as shown so that the three pins from the manifolds can be inserted into the corresponding holes in the cylinder head.

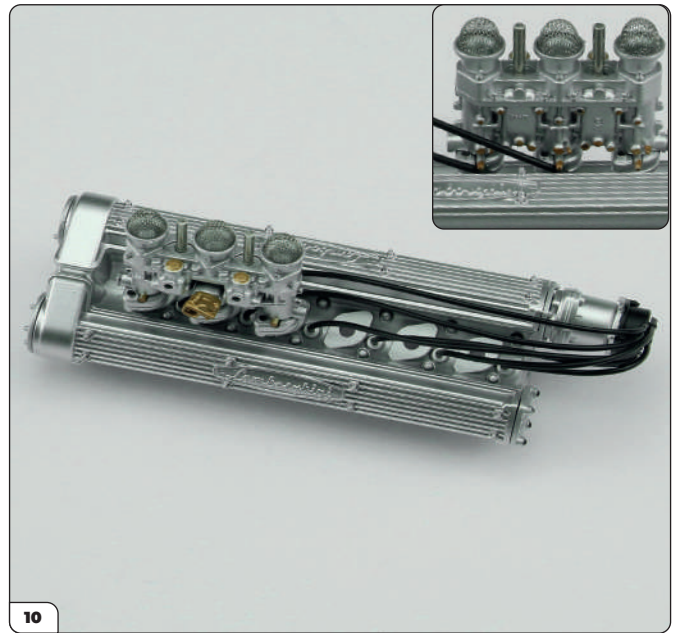

Carefully fit the carburettor into the cylinder head ensuring that the pins are pressed into the holes simultaneously. Note the spark plug cables should lead behind the carburettor (inset).

**STAGE COMPLETE**



## Stage 15: Right Carburettor (2)

In the final stage for this pack, you'll assemble the fourth carburettor and install it next to the previous one on the right cylinder head.

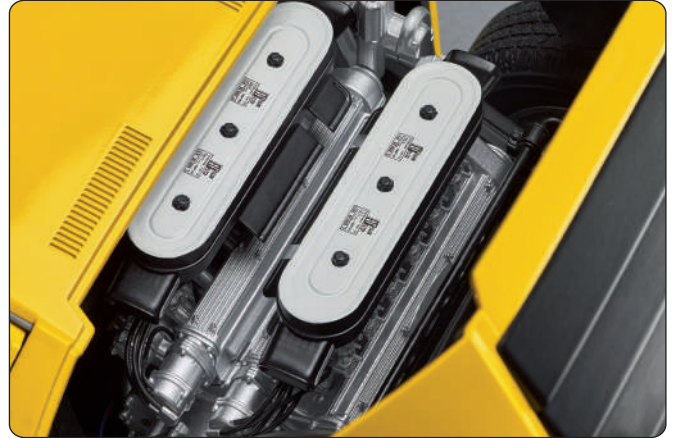

### STAGE 15 PARTS LIST

Name
Support pin x2
Carburettor
Velocity stack x3
Inlet manifold x3
Shim plate x3

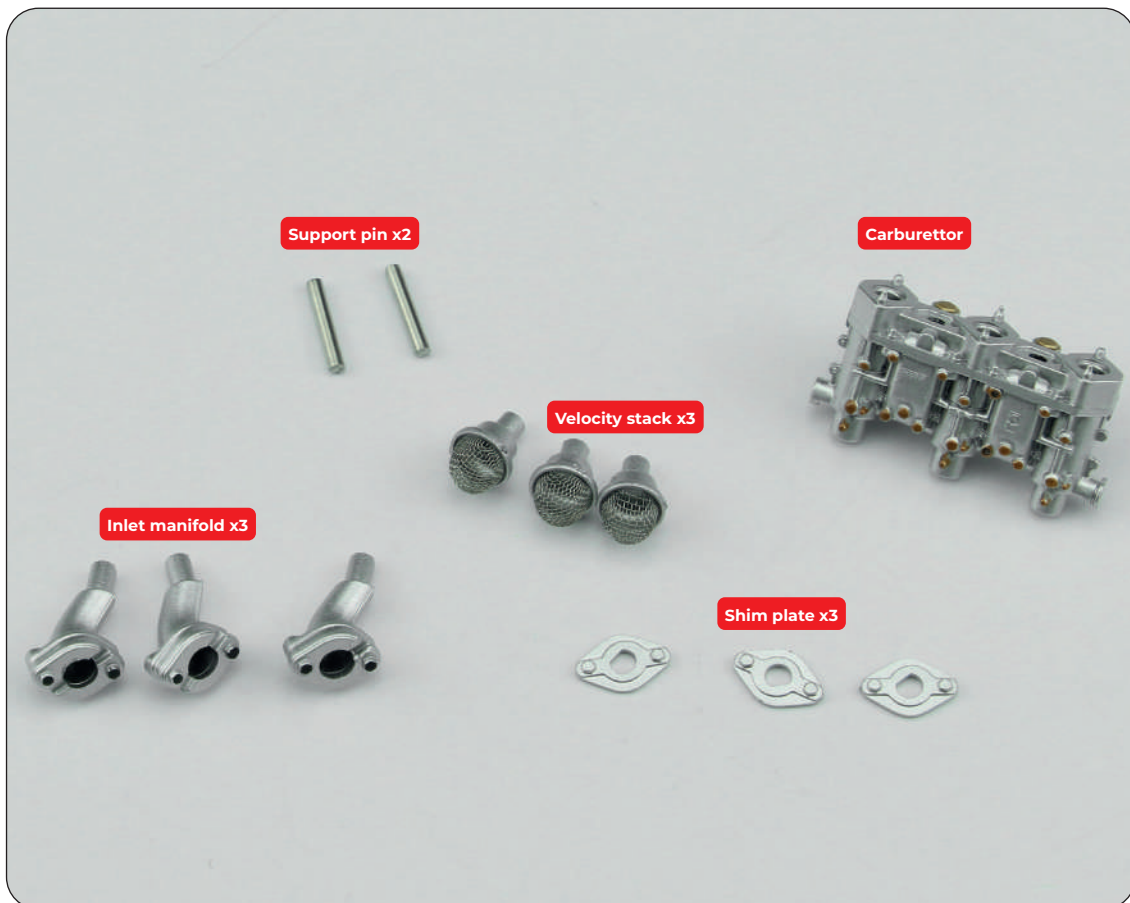

## Stage 15: Right Carburettor (2)

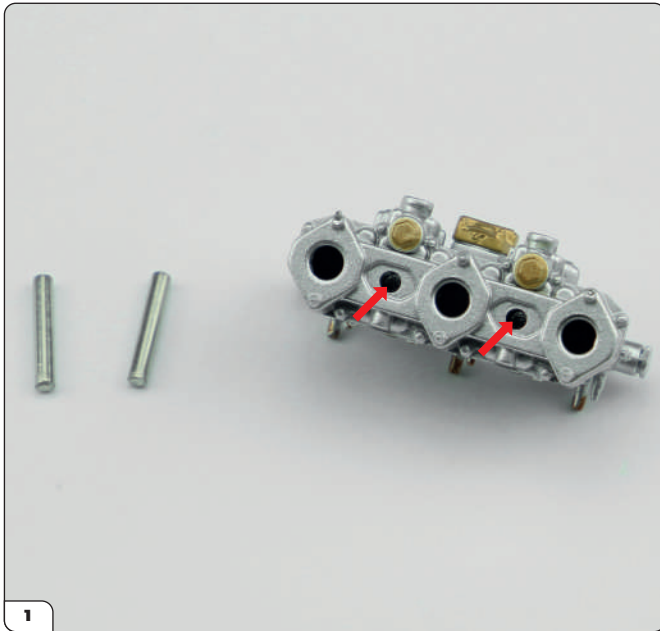

Take the support pins and locate the two smaller holes on the carburettor (arrows), found between the three larger holes.

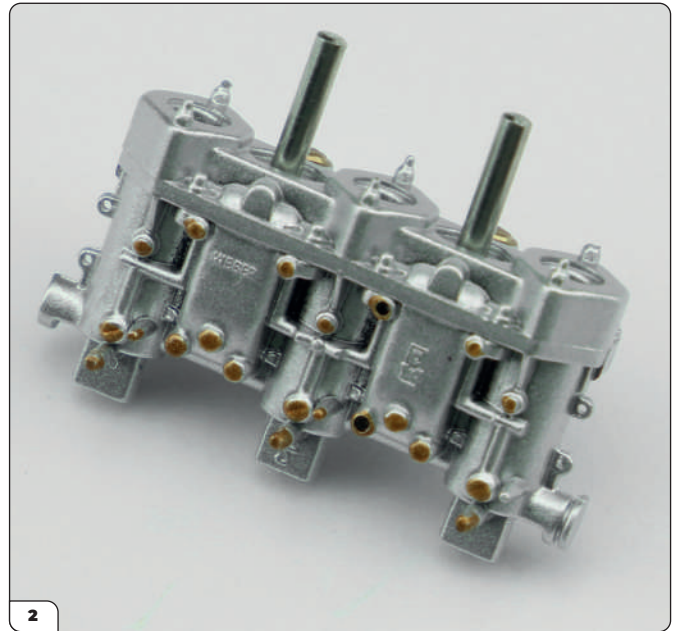

Fully insert the support pins into the two smaller holes of the carburettor as shown.

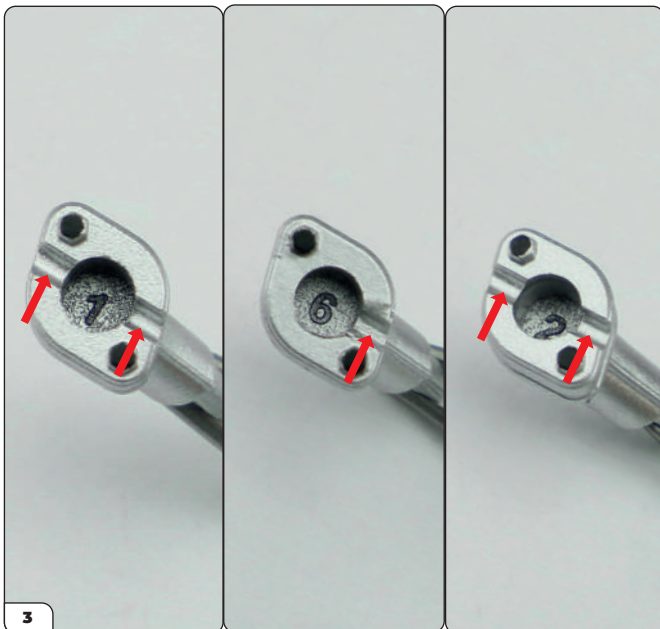

Take the three inlet manifolds. One of them has only one recess (middle photo).

The others have two recesses (outer photos): these two are interchangeable for the following step.

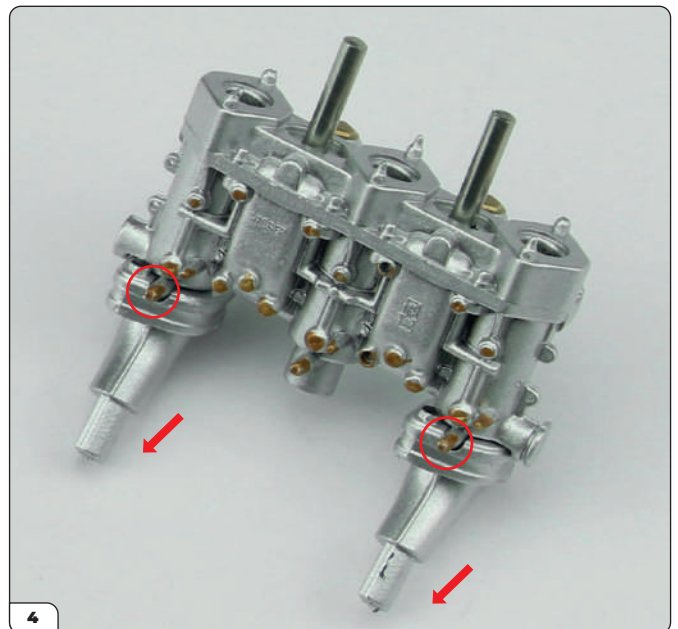

Press the manifolds with two recesses into place, so that the golden pins of the carburettor (circled) sit in the recesses. The curve of the manifolds should lead in the same direction as the previous stage (arrows).

## Stage 15: Right Carburettor (2)

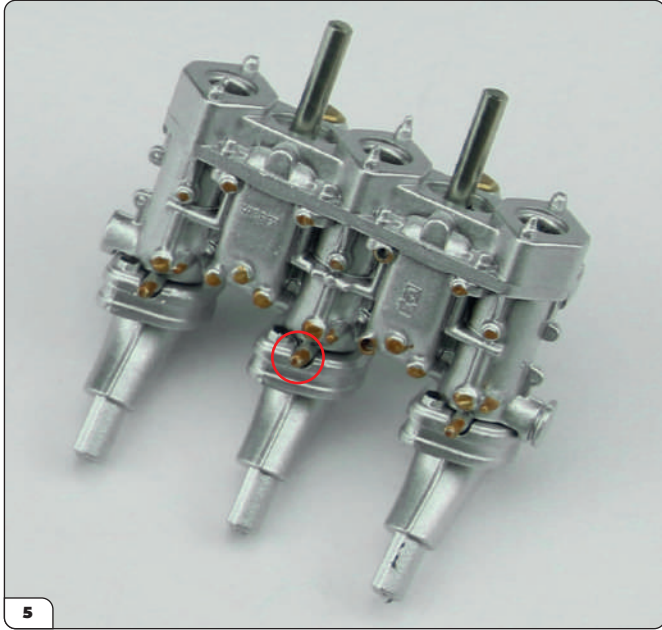

Now install the manifold with one recess by fitting it onto the middle as shown. The recess houses the protruding golden pin (circled).

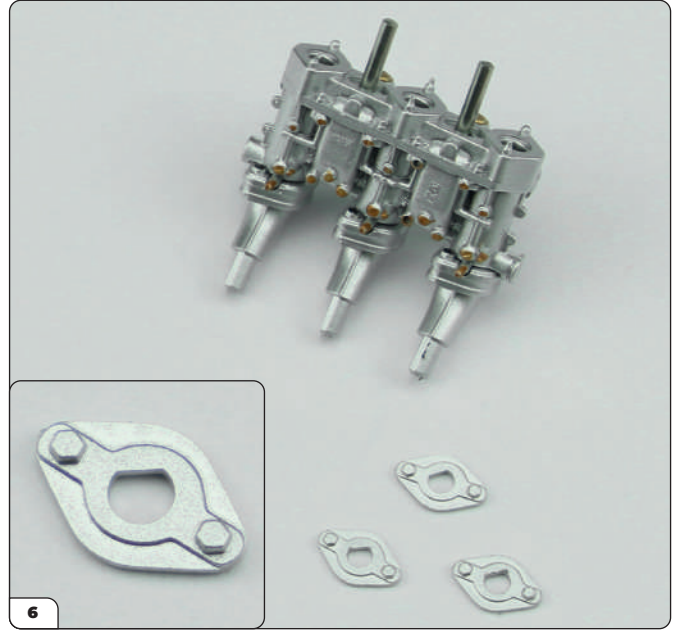

Take the three shim plates. Note the D-shaped hole (inset) that corresponds with the D-shaped pins at the end of the manifolds.



Fit the three shims onto the ends of the manifolds so that the nuts (circled) face towards the carburettor as shown.



Next push the velocity stacks into the larger holes in the carburettor, as you did before. **Take care to hold the stacks by the outer edge and not the grill to avoid damaging the part.**

Tip: Rotating the stacks as you insert them helps with fitting in place.

## Stage 15: Right Carburettor (2)

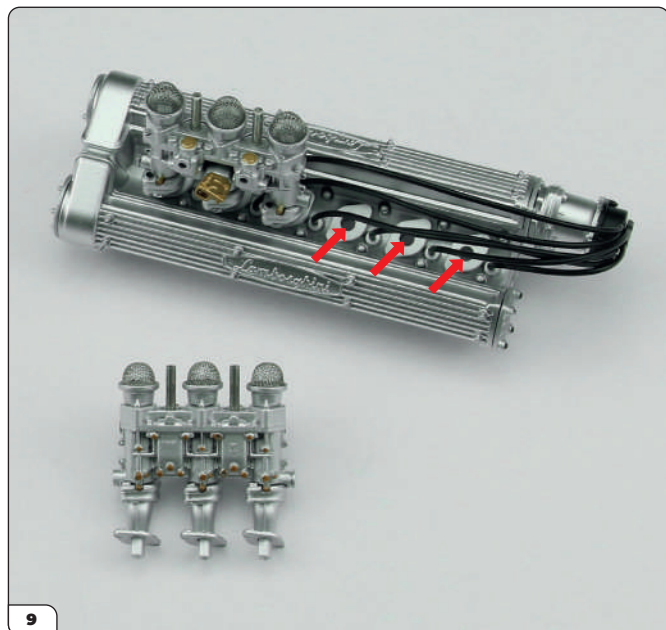

Take the right cylinder head from the previous stage. The carburettor will be fitted into the three holes between the spark plugs (arrows).



Fit the carburettor in place ensuring that the pins are pressed into the holes simultaneously and that it aligns with the other carburettor.

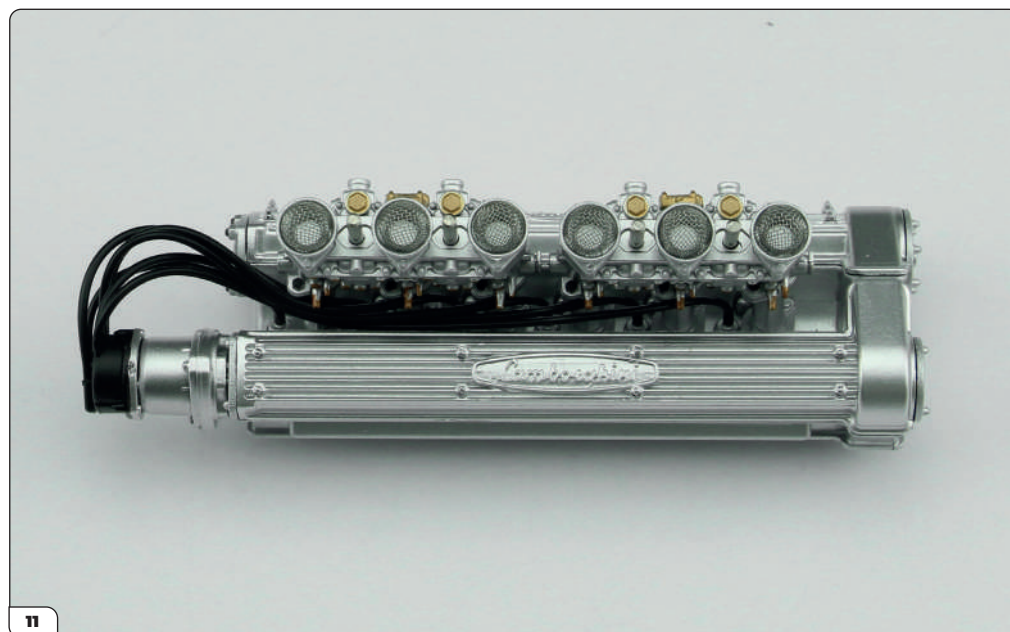

This image shows how the spark plug cables lead behind the carburettors on the cylinder head.



## Stage 15: Right Carburettor (2)

STAGE COMPLETE

