



Lamborghini MIURA



Pack 04

BUILD INSTRUCTIONS

STAGE 25: FITTING THE REAR WISHBONES

**STAGE 26: INSTALLING THE LEFT
REAR SHOCK ABSORBER**

**STAGE 27: INSTALLING THE RIGHT
REAR SHOCK ABSORBER**

**STAGE 28: MOUNTING THE ENGINE AND
FITTING DRIVE SHAFTS AND WHEEL HUBS**

**STAGE 29: ATTACHING THE
EXHAUST MANIFOLDS**

**STAGE 30: CONNECTING THE
EXHAUST MANIFOLDS**

STAGE 31: FITTING THE EXHAUST SILENCERS

**STAGE 32: ATTACHING THE UPPER FRAME
AND FUEL FILTER**

**STAGE 33: FITTING THE LEFT
REAR BRAKE DISC**

The "Automobili Lamborghini" and "Automobili Lamborghini Bull and Shield" trademarks, copyrights, designs and models are used under license from Automobile Lamborghini S.p.A, Italy.

Advice from the experts

Spare screws are included with each part. Occasionally, you may be instructed to keep spare or unused screws for a later stage. Keep these spares in a safe place and label them correctly.

Please make sure you don't mix up the screws. They look quite similar, but the threads do vary slightly. Using the wrong screws may damage the parts.

When securing parts together using multiple screws, fit each screw loosely to ensure all the parts are correctly aligned before gently tightening them firmly, but not overtight, in the order in which you placed them.

The screwdriver can be magnetized by stroking it with a magnet (fridge magnet, etc.) enabling it to hold the screws and make assembly easier.

If a screw is tight going into a metal part, do not force it as you may shear the head off. Remove it and put a tiny smear of Vaseline, soap or light oil on the thread. That will lubricate it and make it easier to drive home.

During the course of this build, you will receive many pieces that you will assemble immediately – following the instructions in the corresponding stage – and other pieces that you should store safely to one side, for use in future assembly stages.

Left and Right! When building your Lamborghini, the left or right hand side refers to each side as you are sitting in the car.



WARNING: Some parts are assembled using magnets. These magnets can cause serious injury if they are swallowed. Keep away from children. If you suspect a magnet has been swallowed, seek medical help straight away.

Stage 25: Fitting the Rear Wishbones

For the first stage of this Pack, you'll fit the wishbones onto the frame from stage 24. These will be used to hold the rear wheel hubs in place.



STAGE 25 PARTS LIST

Name
Rear arm brackets
Right rear upper wishbone
Left rear upper wishbone
Internal support (left and right)
Type A screws x3
Type B screws x3
Type G screws x3



Stage 25: Fitting the Rear Wishbones



The internal supports come packed in bags marked 'R' and 'L' to distinguish the right from the left one. You can also identify the left support from the right one by placing them as shown with the holes facing upwards. Set the right one aside for now.



Take the left rear upper wishbone and place on your work surface with the four rivets facing upwards. Align the left internal support with it. Insert the pin of the support into the large hole of the wishbone as shown.



Place the rear frame assembly upside down on your work surface alongside the left wishbone. Take one of the Type B screws. Note the hole in the frame for fitting the wishbone (arrow).



Fit the wishbone onto the frame by placing the internal support over the hole in the frame as shown.

Stage 25: Fitting the Rear Wishbones



Turn the frame over and locate the screw hole for fixing the wishbone in place and drive 1x Type B screw through.



Take the two rear arm brackets and place them with the flat edges (arrows) facing inwards as shown in the inset photo. Identify the left bracket from the right one. Set the right bracket aside and prepare to fit the left by taking a Type A screw.

Note the diamond-shaped protrusion on the frame (circled).

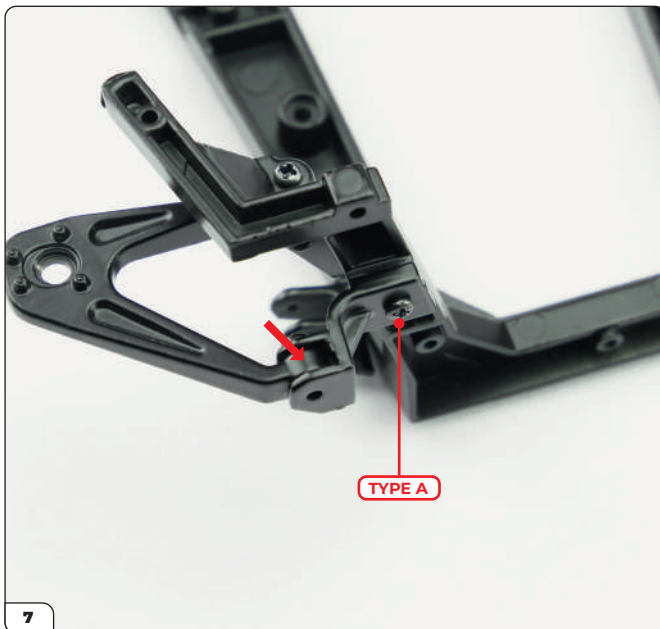

Fit the diamond-shaped recess of the bracket over the protrusion of the frame. At the same time, insert the other end of the bracket over the arm of the wishbone (arrow).

Use 1x Type A screw to fix the bracket to the frame.

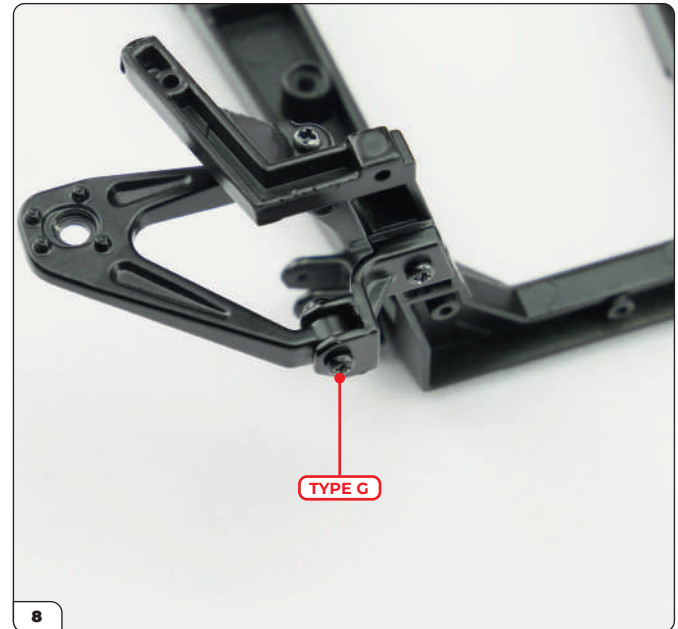

Secure the bracket to the wishbone using 1x Type G screw.

Stage 25: Fitting the Rear Wishbones



Now the right wishbone will be fitted by repeating steps 2 to 8. Take the right wishbone and internal support and fit the two parts together as you did for the left parts.



Position the internal support and wishbone onto the rear frame then secure it using 1x Type B screw.

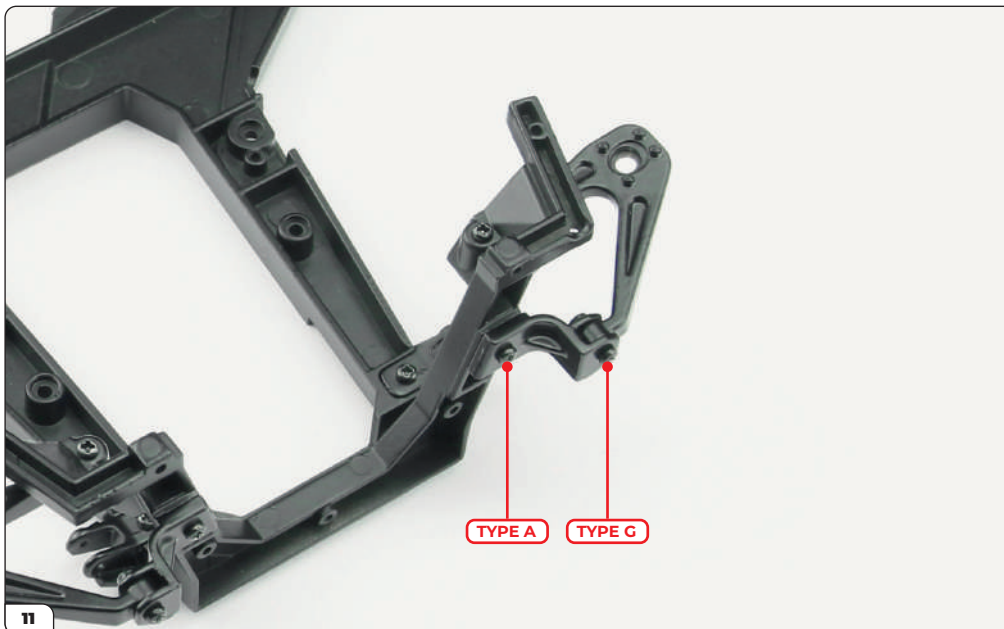

Then fit the right bracket in the same manner as step 7 and secure it in place using 1x Type A and 1x Type G screw.

Stage 25: Fitting the Rear Wishbones

STAGE COMPLETE

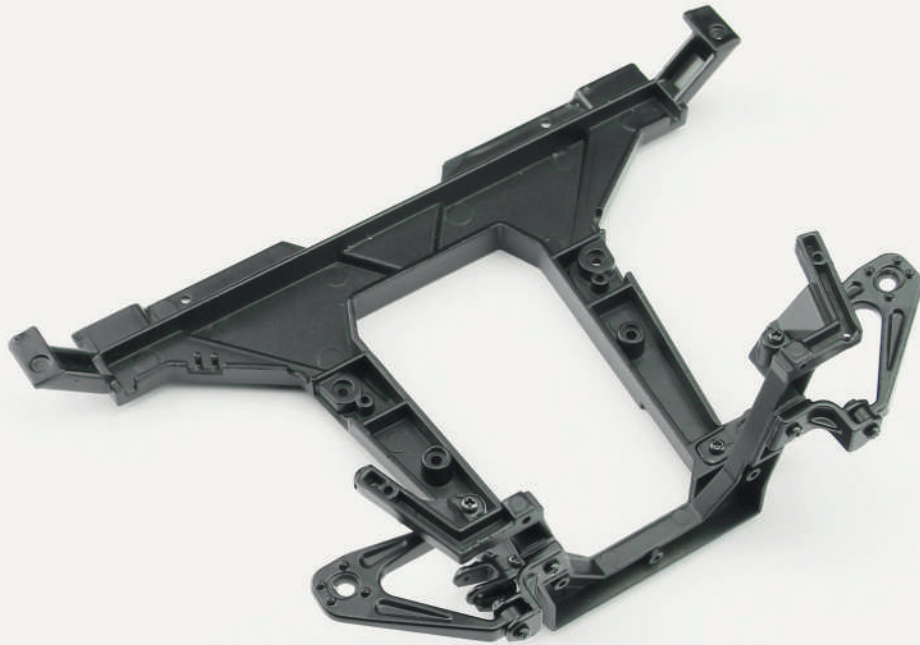

Stage 26: Installing the Left Rear Shock Absorber

Next you'll install the left rear shock absorber. You can test it by pressing the two ends together.



STAGE 26 PARTS LIST

Name
Left rear shock absorber
Left rear lower suspension arm
Tie rod
Type A screws x3
Type E screws x2
Type G screws x3

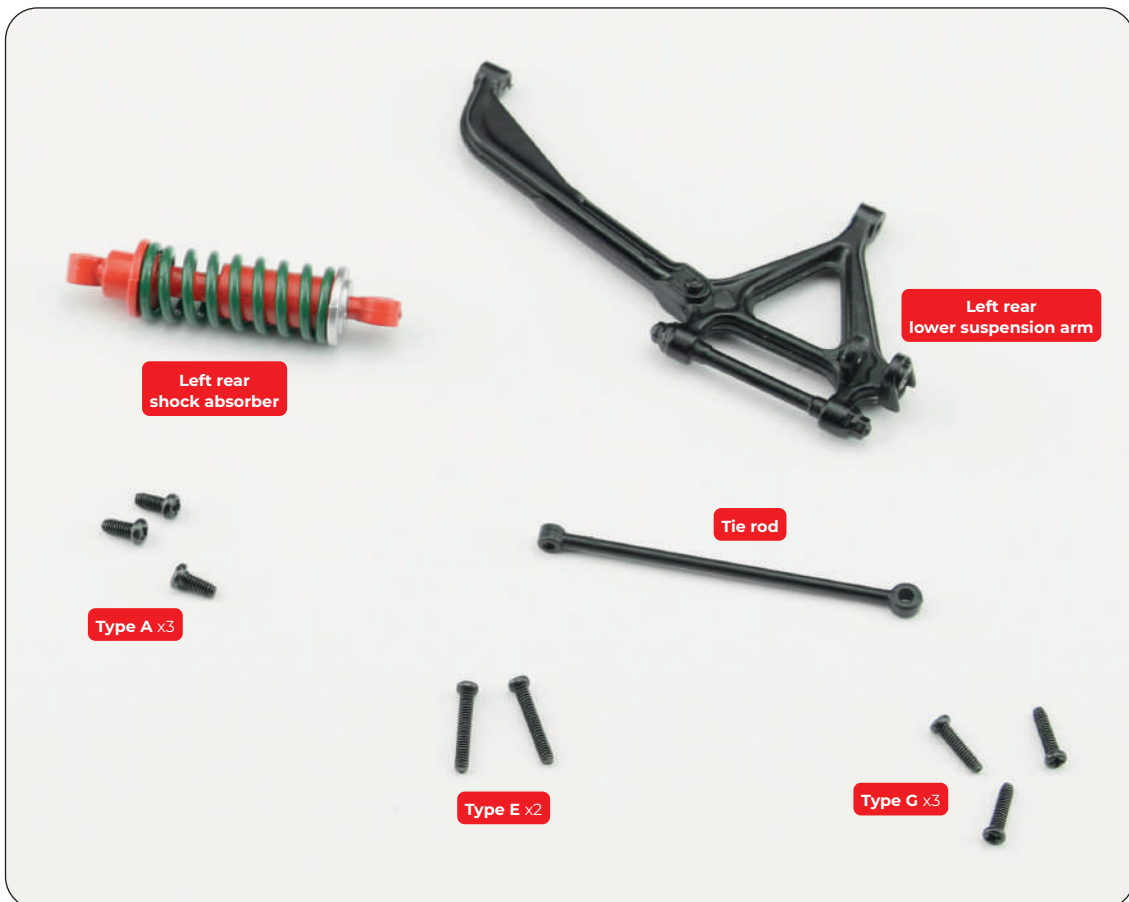

Stage 26: Installing the Left Rear Shock Absorber



Take the left rear lower suspension arm and align it with the corresponding front support from stage 24 as shown.

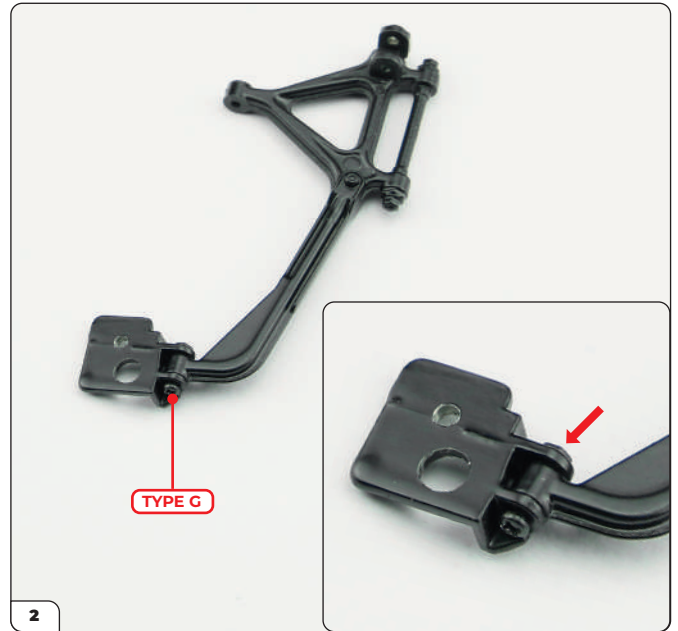

Fit the parts together then secure them using 1x Type G screw. Make sure to drive the screw into the parts through the side that is opposite a fake rivet (arrow).

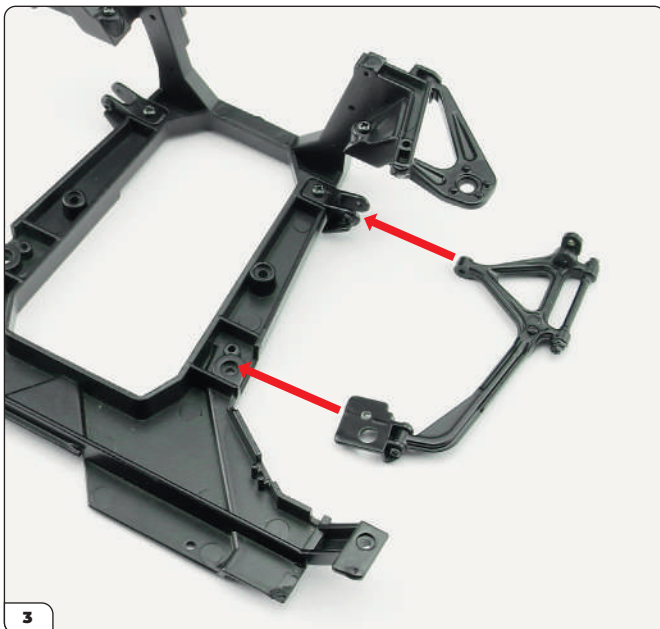

Place the rear frame assembly on your work surface and align the suspension arm with it as shown.



Fit the suspension arm onto the frame. Note the small hole in the front support (arrow). Take 1x Type A screw and drive it through the hole as shown in the inset image.

Stage 26: Installing the Left Rear Shock Absorber

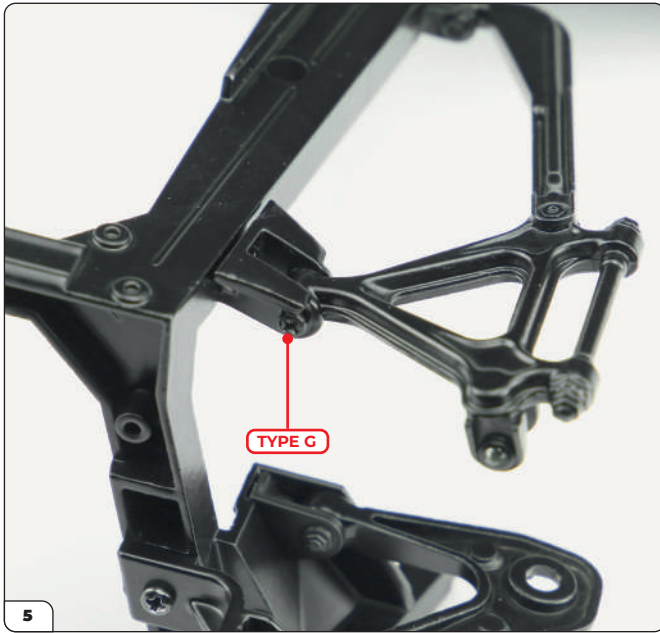

Move to the back of the frame and use 1x Type G screw to secure the other end of the suspension arm.

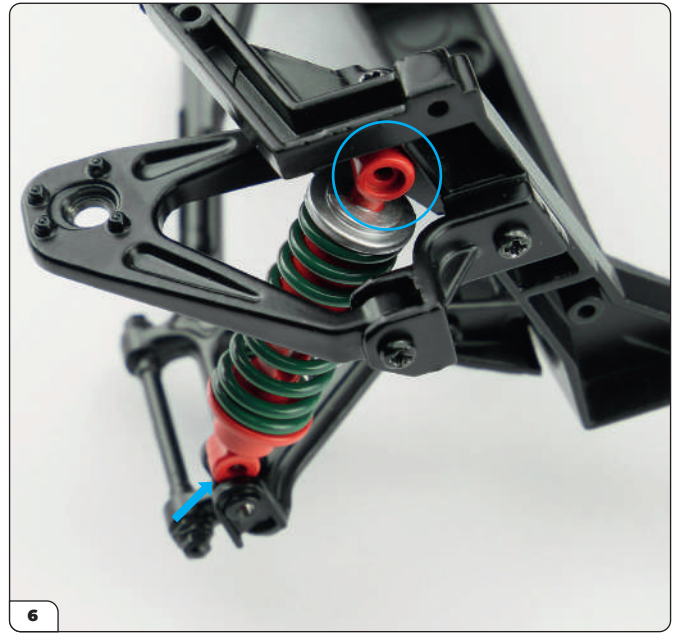

Take the shock absorber and place the hole located on the end with the silver plate over the corresponding spot as shown (circled). At the same time, fit the other end of the shock absorber into the suspension arm (arrow).



Secure the top of the shock absorber in place using 1x Type A screw.



The tie rod has a hole at either end – one of the holes is larger than the other. Align the larger hole with the assembly as shown.

Take 1x Type E screw which will fit through the large hole of the tie rod and into the suspension arm and shock absorber (arrows).

Stage 26: Installing the Left Rear Shock Absorber

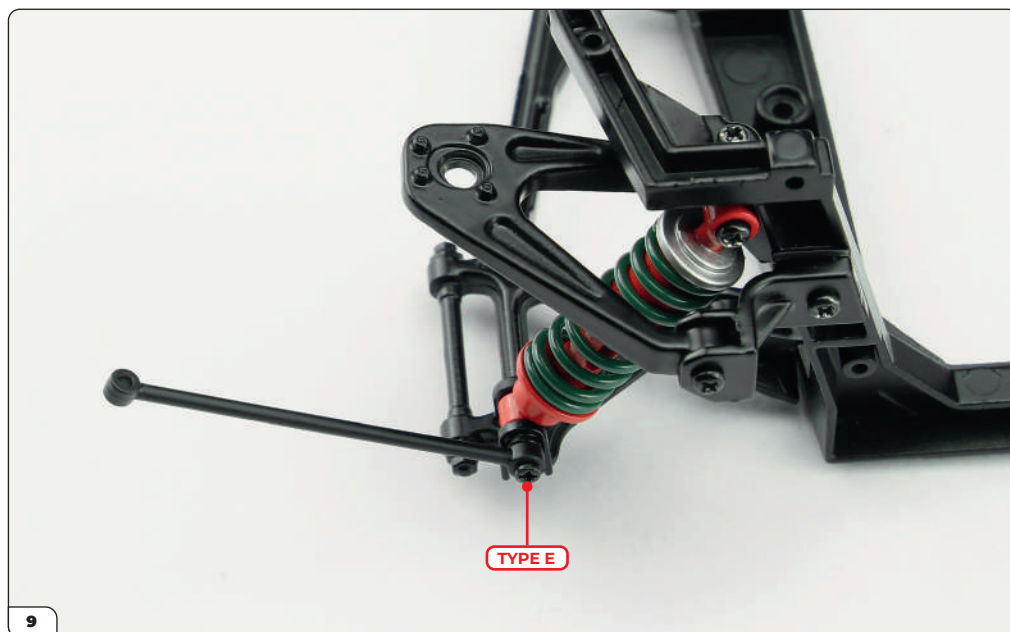

Fix the parts together using the 1x Type E screw. Note that the tie rod should be able to rotate so don't overtighten the screw.



Stage 27: Installing the Right Rear Shock Absorber

For this stage you'll follow the same steps as before to install the right rear shock absorber onto the frame.



STAGE 27 PARTS LIST

Name
Right rear shock absorber
Right rear lower suspension arm
Tie rod
Type A screws x3
Type E screws x2
Type G screws x3

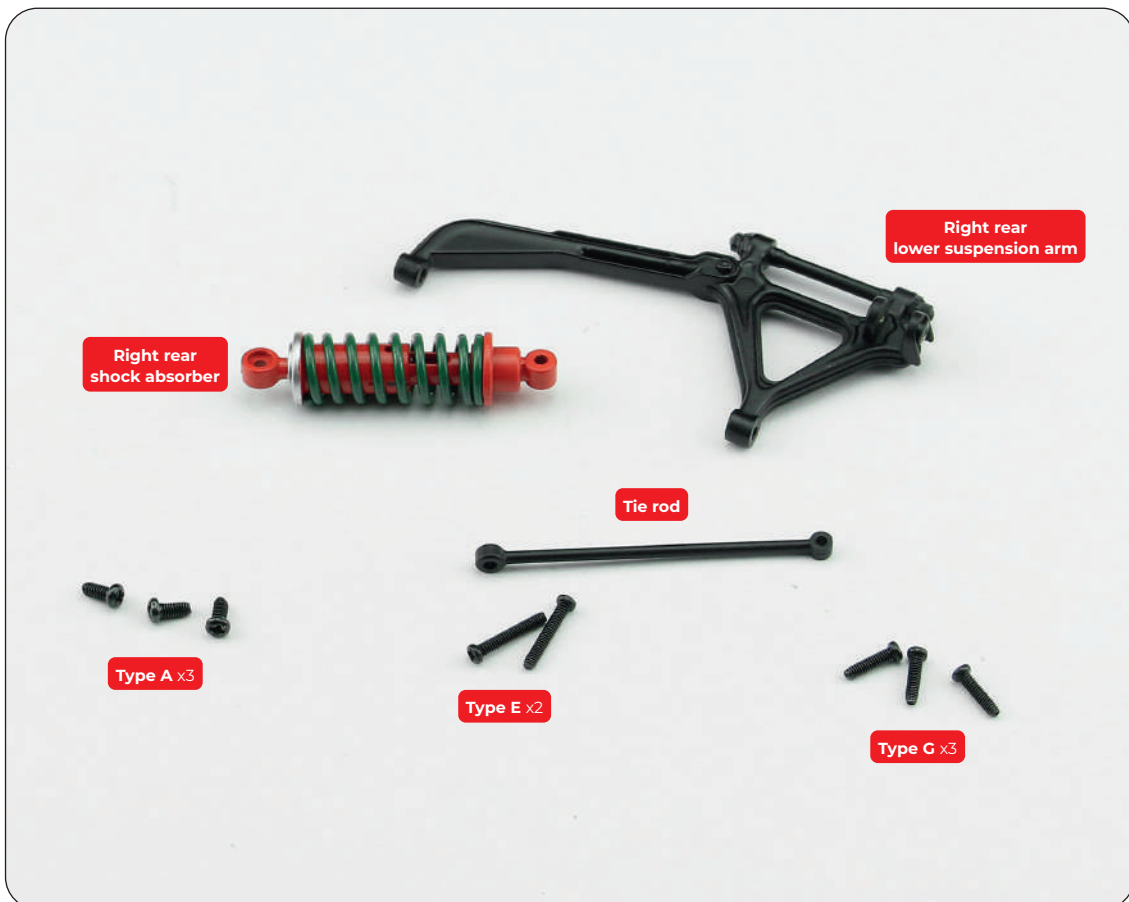

Stage 27: Installing the Right Rear Shock Absorber



Take the right rear lower suspension arm and align it with the corresponding front support from stage 24 as shown.



Fit the parts together then secure them using 1x Type G screw. Make sure to drive the screw into the parts through the side that is opposite a fake rivet (arrow).



Align the suspension arm with the frame as shown, then prepare 1x Type A and 1x Type G screw.



Fit the suspension arm in place as you did in the previous stage and secure the front support to the frame using 1x Type A screw.

Stage 27: Installing the Right Rear Shock Absorber



Move to the back of the frame and use 1x Type G screw to secure the other end of the suspension arm.



Next fit the shock absorber in place as you did in step 6 from stage 26. Secure the top of the shock absorber using 1x Type A screw.



Take a Type E screw and push it through the larger hole in the tie rod, then fit into the suspension arm and shock absorber as shown.

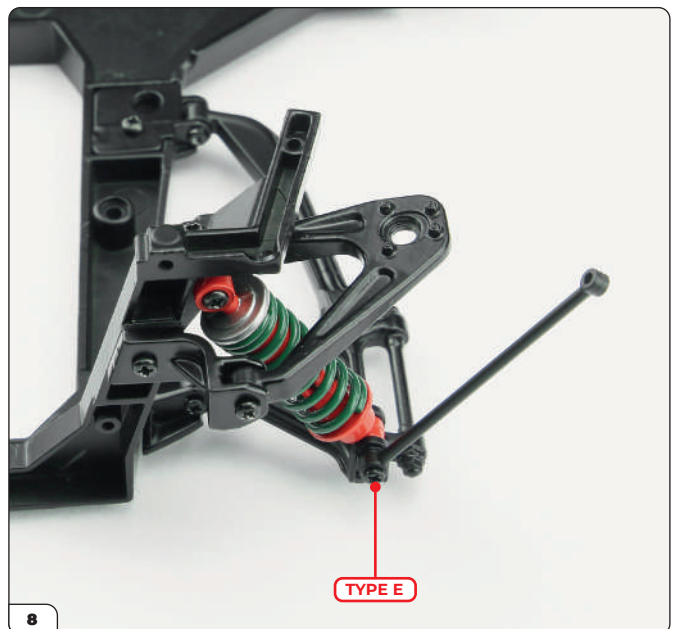

Secure the parts together by tightening the 1x Type E. Make sure the tie rod is still able to rotate.

Stage 27: Installing the Right Rear Shock Absorber



Stage 28: Mounting the Engine and Fitting Drive Shafts and Wheel Hubs

With the rear shock absorbers installed you'll now mount the engine of your Lamborghini Miura onto the rear frame, then fit the rear drive shafts and wheel hubs.



STAGE 28 PARTS LIST

Name
Right rear drive shaft
Left rear drive shaft
Left rear wheel hub
Right rear wheel hub
Left rear wheel hub plate
Right rear wheel hub plate
Type A screws x5
Type B screws x3
Type F screws x3

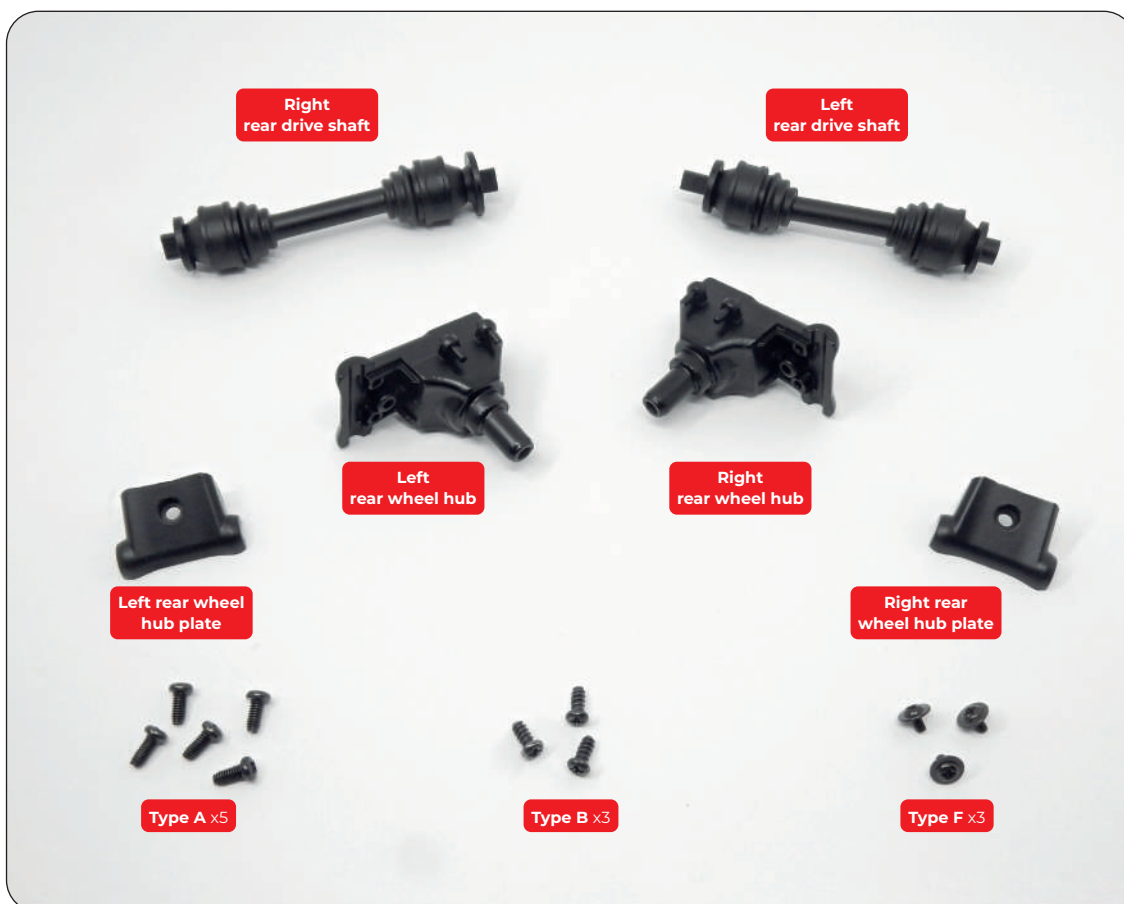

Stage 28: Mounting the Engine and Fitting Drive Shafts and Wheel Hubs

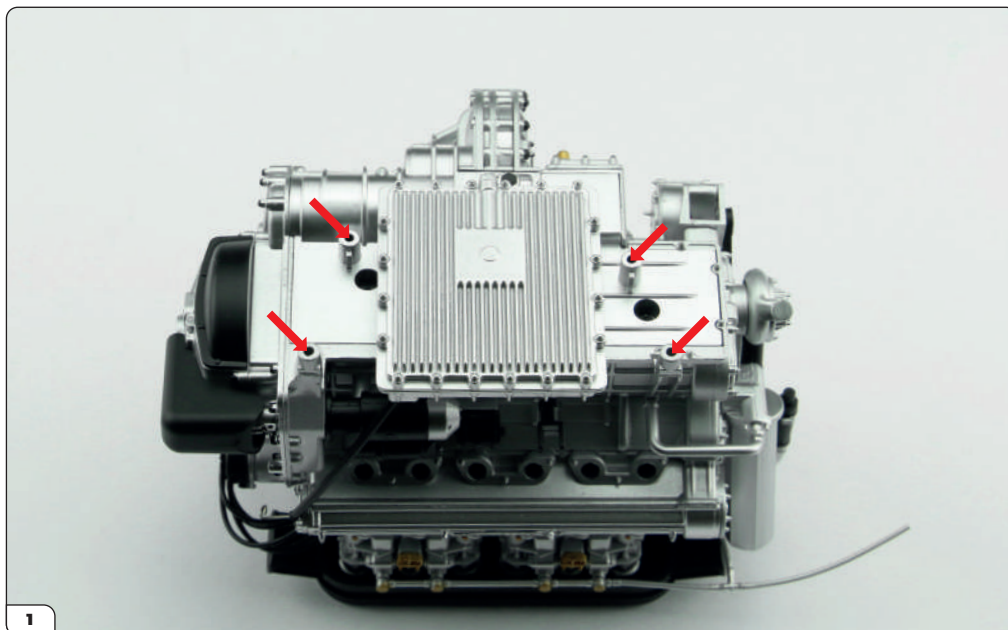

Place the engine assembly from stage 23 upside down on your work surface as shown. We recommend using a protective surface to avoid damaging the paint on the air filter boxes.

Note the four screw holes (arrows) on the assembly.

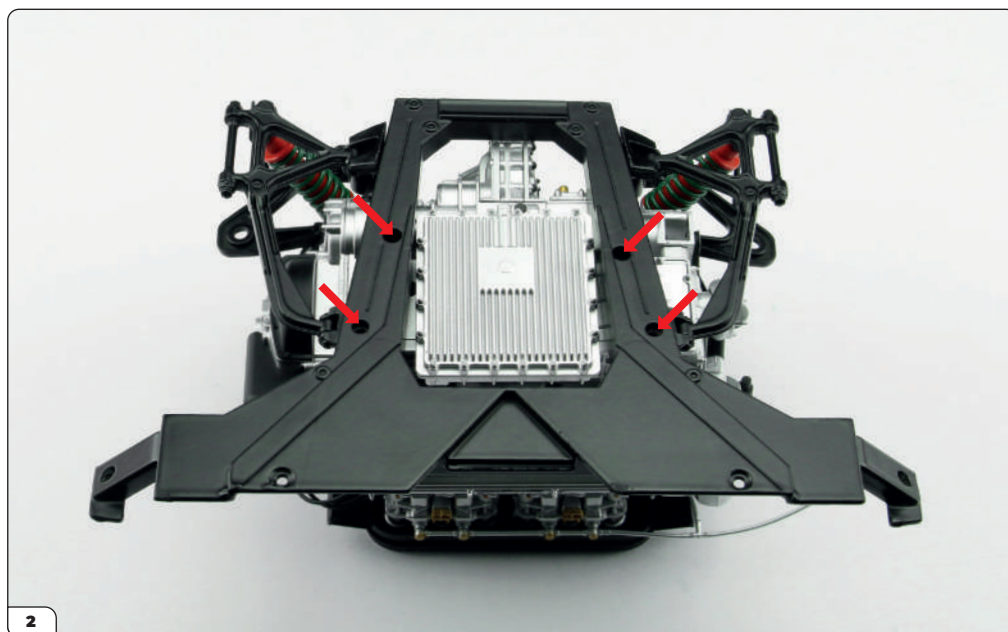

Take the rear frame from the previous stage and fit it onto the engine assembly. Use the points highlighted in the previous step as a guide by placing the corresponding holes over them.

Stage 28: Mounting the Engine and Fitting Drive Shafts and Wheel Hubs

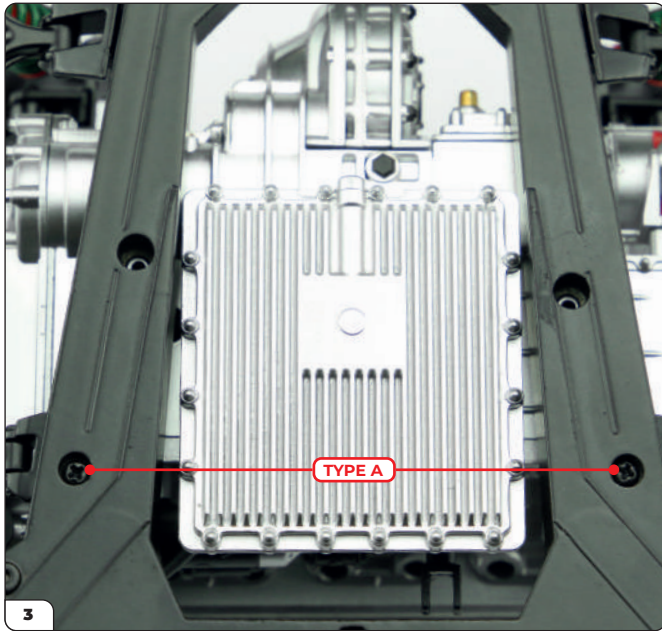

Drive 2x Type A screws into the holes located towards the wider end of the rear frame.

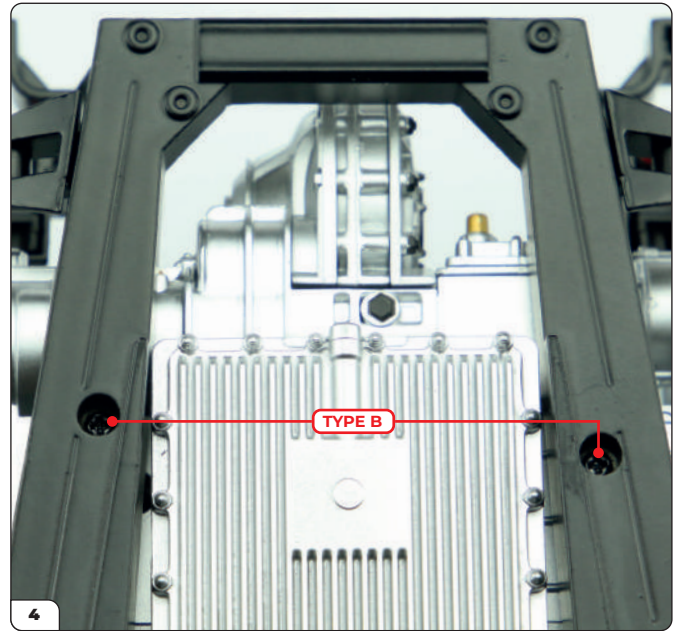

Then fasten 2x Type B screws into the holes towards the narrower end of the rear frame.

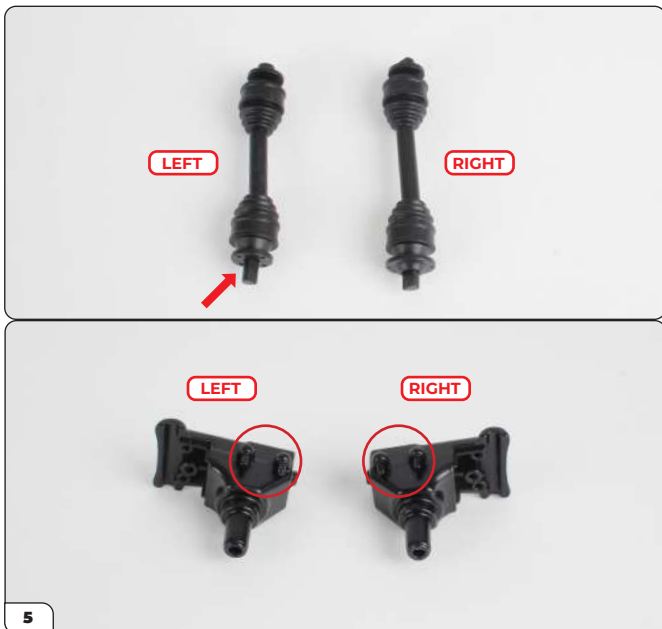

Take the drive shafts and the rear wheel hubs and lay them on your work surface as shown.

Note that the left drive shaft has a longer pin (arrow) and that the wheel hubs have two pins on one side (circled).

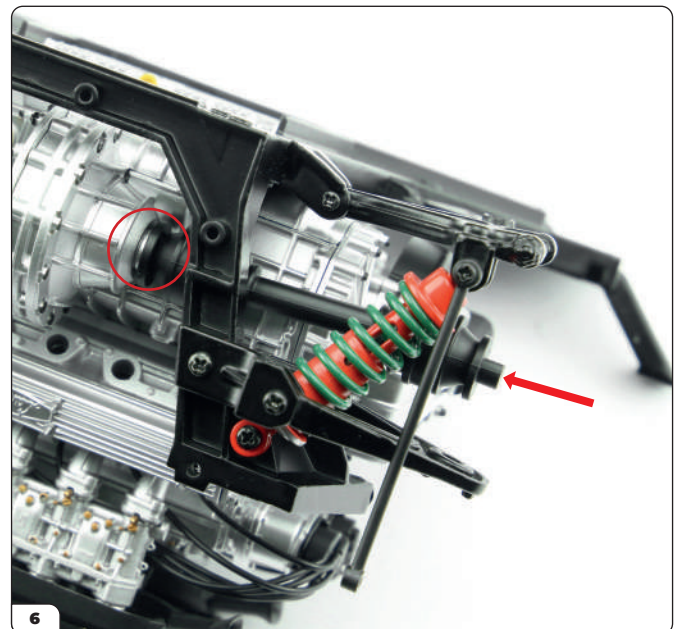

Keeping the frame and engine assembly in place, locate the gearbox and insert the D-shaped longer pin of the left rear drive shaft into the D-shaped hole on the left side of the gearbox (circled).

Stage 28: Mounting the Engine and Fitting Drive Shafts and Wheel Hubs

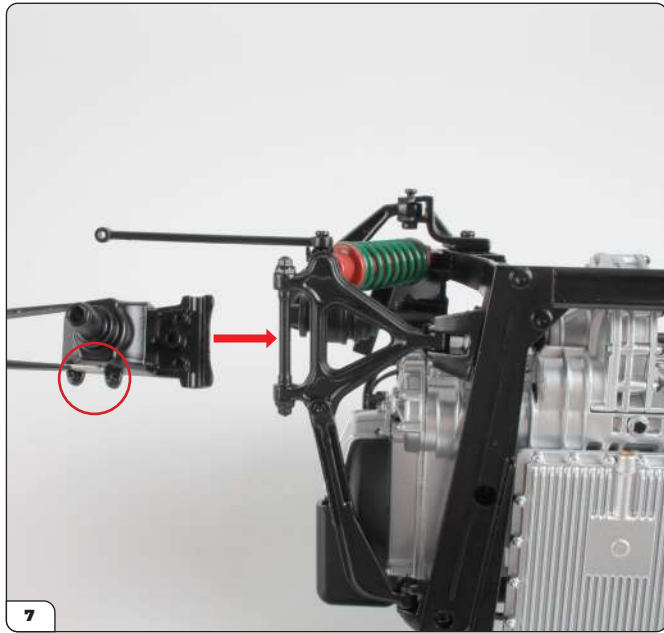

7 Take the left rear wheel hub (note the two pins, circled) and align it with the left suspension arm as shown.

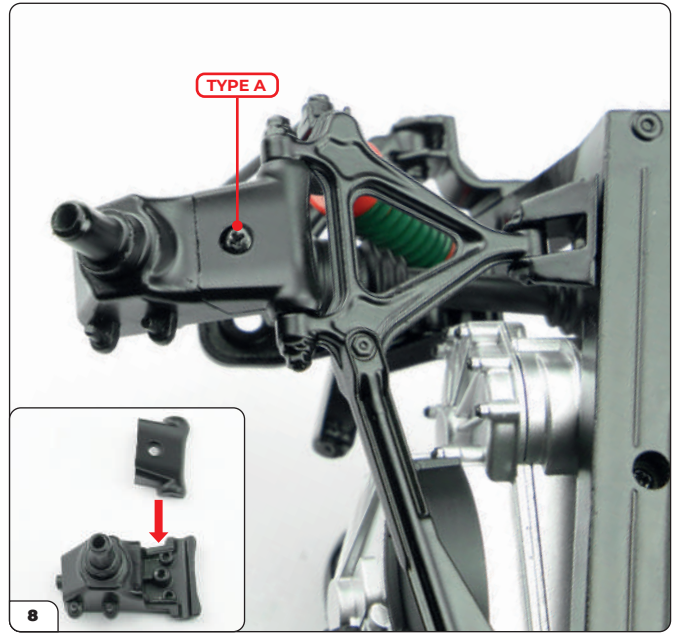

8 Fit the wheel hub onto the bar of the suspension arm then push the wheel hub plate over it. Secure the wheel hub using 1x Type A screw.

The inset image shows the plate and the corresponding holes on the wheel hub for fitting the parts together



9 Turn the assembly over carefully and place it on the work surface. Push the wheel hub so that the large hole fits over the pin of the drive shaft (arrow). At the same time, fit the hole at the top of the wheel hub into the corresponding hole in the wishbone (circled).

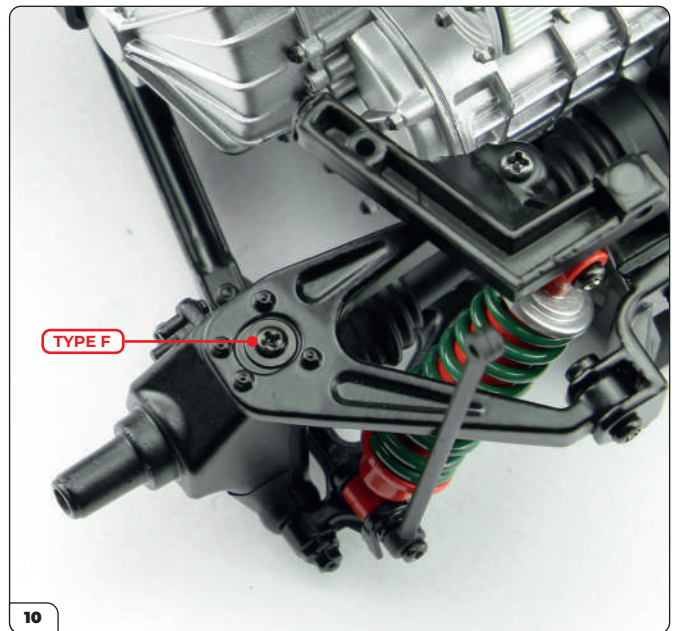

10 Fix the wheel hub and wishbone together using 1x Type F screw.

Stage 28: Mounting the Engine and Fitting Drive Shafts and Wheel Hubs

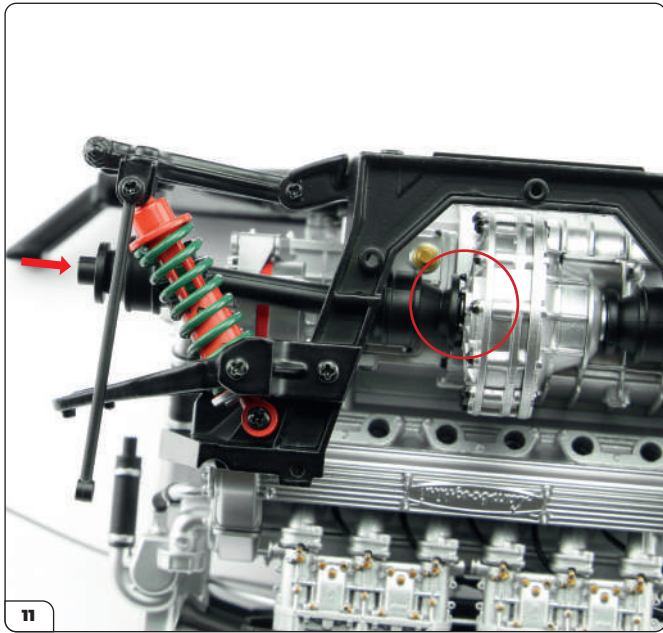

Fit the right drive shaft into the other side of the gearbox (circled) so that it mirrors the left drive shaft.

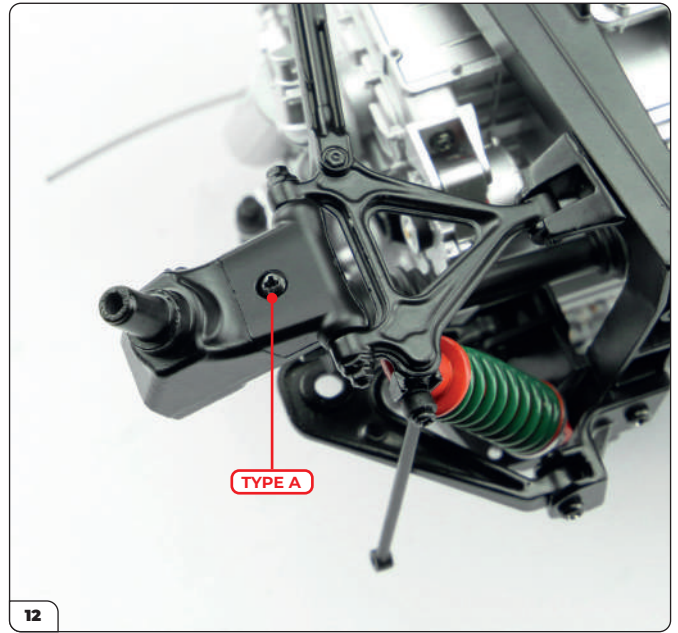

As you did in step 7 and 8, fit the wheel hub onto the bar of the suspension arm then push the wheel hub plate into place. Fix the parts together using 1x Type A screw.

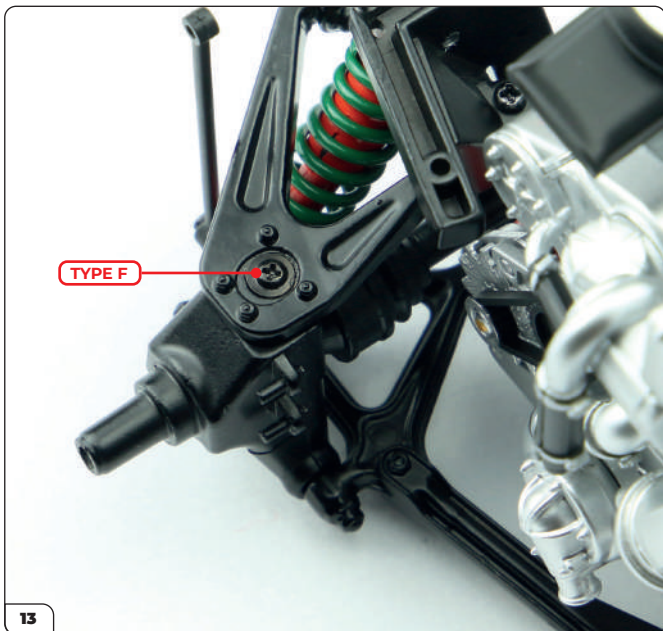

Finally, turn the assembly over and push the wheel hub into place in the same manner as step 9, so that it connects with the drive shaft and wishbone. Secure it using 1x Type F screw.

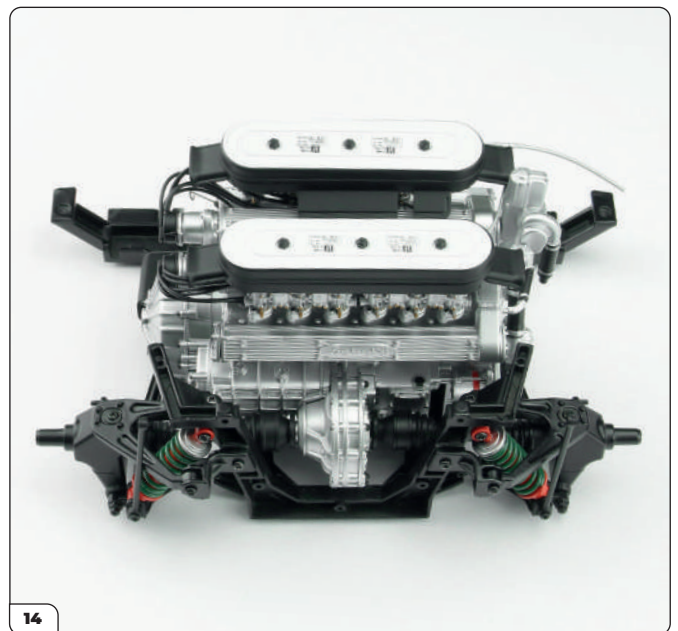

The engine has now been mounted to the rear frame and the wheel hubs are connected to the suspension.

Stage 28: Mounting the Engine and Fitting Drive Shafts and Wheel Hubs

STAGE COMPLETE



Stage 29: Attaching the Exhaust Manifolds

In this stage you'll fit the exhaust manifolds onto the engine and make preparations to the rear frame for the next stage.



STAGE 29 PARTS LIST

Name
Silencer support plate
Rear exhaust manifolds
Type A screws x4



Stage 29: Attaching the Exhaust Manifolds

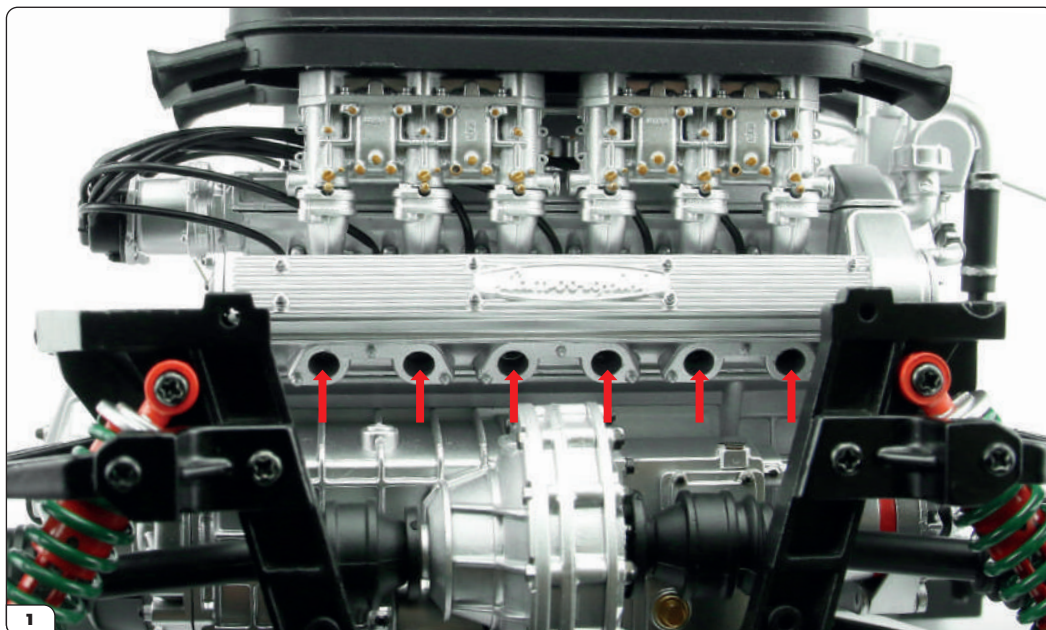

Take the rear frame assembly and place it on your work surface. Note the six holes for inserting the exhaust manifold (arrows).

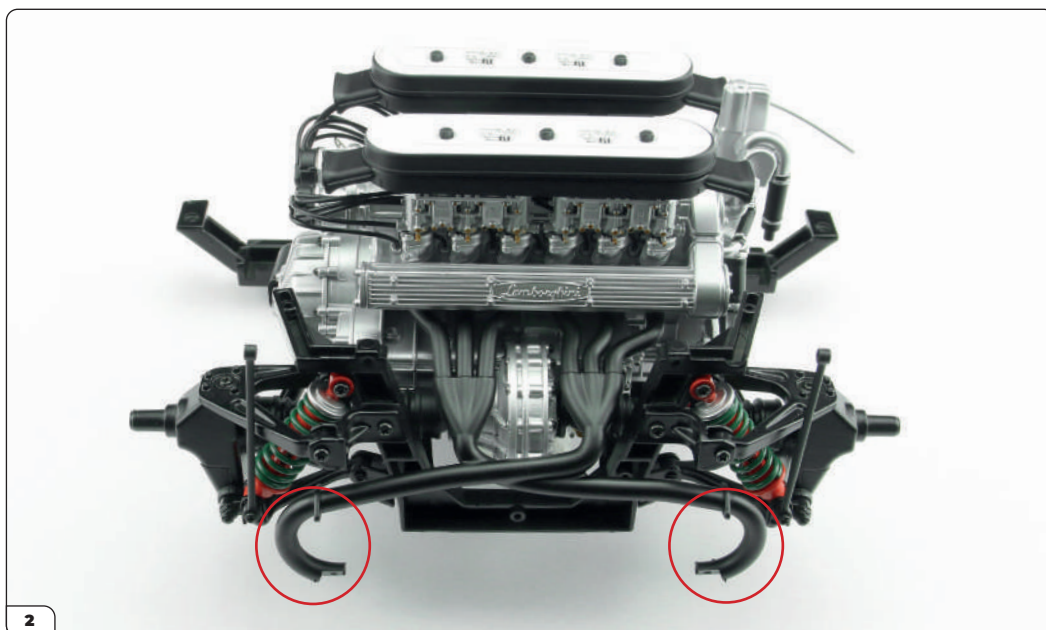

Push the pins on the exhaust manifold into the six holes. The two curved ends of the manifold should be facing downwards as shown (circled).

Stage 29: Attaching the Exhaust Manifolds

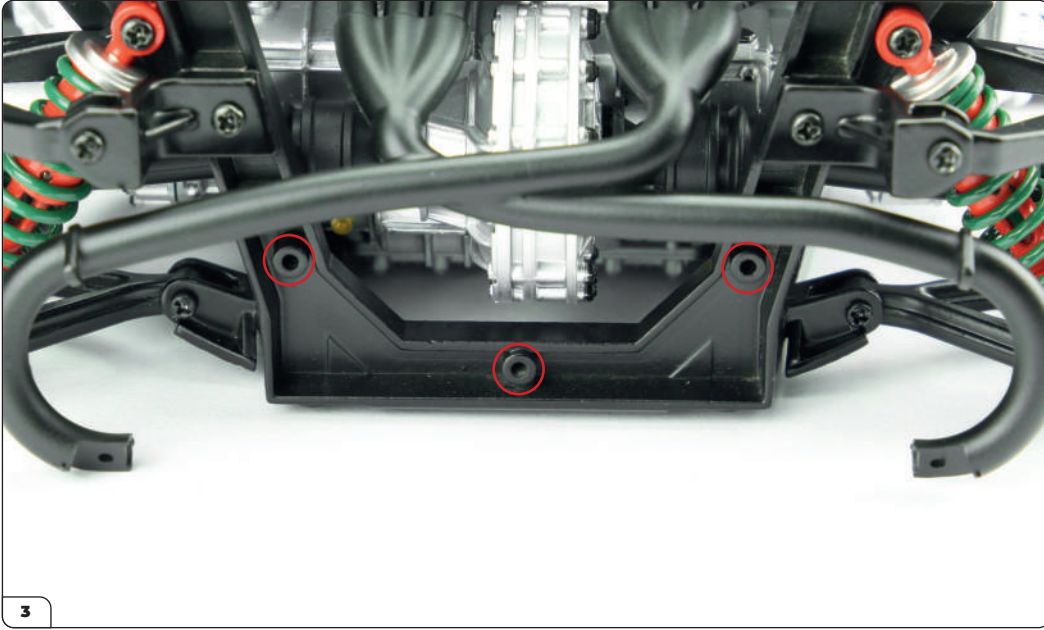

There are three holes in the rear frame below the exhaust manifold (circled) where the silencers will be installed in a future stage. We recommend preparing these three holes at this stage.

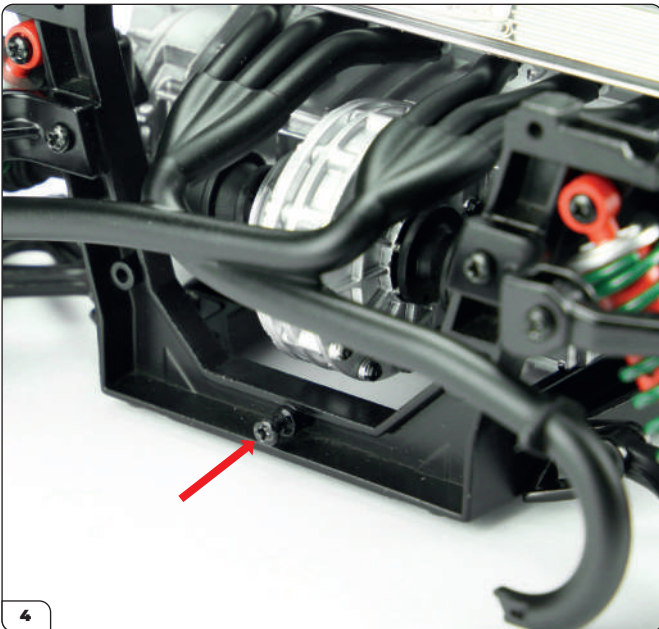

Start by driving a Type A screw into one of the holes then unscrew and retighten carefully (arrow). Take care not to break the screw and use a drop of oil if necessary.

Remove the screw and repeat for the other two holes.

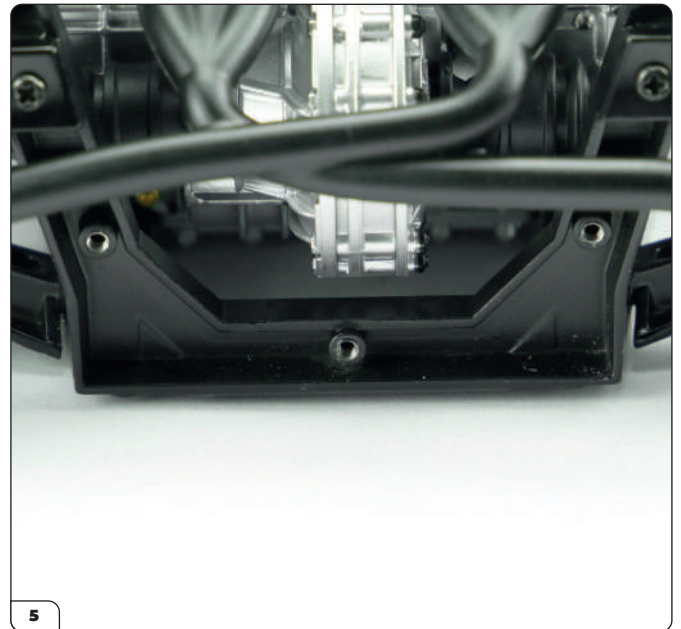

The image shows the holes after the screw has been drilled into each one, which will make installing the silencers easier in the next stage.

Keep the Type A screws from this stage safely aside along with the silencer support plate.

Stage 29: Attaching the Exhaust Manifolds

STAGE COMPLETE

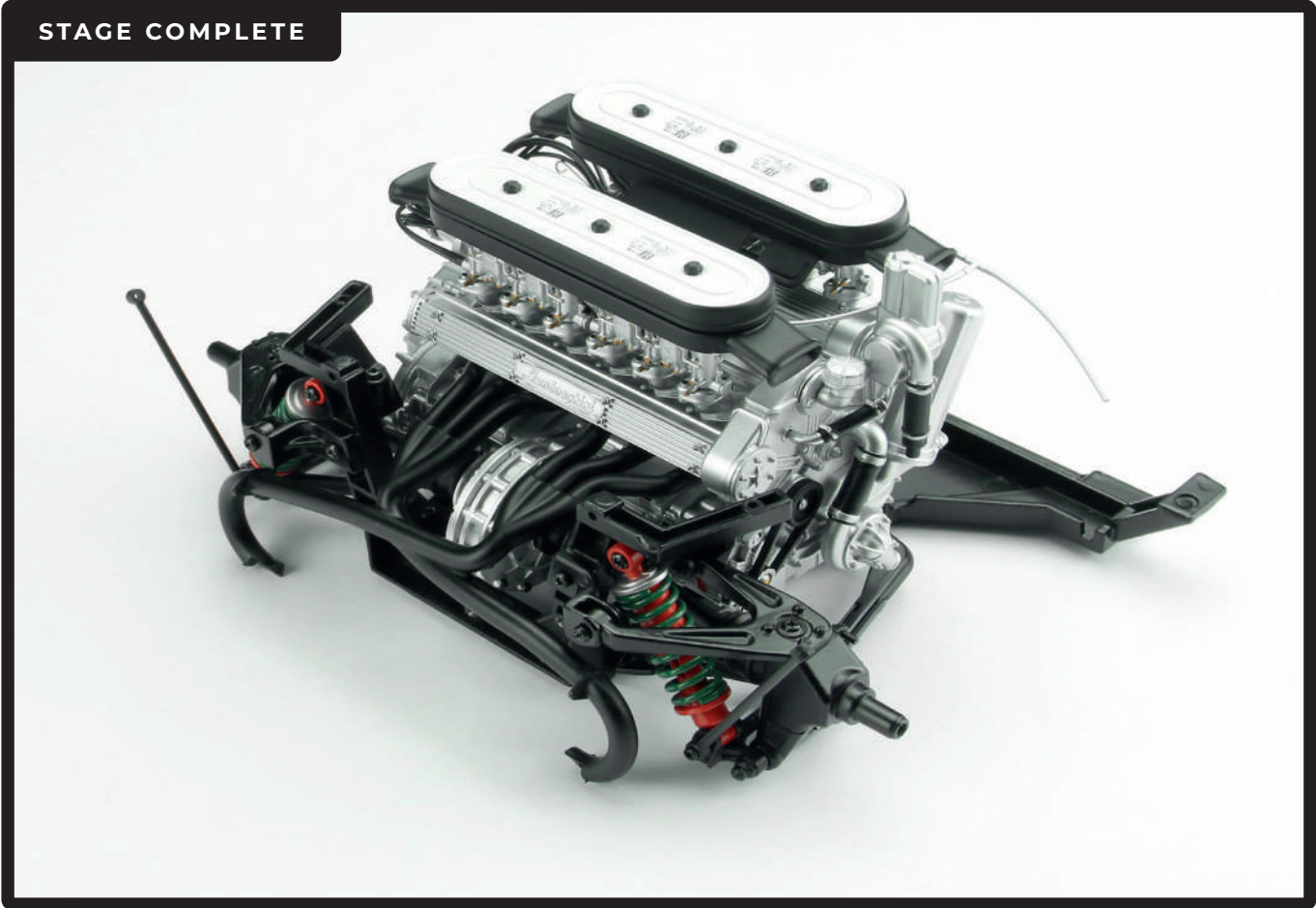

Stage 30: Connecting the Exhaust Manifolds

Next the exhaust support plate will be fitted to the rear frame, then the exhaust pipes will be connected.



STAGE 30 PARTS LIST

Name
Left front exhaust manifold
Exhaust pipe
Right front exhaust manifold
Type H screws x3

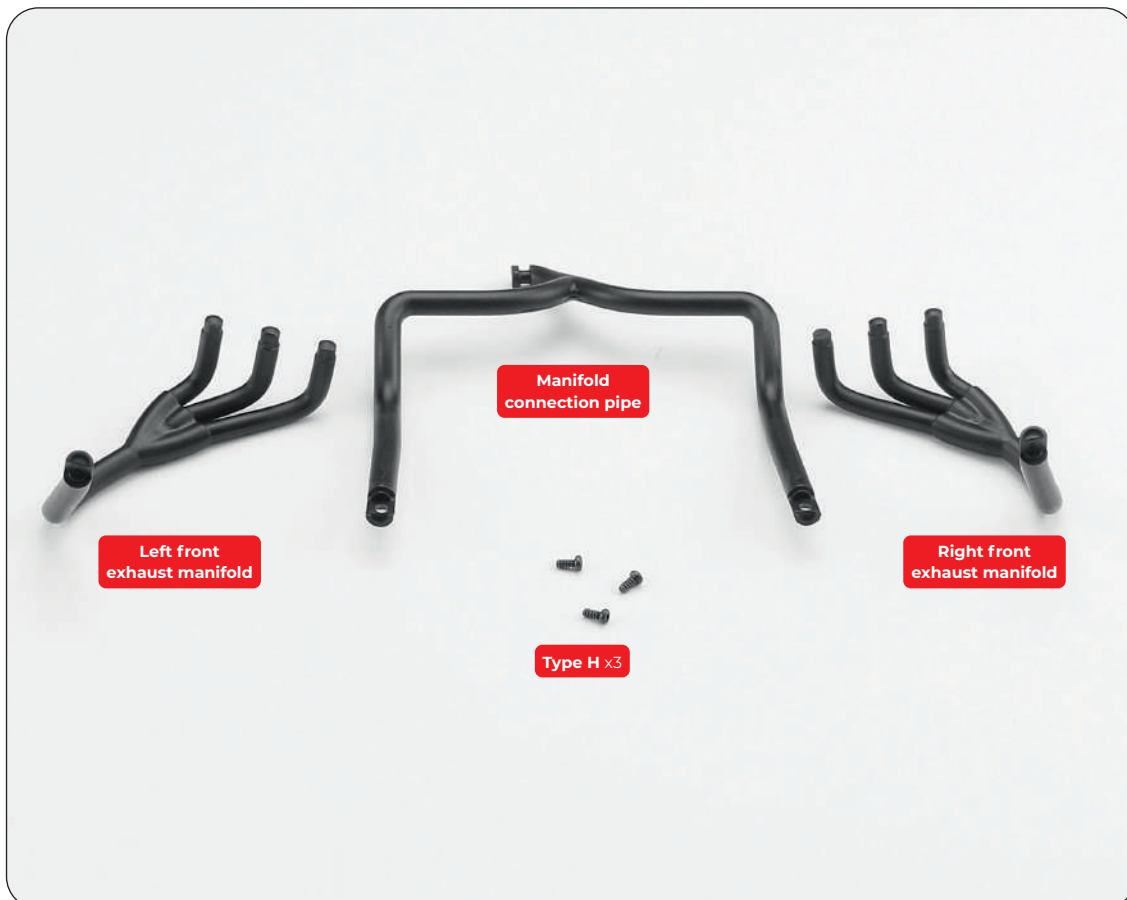

Stage 30: Connecting the Exhaust Manifolds

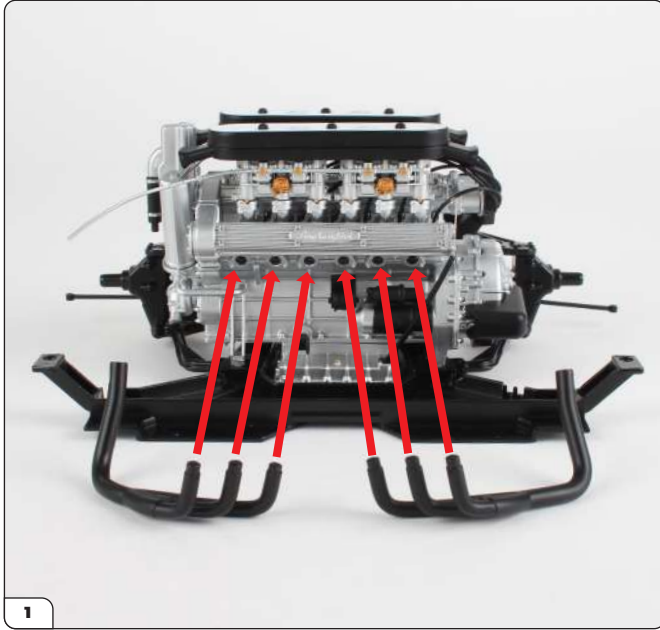

Place the rear frame assembly on your work surface in the orientation shown and align the left and right front manifolds. There are six holes in the engine for fitting the manifolds (arrows).

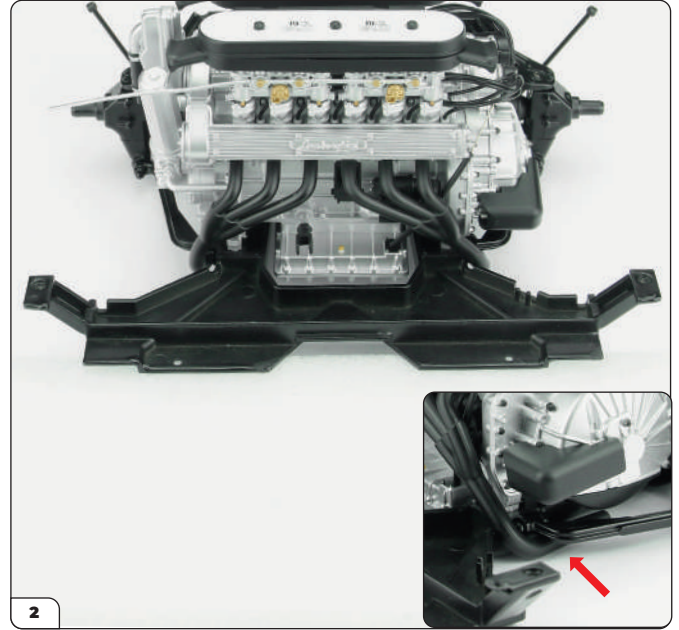

Push the manifolds into the holes. The ends of each one will lead towards the bottom of the rear frame assembly (inset, arrow).

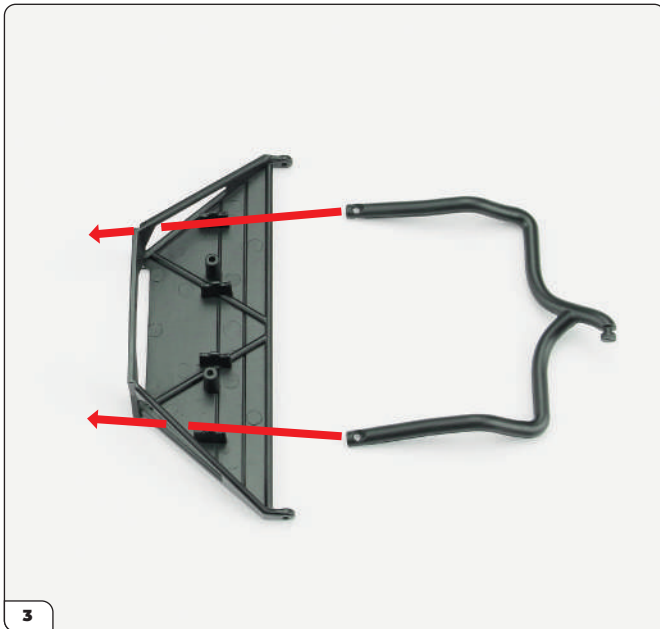

Take the silencer support plate from stage 29 and align the exhaust pipe with it as shown.



Fit the two ends of the connection pipe through the gaps in the silencer support as shown. The inset image shows the gap highlighted in blue. We recommend pushing one end entirely through first, then manoeuvre the other side in place.

Stage 30: Connecting the Exhaust Manifolds

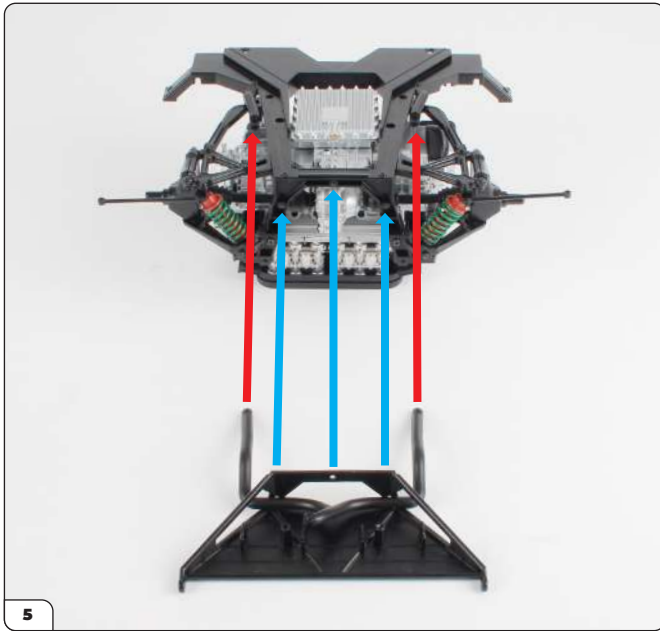

Carefully turn the rear frame assembly upside down then align the silencer support plate in place as shown. The red arrows show the connection of the pipes, while the blue arrows indicate the screw holes for fixing the support plate. It is essential to ensure that the silencer support plate brackets are fully located in the recesses in the rear frame assembly. Remove any burrs, mould marks and excess paint until they fit in place easily.

[Click here to see the official build diary, stage 95, for more details.](#)

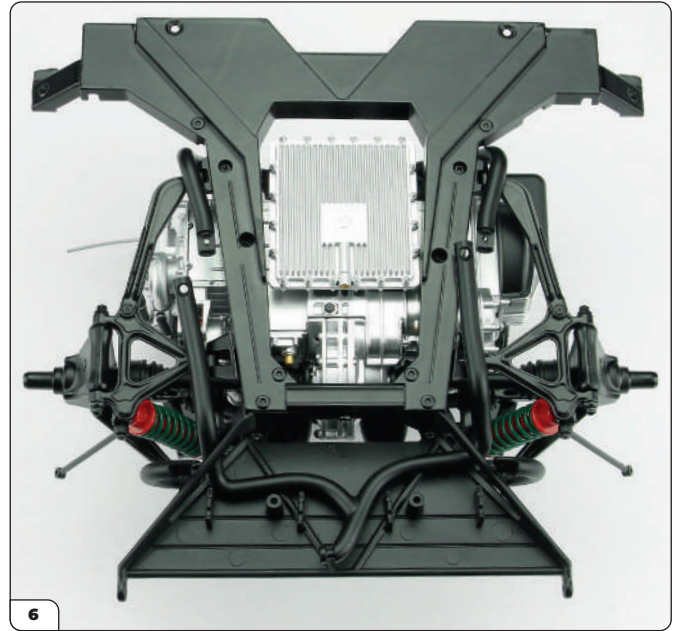

Fit the support plate in place. Make sure the connection pipes are above the suspension arms (circled).

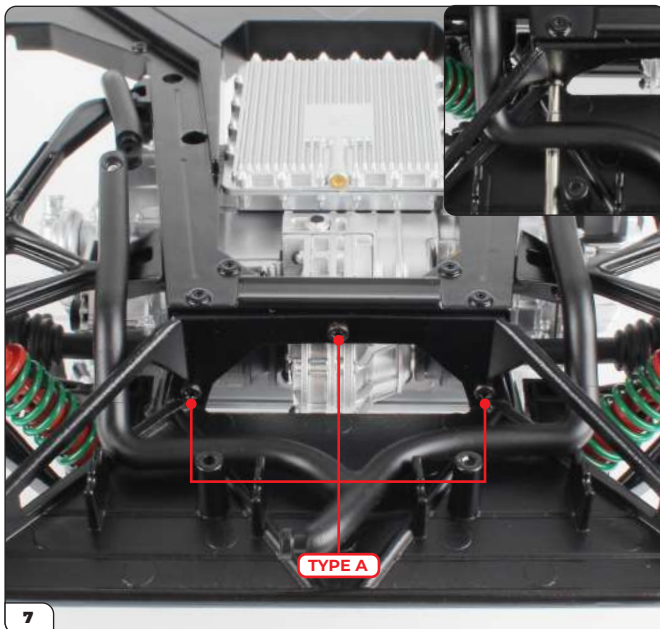

Secure the plate to the frame using 3x Type A screws from the stage 29. These are the holes that were pre-drilled in step 4 of that stage. We recommend lifting the pipe up and inserting the screwdriver underneath (inset) to avoid scratching the parts.

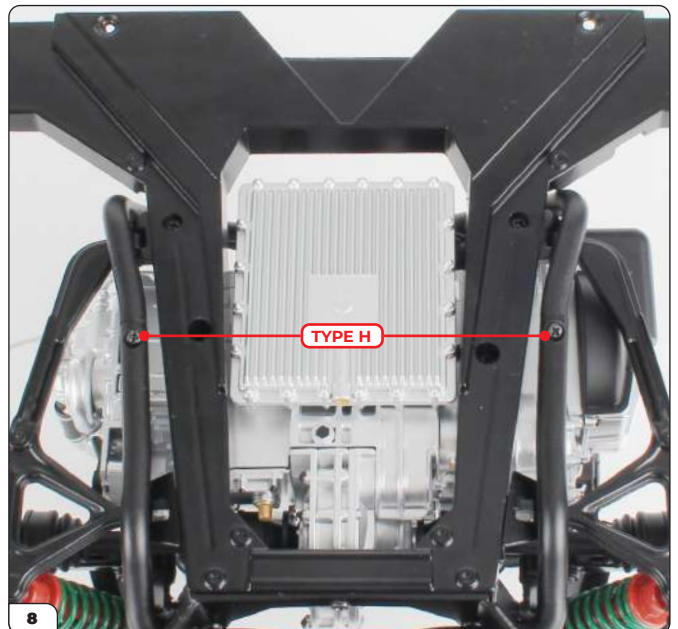

Attach the connecting pipes together using 2x Type H screws.

Stage 30: Connecting the Exhaust Manifolds

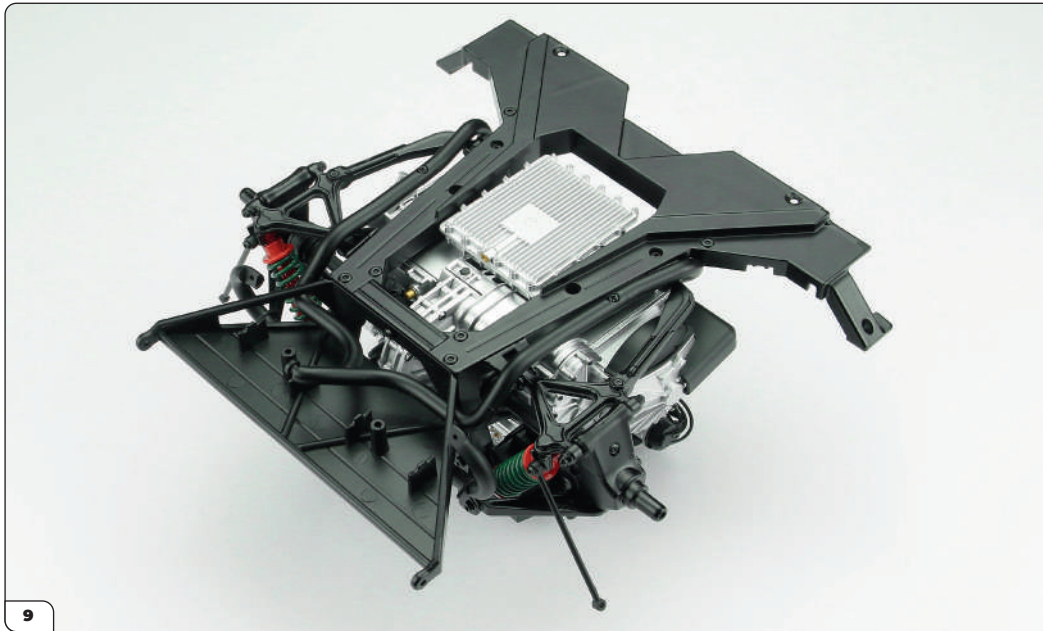

The assembly should now look like this.



Stage 31: Fitting the Exhaust Silencers

To complete installing the exhausts on your Lamborghini Miura, the silencers are installed onto the support plate.



STAGE 31 PARTS LIST

Name
Right silencer (lower part)
Exhaust pipe
Left silencer (lower part)
Right silencer (upper part)
Left silencer (upper part)
Type A screws x3
Type H screws x3

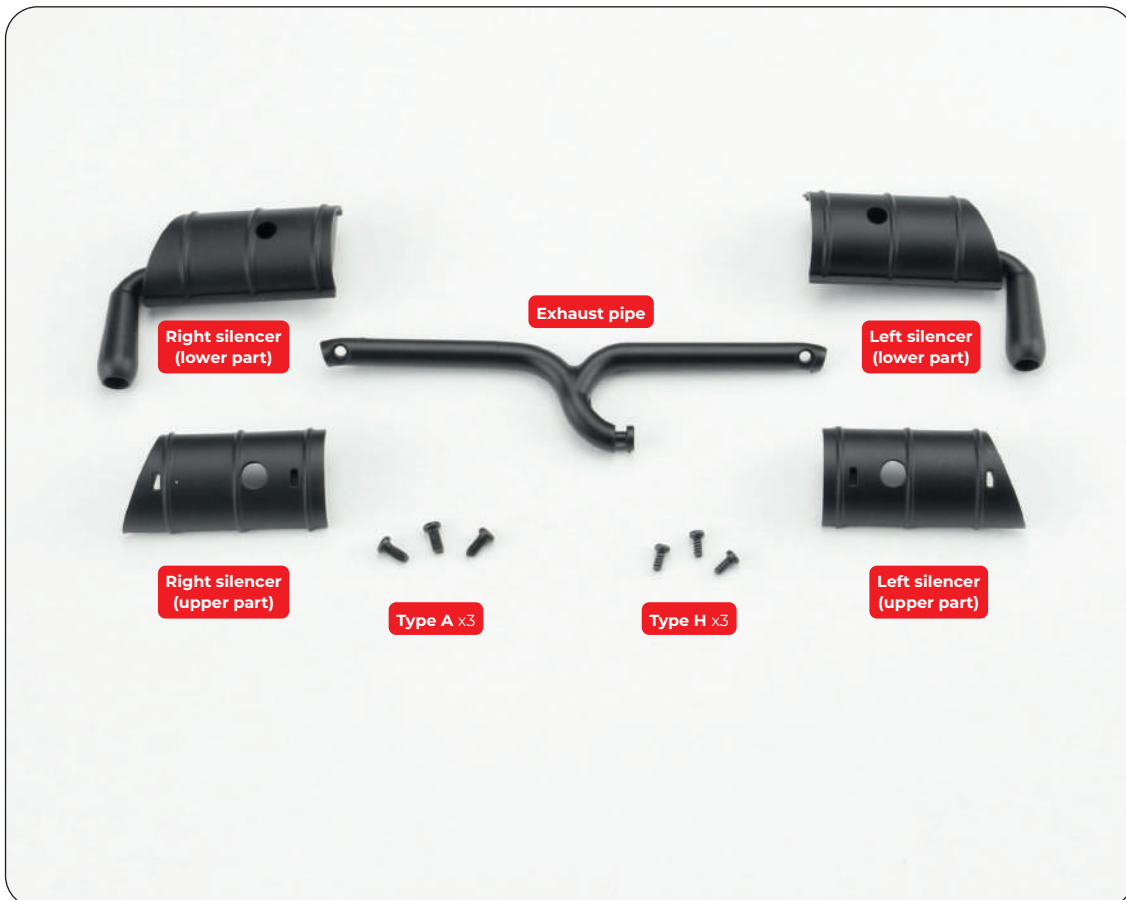

Stage 31: Fitting the Exhaust Silencers

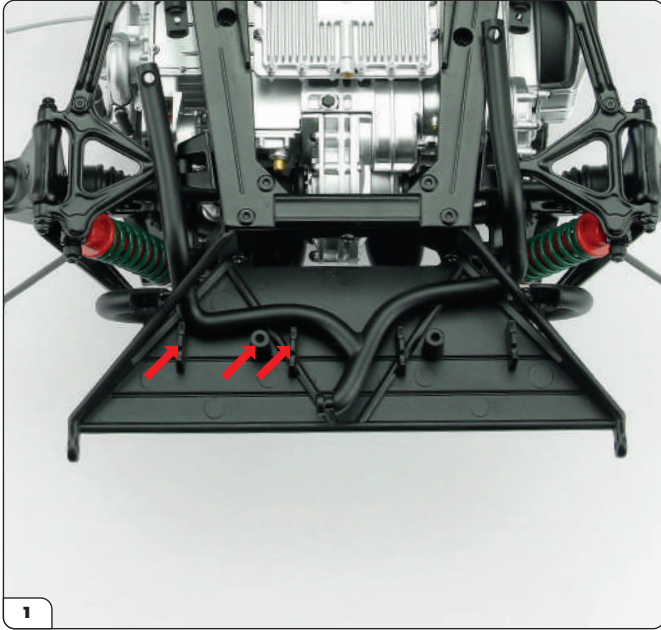

Place the rear frame assembly upside down on your work surface as shown. Note the support points for the right silencer (upper part) indicated by the arrows.

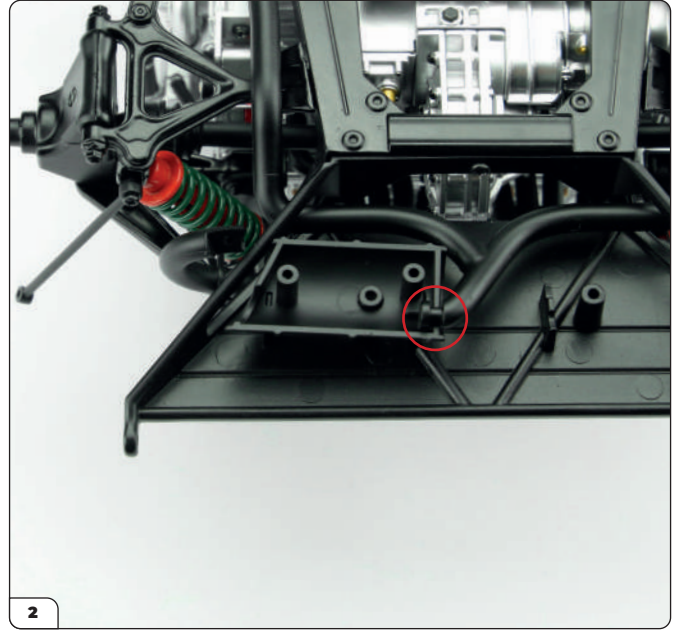

Lift the end of the exhaust pipe fitted in stage 30 and fit it into the right silencer (circled) before placing the silencer onto the support points highlighted in step 1.

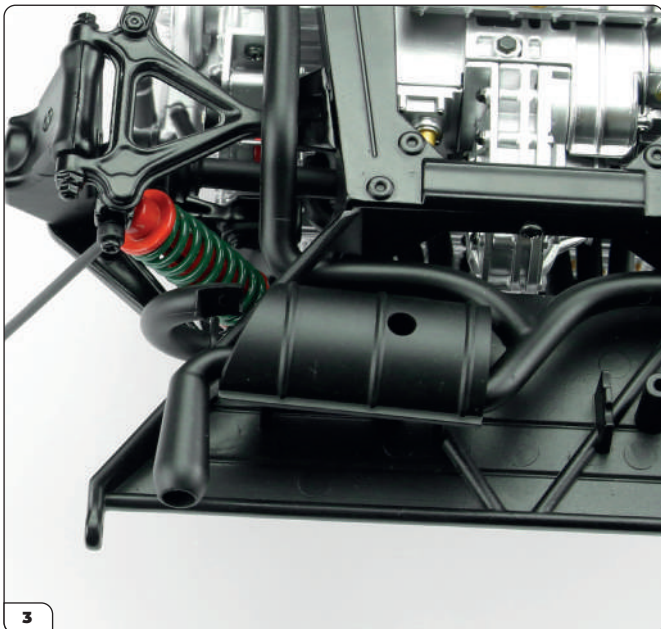

Now place the lower part of the right silencer onto the upper part as shown.

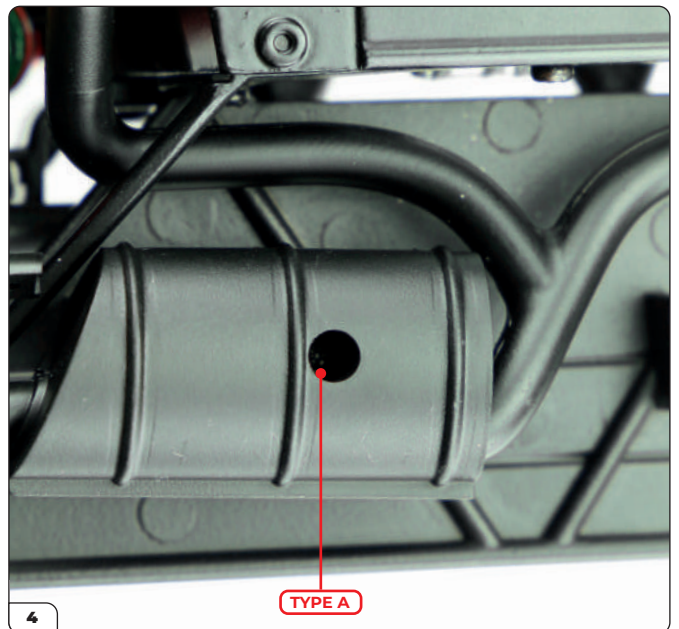

Secure the parts together by driving 1x Type A screw through the hole in the silencer.

Stage 31: Fitting the Exhaust Silencers

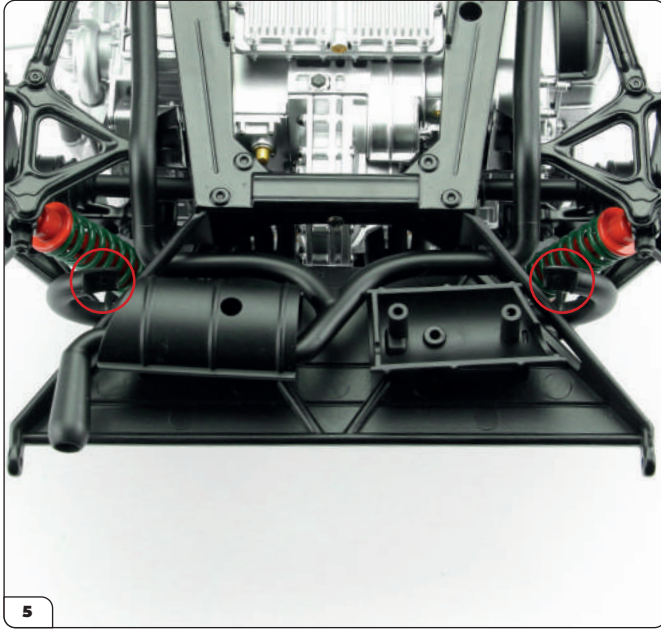

Place the left silencer (upper part) onto its support points as shown. Note the connection ends from the manifolds fitted in step 2 of stage 30 (circled).

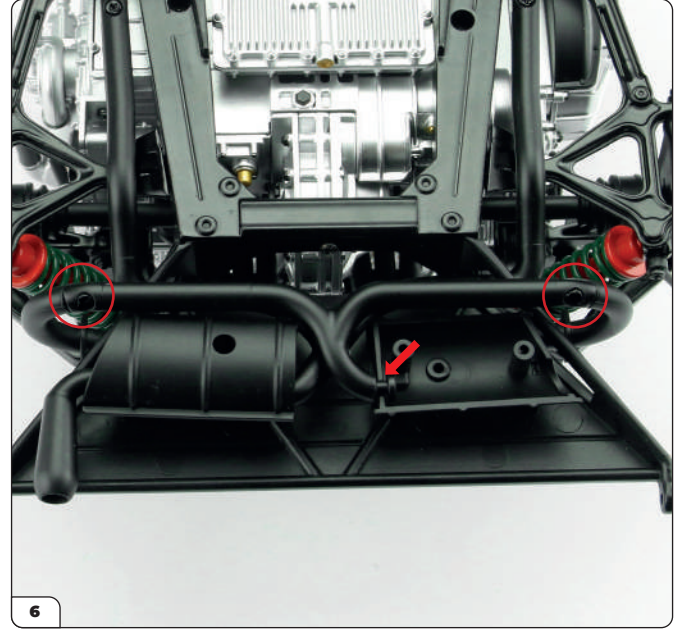

Fit the notched end of the exhaust pipe provided in this stage into the recess of the left silencer (arrow). At the same time, fit the other ends of the pipe into the ends of the manifolds highlighted in the previous step (circled).

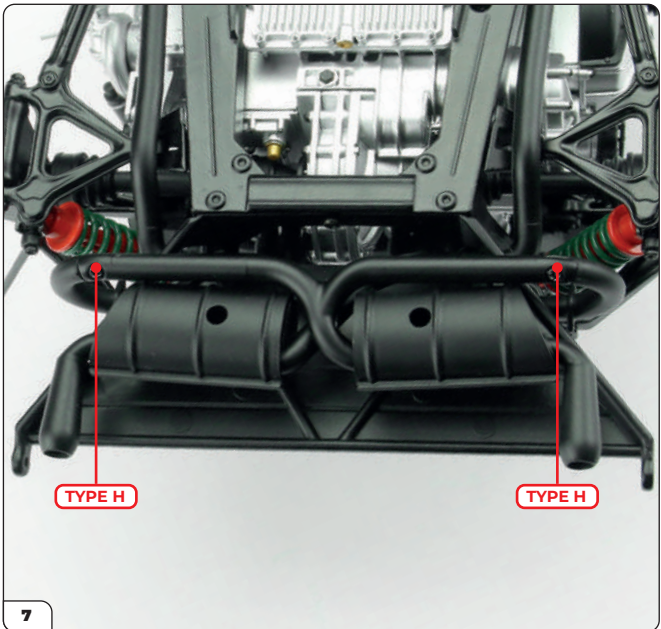

Secure the connection pipe using 2x Type H screws. Place the lower part of the left silencer over the upper part as shown.



Secure the silencer together by driving 1x Type A screw through the hole as indicated.

Stage 31: Fitting the Exhaust Silencers

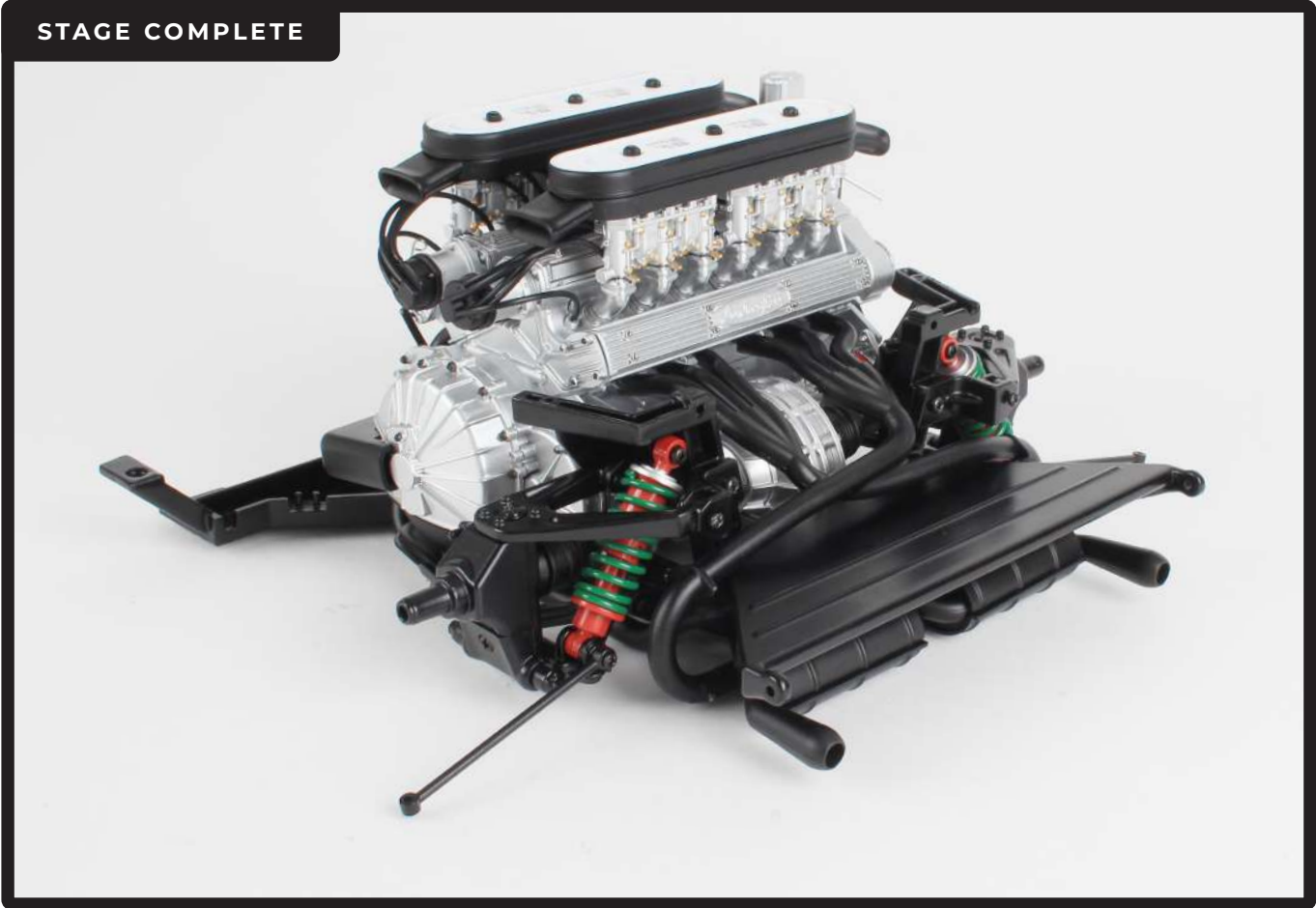

Stage 32: Attaching the Upper Frame and Fuel Filter

You'll now install the upper frame which will help to reinforce the rear of the car. The fuel filter, which is attached to the upper frame, will also be fitted in this stage.



STAGE 32 PARTS LIST

Name
Upper frame
Filter support bracket
Fuel filter
Type A screws x5

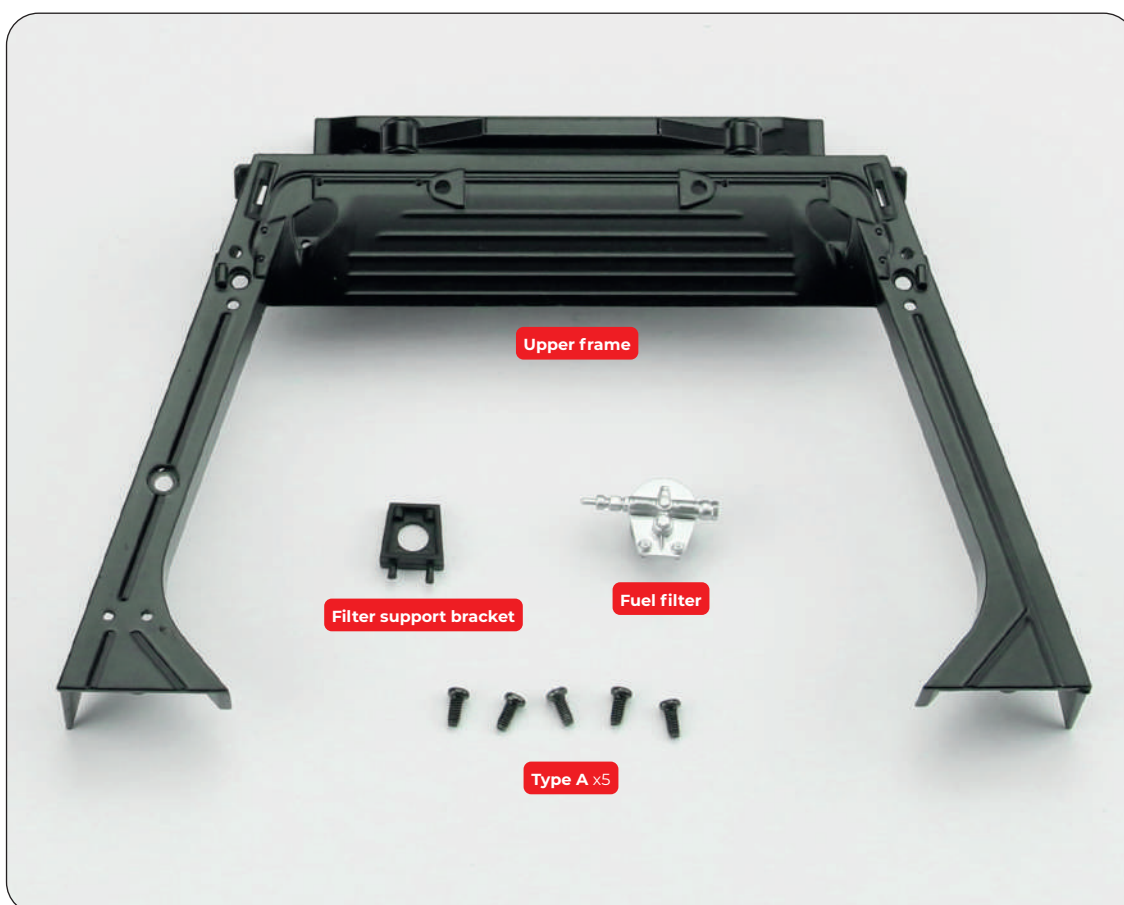

Stage 32: Attaching the Upper Frame and Fuel Filter

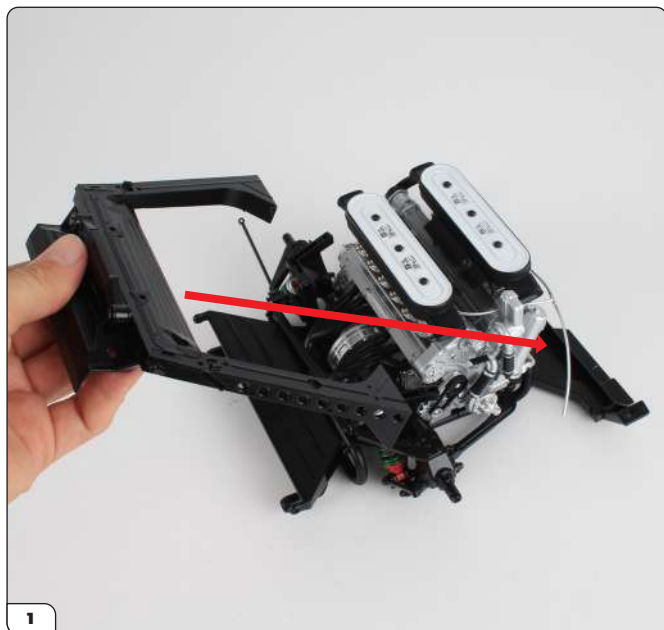

Place the rear frame assembly on your work surface. Carefully fit the upper frame over the rear frame by starting above the wishbones and move diagonally towards the rear of the engine (arrow).

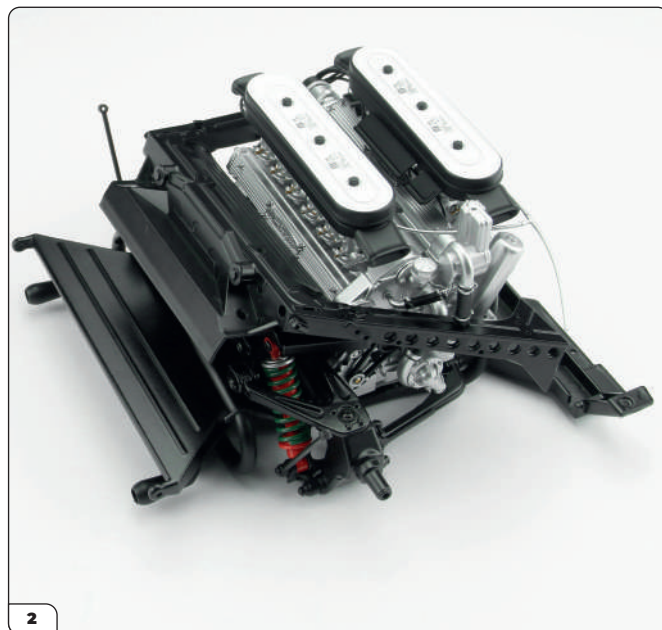

The upper frame should look like this.

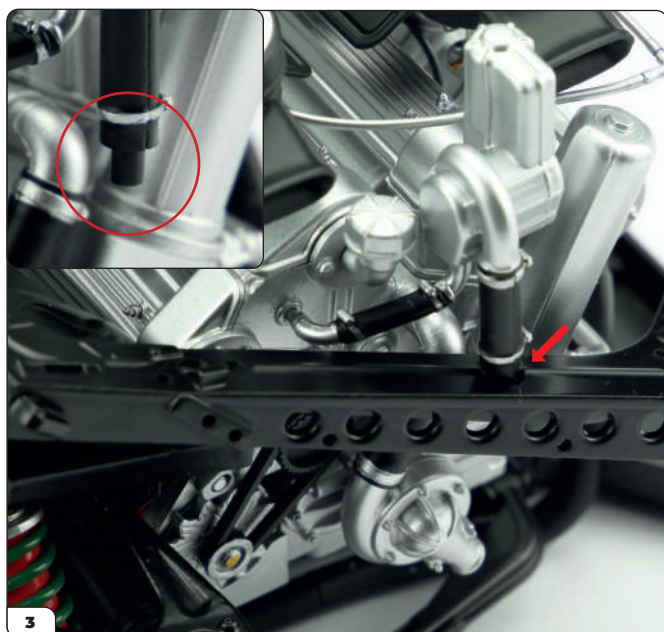

Once the upper frame is in place, fit the pin of the oil pump (inset, circled) into the corresponding hole (arrow) as shown.

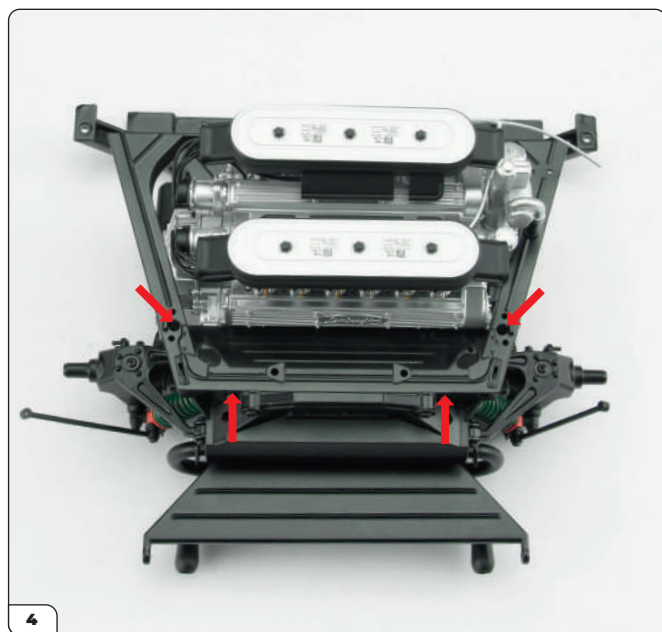

Check that the upper frame is positioned correctly on the rear frame by making sure the screw holes (arrows) are aligned properly for the next step.

Stage 32: Attaching the Upper Frame and Fuel Filter

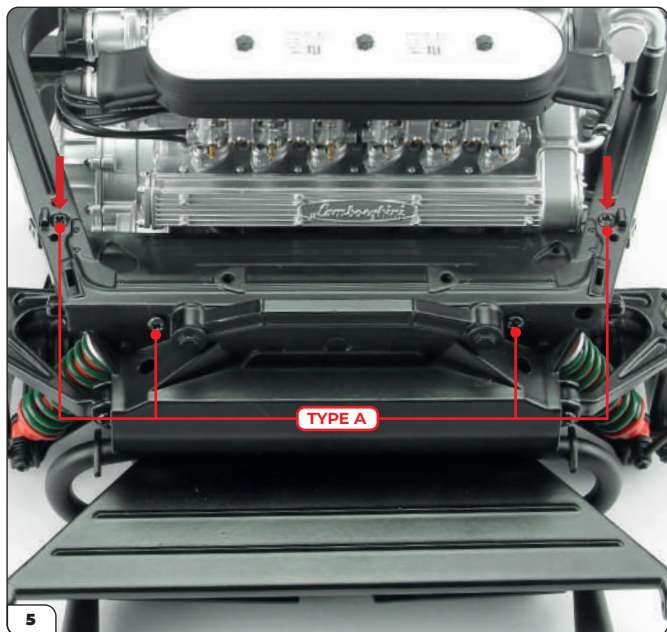

Fix the upper frame to the rear frame using 4x Type A screws. We recommend starting with the two upper screws (arrows).

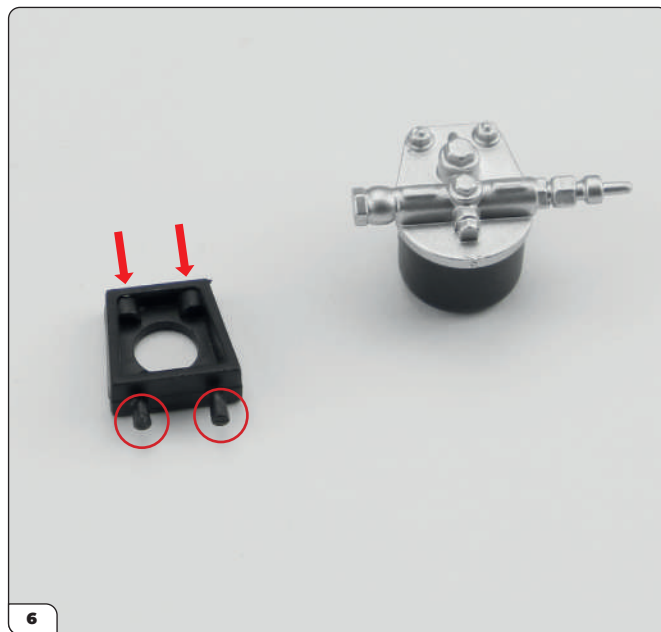

Take the fuel filter and its support bracket. Note that the bracket has two pins (circled) for fitting onto the frame and two holes (arrows) at the top to accommodate the pins of the fuel filter.

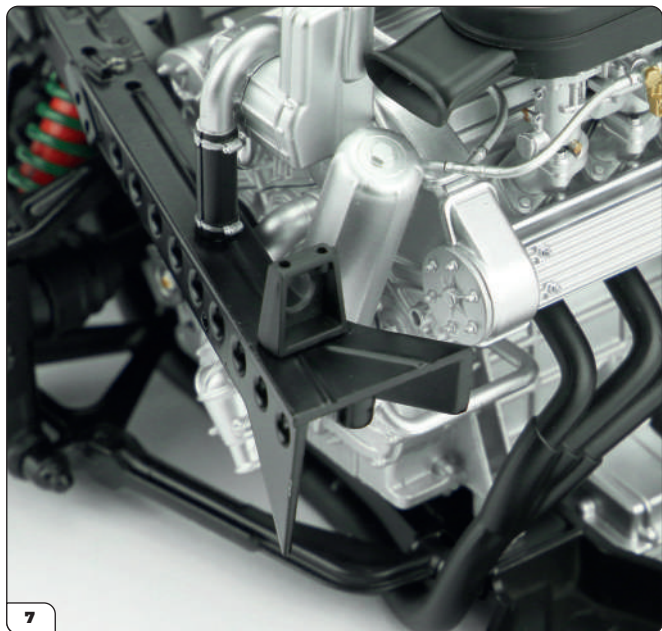

Press the filter support bracket into the two holes on the right side of the upper frame. Make sure to orient the bracket as shown.

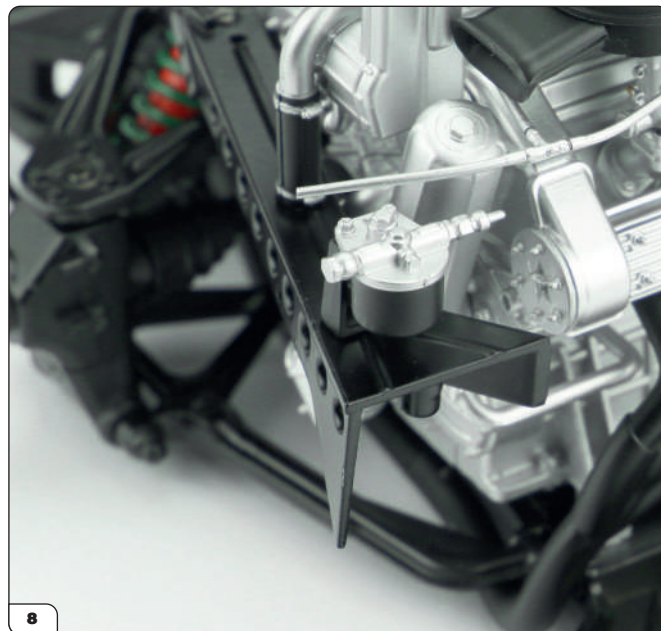

Fit the fuel filter into the bracket by pressing its pins into the holes highlighted in step 6.

Stage 32: Attaching the Upper Frame and Fuel Filter

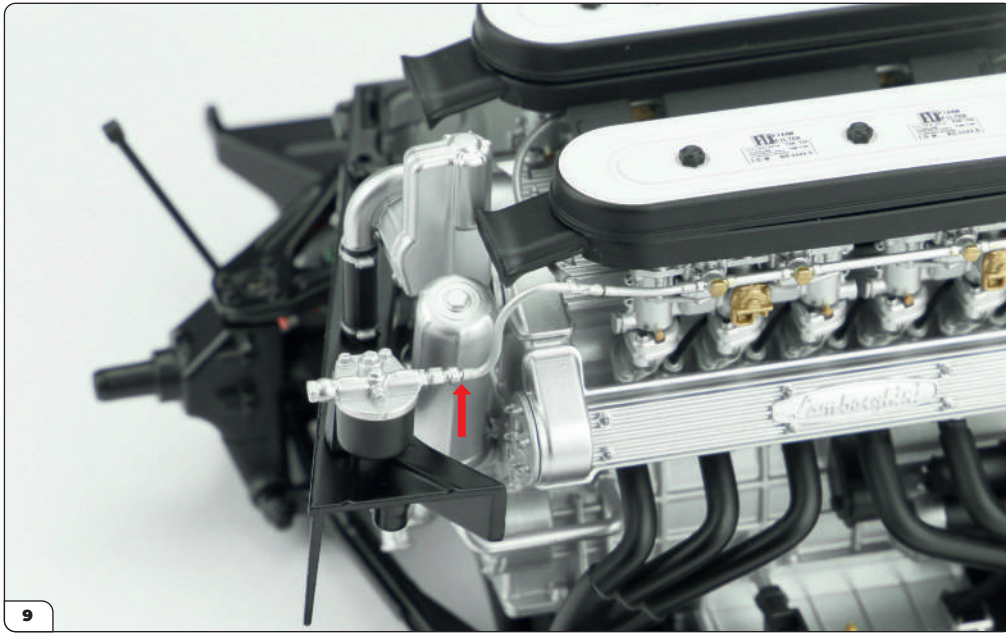

Take the loose end of the petrol pipe fitted in stage 22 and attach it to the pin on the fuel filter (arrow). You may wish to trim off some of the excess pipe length.

STAGE COMPLETE

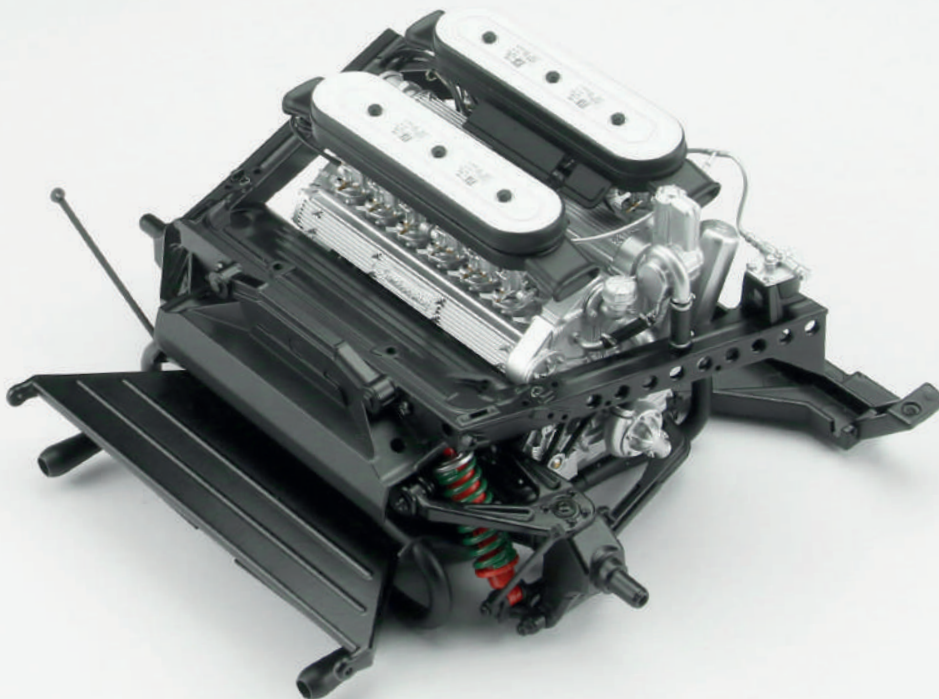

Stage 33: Fitting the Left Rear Brake Disc

In the last stage for this Pack you'll fit the first of the brake discs onto the wheel hubs, starting with the left rear one. Take care with the parts, as there is a fragile metal pin on the inner brake caliper.



STAGE 33 PARTS LIST

Name
Left rear brake disc (inner)
Left rear brake caliper (inner)
Left rear brake disc (outer)
Left rear brake caliper (outer)



Left rear brake disc (inner)



Left rear brake caliper (inner)



Left rear brake disc (outer)



Left rear brake caliper (outer)

Stage 33: Fitting the Left Rear Brake Disc

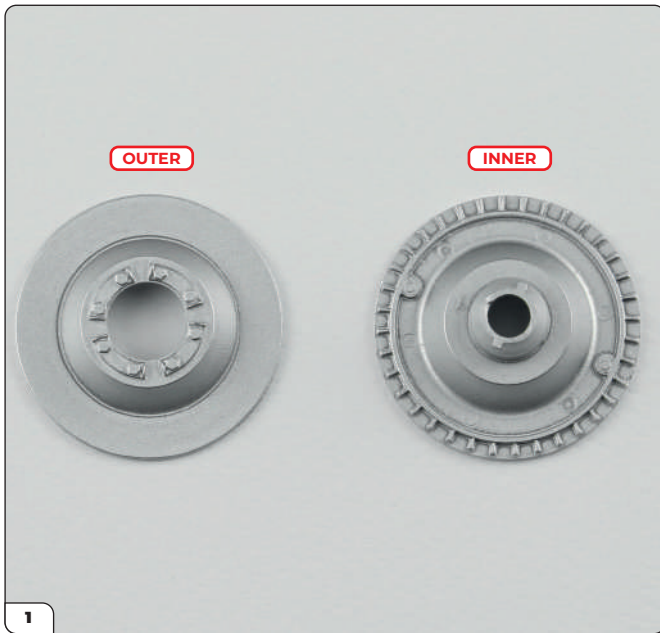

The left rear brake disc is made up of two sides. The inner side will face towards the model while the outer will face away from it. You can distinguish the two parts with the help of the image above.

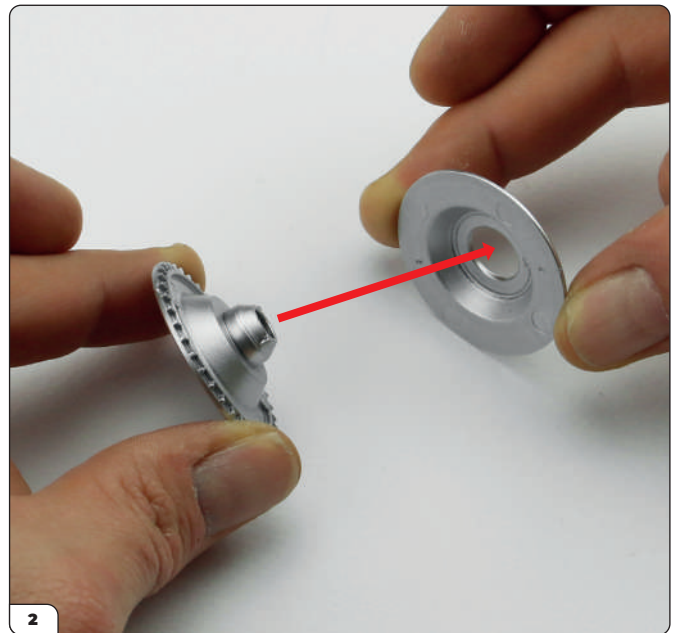

Take the inner disc and insert it into the outer disc as shown. Squeeze both parts together firmly all the way around to ensure a good fit.

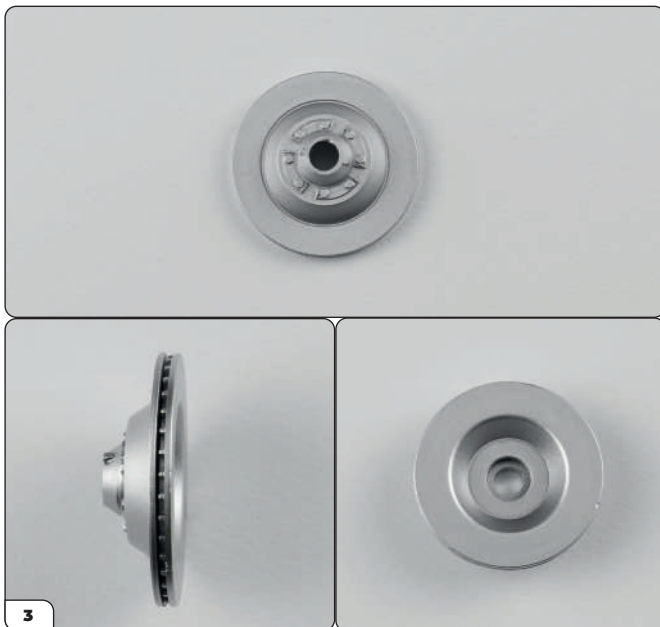

These images show the how the brake disc looks fitted together from the outside (top), in profile (bottom left) and from the inside (bottom right).



The left rear brake caliper also consists of an inner and outer part. Lay them on your work surface as shown to distinguish the two parts from each other.

Stage 33: Fitting the Left Rear Brake Disc

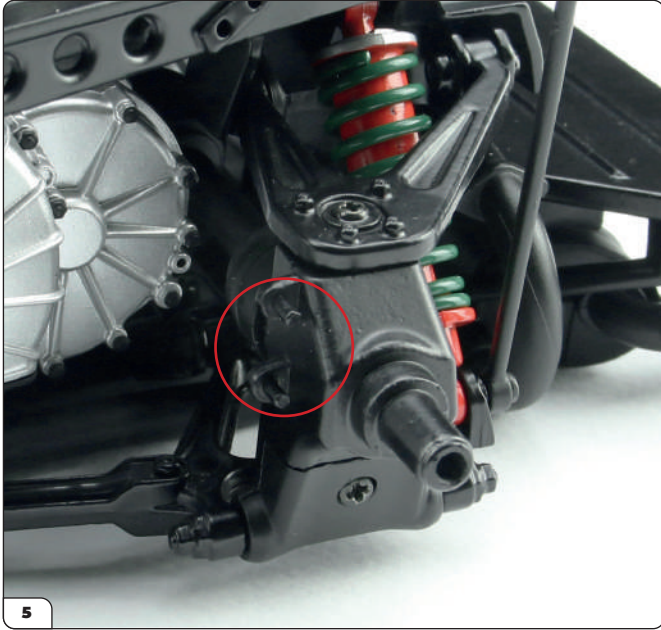

Place the rear frame assembly on your work surface. The inner part of the caliper will fit onto the two pins located next to the left rear wheel hub (circled).

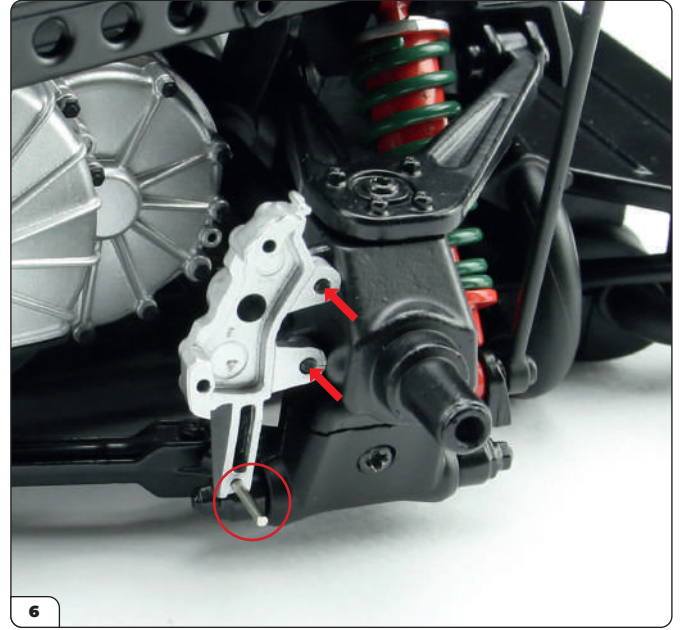

Orient the inner caliper as shown and press it onto the two pins (arrows). Take care not to apply any pressure to the thin metal pin (circled) while fitting the part in place. If necessary, carefully file away some of the paint on the pins for a better fit.

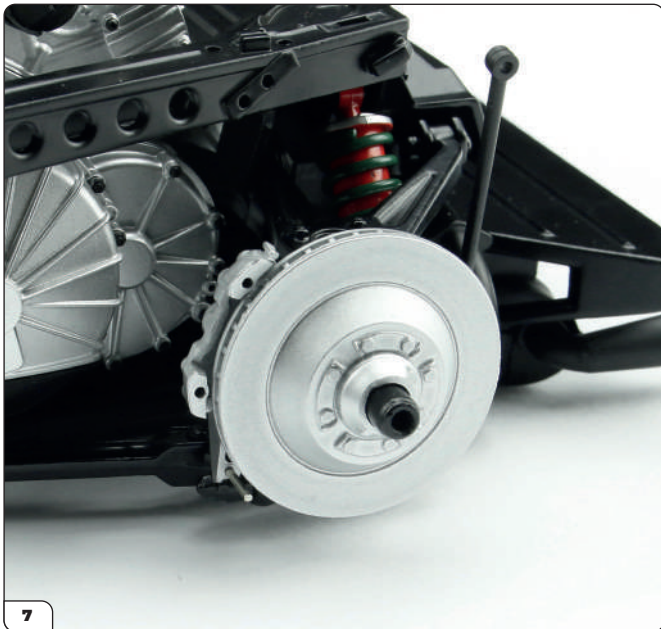

Fit the brake disc onto the wheel hub as shown.

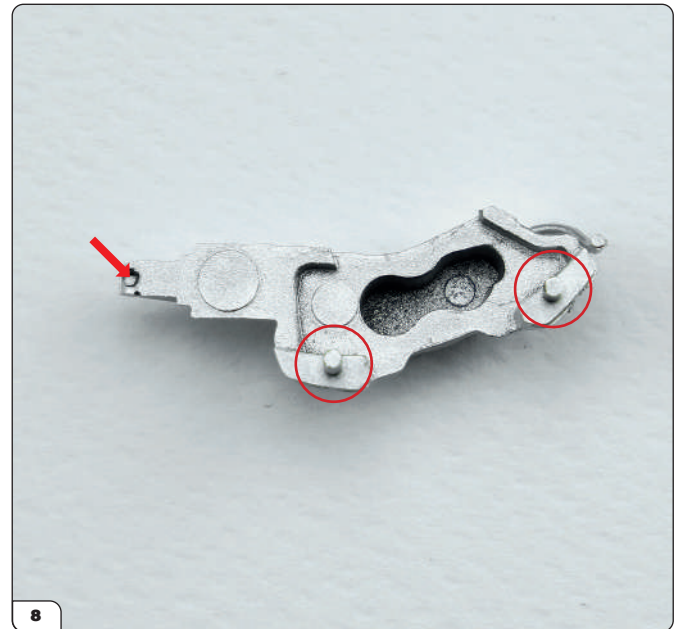

Next the outer part of the caliper will be fitted. Note the two mounting pins (circled) and the recess (arrow) that correspond with the two holes and thin metal pin of the inner caliper visible in step 7.

Stage 33: Fitting the Left Rear Brake Disc

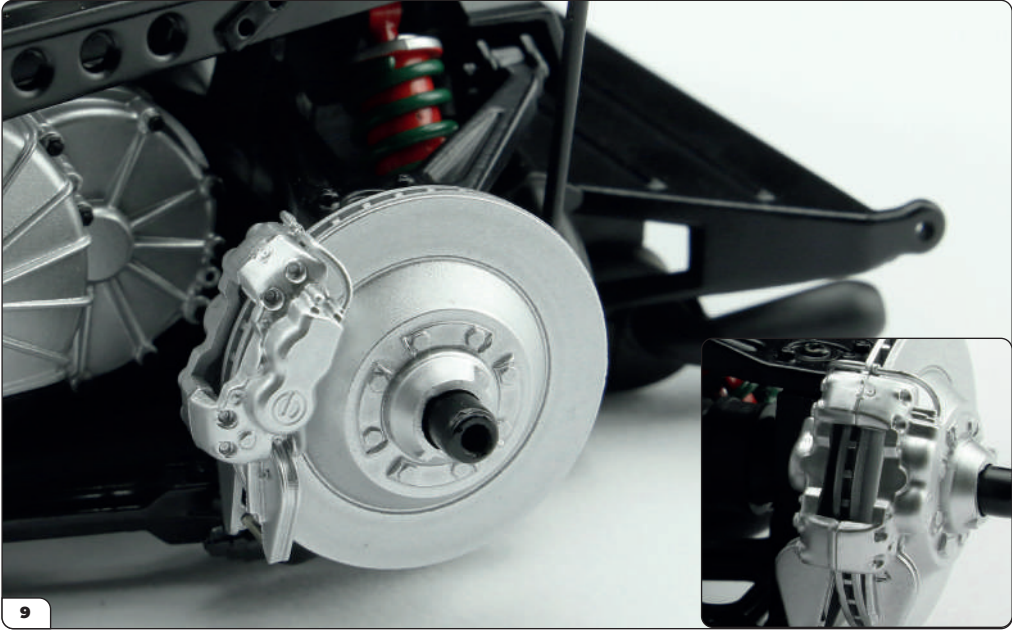

Carefully fit the outer caliper onto the inner caliper and lightly press the parts together. Check the alignment of the two halves is correct as shown in the inset image.

