



Lamborghini MIURA



Pack 09

BUILD INSTRUCTIONS

**STAGE 67: FITTING THE FRONT
BRAKE DISCS AND CALIPERS**

**STAGE 71: FITTING THE RADIATOR PIPES
AND TIE RODS**

STAGE 68: ATTACHING THE FRONT CROSSBAR

**STAGE 72: ADDING ESSENTIAL PARTS
TO THE FRAME (1)**

**STAGE 69: INSTALLING THE TANK TUBE
AND FITTING THE BRAKE AND CLUTCH
MASTER CYLINDERS**

**STAGE 73: ADDING ESSENTIAL PARTS
TO THE FRAME (2)**

**STAGE 70: ASSEMBLING AND FIXING
THE RADIATOR PANEL**

**STAGE 74: ASSEMBLING AND FITTING
THE SPARE WHEEL**

The "Automobili Lamborghini" and "Automobili Lamborghini Bull and Shield" trademarks, copyrights, designs and models are used under license from Automobile Lamborghini S.p.A, Italy.

Advice from the experts

Spare screws are included with each part. Occasionally, you may be instructed to keep spare or unused screws for a later stage. Keep these spares in a safe place and label them correctly.

Please make sure you don't mix up the screws. They look quite similar, but the threads do vary slightly. Using the wrong screws may damage the parts.

When securing parts together using multiple screws, fit each screw loosely to ensure all the parts are correctly aligned before gently tightening them firmly, but not overtight, in the order in which you placed them.

The screwdriver can be magnetized by stroking it with a magnet (fridge magnet, etc.) enabling it to hold the screws and make assembly easier.

If a screw is tight going into a metal part, do not force it as you may shear the head off. Remove it and put a tiny smear of Vaseline, soap or light oil on the thread. That will lubricate it and make it easier to drive home.

During the course of this build, you will receive many pieces that you will assemble immediately – following the instructions in the corresponding stage – and other pieces that you should store safely to one side, for use in future assembly stages.

Left and Right! When building your Lamborghini, the left or right hand side refers to each side as you are sitting in the car.



WARNING: Some parts are assembled using magnets. These magnets can cause serious injury if they are swallowed. Keep away from children. If you suspect a magnet has been swallowed, seek medical help straight away.

Stage 67: Fitting the Front Brake Discs and Calipers

In the first stage of this pack, you'll assemble the front right brake disc, then fit both brake discs to the wheel hubs.

The parts supplied with this stage will be used later, they can be stored away safely for now.



STAGE 67 PARTS LIST

Name
Front crossbar
Fuse box
Battery disconnect switch
Relay box
Type A screws x3

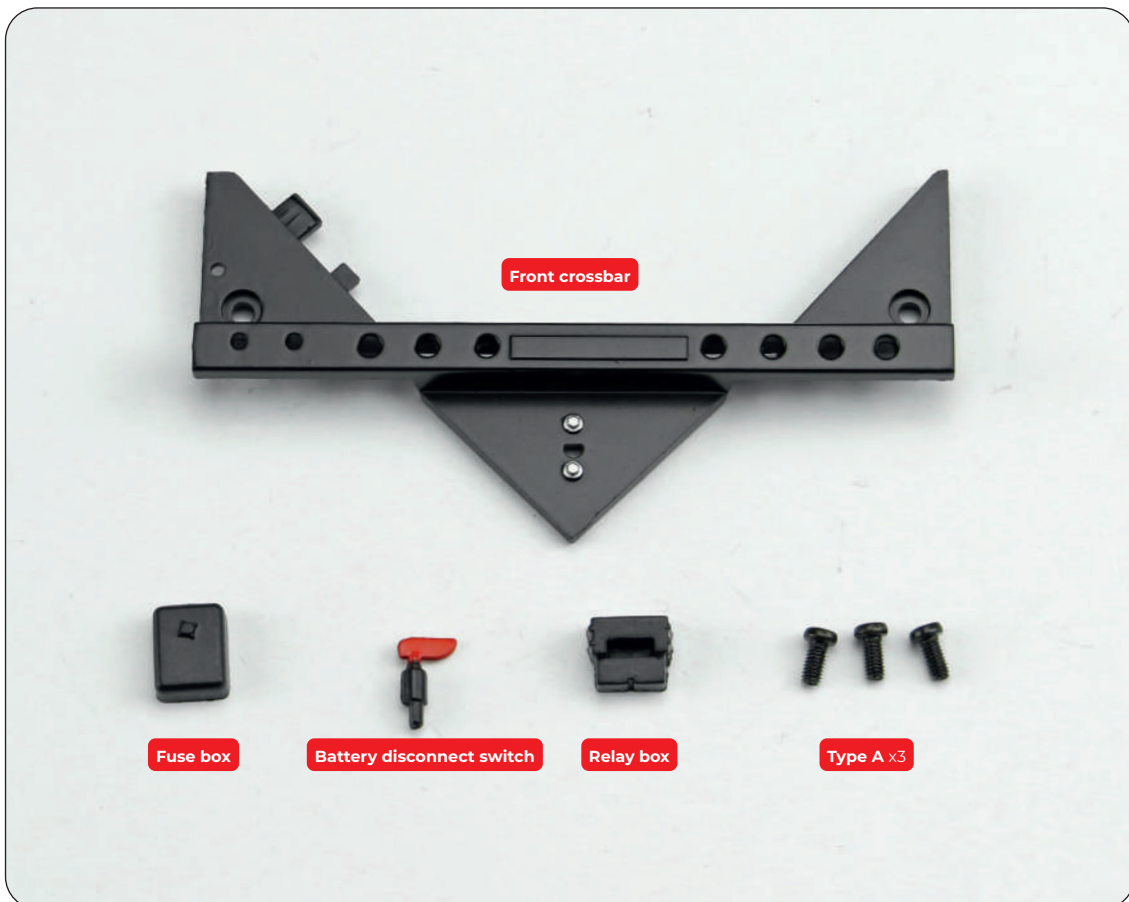

Stage 67: Fitting the Front Brake Discs and Calipers

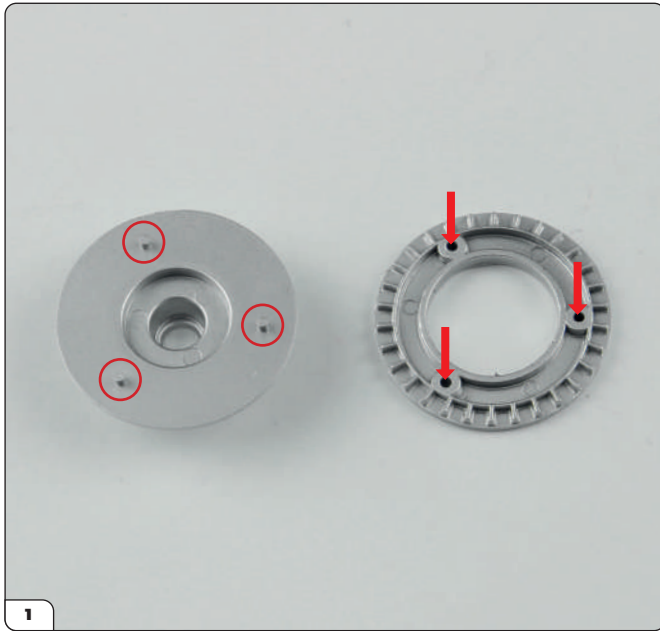

Take the two halves of the front right brake disc that were supplied in Stage 66. The external part has three pins (circled) while the internal part has three corresponding holes (arrows).



Press the pins into the holes which were highlighted in the previous step. Check that the fit is flush all the way round the brake disc.

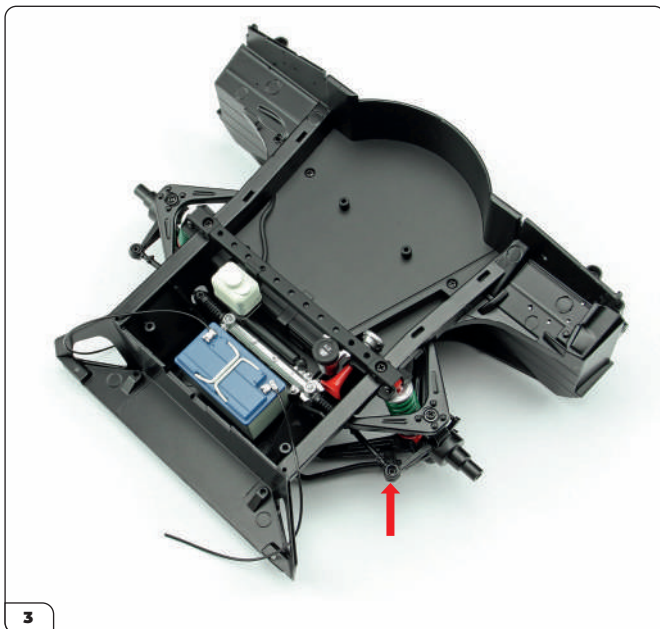

Retrieve the front frame assembly and place it on your work surface as shown. Note the steering arm connected to the wheel hub (arrow).

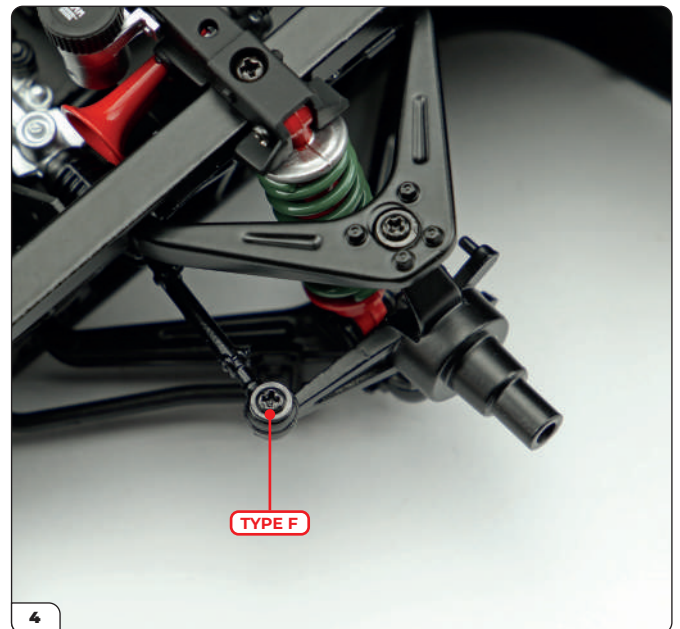

Use a Type F screw (supplied with Stage 60) to fix the left steering arm to the wheel hub.

Stage 67: Fitting the Front Brake Discs and Calipers

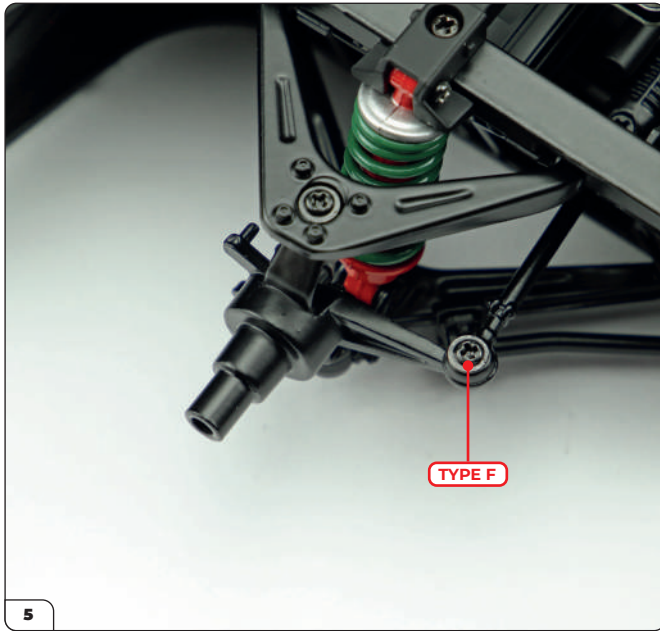

On the other side of the assembly, use another Type F screw (supplied with Stage 61) to fix the right steering arm to the wheel hub in the same manner.

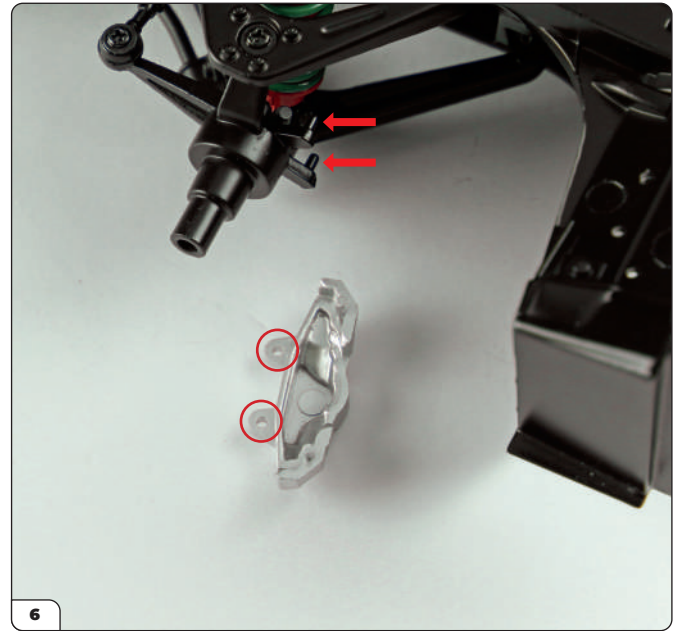

Take the front left brake caliper (inner) supplied with Stage 64. The two holes on the brake caliper (circled) fit over the two pins found on the front left hub (arrows).

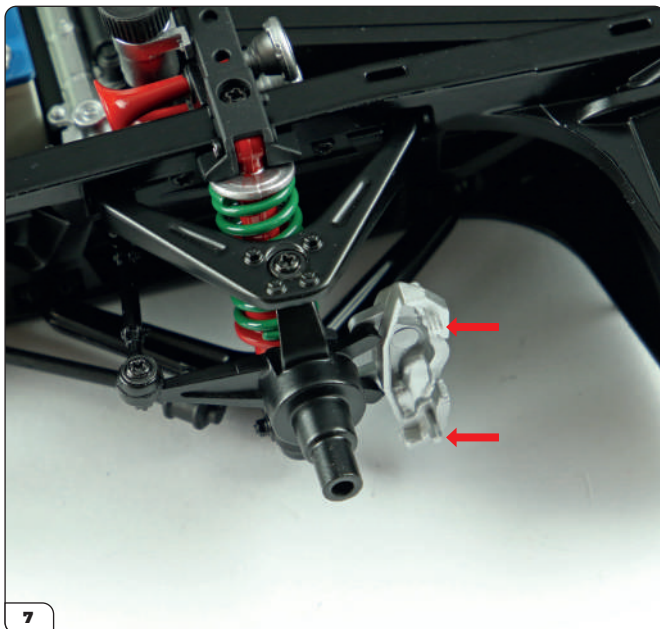

Fit the brake caliper onto the wheel hub. The silver pins on the caliper (arrows) should be facing outwards.

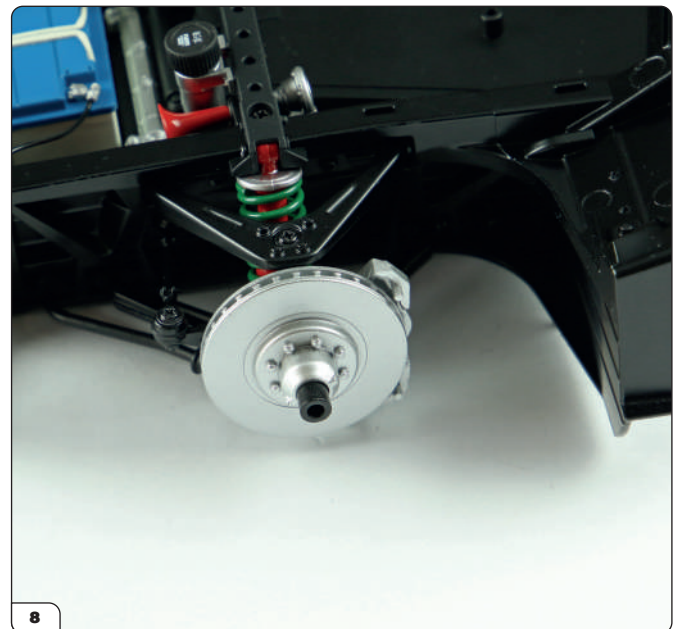

Fit the front left brake disc (assembled in Stage 64) onto the wheel hub as shown.

Stage 67: Fitting the Front Brake Discs and Calipers

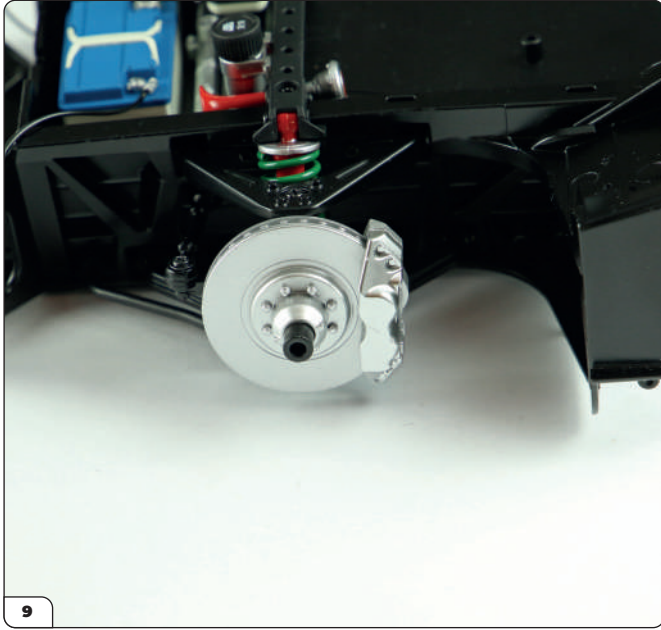

Now take the front left brake caliper (outer) supplied in Stage 64 and firmly press it onto the silver pins of the inner half.

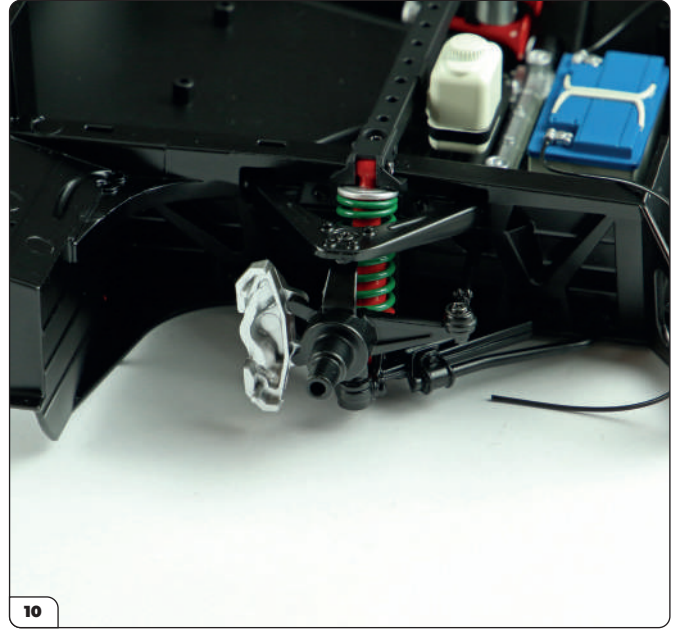

Next you'll repeat steps 6 to 9 for the right side. First fit the front right brake caliper (inner) supplied with Stage 66 onto the front right wheel hub in the same manner as before.

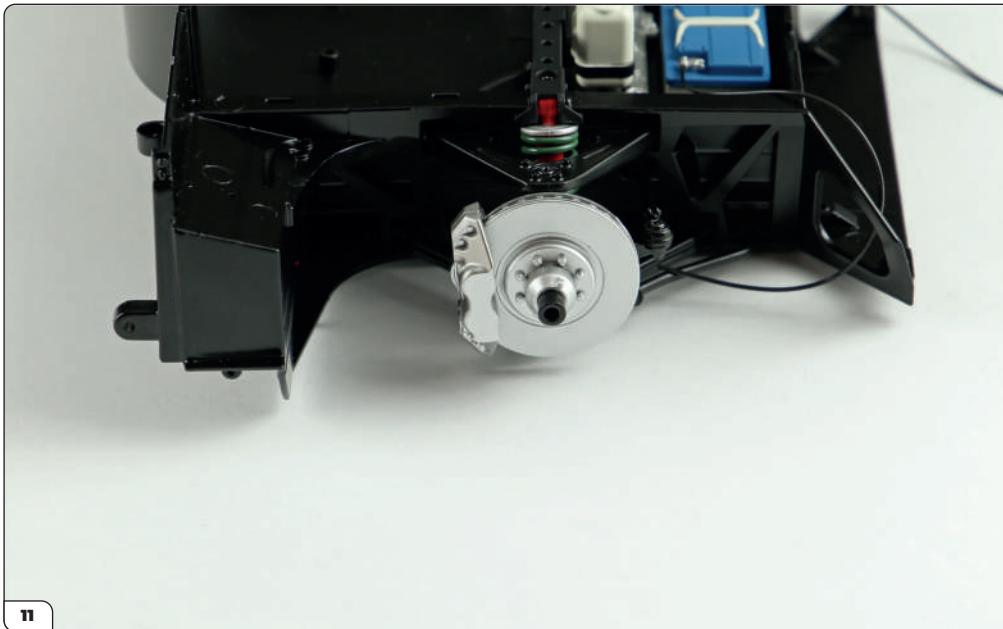

Push the front right brake disc (assembled in the first two steps of this stage) onto the wheel hub. Once in place, press the front right brake caliper (outer) from Stage 66 onto the silver pins of the inner half.

Stage 67: Fitting the Front Brake Discs and Calipers

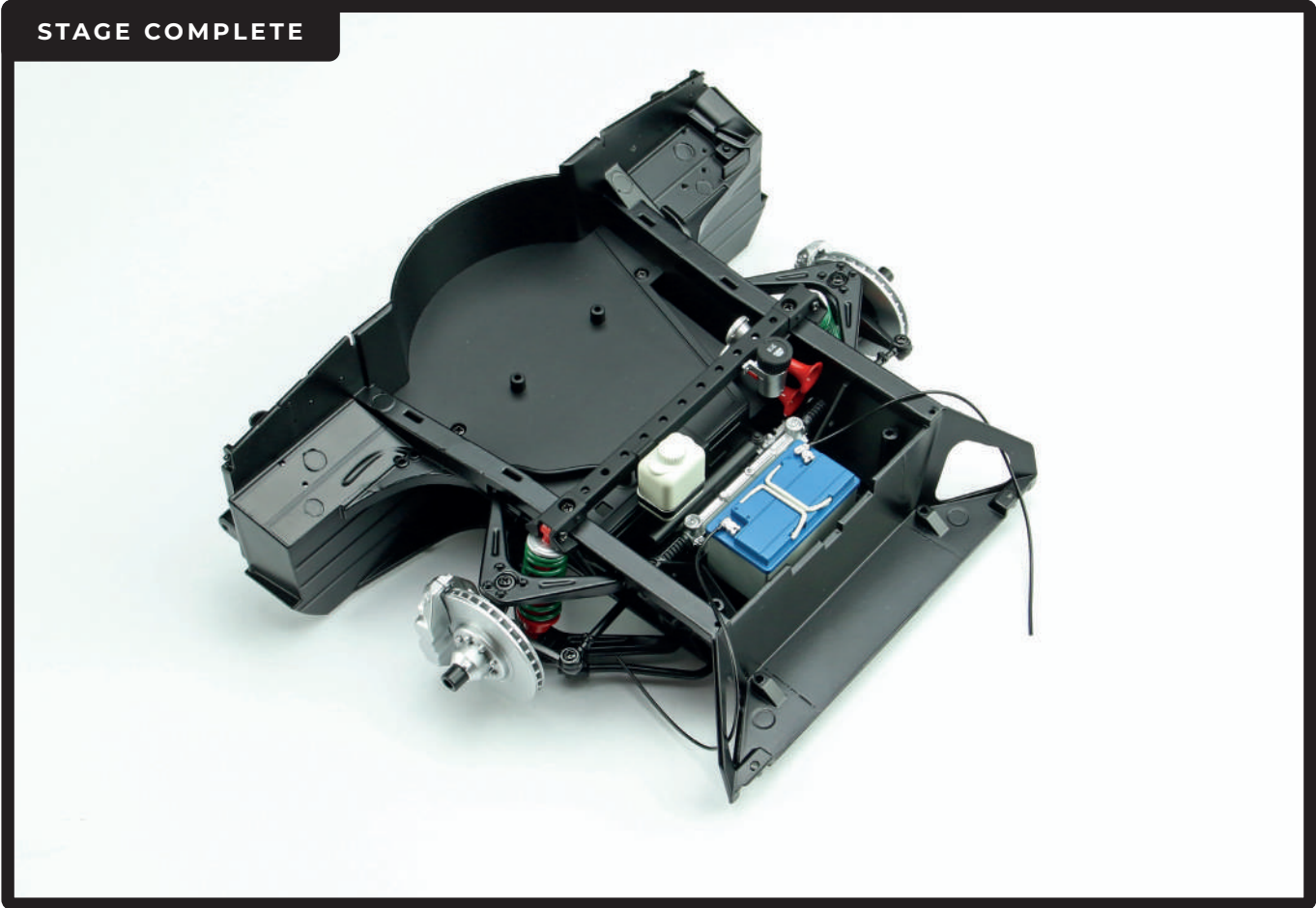

Stage 68: Attaching the Front Crossbar

For this stage you'll assemble and fit the front crossbar onto the frame assembly. You'll also thread the battery cables through to the underside of the frame.

The parts supplied with this stage can be stored away until they are needed later.



STAGE 68 PARTS LIST

Name
Tank tube support
Tank tube
Cap cover x2
Clutch master cylinder
Tank cap
Brakes master cylinder
Type B screws x3



Stage 68: Attaching the Front Crossbar

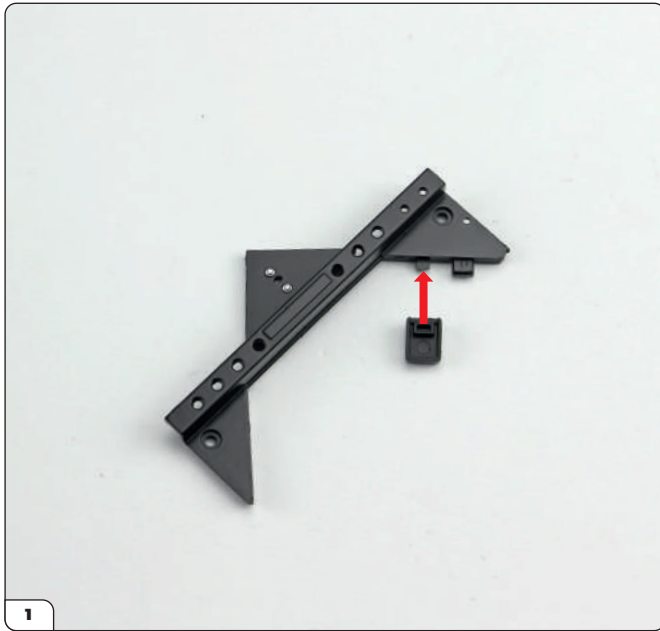

Take the fuse box along with the front crossbar supplied with Stage 67. The fuse box has a rectangular hole which fits onto the small rectangular tooth of the crossbar (arrow).



Firmly press the fuse box onto the crossbar – note the orientation of the fuse box. You may wish to file the rectangular tooth of the crossbar slightly to ensure the fuse box fits flush.

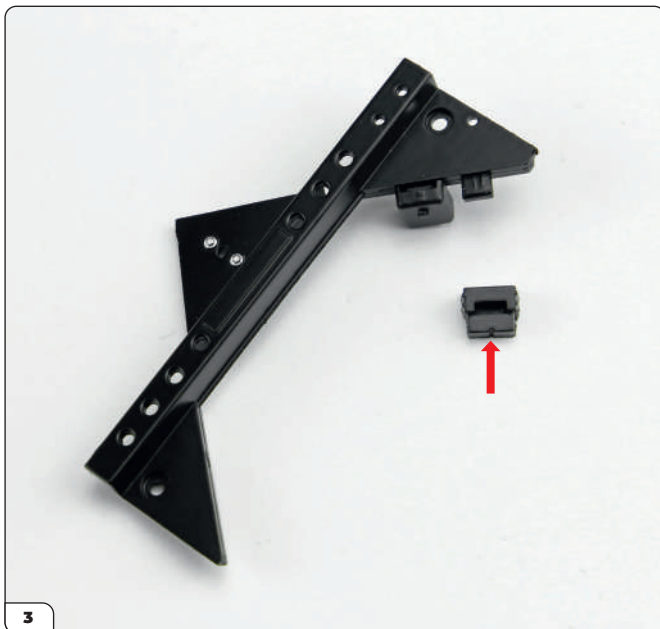

Next take the relay box supplied with Stage 67. This fits onto the crossbar in the same manner as the fuse box – note the thin notch on one side of the relay box (arrow).



Press the relay box onto the crossbar so that the thin notch is facing upwards (arrow). File the fitting if necessary so that the relay box sits flush with the crossbar.

Stage 68: Attaching the Front Crossbar

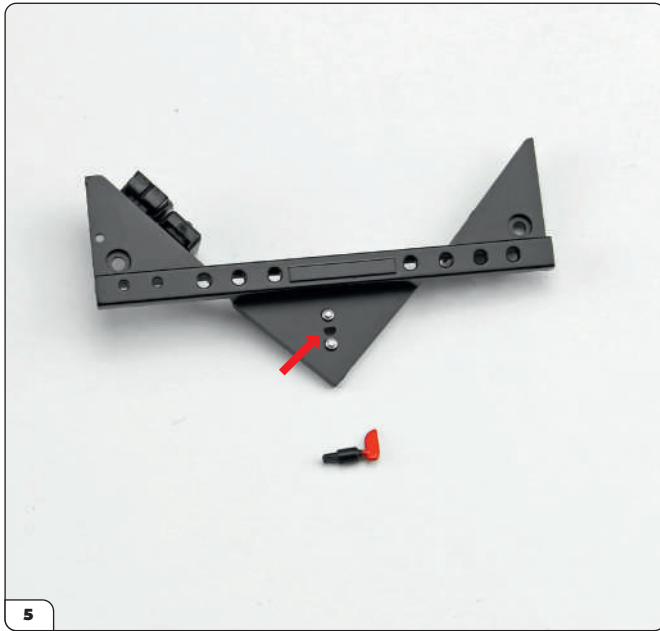

Next take the battery disconnect switch supplied with Stage 67. There is a D-shaped hole (arrow) on the crossbar for fitting this in place.



Press the battery disconnect switch into the D-shaped hole of the crossbar as shown. You may wish to use a small drop of superglue to hold the part in place.

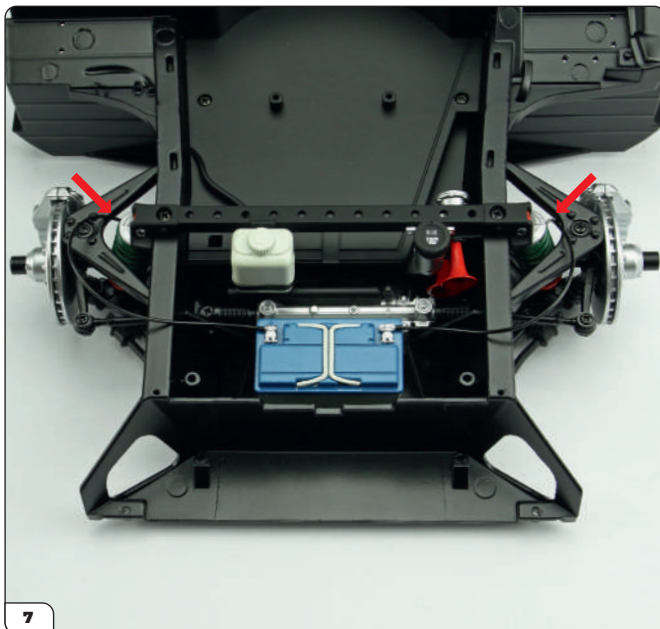

Place the front frame assembly on your work surface as shown. Locate the loose ends of the two cables connected to the battery (arrows).



Thread the loose end of each cable down the side of the battery and underneath the steering rack (arrow), towards the openings in the underside of the frame (see step 10).

Stage 68: Attaching the Front Crossbar



The cable fits between the side of the battery and the V-shaped section of the frame.

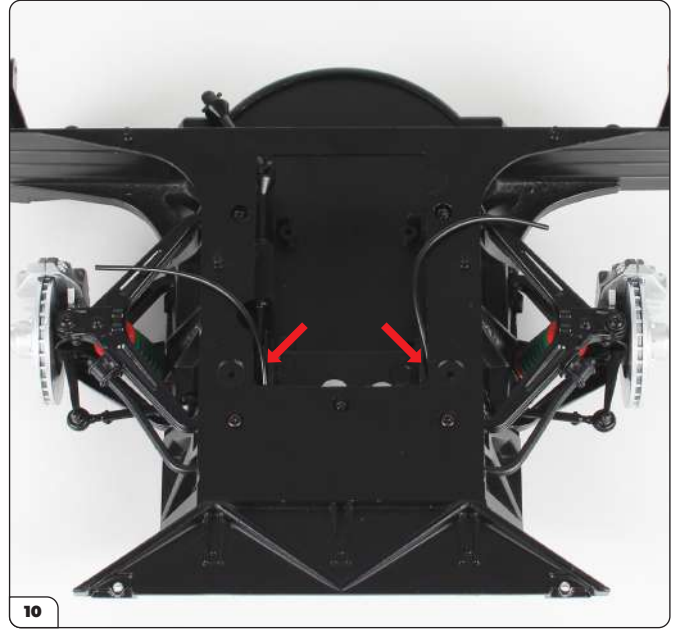

Carefully turn the assembly over and guide the ends of the cables to the openings between the frame and the cover (arrows). Push the ends of the cables through the openings.



The opening on the right side is narrow. We recommend using fine-nosed tweezers to carefully make the opening wider and allow the cable to pass through it.

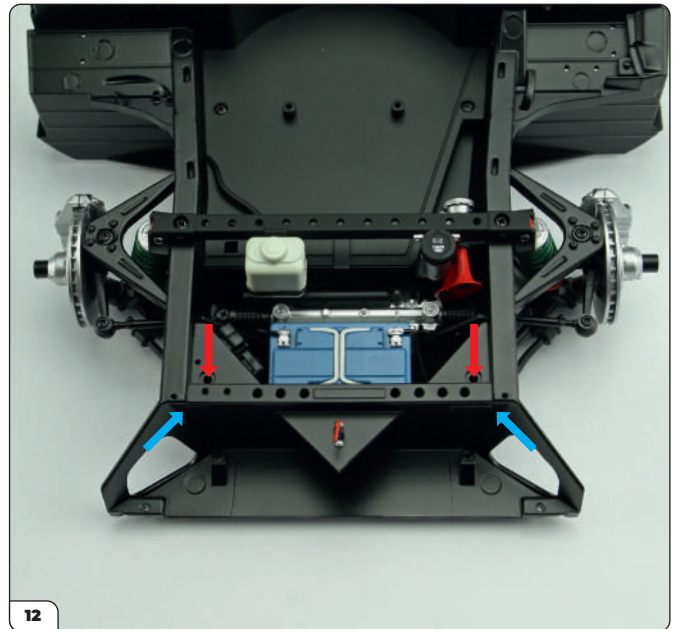

Turn the assembly back over and place the front crossbar on the frame, positioning it in front of the battery. Align the two holes of the crossbar (red arrows) to the columns on the sides of the battery. Make sure the crossbar is flush at the front (blue arrows).

Stage 68: Attaching the Front Crossbar

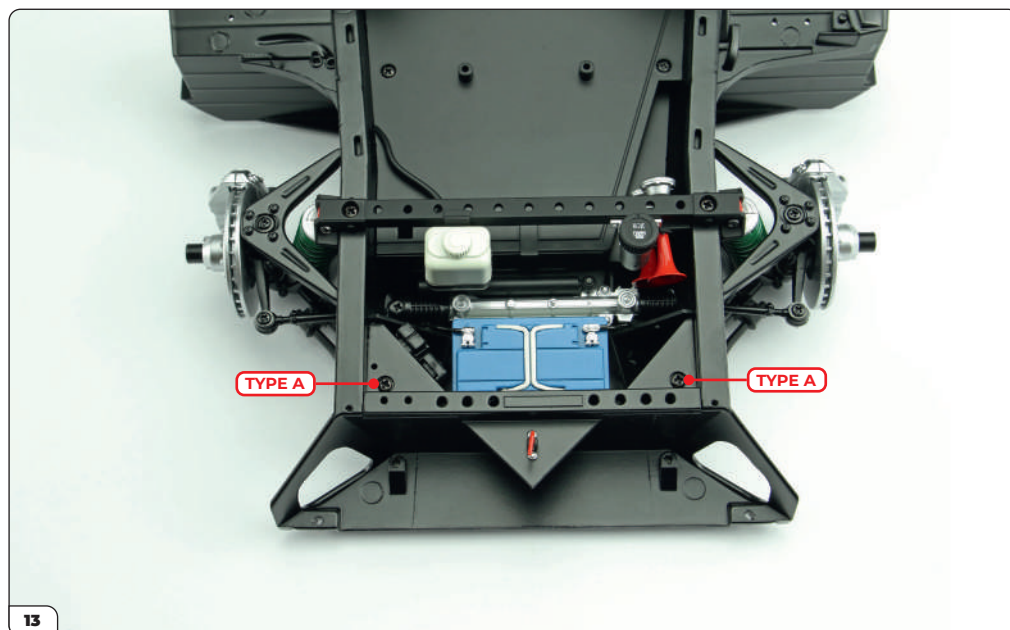

Secure the front crossbar to the frame using 2x Type A screws (supplied with Stage 67).

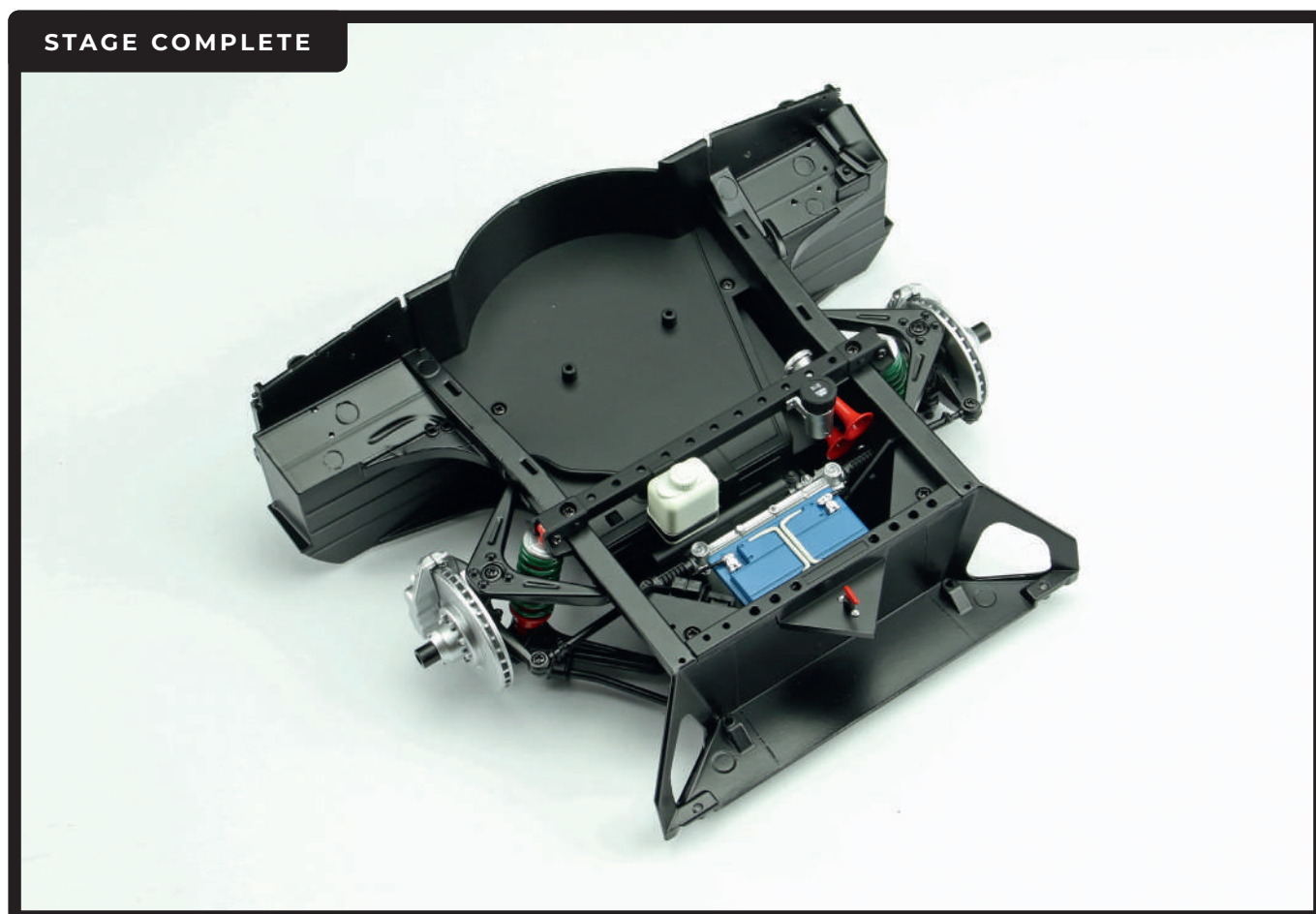

Stage 69: Installing the Tank Tube and Fitting the Brake and Clutch Master Cylinders

After assembling the tank tube, you'll fit it onto the front frame assembly. You'll also build then attach the brake and clutch master cylinders to the frame.

The parts supplied will be used in the next stage, you can store them away safely for now.



STAGE 69 PARTS LIST

Name
Lower radiator panel
Fan support grille
Cooling fan

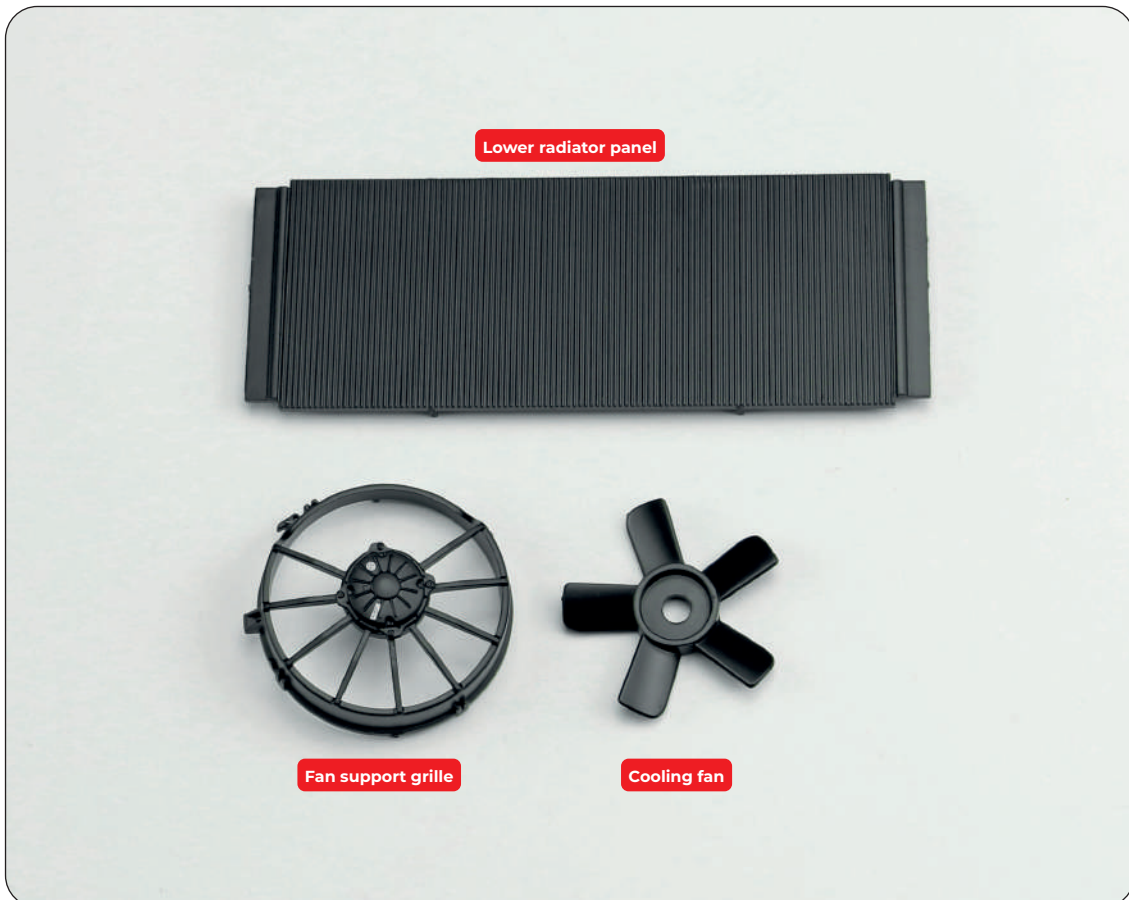

Stage 69: Installing the Tank Tube and Fitting the Brake and Clutch Master Cylinders

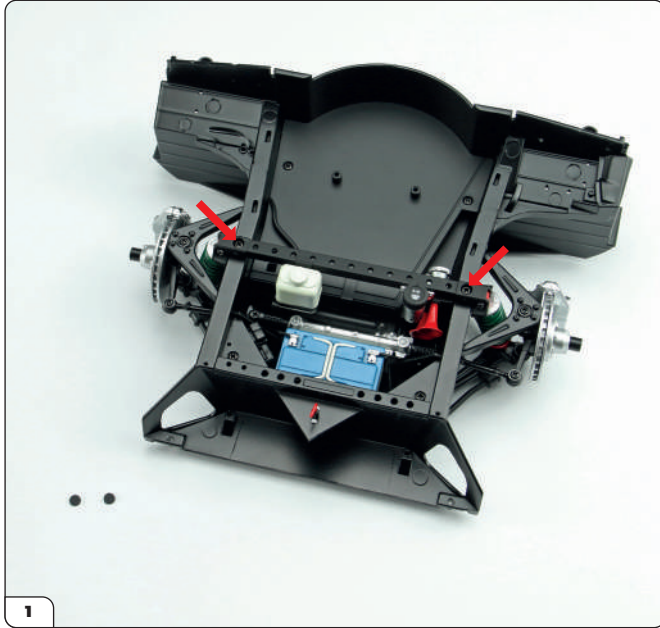

Place the front frame assembly on your work surface and take the two cap covers supplied with Stage 68. These will cover the screws highlighted by the arrows in the image.

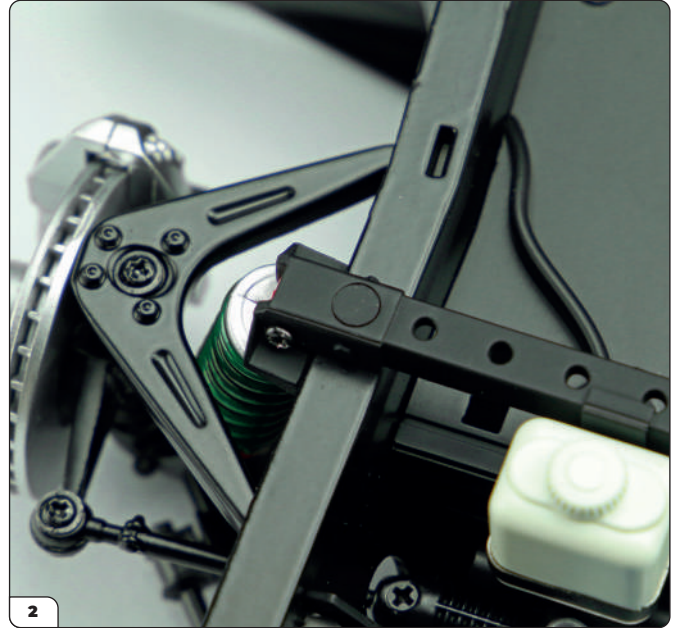

Place one of the cap covers over the screw of the crossbar in the middle of the frame as shown.

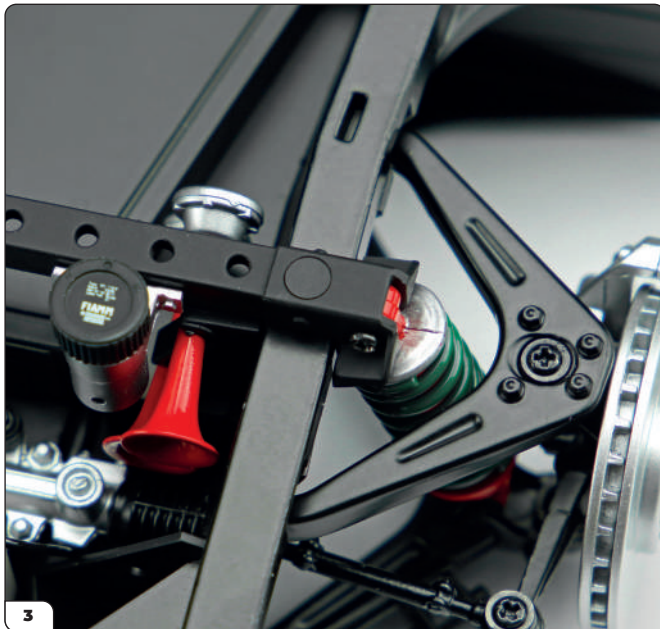

Press the other cap cover into place on the other side of the crossbar.



Take the tank tube, its support and one of the Type B screws that were all supplied with Stage 68.

Stage 69: Installing the Tank Tube and Fitting the Brake and Clutch Master Cylinders



Align the tube with the support as shown. Fit the tube into the support by positioning the screw hole of the tank tube onto the corresponding column of the support (arrow).

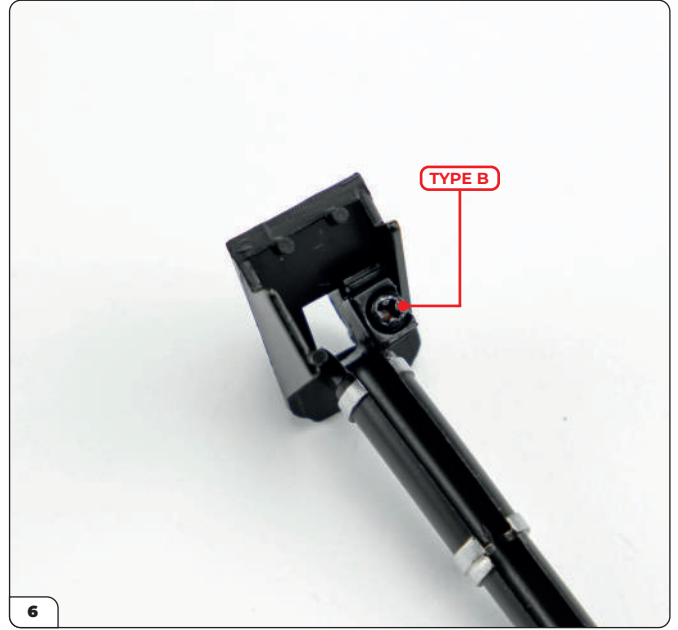

Fasten the parts together using the Type B screw.



Turn the tank tube assembly over and take the tank cap supplied with Stage 68. There are two rectangular teeth on the cap which fit into the support (circled). Press the cap in place as shown in the inset image.

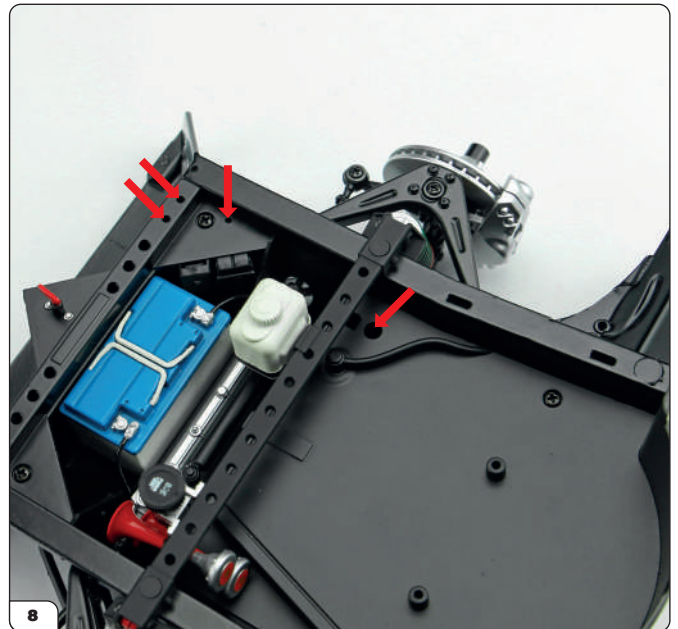

To install the tank tube on the front frame assembly, first find the holes located on the front crossbar, the triangular plate, and the frame cover (arrows).

Stage 69: Installing the Tank Tube and Fitting the Brake and Clutch Master Cylinders

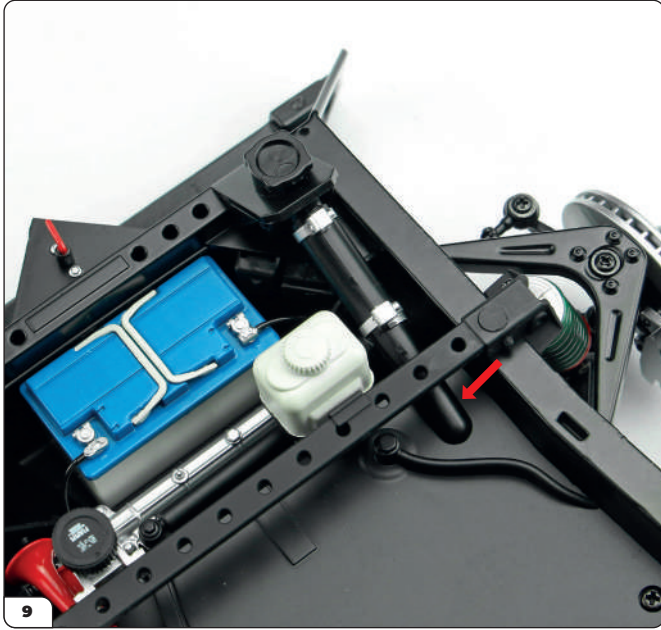

Fit the tank tube by passing it under the middle crossbar and pushing the large pin of the tube into the hole of the frame cover (arrow). Press the small pins of the tank tube support into the three corresponding holes in the front crossbar and triangular plate that were highlighted in the previous step.



Take the two master cylinder parts supplied with Stage 68. The brake cylinder has a rectangular tooth (circled) which fits into the rectangular hole of the clutch cylinder (arrow). Fit the pieces together as shown in the right image.

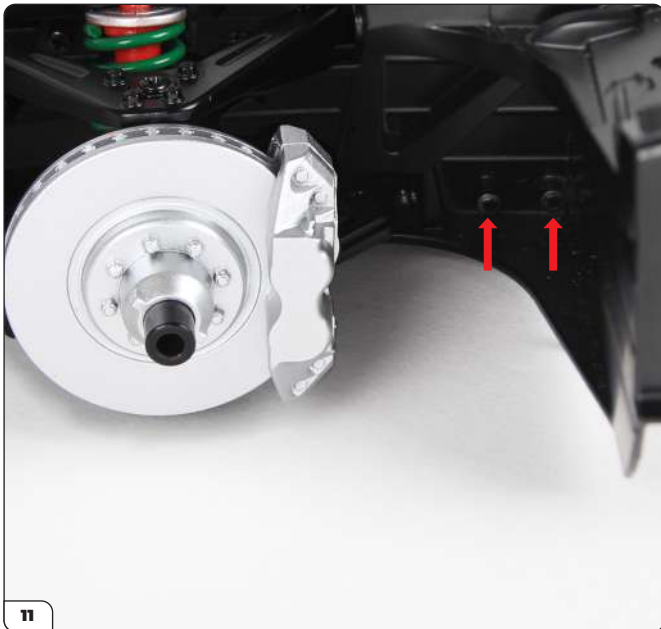

Locate the two holes (arrows) on the left side of the frame assembly, next to the front left wheel hub.

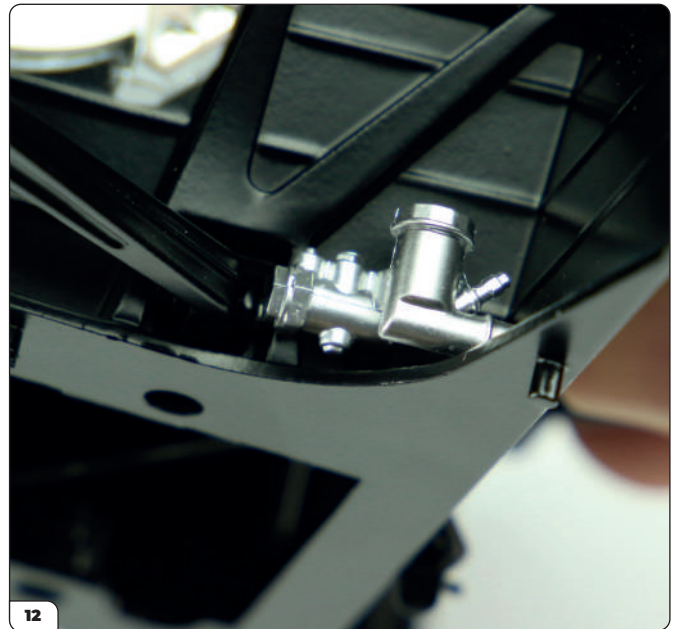

Press the two pins of the brake cylinder into the holes, orienting it as shown in the image.

Stage 69: Installing the Tank Tube and Fitting the Brake and Clutch Master Cylinders

STAGE COMPLETE

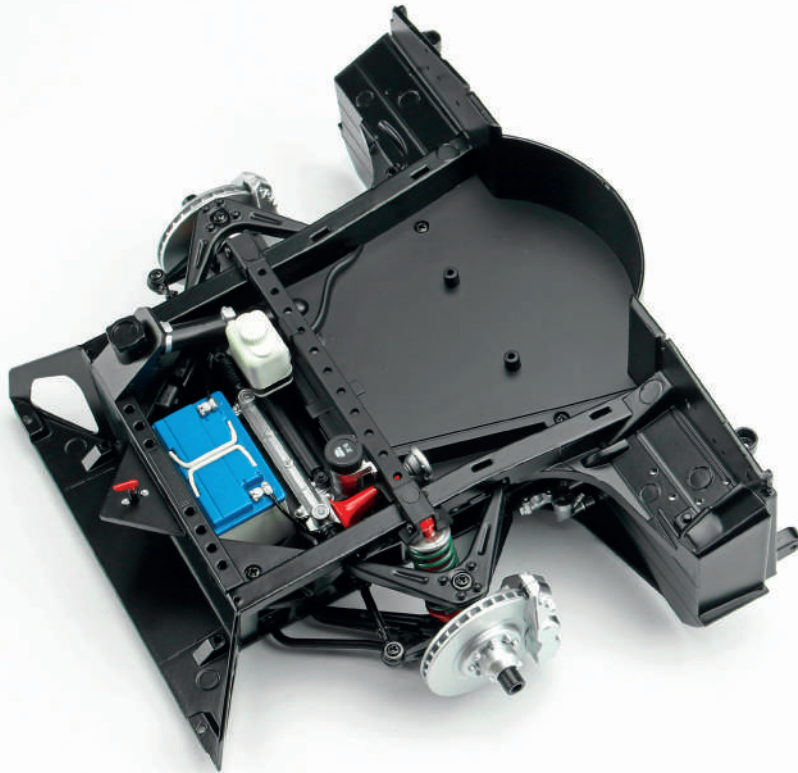

Stage 70: Assembling and Fixing the Radiator Panel

In this stage you'll assemble the radiator panel and fit it in place on the front frame assembly.



STAGE 70 PARTS LIST

Name
Upper radiator panel
Fan support grille
Cooling fan
Type B screws x3
Type S screws x3

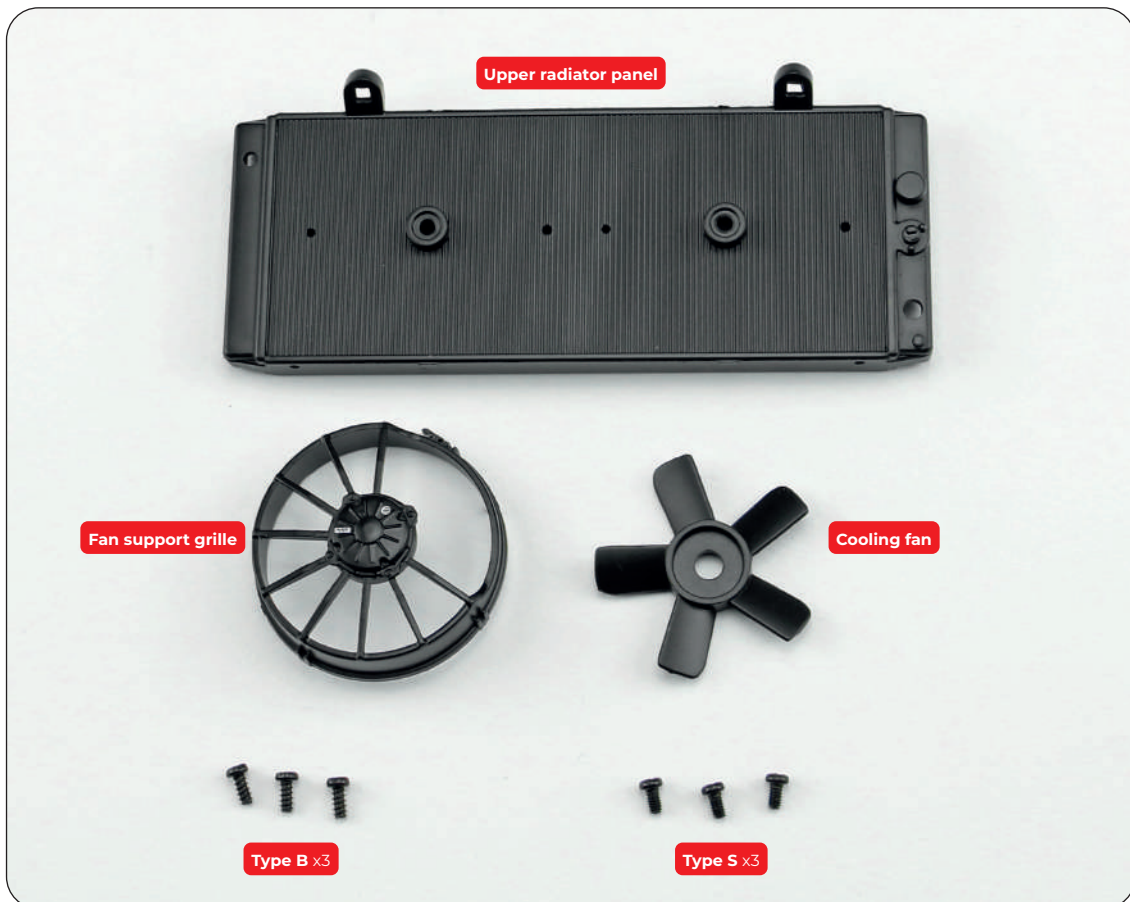

Stage 70: Assembling and Fixing the Radiator Panel

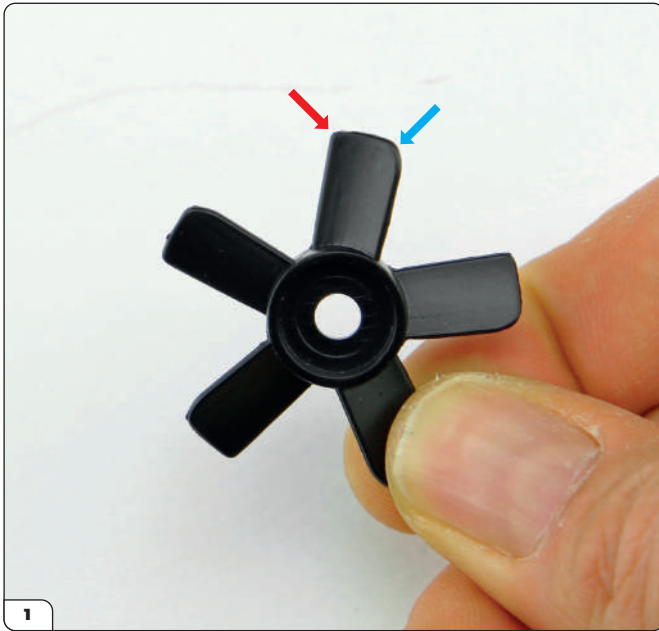

Take the cooling fans (one supplied with this stage and the other with Stage 69). Note that the blades have a sharp corner (red arrow) and a rounded corner (blue arrow).



Place the upper radiator panel on your work surface and mount the two fans onto it. Orient the fans with the sharp corners (red arrow) and the rounded corners (blue arrow) as shown. Note the four small holes (circled) for fitting the fan support grilles.



Take the two fan support grilles (one supplied with this stage and the other with Stage 69) and fit them in place over the fans by pressing their pins into the holes highlighted in step 2. The openings in the grilles (arrows) should be towards your left as shown.



Holding the fans and grilles in place, carefully turn the upper panel over. Secure the fans and grilles to the panel using 2x Type B screws.

Stage 70: Assembling and Fixing the Radiator Panel

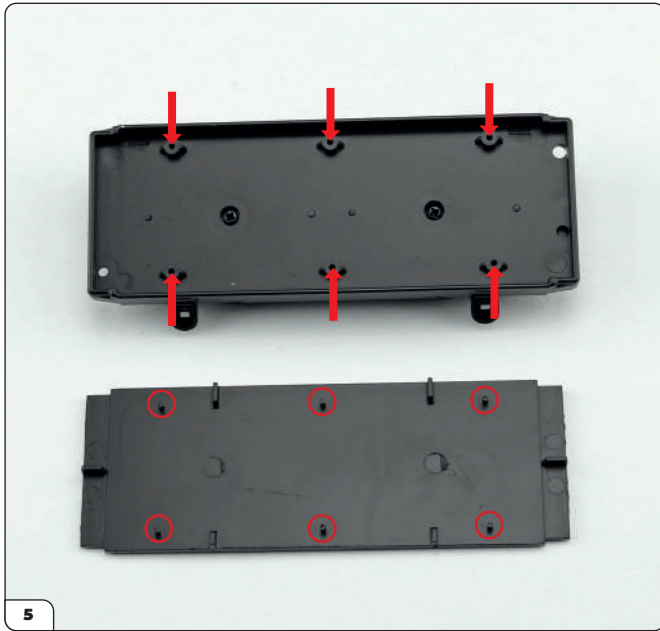

Take the lower radiator panel (supplied with Stage 69) and align it with the upper panel as shown. There are six pins (circled) on the lower panel that correspond with six holes (arrows) on the upper panel.



Press the pins of the lower panel into the holes of the upper panel.

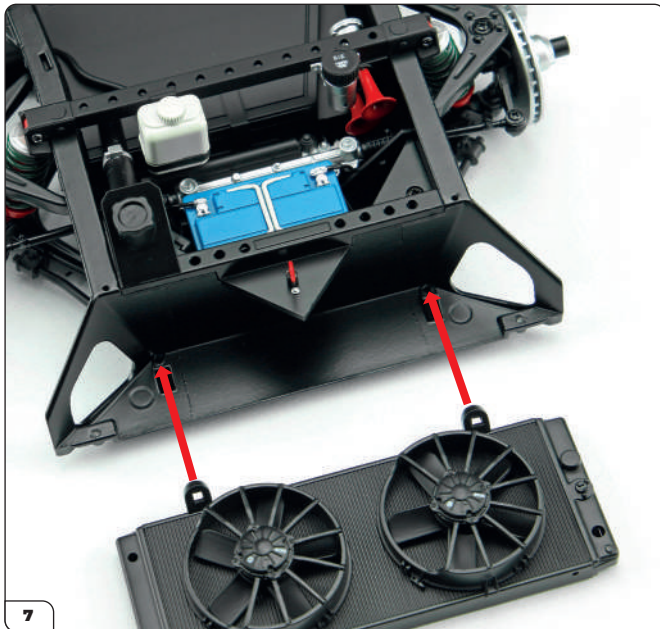

Now take the front frame assembly and align the radiator in front of it as shown, with the fans facing up. The two fixing brackets fit over the two raised screw holes located in the front part of the frame (arrows).

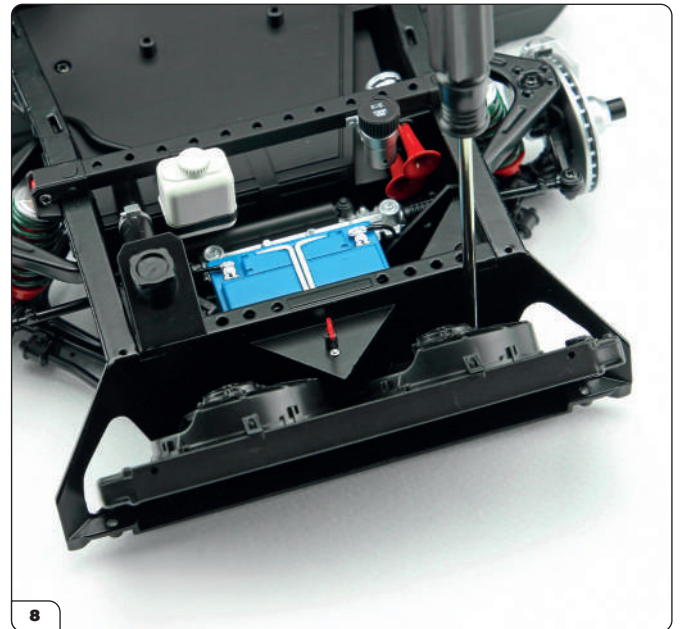

Fit the radiator onto the front frame with the fans facing inwards then secure it using 2x Type S screws (see steps 9 and 10). We recommend using a long screwdriver as shown.

Stage 70: Assembling and Fixing the Radiator Panel

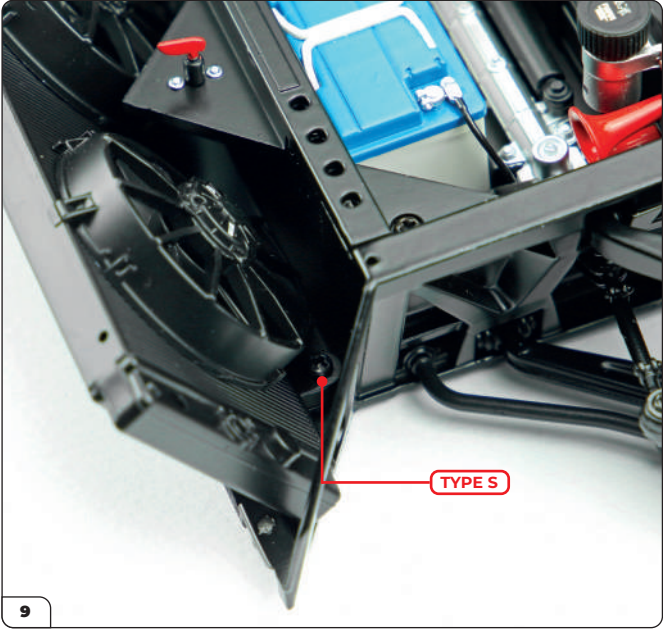

The left side of the radiator secured with a Type S screw.

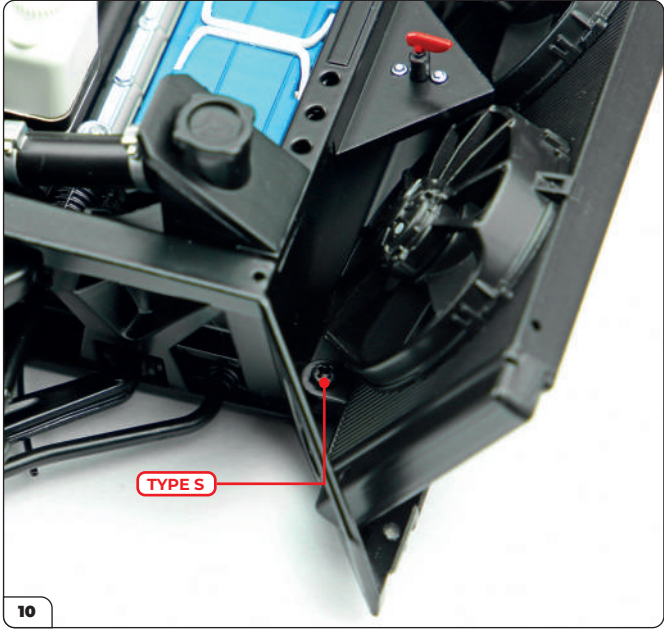

The right side of the radiator secured with a Type S screw.

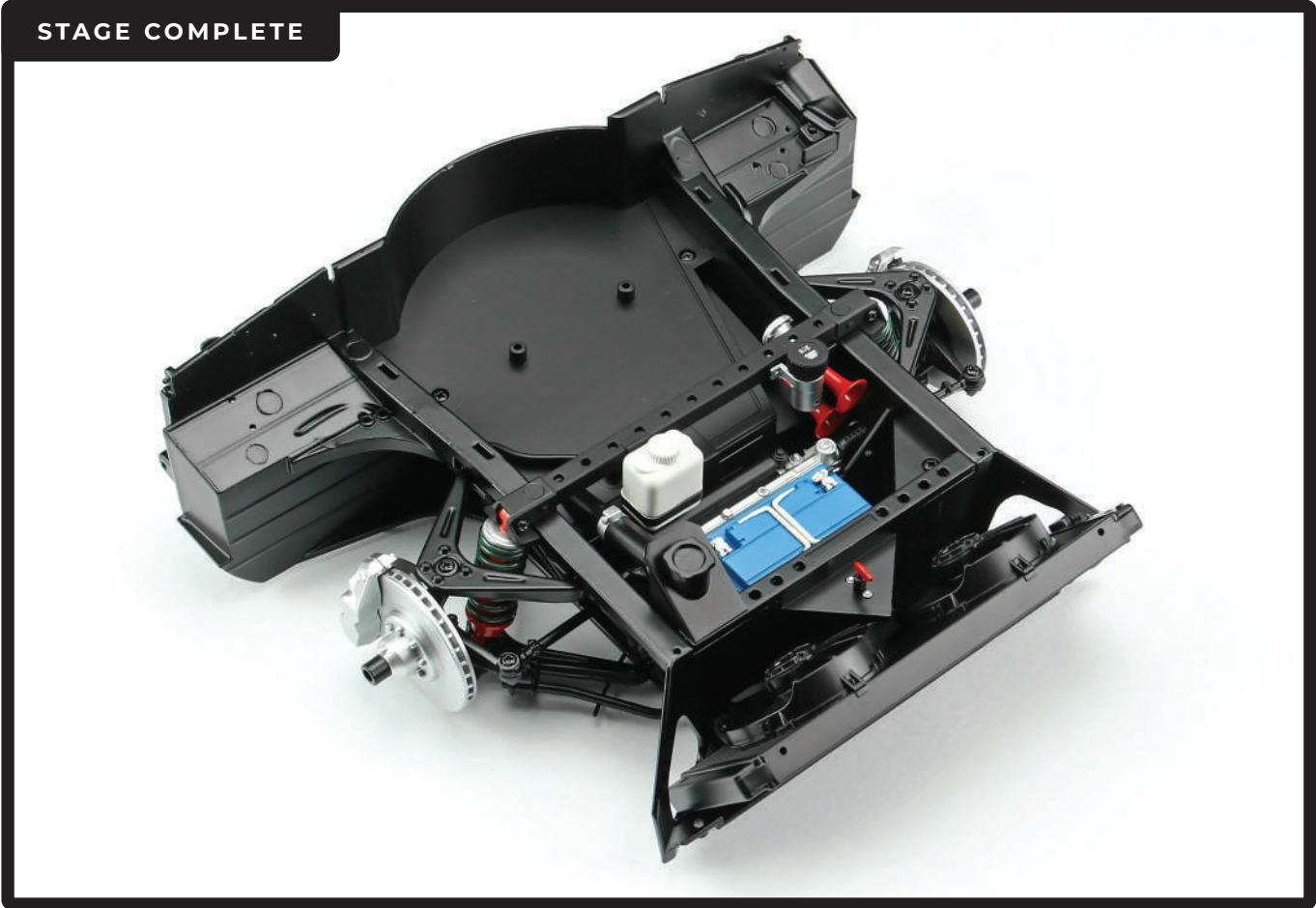

Stage 71: Fitting the Radiator Pipes and Tie Rods

In this stage you'll connect the radiator pipes and secure the panel by fitting tie rods.



STAGE 71 PARTS LIST

Name
Left radiator pipe
Radiator tie rod x2
Right radiator pipe



Stage 71: Fitting the Radiator Pipes and Tie Rods



First take the right radiator pipe. Note that it has two fixing plates (arrows) as well as a pin at one end (circled).

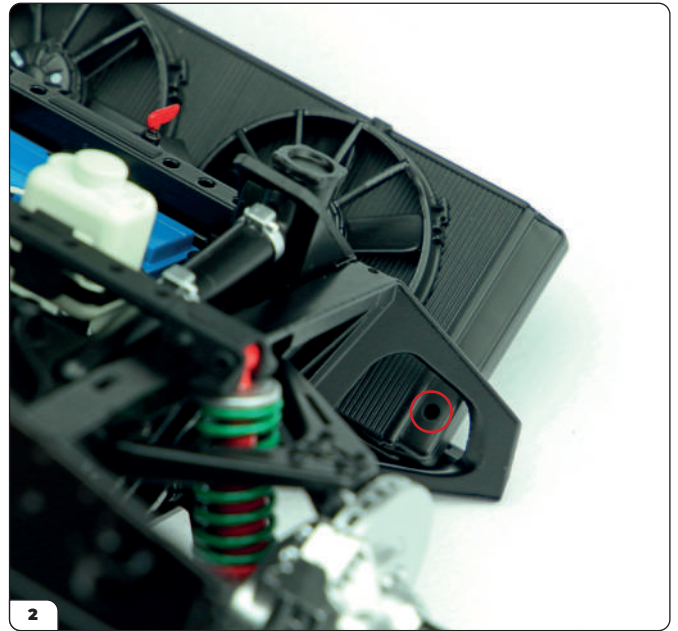

Take the front frame assembly and locate the hole on the lower right corner of the radiator (circled) for inserting the right radiator pipe pin.

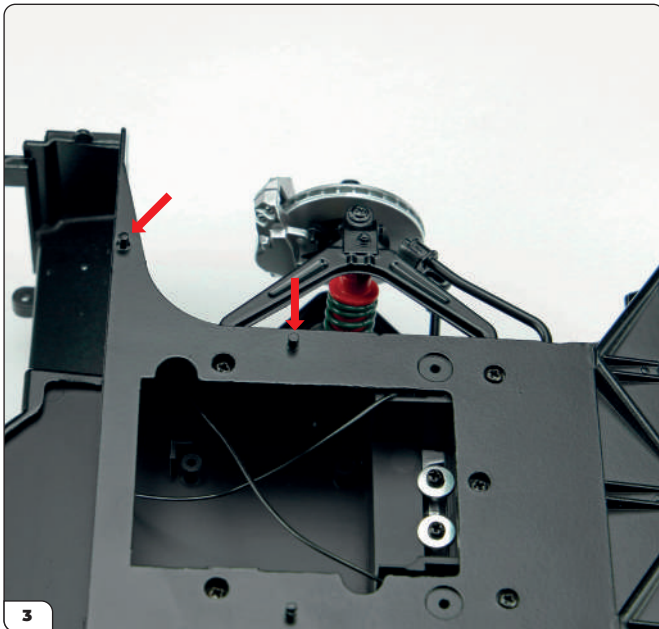

Turn the assembly over and locate the two pins (arrows) for fitting the right radiator pipe fixing plates.



Push the pin of the pipe through the opening in the frame and into the hole highlighted in step 2 as shown. You may need to rotate the tube slightly to fit the pin fully.

Stage 71: Fitting the Radiator Pipes and Tie Rods

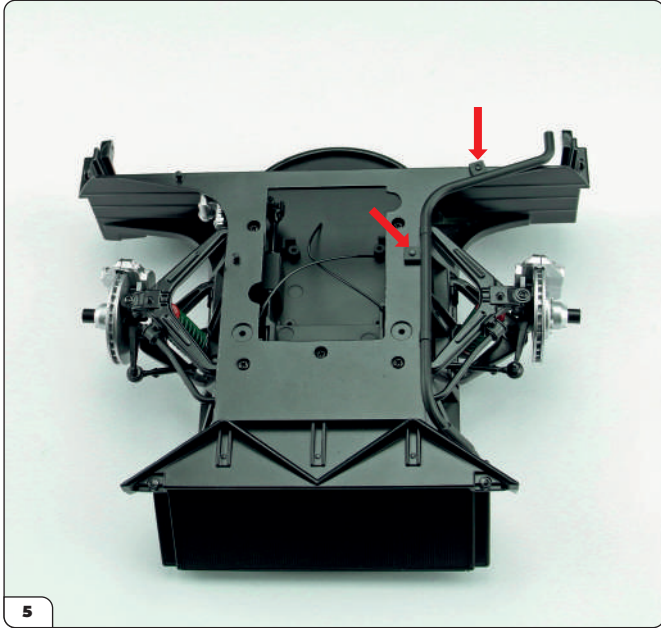

Once the pin is in place, turn the assembly over and fit the fixing plates of the pipe over the pins highlighted in step 3 (arrows). Take care not to trap the battery cables when fitting the plates – we recommend tucking them inside the frame as shown in the image.



Next take the left radiator pipe, which has two fixing plates (arrows) and a pin at one end (circled).

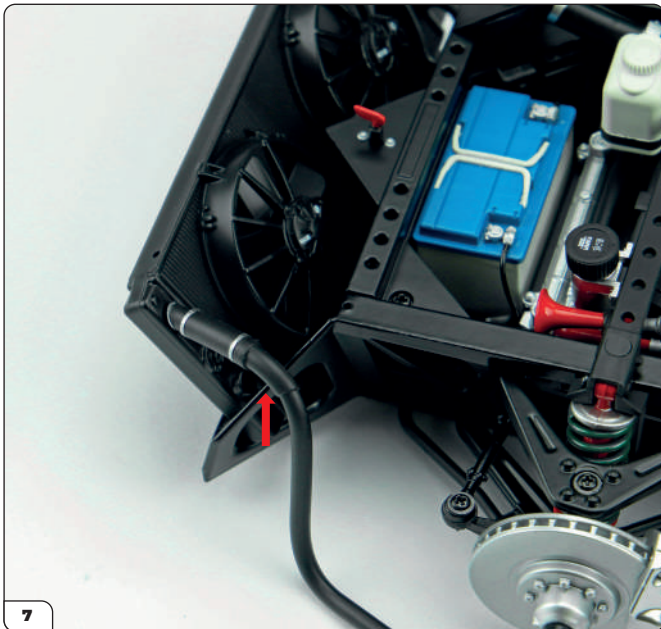

Press the pin into the corresponding hole in the corner of the radiator. Note that this pipe runs over the frame rather than through it (arrow).

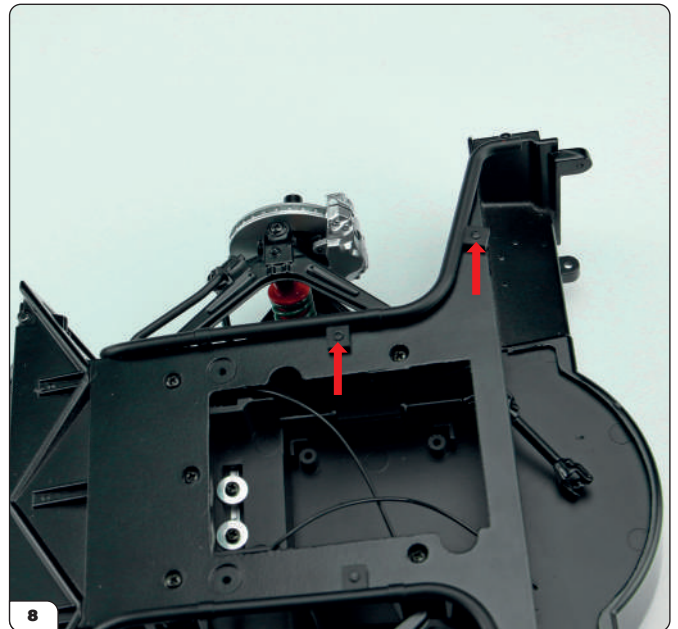

With the pin in place, turn the assembly over and press the fixing plates of the pipe over the pins on the underside of the frame (arrows).

Stage 71: Fitting the Radiator Pipes and Tie Rods

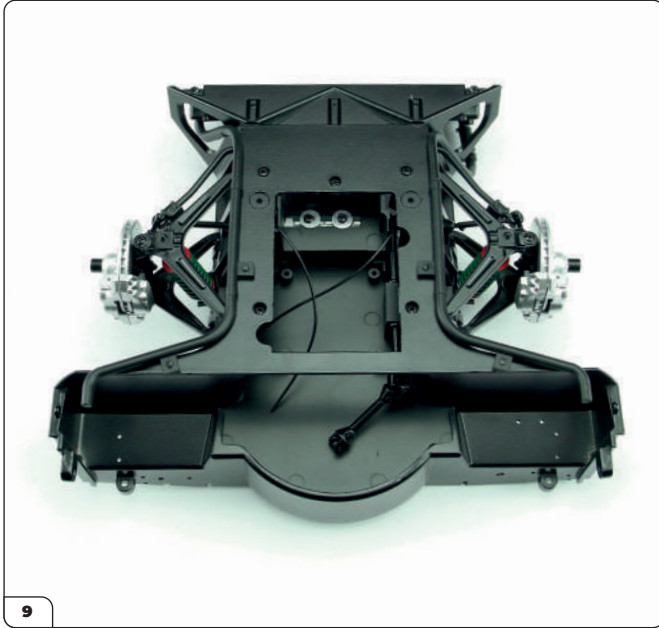

The two radiator pipes should look like this once installed.

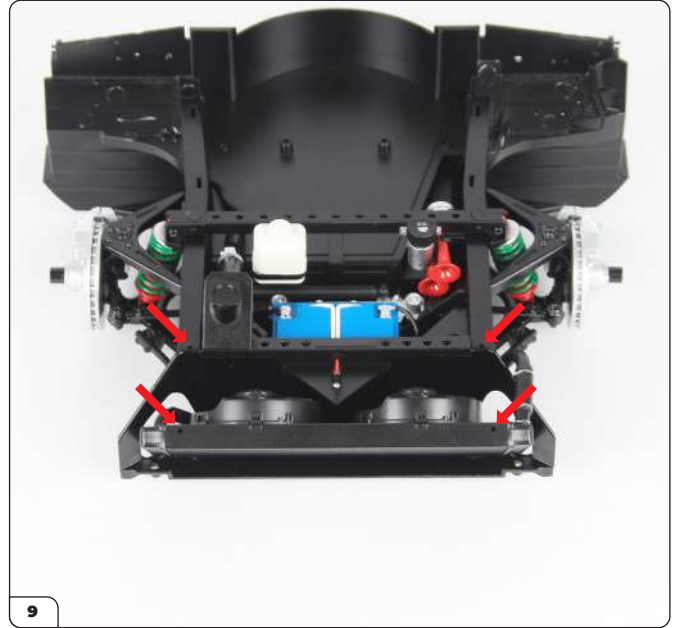

Turn the assembly back over and locate the four holes for fitting the radiator tie rods (arrows).

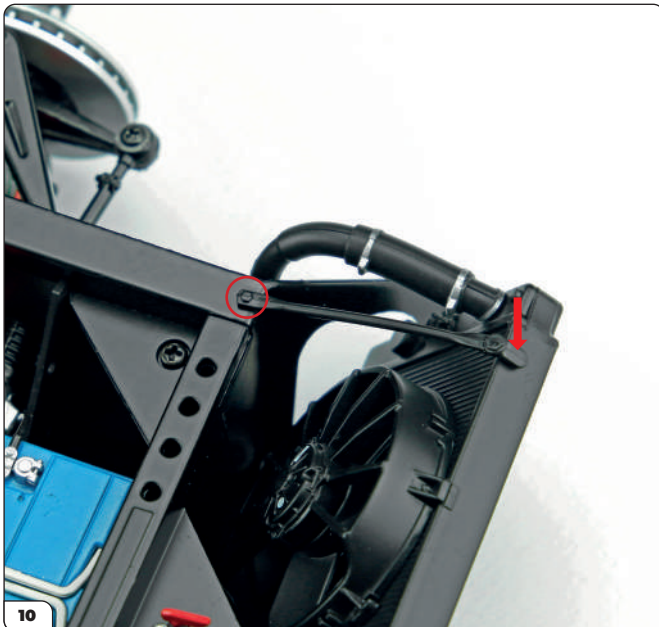

Take one of the tie rods and press the pin at the angled end into the hole in the radiator (arrow). Fit the pin at the other end into the hole in the frame (circled).

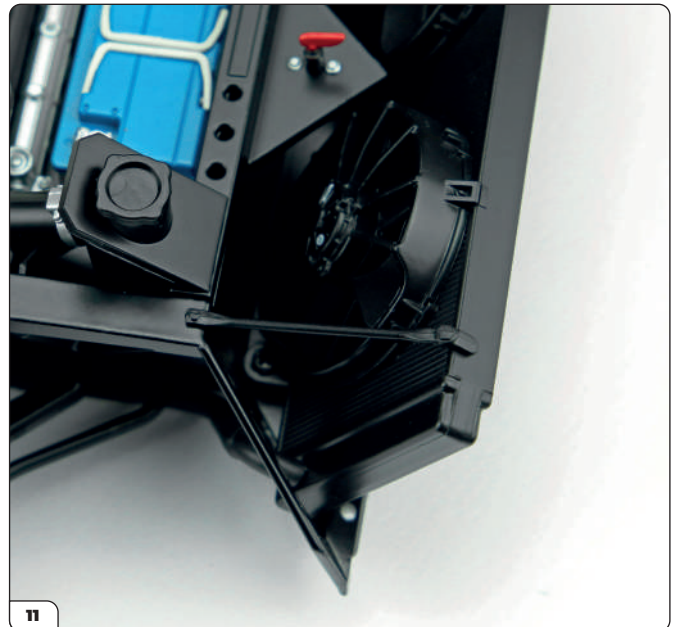

Fit the remaining tie rod on the other side in the same manner.

Stage 71: Fitting the Radiator Pipes and Tie Rods

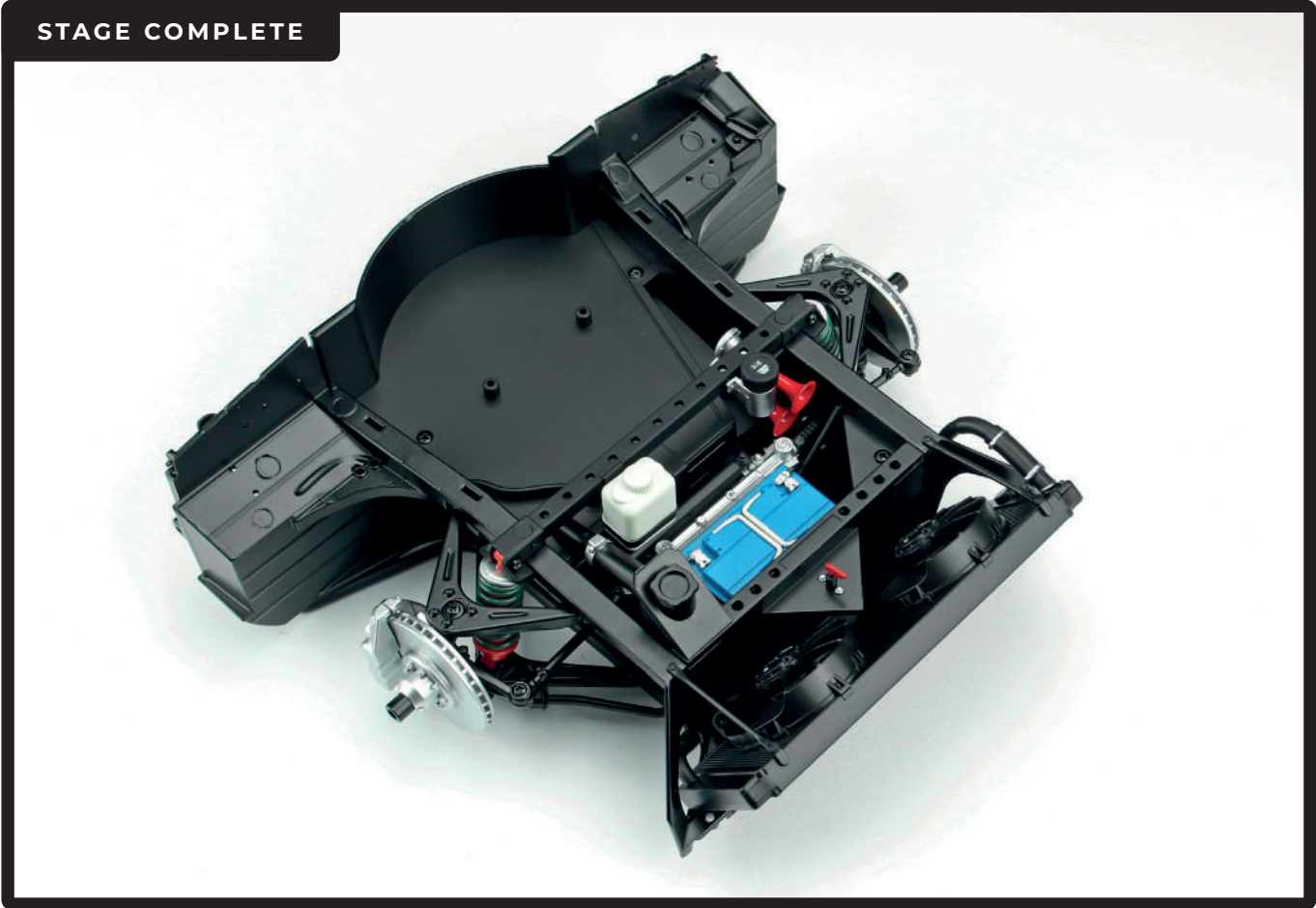

Stage 72: Adding Essential Parts to the Frame (1)

In this stage you'll install the reservoirs for the clutch and brake fluid to the frame, along with the left relay box, the indicator intermittence system, and the wiper motor.



STAGE 72 PARTS LIST

Name
Reservoir plate
Clutch/brake liquid reservoir
Relay box
Wiper motor
Clutch/brake liquid reservoir
Indicator intermittence system

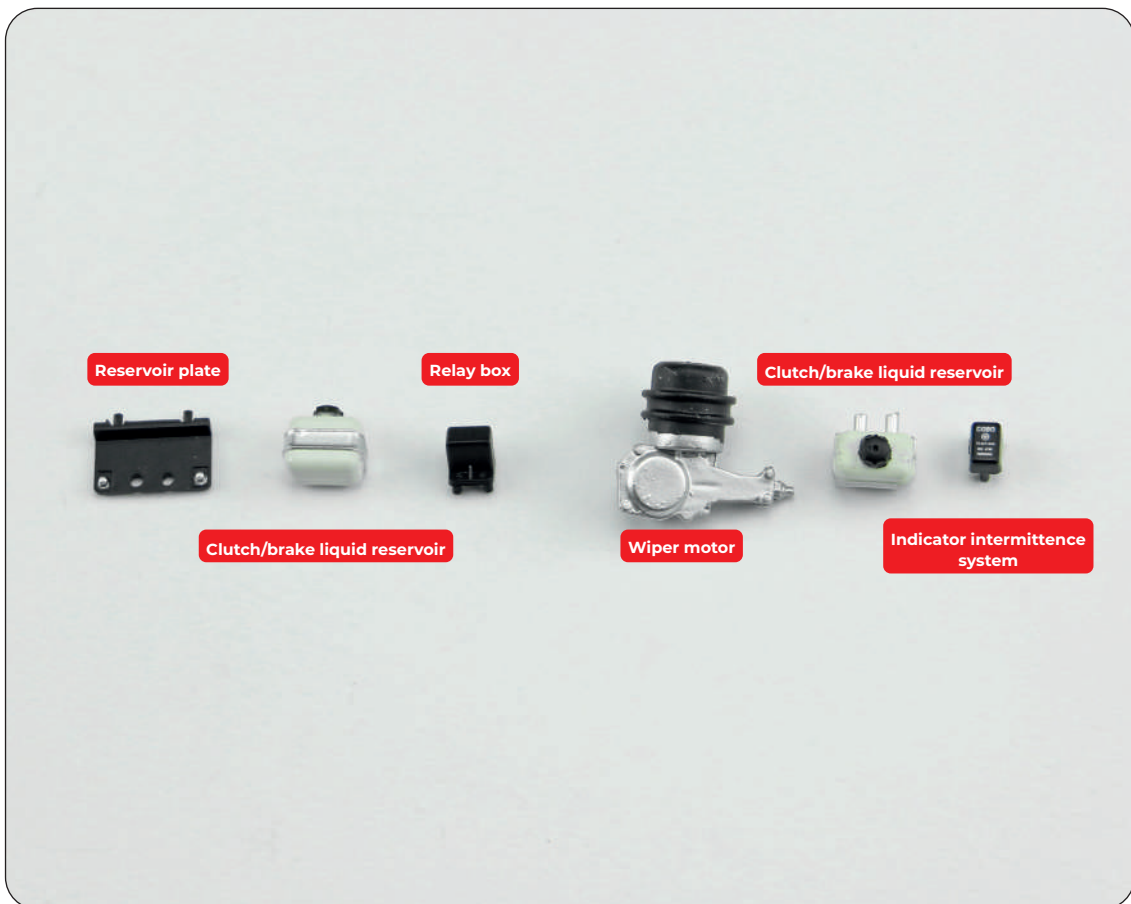

Stage 72: Adding Essential Parts to the Frame (1)

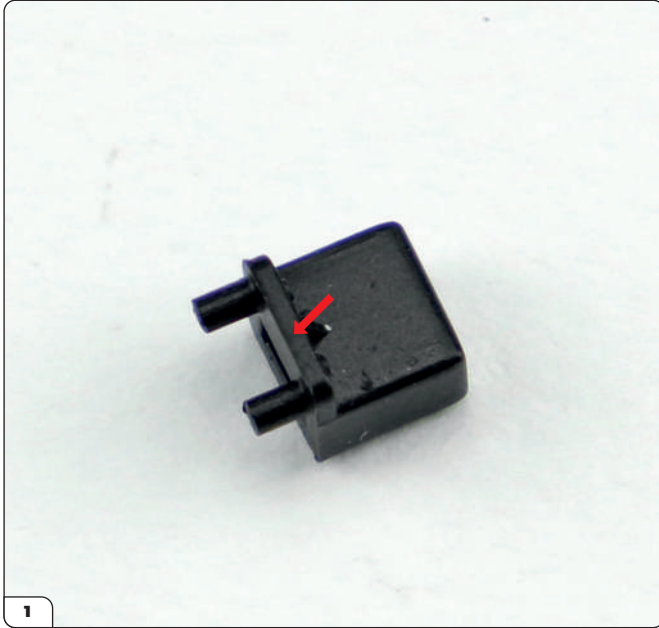

First identify the relay box, which has two pins on a raised plate (arrow).

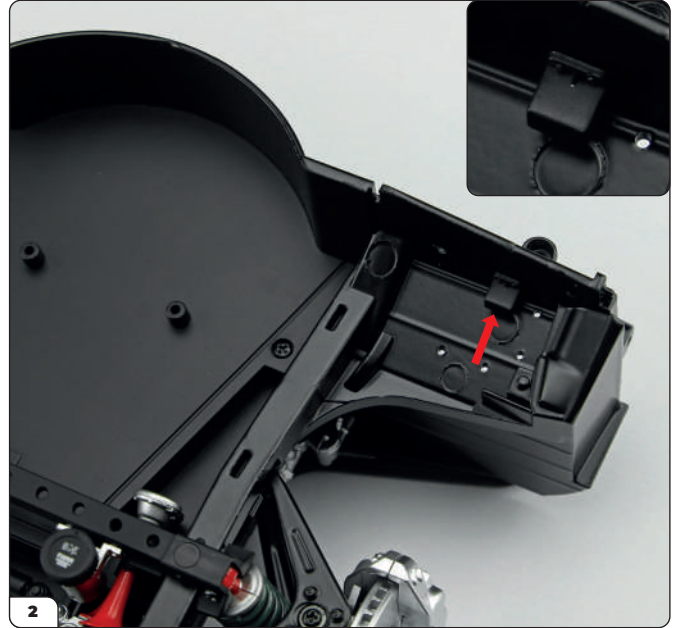

Place the frame assembly on your work surface and fit the relay box into two holes on the back left side of the frame (arrow). The raised plate should be oriented upwards (inset).

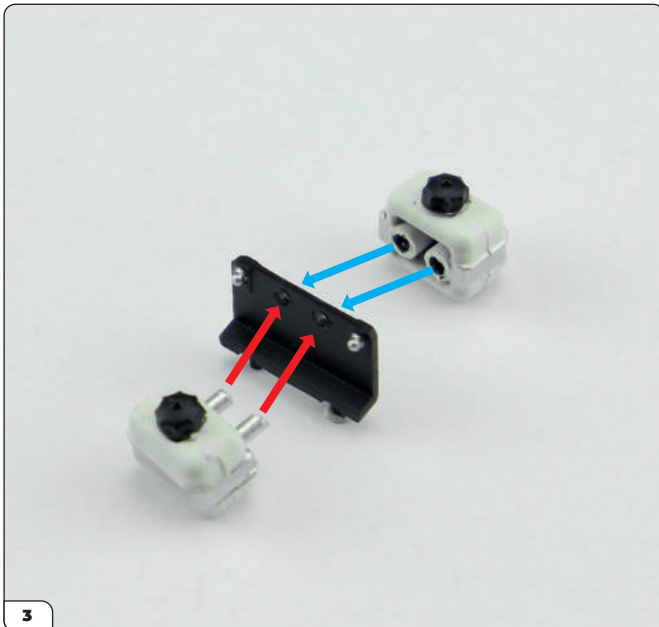

Take the two clutch/brake reservoirs and the reservoir plate and align them with each other as shown. Fit the reservoir with two silver pins through the two holes in the plate (red arrows). Once the reservoir is flush with the plate, push the two holes of the other reservoir into the silver pins protruding through the plate (blue arrows).



The reservoirs and plate should look like this once fitted together.

Stage 72: Adding Essential Parts to the Frame (1)



Press the two pins on the reservoir plate into the two corresponding holes located in front of the relay box. Note the orientation of the lip on the plate (arrow).

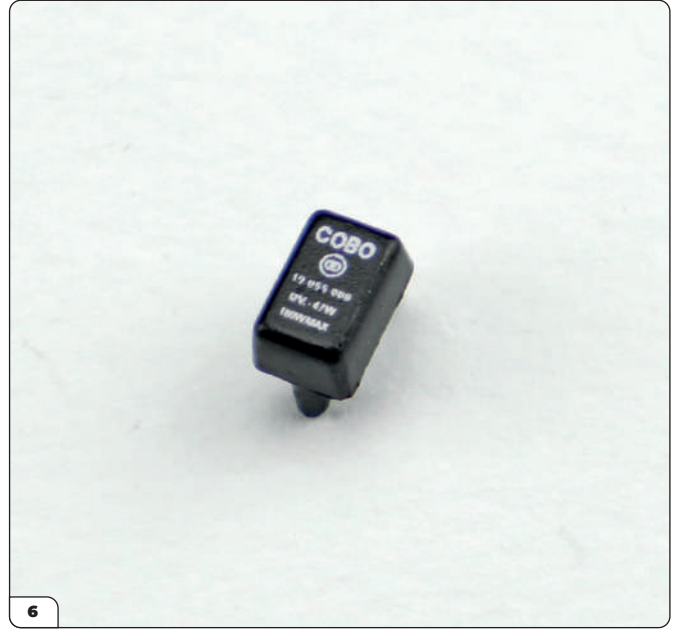

Take the indicator intermittence system and note the writing on the face of the part. It also has two pins on the back for fitting it in place.



Press the pins of the indicator system into the two holes on the left of the frame, next to the reservoirs and relay box, with the writing oriented the correct way up.



Take the wiper motor and lay it on your work surface as shown. Its pin is shaped so that fitting it in the correct orientation is easier (arrow).

Stage 72: Adding Essential Parts to the Frame (1)



Press the wiper motor into the hole on the left side of the frame, next to the reservoirs, as shown.

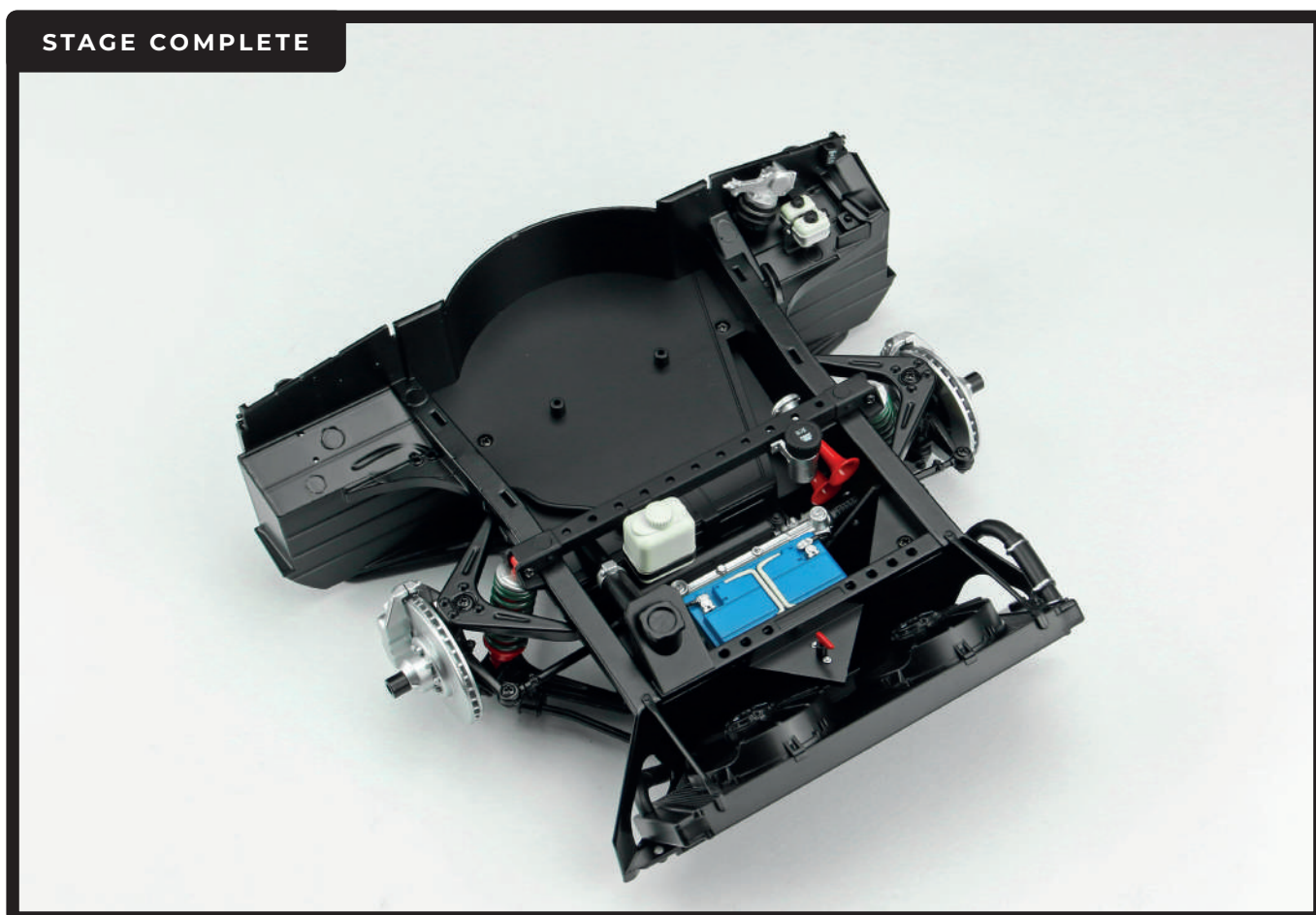

Stage 73: Adding Essential Parts to the Frame (2)

Next you'll add the right relay box and the voltage regulator to the frame along with the bonnet hooks and support buffers.



STAGE 73 PARTS LIST

Name
Bonnet support buffer
Relay box
Right bonnet hook
Left bonnet hook
Voltage regulator
Bonnet support buffer



Stage 73: Adding Essential Parts to the Frame (2)

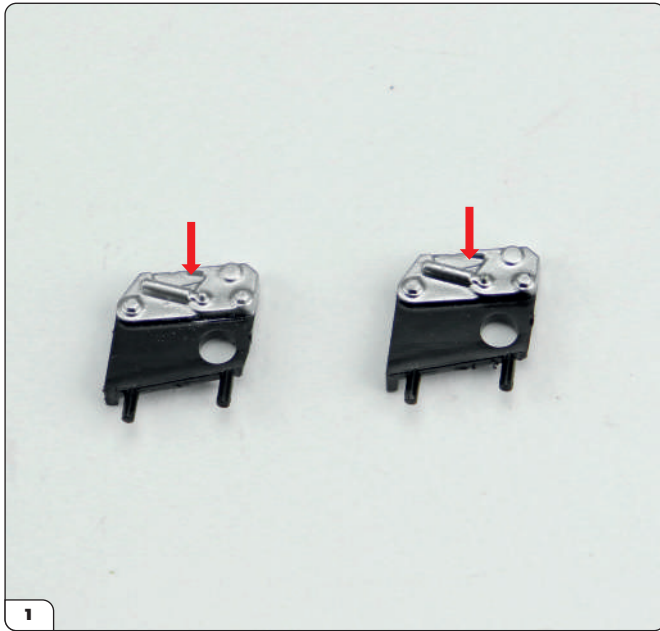

The two bonnet hooks are supplied in bags marked 'R' (right) and 'L' (left) to help differentiate them from each other. Note that the detailed face of the parts (arrows) will be oriented towards the left-hand side of the frame when fitted.



Take the right bonnet hook and insert it in the two holes located on the right-hand side of the frame as shown.



Fit the left bonnet hook into the two holes next to the reservoirs in the same manner.



Take the two bonnet support buffers. These are identical and can be mounted on either the right- or left-hand side of the frame.

Stage 73: Adding Essential Parts to the Frame (2)

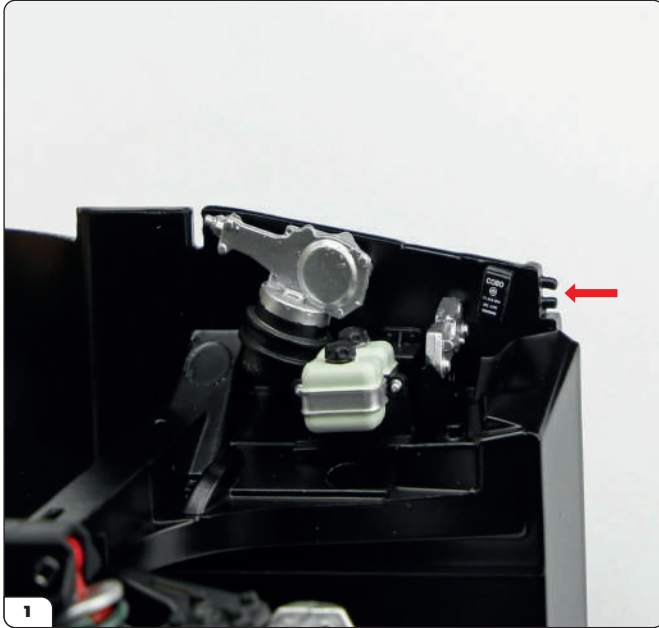

On the left-hand side of the frame, there are two pins (arrow) for mounting the support buffer.

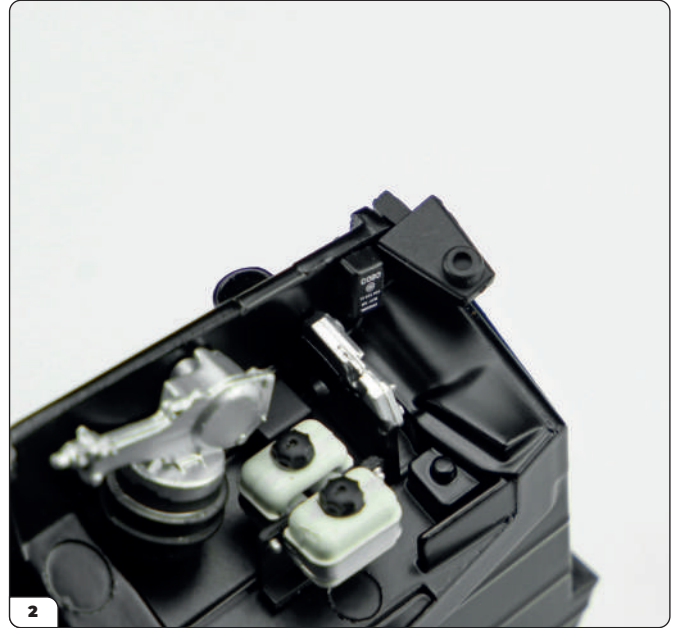

Press one of the support buffers onto the pins so that the circular hole (arrow) is facing upwards as shown. If getting the fit flush is difficult, you can try pressing the assembly against a flat surface to push the support buffer into place – be careful not to apply pressure to the radiator panel as this may damage it.

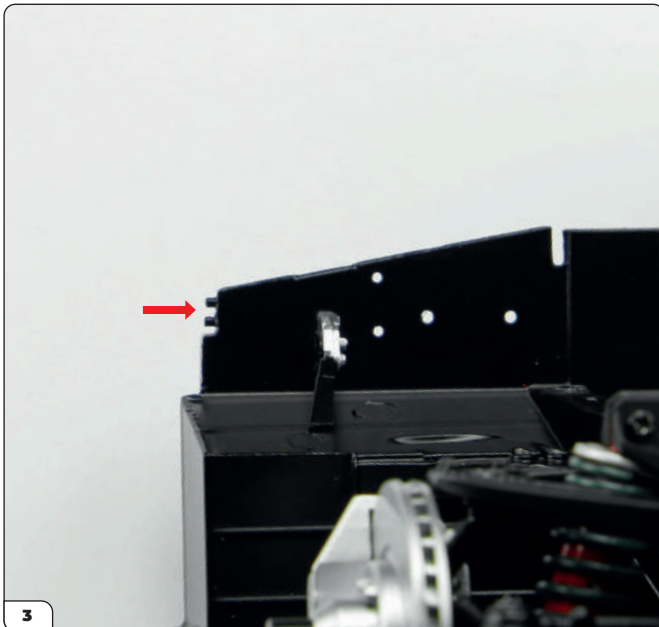

On the other side of the frame, there are two more pins for fitting the other support buffer (arrow).



Press the support buffer in place in the same manner as before.

Stage 73: Adding Essential Parts to the Frame (2)



Next press the voltage regulator into the two vertical holes next to the bonnet hook on the right-hand side of the frame. Note that the rounded edges should be facing upwards (arrows).



Take the relay box and press it into the two horizontal holes next to the voltage regulator as shown. Make sure the triangular ridges (arrows) are oriented upwards.

STAGE COMPLETE

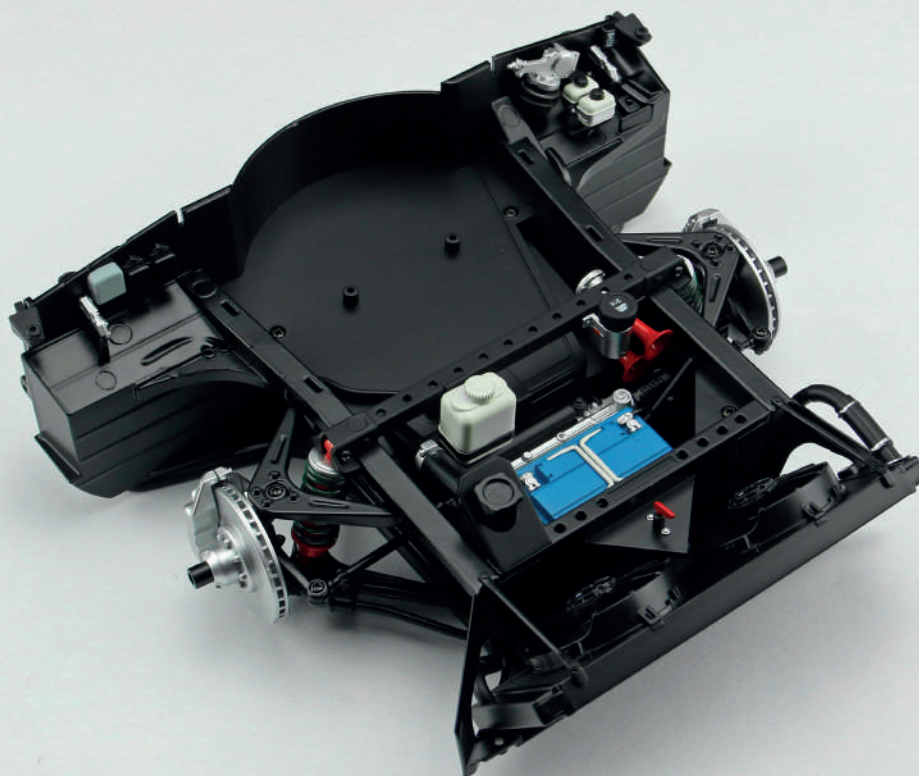

Stage 74: Assembling and Fitting the Spare Wheel

In the final stage for this pack, the spare wheel is assembled and fitted into its housing.



STAGE 74 PARTS LIST

Name
Wheel rim
Pirelli tyre
Spare wheel support
Type B screws x3



Stage 74: Assembling and Fitting the Spare Wheel



The spare tyre is slightly different to the other tyres supplied with the model – this is softer and should not require heating in order to fit it onto the rim.



Similarly, the inner part of the rim is finished differently from the others supplied.



Lay the tyre flat on your work surface and press the rim into it by stretching the tyre.



Adjust the lip of the tyre until it fits flush with the rim. The tyre can be squeezed easily until it fits correctly.

Stage 74: Assembling and Fitting the Spare Wheel



Check the other side of the tyre and adjust so that the fit is flush on both sides.

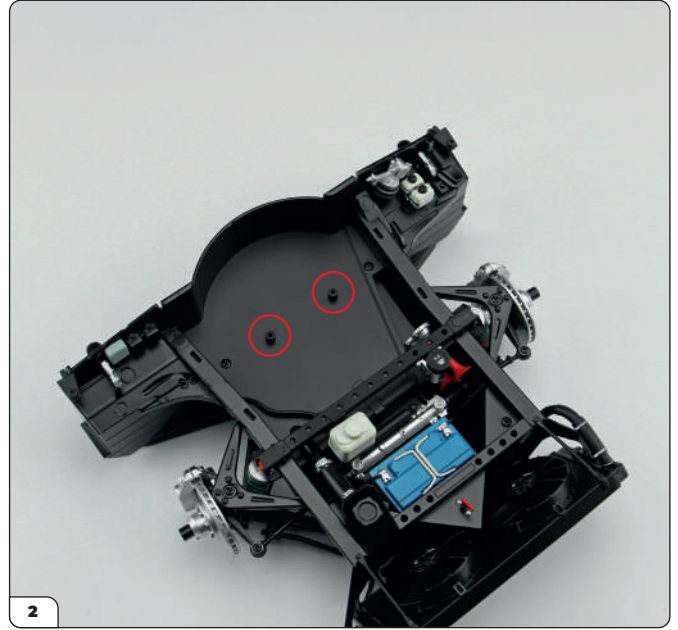

Now take the frame assembly and place it on your work surface. There are two raised columns inside the spare wheel housing (circled) for mounting the spare wheel support.

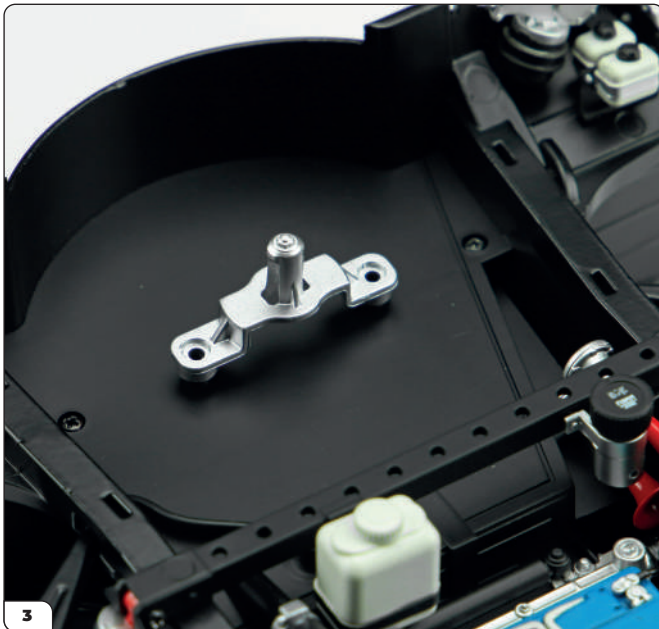

Take the spare wheel support and position it on the columns highlighted in the previous step.

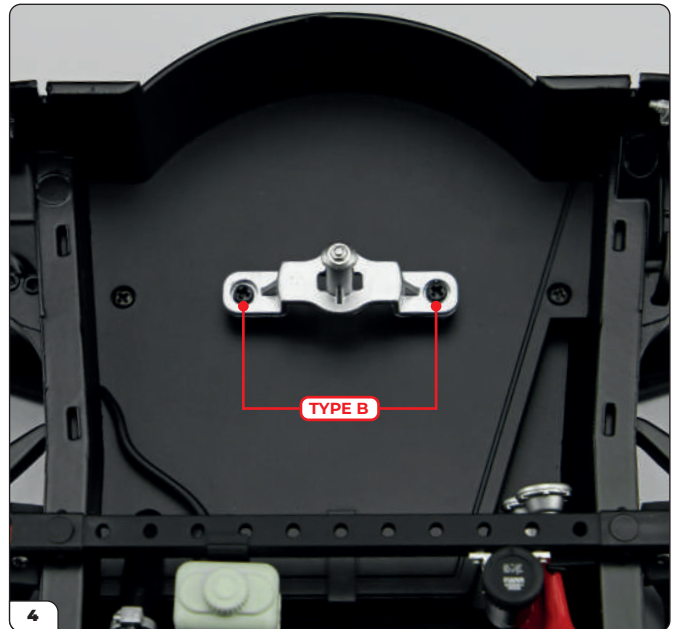

Secure the support in place using 2x Type B screws.

Stage 74: Assembling and Fitting the Spare Wheel

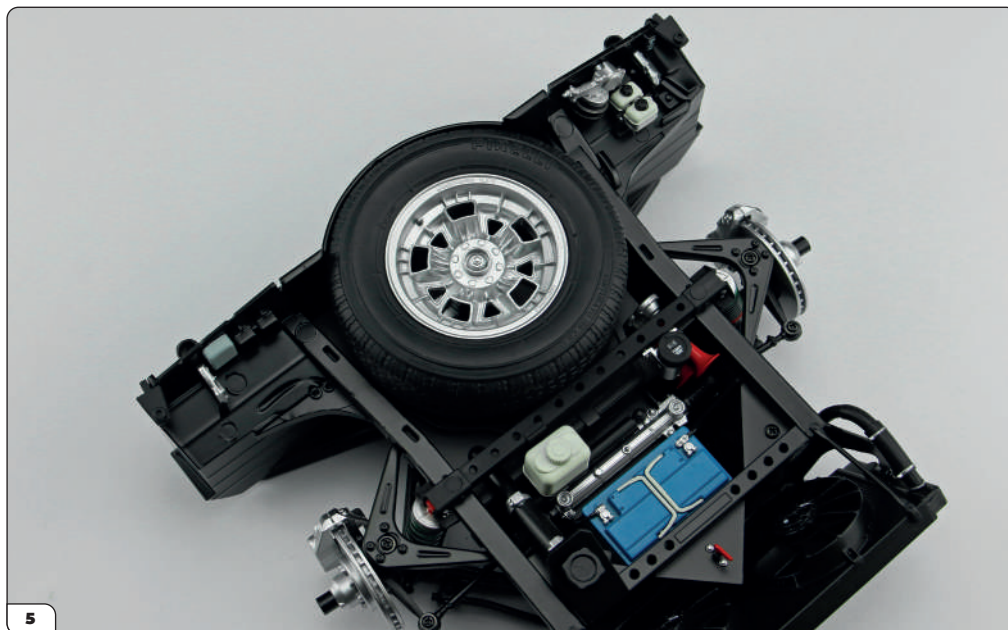

To fit the wheel onto the support, press it onto the pin of the support until it snaps into place. Be careful not to put pressure on the housing, which is made of plastic and could break. Instead, apply pressure on the frame, which is made of metal and is much more resistant.

STAGE COMPLETE

