



FERRARI

312 T4

THE LEGENDARY 1970s F1 FERRARI

PACK

09

STAGES 73-82



SCALE
1:8

AGORA
MODELS®



FERRARI

312 T4

SCALE
1:8

Contents

STAGE 73 SUSPENSION SUPPORT AND REINFORCEMENTS.....	1
STAGE 74 LEFT REAR SHOCK ABSORBER.....	5
STAGE 75 RIGHT REAR SHOCK ABSORBER.....	9
STAGE 76 LEFT REAR STUB AXLE AND SEMI-AXLE..	13
STAGE 77 RIGHT REAR STUB AXLE AND SEMI-AXLE	17
STAGE 78 LEFT REAR TYRE.....	21
STAGE 79 COMPONENTS FOR THE LEFT REAR RIM.....	25
STAGE 80 RIGHT REAR TYRE	29
STAGE 81 COMPONENTS FOR THE RIGHT REAR RIM.....	31
STAGE 82 EXHAUST PIPES SUPPORT END PLATES	35

© Agora Models

AGORA
MODELS.

WARNING: NOT SUITABLE
FOR CHILDREN UNDER THE
AGE OF 14. THIS PRODUCT IS
NOT A TOY AND IS NOT
DESIGNED OR INTENDED
FOR USE IN PLAY.
ITEMS MAY VARY FROM
THOSE SHOWN.

Produced under license of Ferrari S.p.A.
The name FERRARI, the PRANCING HORSE
device, all associated logos and distinctive
designs are property of FERRARI S.p.A.
The body designs of the Ferrari cars are
protected as Ferrari S.p.A. property under
design, trademark and trade dress regulations.

SUSPENSION SUPPORT AND REINFORCEMENTS

IN THIS STAGE YOU'LL CONTINUE TO BUILD THE REAR SUSPENSION OF YOUR 1:8 SCALE FERRARI 312 T4. YOU'LL NEED THE WISHBONES PROVIDED WITH STAGES 70 AND 72, ALONG WITH THE PARTS SUPPLIED HERE.

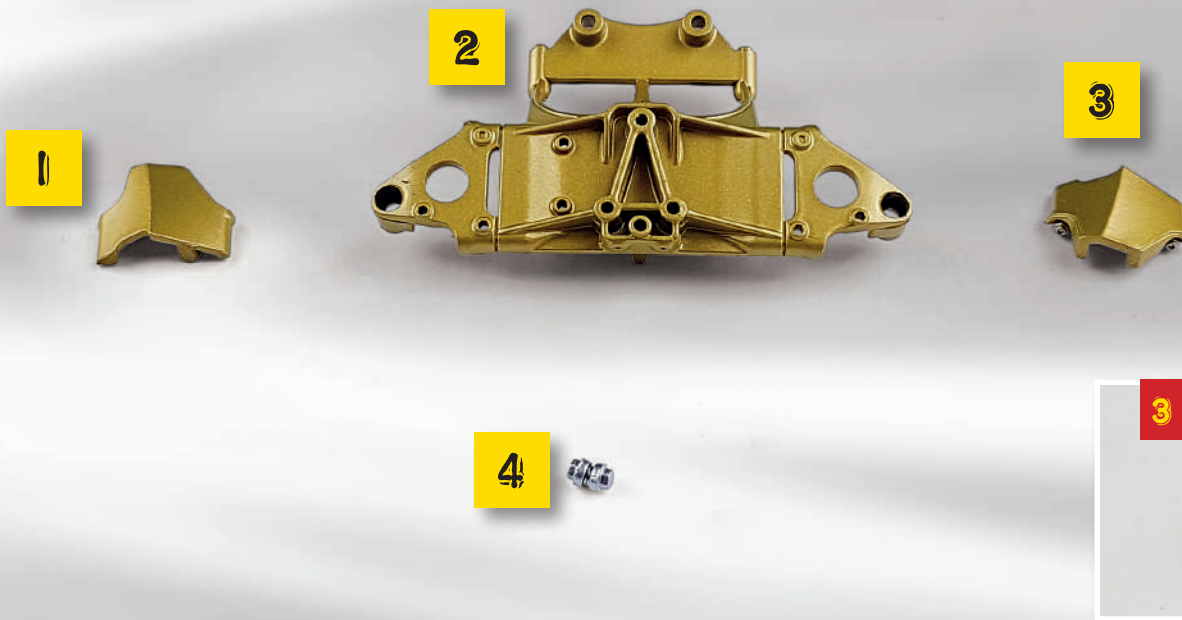

LIST OF PARTS

- 1 Left inner reinforcement
- 2 Suspension support
- 3 Right inner reinforcement
- 4 Two false magnetic bolts

SCREWS

Three type D screws



01

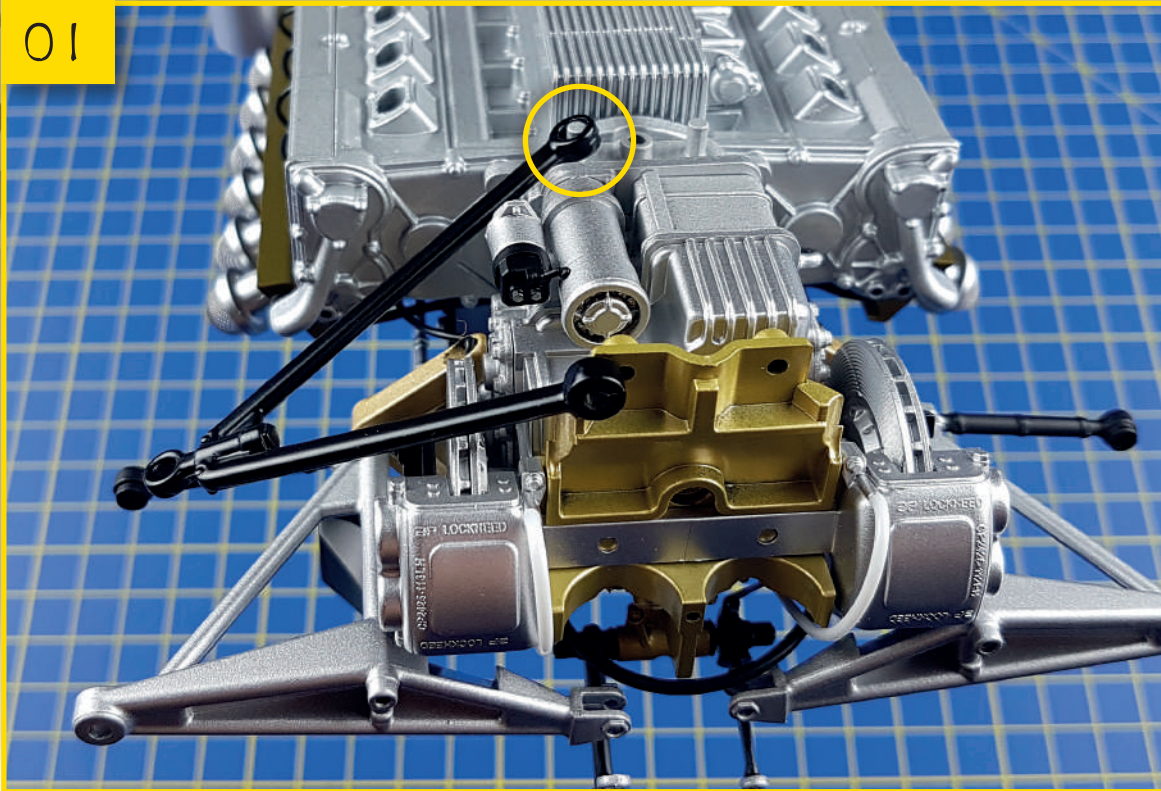

73-01 Place the model upside down on your work surface. Then place the right lower wishbone (marked R) from stage 72 on the model as shown in the image.

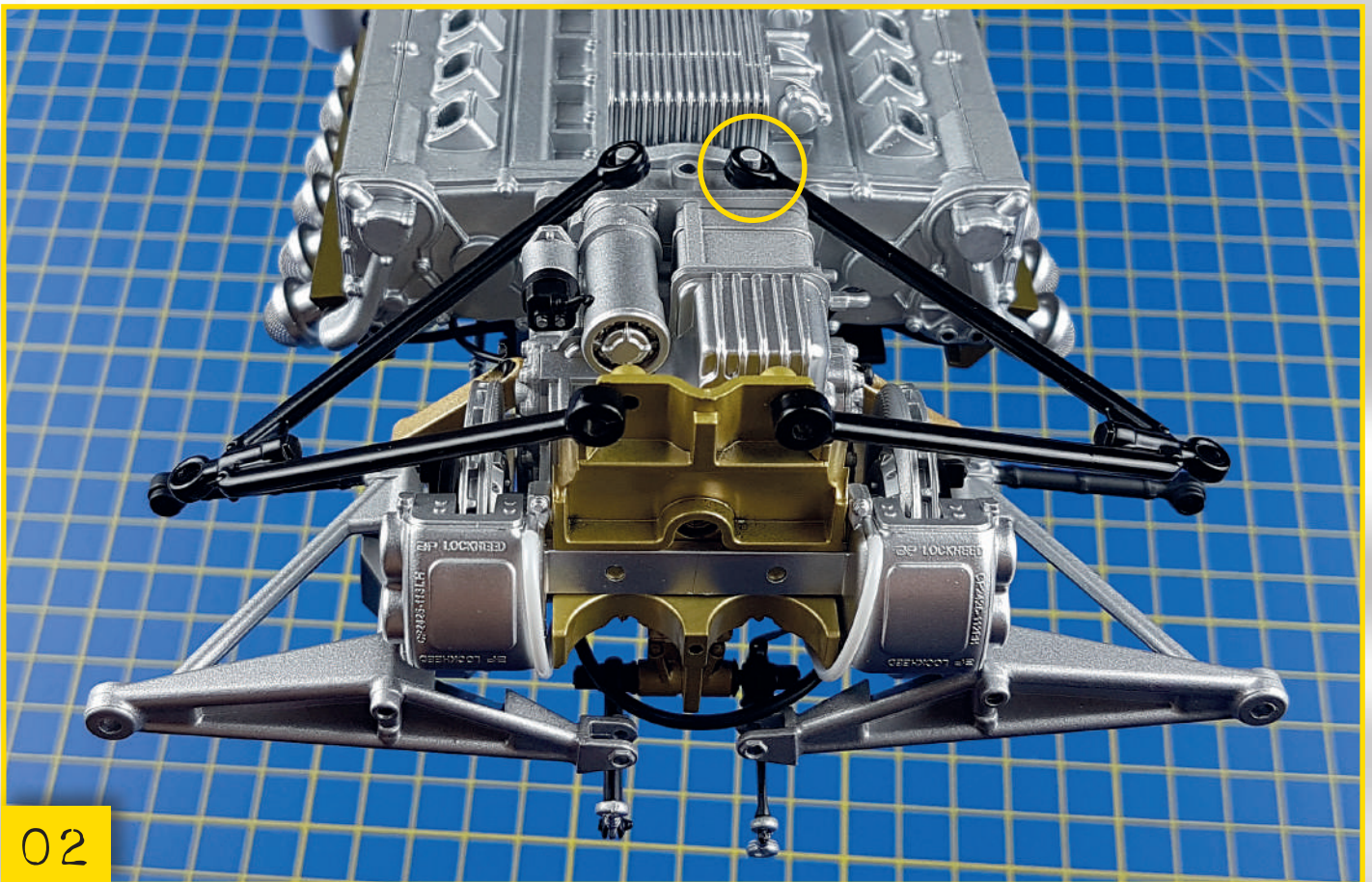

02

73-02 Position the left wishbone (marked L), included with stage 70, on the other side of the model.

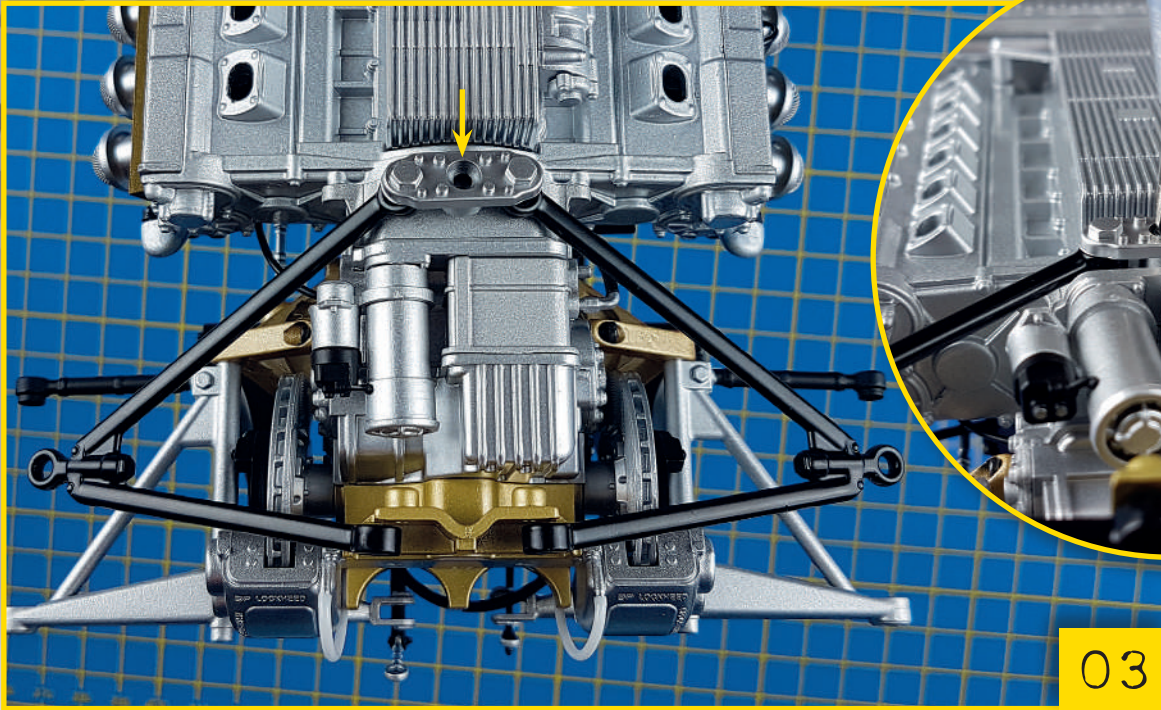

73-03 Place the support (supplied with stage 72) over the front of the wishbone (yellow arrow) and secure it with a type B screw (inset).

73-04 This is how the rear suspension section looks from below. The two wishbones have been mounted on the model and secured with the support.

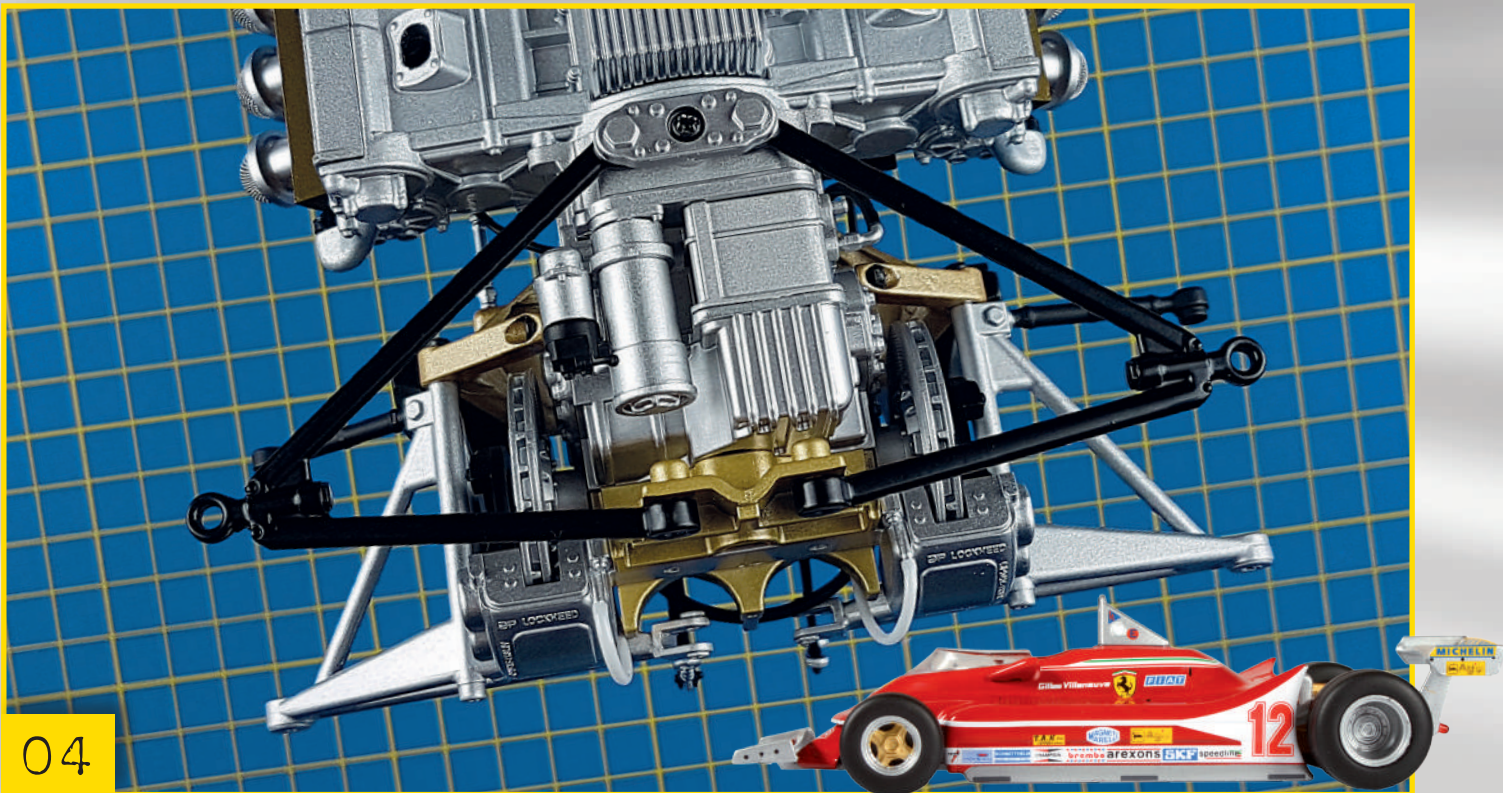

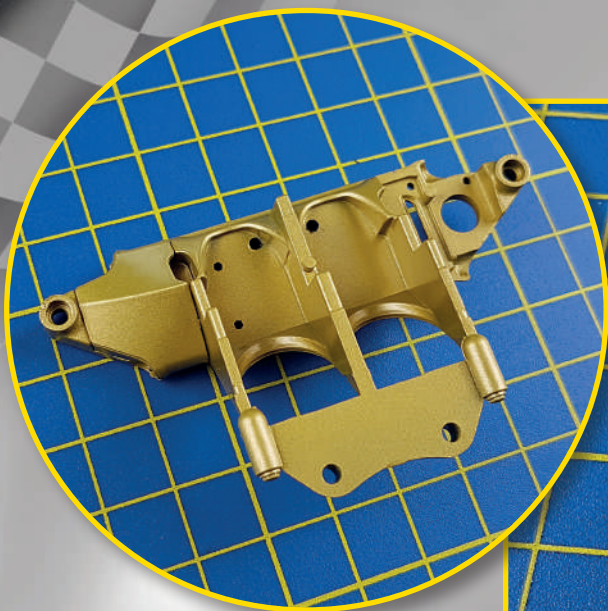

73-05 Firmly press the two reinforcements onto the suspension support. Make sure the parts are aligned.

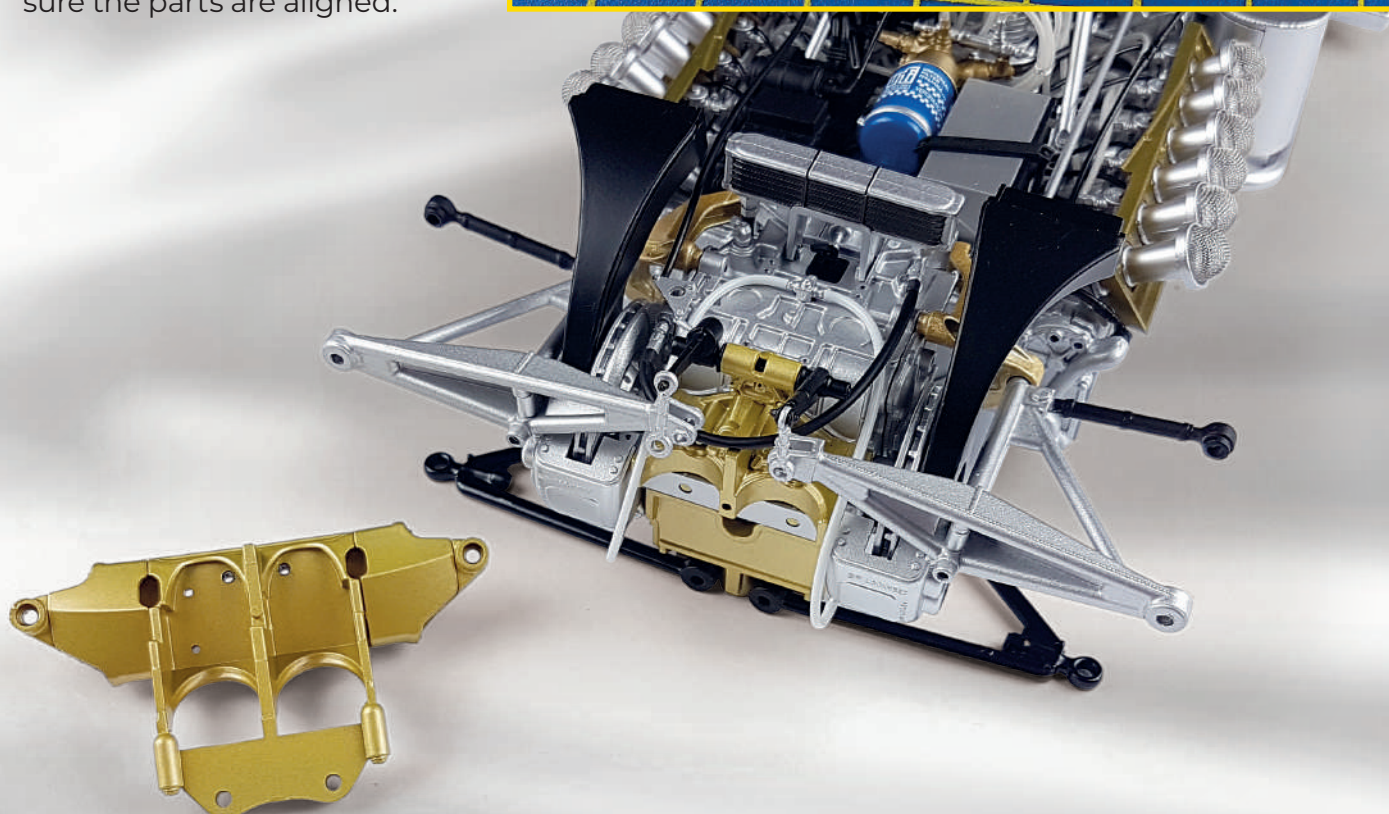
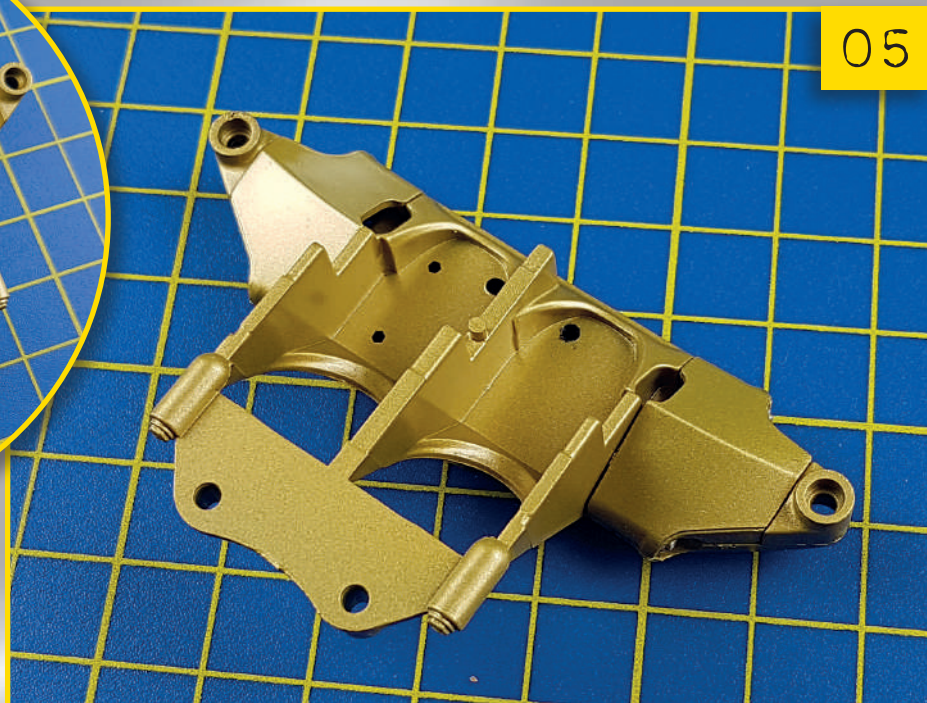

FINAL RESULT

This is what you completed in this step of the assembly. Put it carefully to one side.

In the next stage

The left rear shock absorber.



LEFT REAR SHOCK ABSORBER

THIS STAGE INCLUDES THE FIRST REAR SHOCK ABSORBER, WHICH CAN BE PUT TO ONE SIDE FOR NOW. FIRST, YOU'LL BE SECURING THE SUSPENSION SUPPORT ONTO THE MODEL.

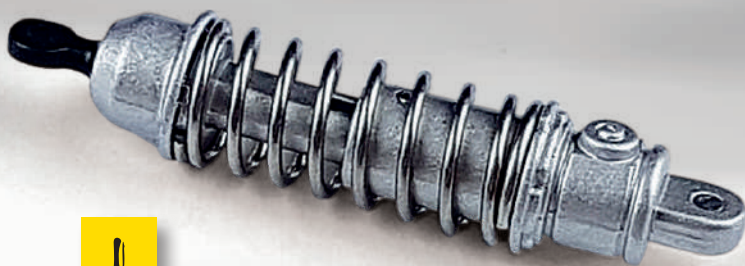

2 type E screws



2 type K screws



LIST OF PARTS

1 Left rear shock absorber

SCREWS

Two type E screws

Two type K screws



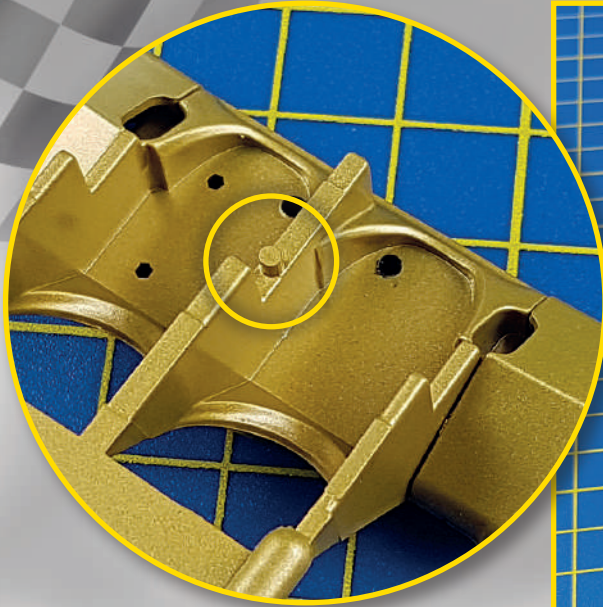

74-01

Take the model and the suspension support that you assembled during the last steps. The support has a central pin (circled) that must be inserted into the hole in the model (arrow).

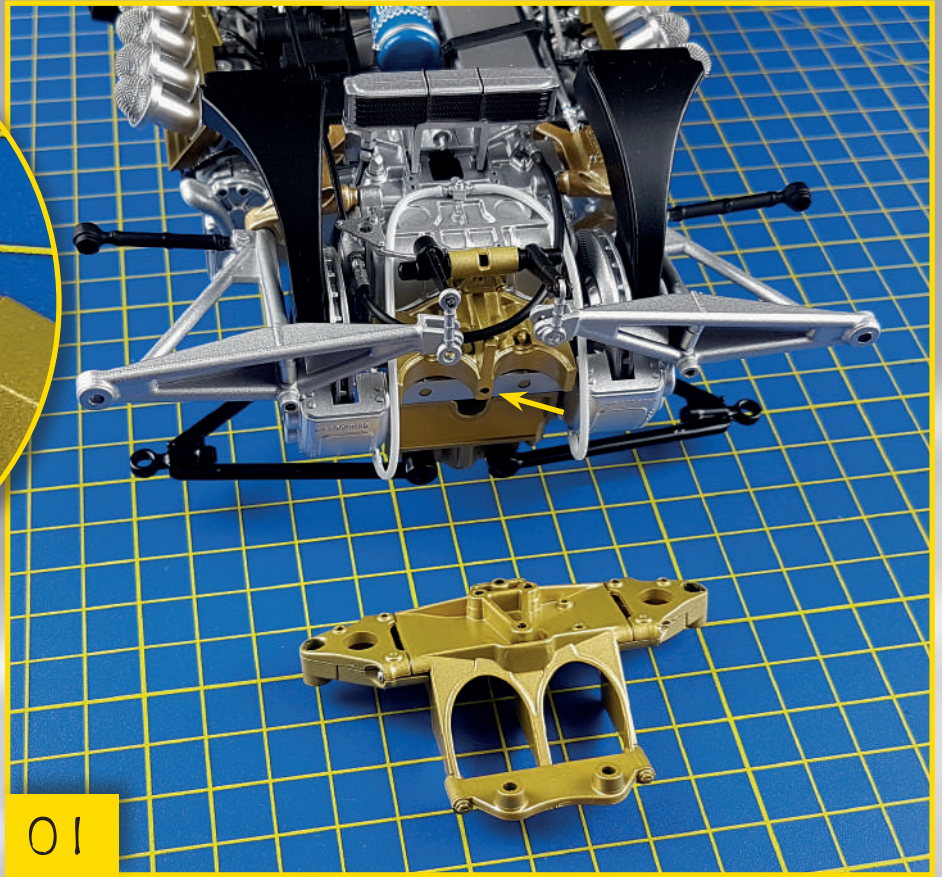

01

02

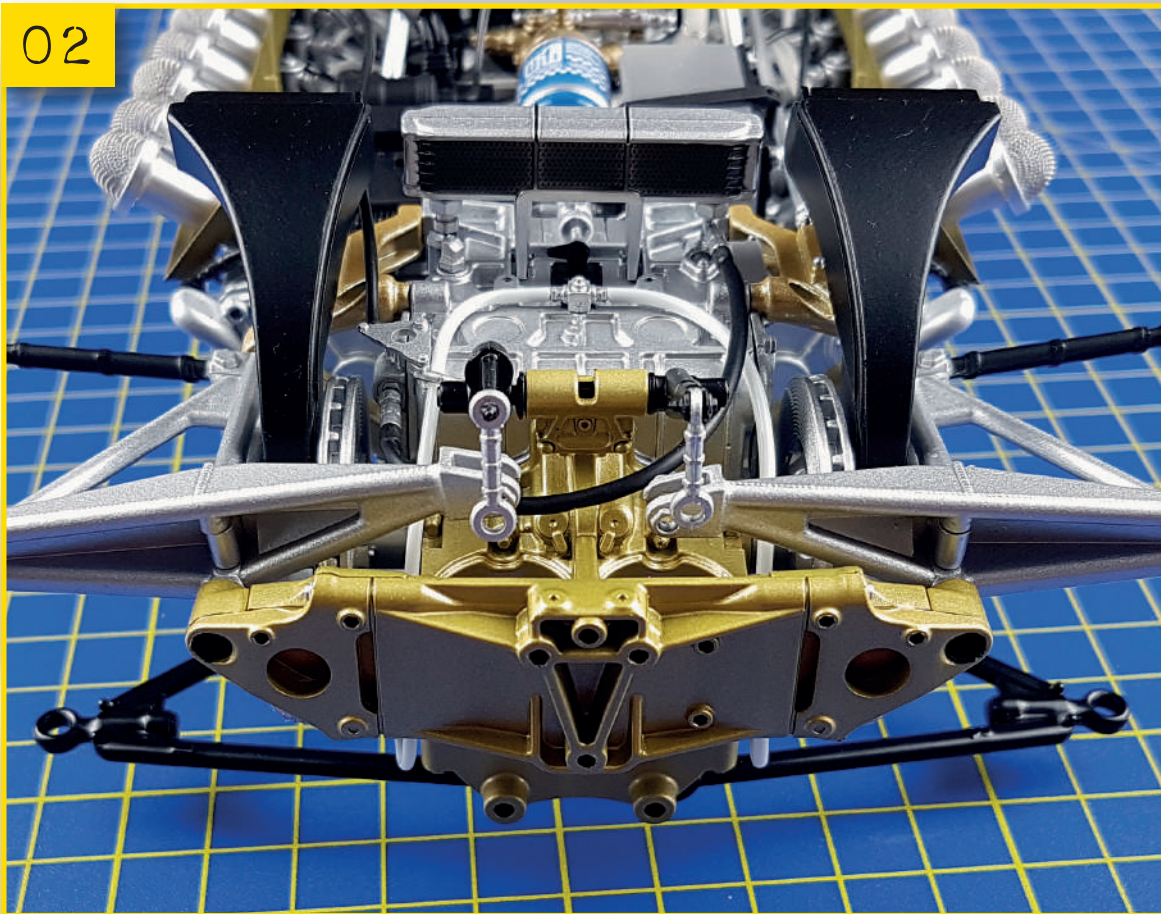

74-02

Join the suspension support to the model.

03

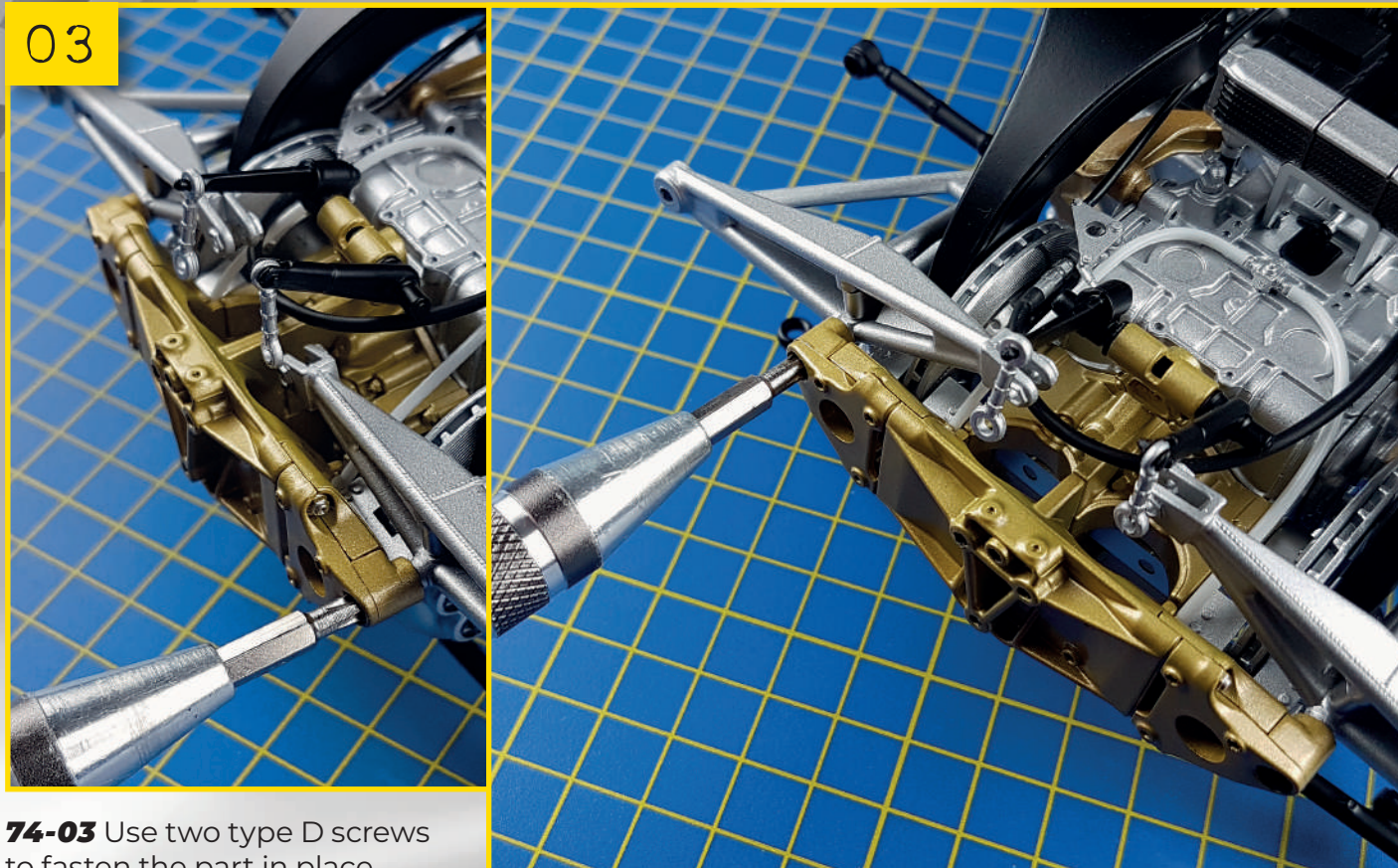

74-03 Use two type D screws to fasten the part in place.

74-04 The heads of these screws will be covered by the two magnetic bolts from stage 73 (inset). Place them over the screw heads as shown.

04

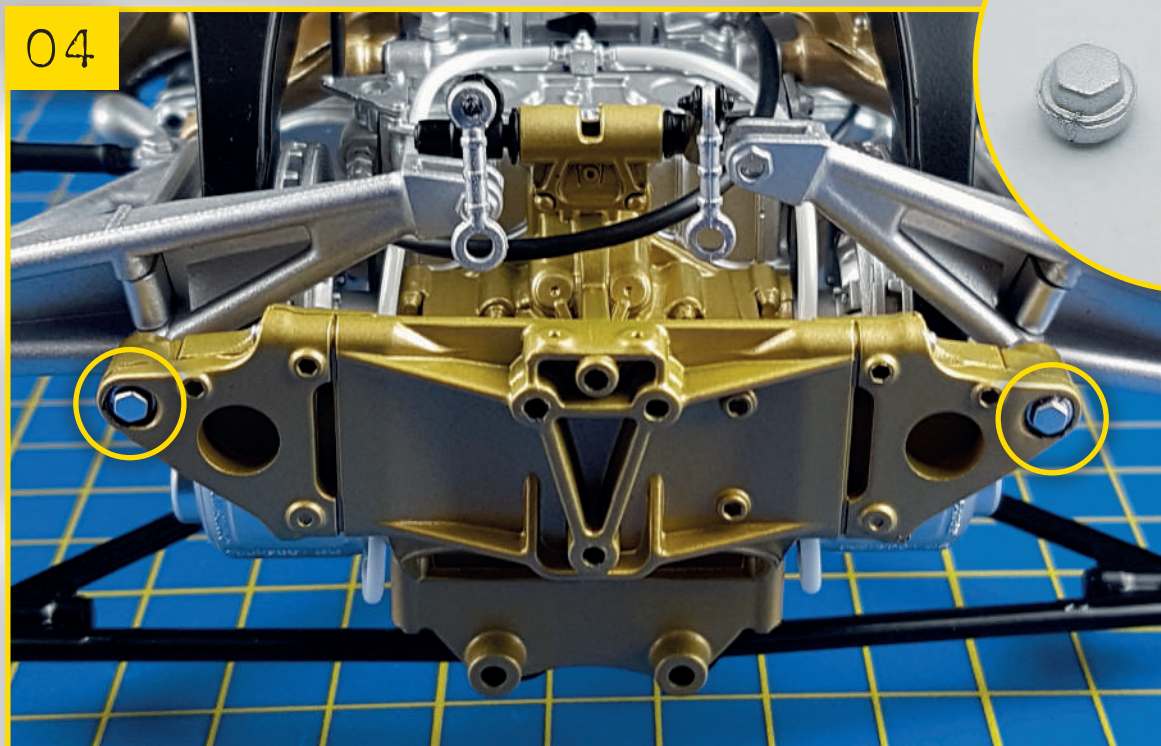

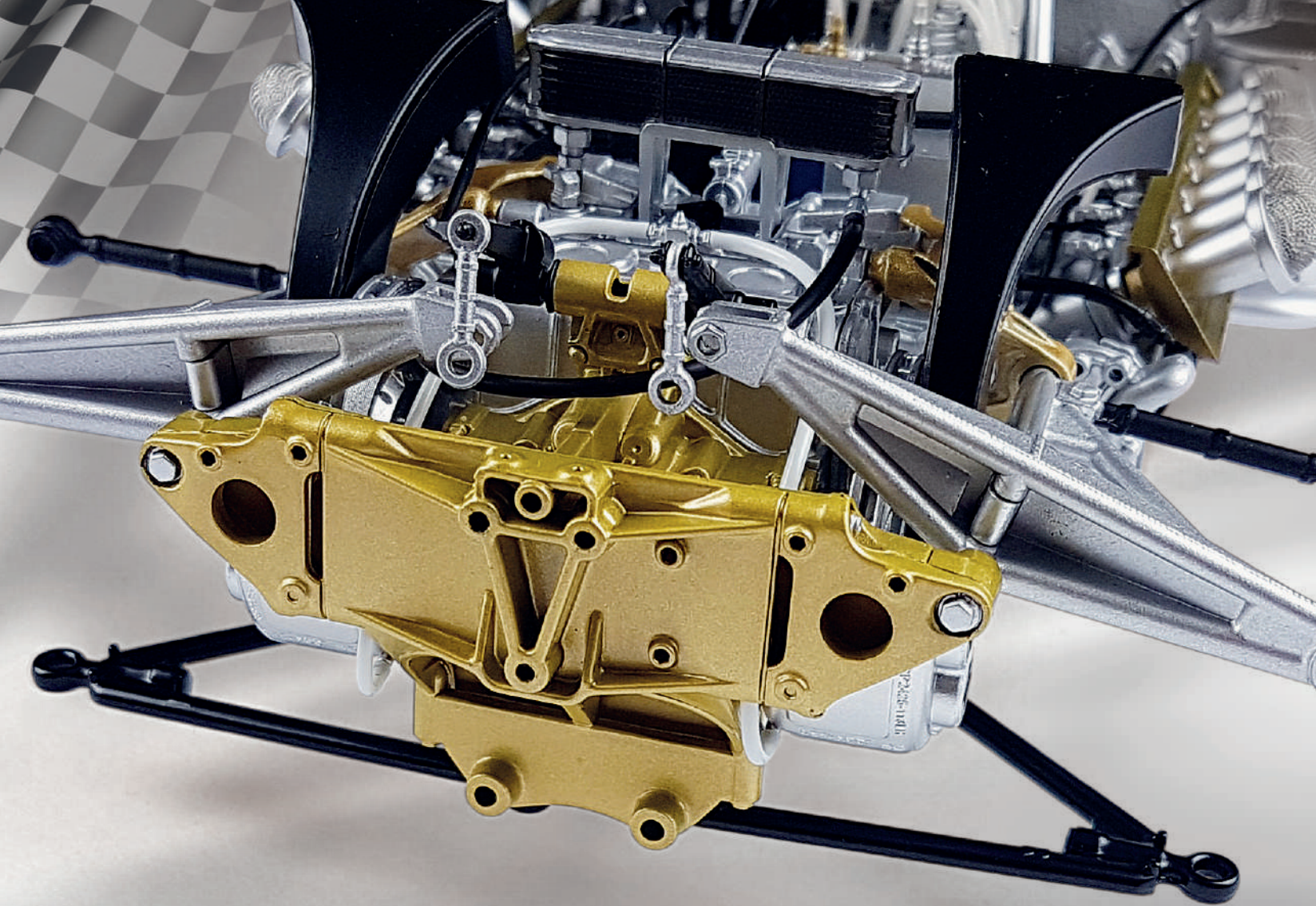

FINAL RESULT

This is how the back section of your 1:8 scale Ferrari 312 T4 will look after the suspension support has been fitted.

In the next stage

Right rear shock absorber.



RIGHT REAR SHOCK ABSORBER

THIS STAGE CONTAINS THE SECOND REAR SHOCK ABSORBER FOR YOUR MODEL. YOU CAN TEST THE OPERATION OF THE SHOCK ABSORBERS BY SQUEEZING THE TWO ENDS TOGETHER.



2 type E screws



2 type K screws



LIST OF PARTS

1 Right rear shock absorber

SCREWS

Two type E screws

Two type K screws



01

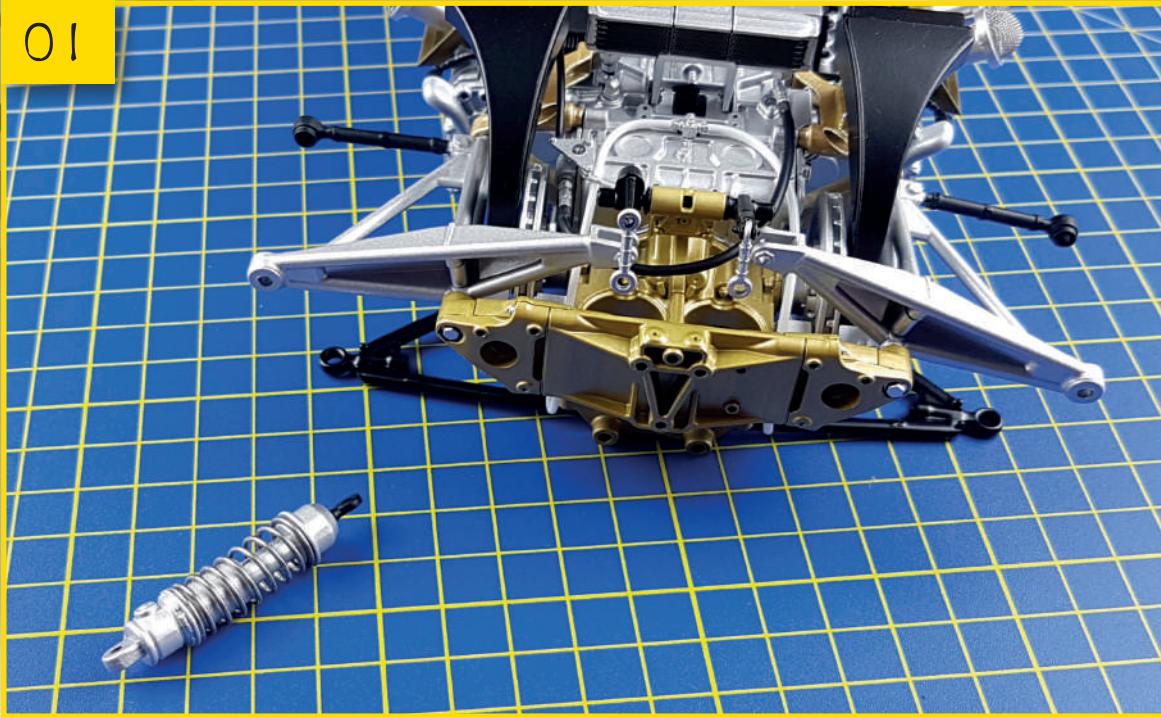

75-01 Take the left shock absorber (supplied in stage 74), together with its screws and the model.

75-02 Insert the left shock absorber into the corresponding hole with the black stem side fitting into the wishbone fork (circled).

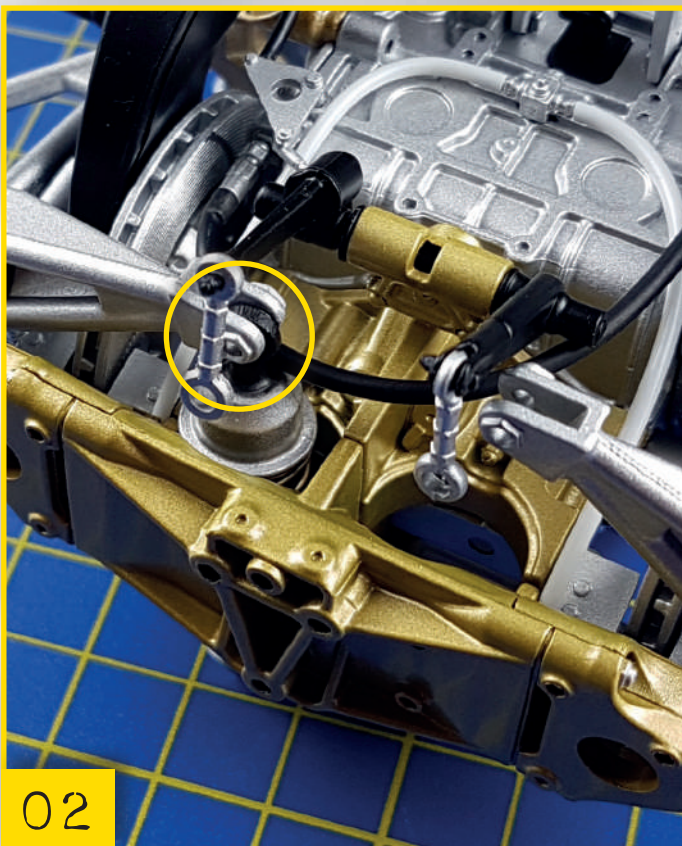

02

03

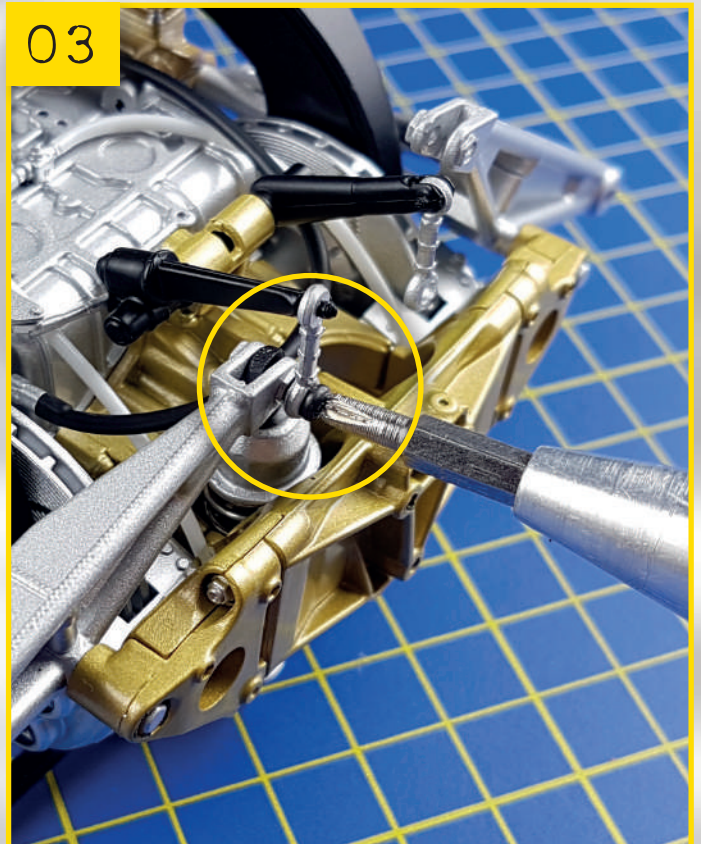

75-03 Take a type E screw and drive it into the first slot in the stabiliser bar joint, then the first part of the wishbone fork, the shock absorber and the back of the wishbone fork. Do not tighten excessively as this could damage the bar joint.

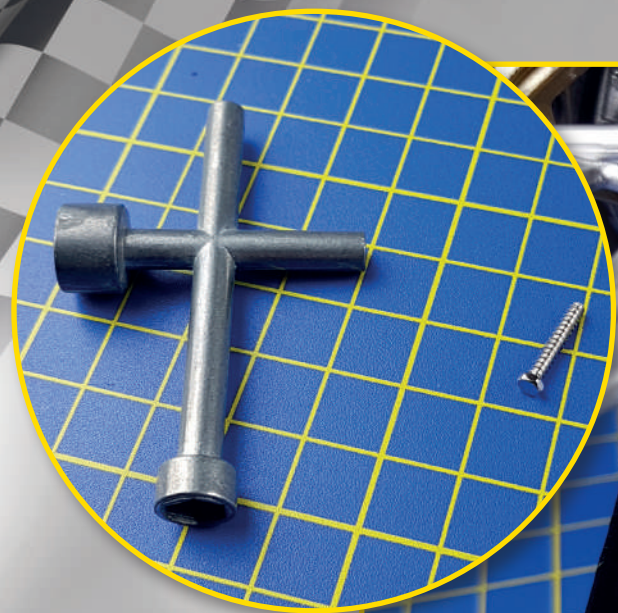

04

75-04 Take a type K screw and the socket wrench supplied to assemble the front suspensions. Insert the screw into the shock absorber head and, with the socket wrench, tighten it completely.

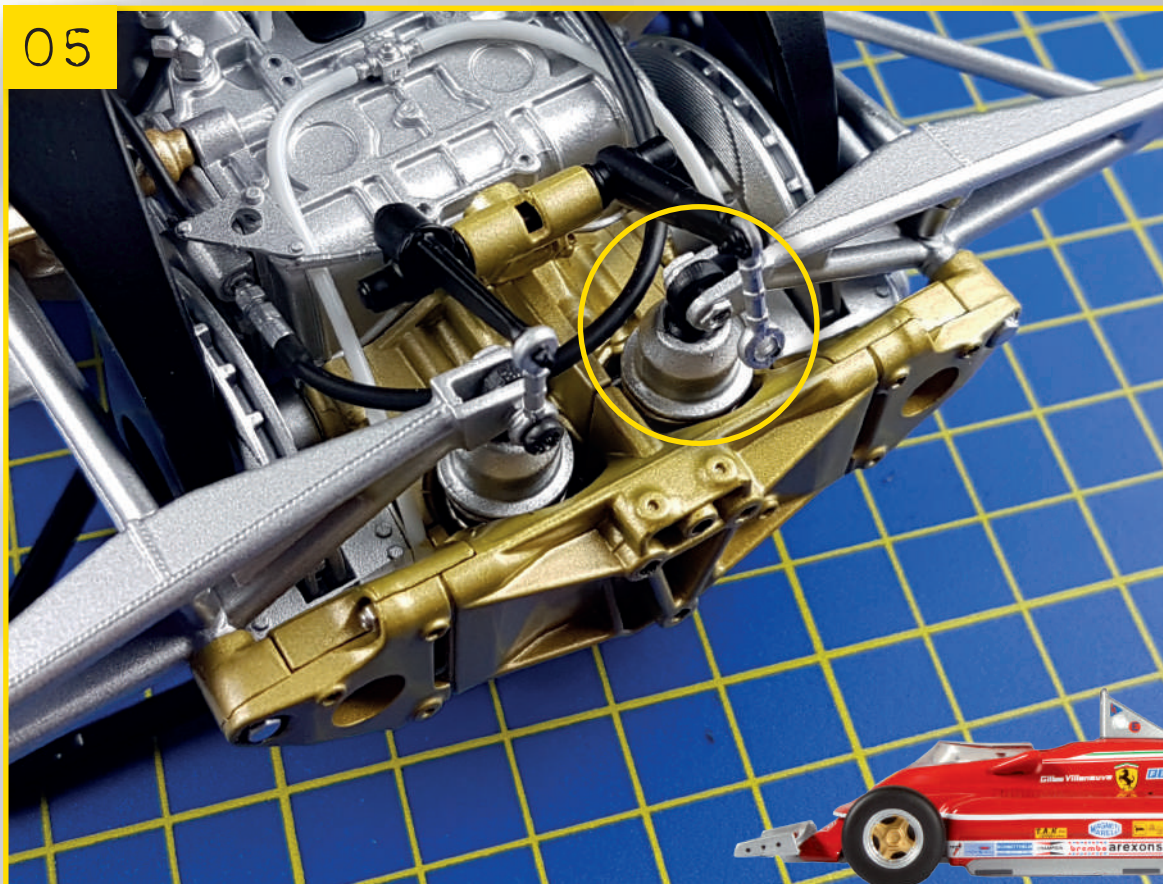

05

75-05 Now insert the right shock absorber into its housing, as illustrated in step 2.



06

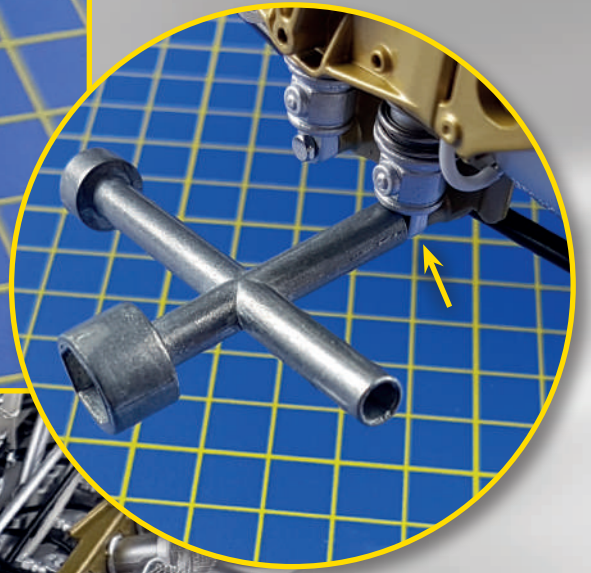
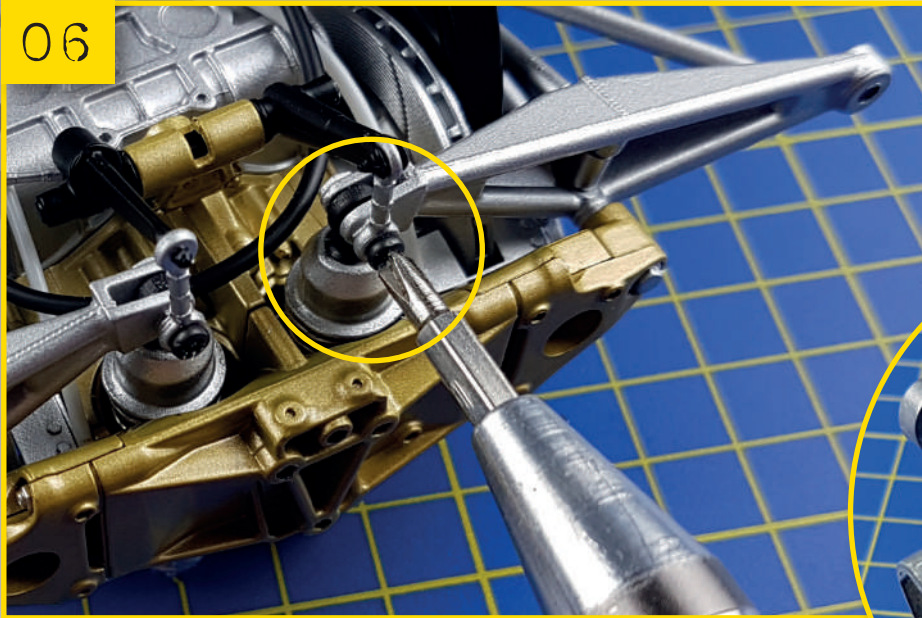

75-06 After aligning the right shock absorber, secure it in the same way as before with a type E screw at the top and a type K screw in the bottom hole, using the socket wrench.

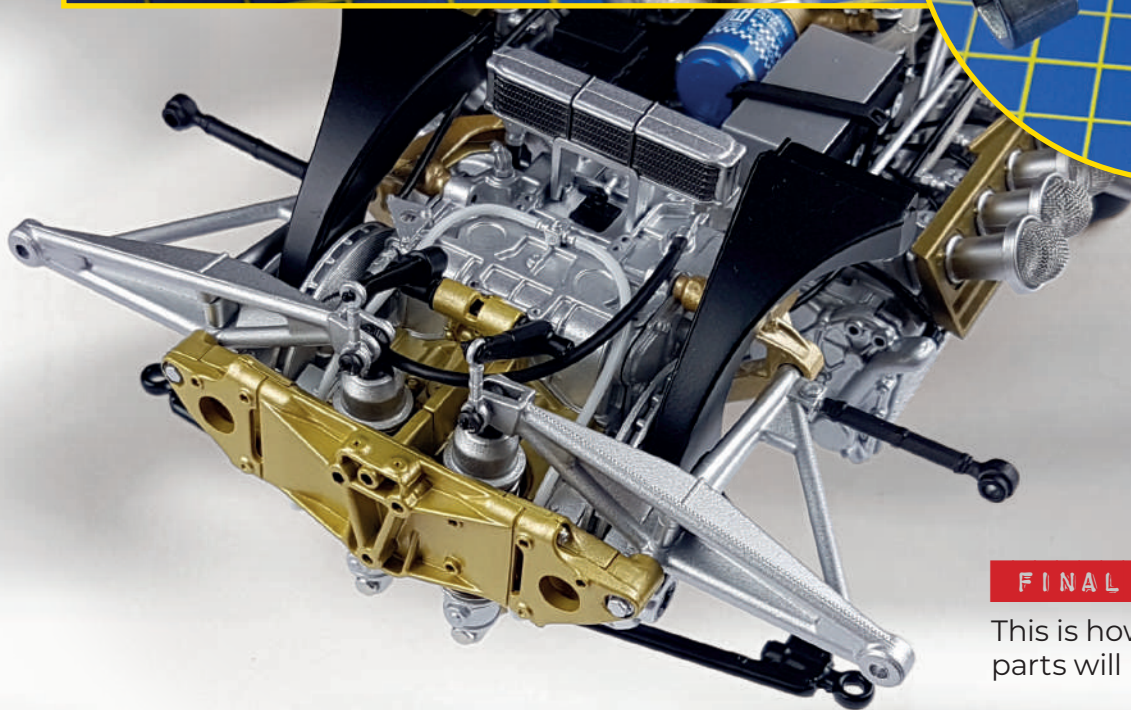

FINAL RESULT

This is how the newly installed parts will look.

In the next stage

Left rear wheel hub, semi-axle, and parts to secure and pull the rear wheel.



LEFT REAR STUB AXLE AND SEMI-AXLE

USING THE PARTS SUPPLIED YOU CAN JOIN THE LEFT REAR SEMI-AXLE TO THE MODEL AND SECURE THE STUB AXLE TO THE SUSPENSION.

IMPORTANT:
FOR ASSEMBLY, USE THE NUT COUPLING IN THE BAG MARKED "REPLACEMENT". THE LARGER CYLINDRICAL SECTION IS COMPLETELY SMOOTH.



LIST OF PARTS

- 1 Nut coupling to secure the wheel
- 2 Semi-axle connection flange
- 3 Driver
- 4 Left rear stub axle
- 5 Left rear semi-axle

SCREWS

Four type I screws



01

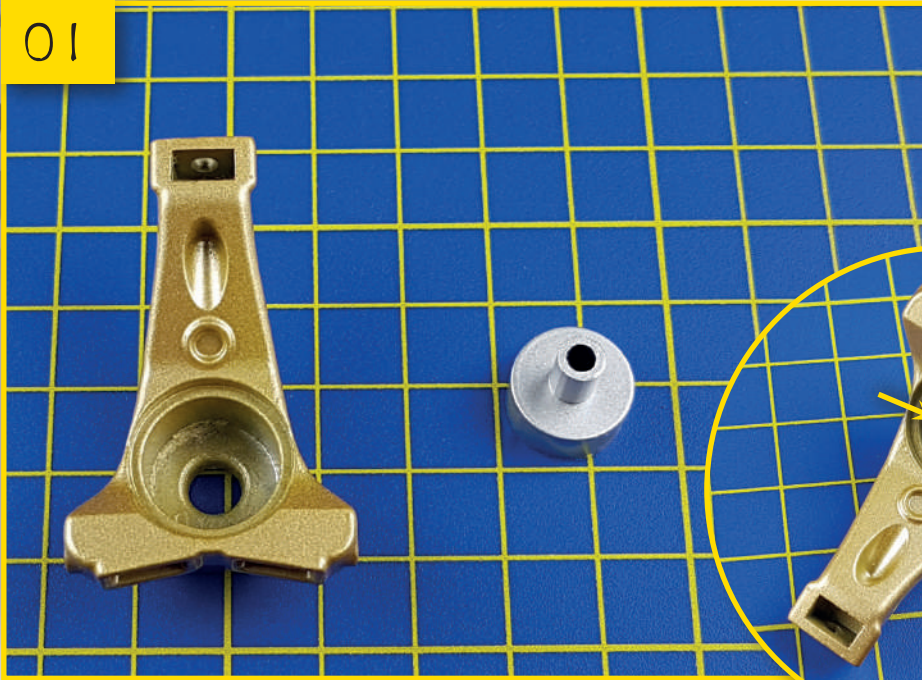

76-01 Take the stub axle and the nut coupling (from the bag marked “replacement”). Insert the nut coupling into the stub axle, so it is facing the same direction as you can see from the image.



02

76-02 Use the assembly pins to couple the flange with the joint. Look at the holes for the two pins in the inset photo of step 1.

03

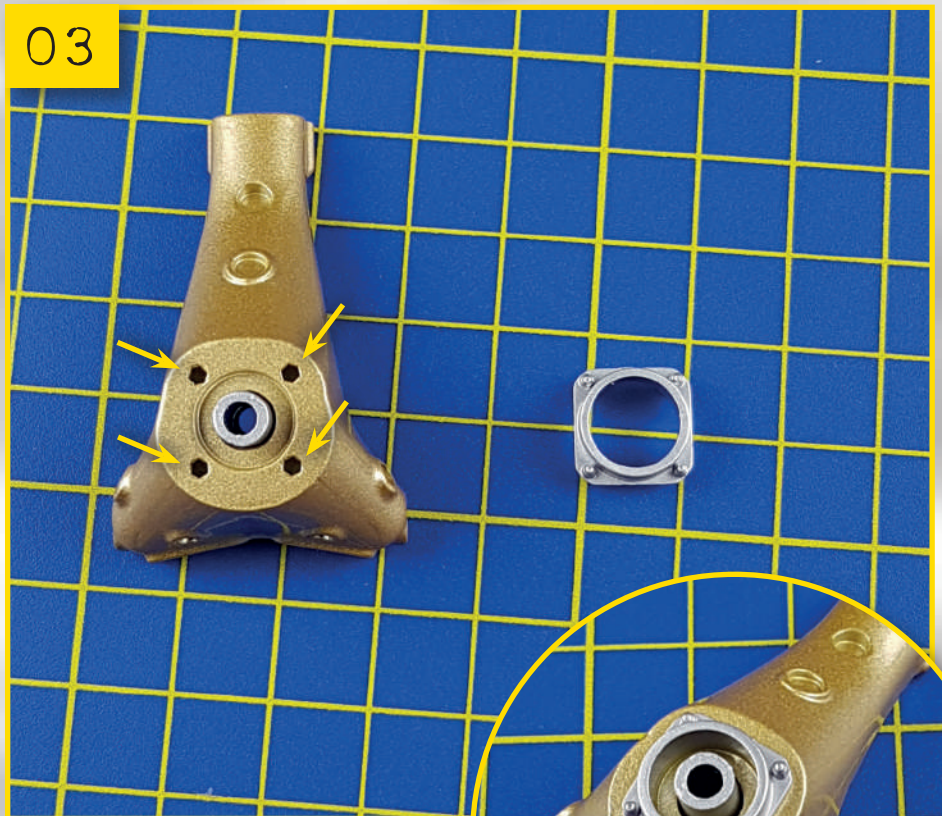

76-03 Take the driver and place it on your work surface, close to the wheel hub. Then press the driver into the front of the wheel hub, inserting the pins into the holes in the stub axle.

04

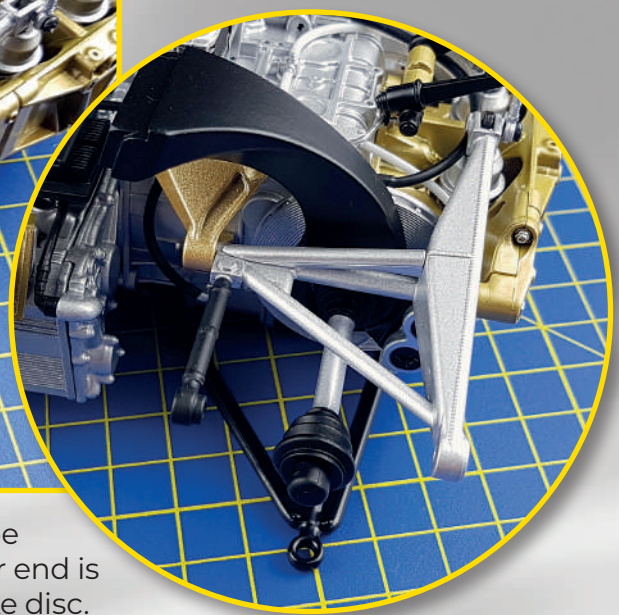
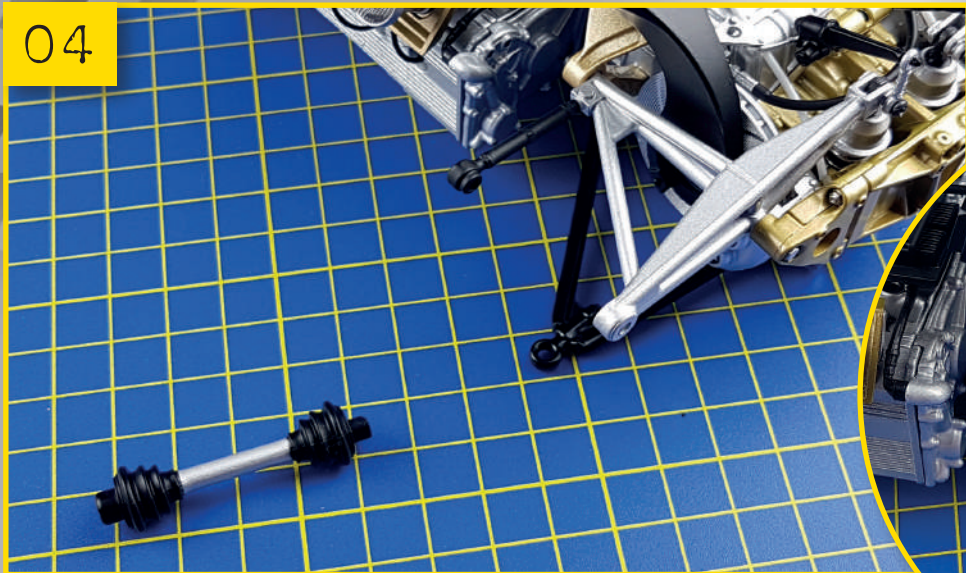

76-04 Take the left rear semi-axle. The side that needs to be fitted into the model has a semicircular pin, while the other end is cylindrical. Push the semi-axle into the hole inside the brake disc.

05

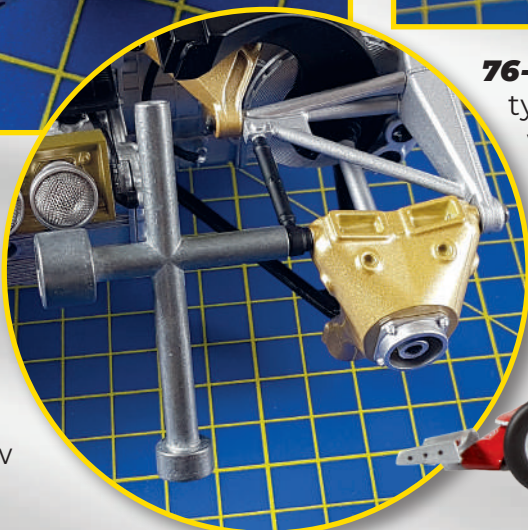

76-05 Take the stub axle and position it between the two upper wishbones. Insert the lower wishbone into the relevant hole. Use the socket wrench to tighten a type I screw as shown in the inset.

06



76-06 In the same way, secure a second type I screw into the hole of the other wishbone. Take care not to knock the mesh on the air funnel trumpets, as they could lose their shape.



07

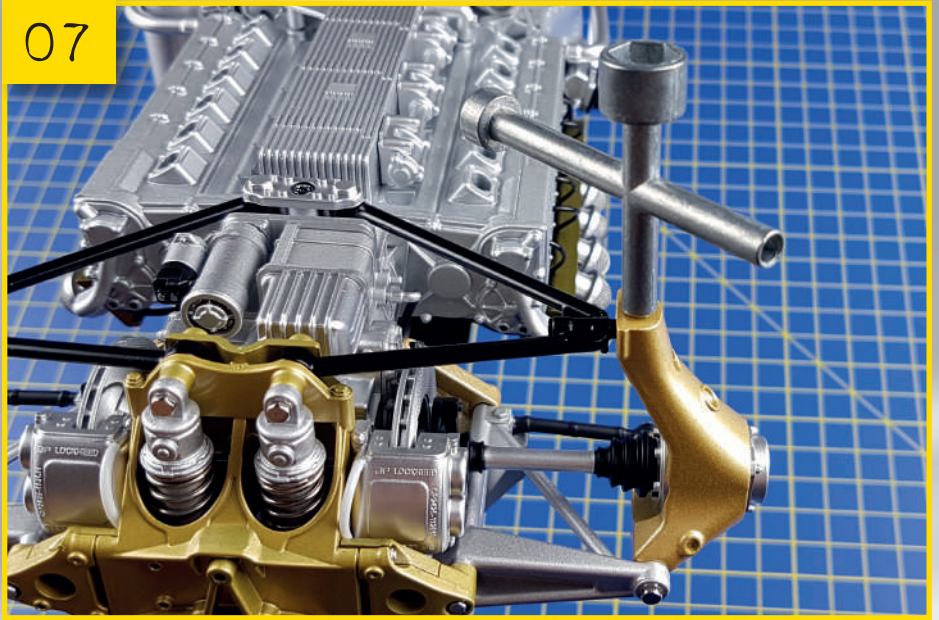

76-07 Turn the model upside down and secure the third and last type I screw into the lower part of the stub axle using the socket wrench.

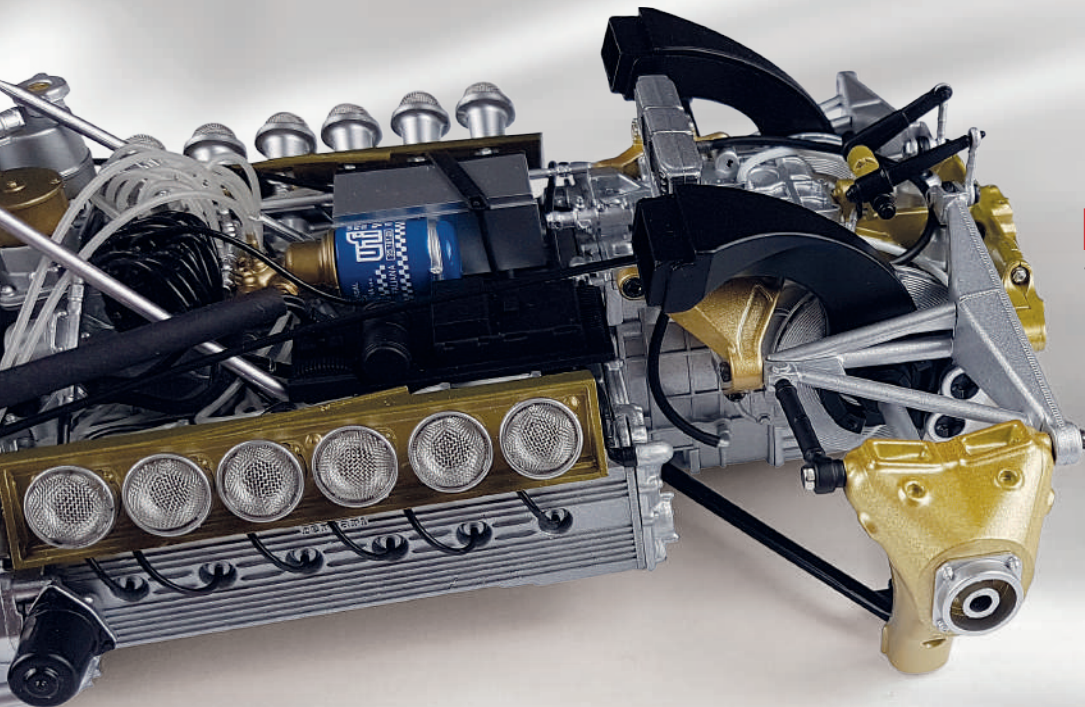

FINAL RESULT

This is how the newly installed parts will look. Place the model in a safe place.

In the next stage

The right rear wheel hub, the semi-axle and parts to secure and drive the rear wheel.



RIGHT REAR STUB AXLE AND SEMI-AXLE

WITH THE NEW PARTS, YOU CAN SECURE THE RIGHT REAR SEMI-AXLE AND JOIN THE STUB AXLE TO THE SUSPENSION.



IMPORTANT: USE THE NUT COUPLING IN THE BAG MARKED “REPLACEMENT”, WHERE THE LARGER CYLINDRICAL SECTION IS SMOOTH.

LIST OF PARTS

- 1 Nut coupling to secure the wheel
- 2 Semi-axle connection flange
- 3 Driver
- 4 Right rear semi-axle
- 5 Right rear stub axle

SCREWS

Four type I screws



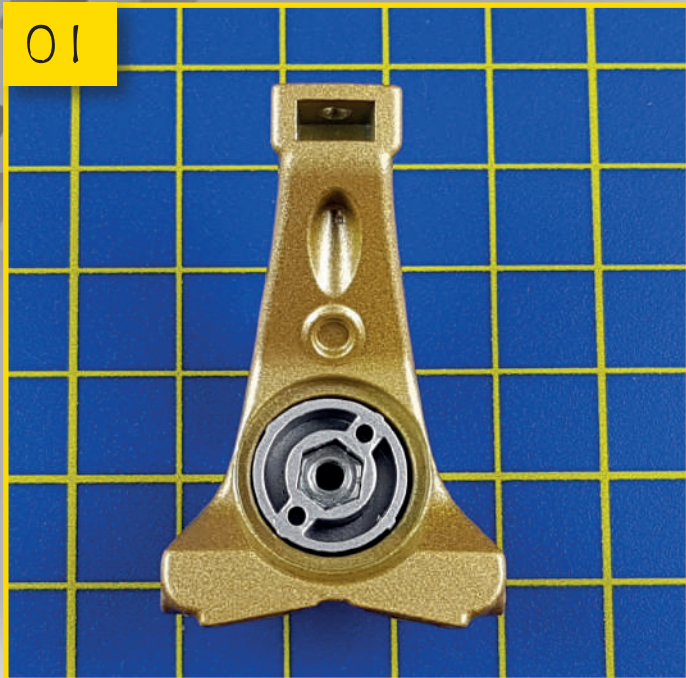

01

77-01 Take the stub axle and the nut coupling. Insert the nut coupling into the stub axle, facing the same direction as shown.



02

77-02 Use the assembly pins and holes to couple the flange with the joint.

77-03 Fit the drive to the outer part of the stub axle. The drive presses into place with four pegs, which need to be inserted into the relevant holes in the stub axle.

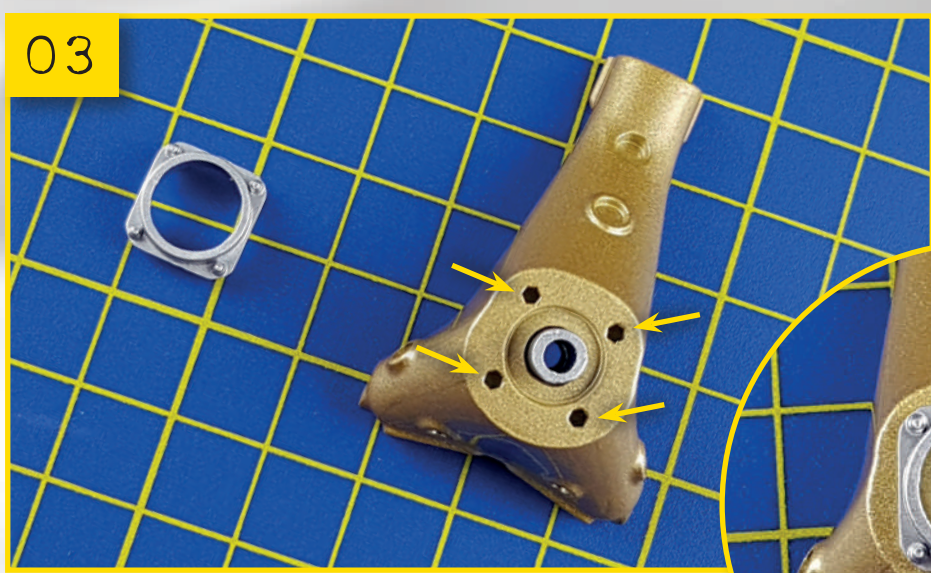

03

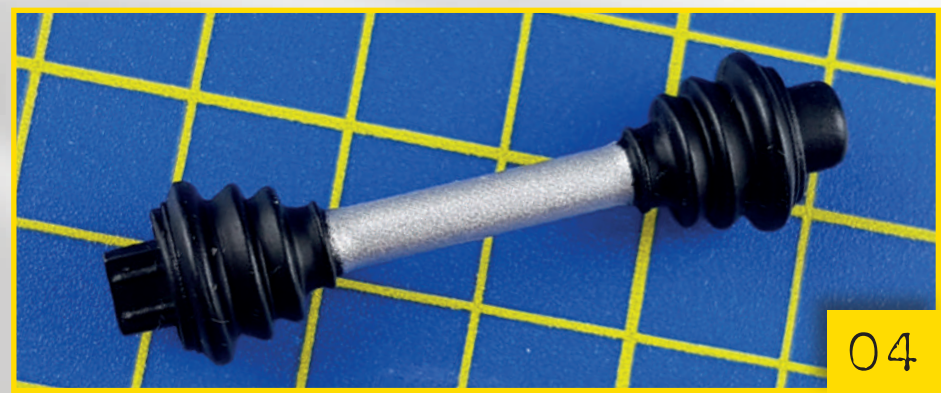
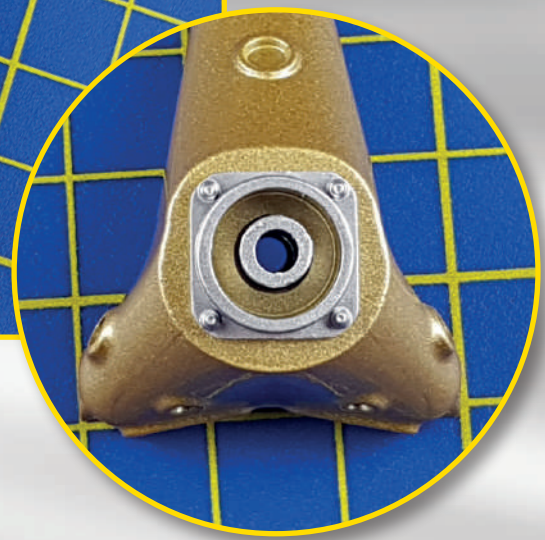

04

77-04 The semi-axle has two ends. The end with a semicircular section must be inserted into the centre of the brake disc.

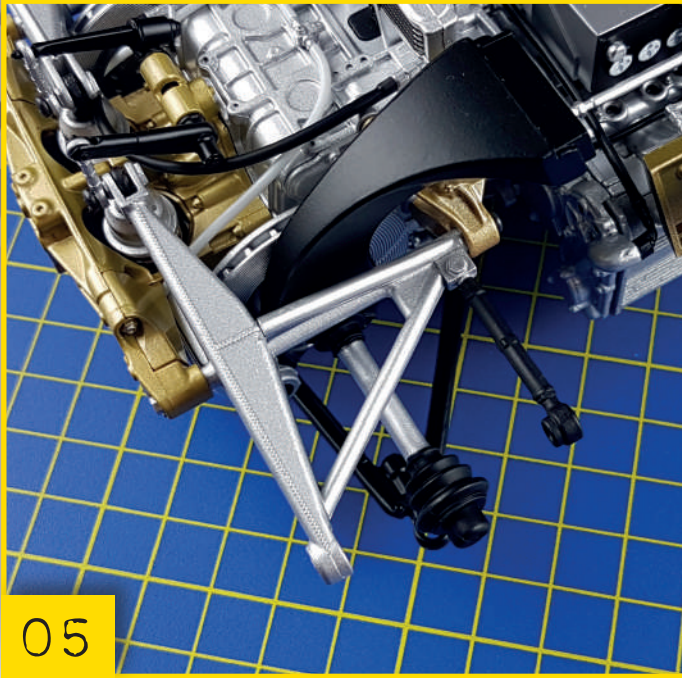

05

77-05 Insert the semicircular end of the right rear semi-axle into its seat.

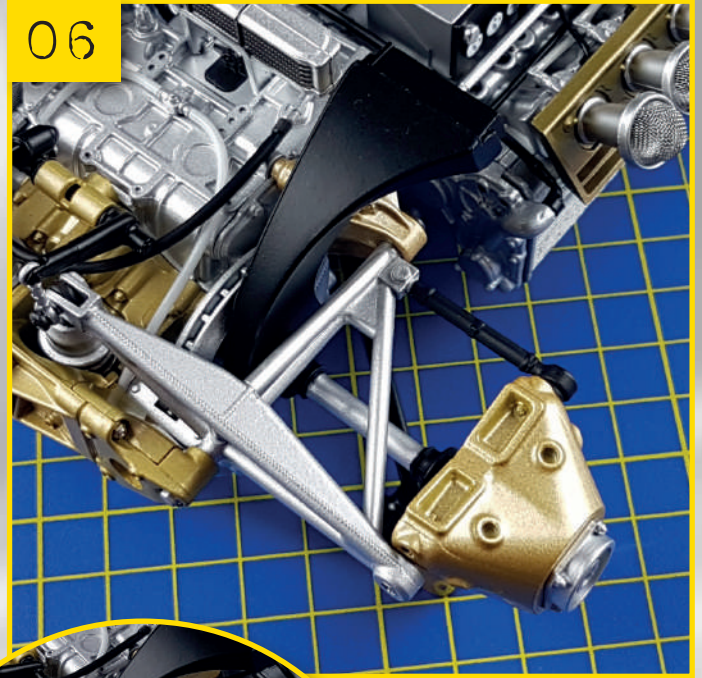

06

77-06 Now position the right stub axle between the wishbones of the relevant suspension. Insert the lower wishbone into the hole at the base of the stub axle., then tighten a type I screw into the first upper wishbone.

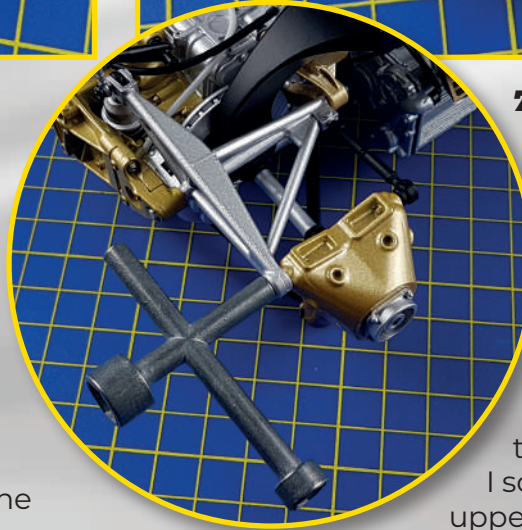

77-07 Use a second type I screw to join the other upper wishbone of the stub axle.

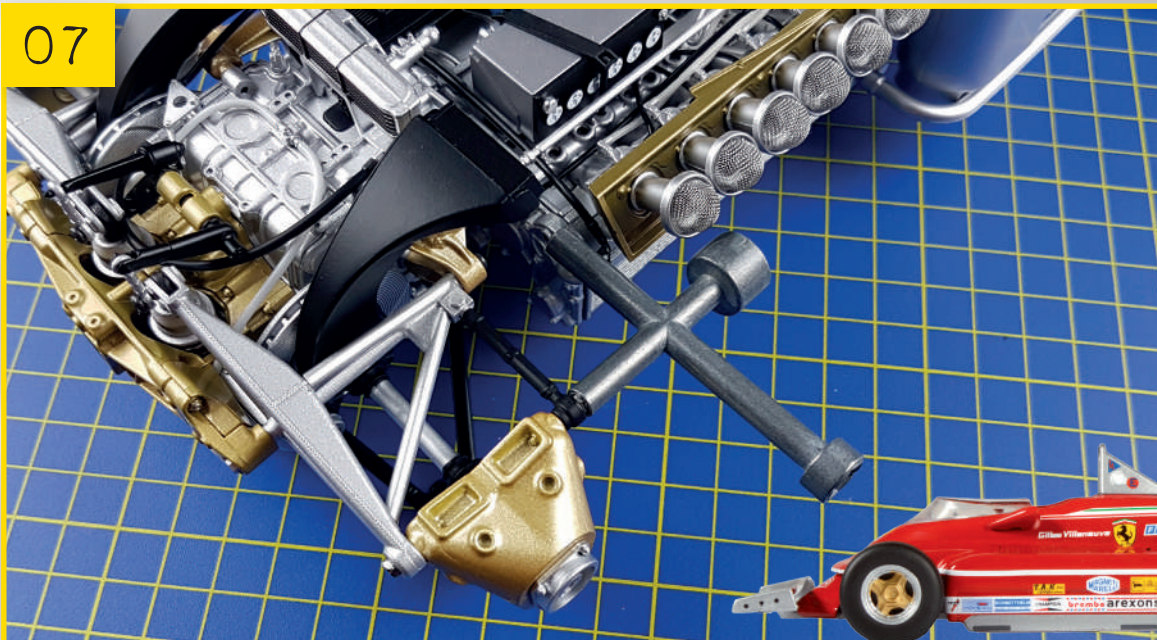

07



08

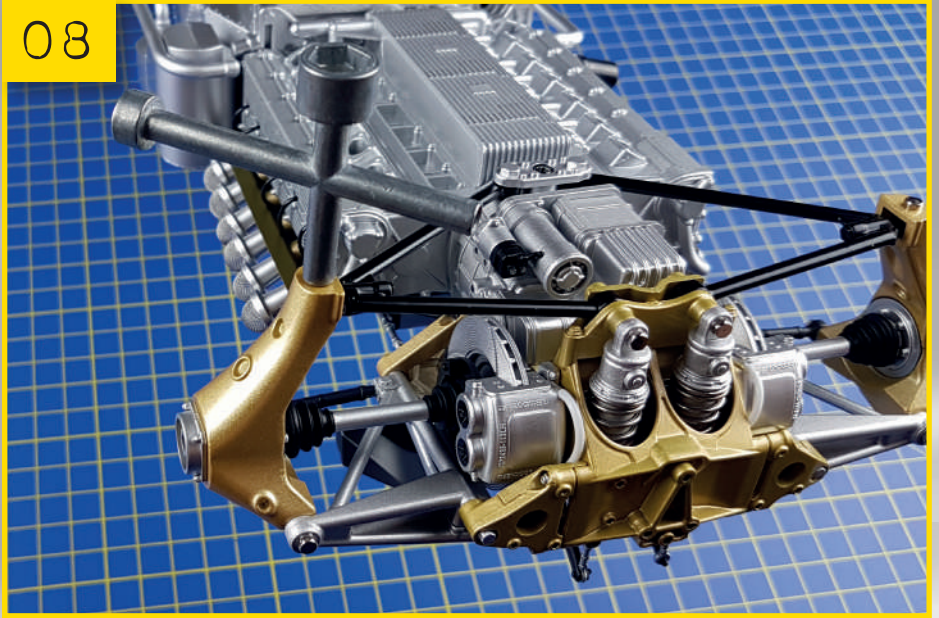

77-08 Then turn the model over and with the last type I screw, secure the stub axle to the bottom wishbone suspension.

FINAL RESULT

Now the two stub axles are joined to the model. Place the model in a safe place.

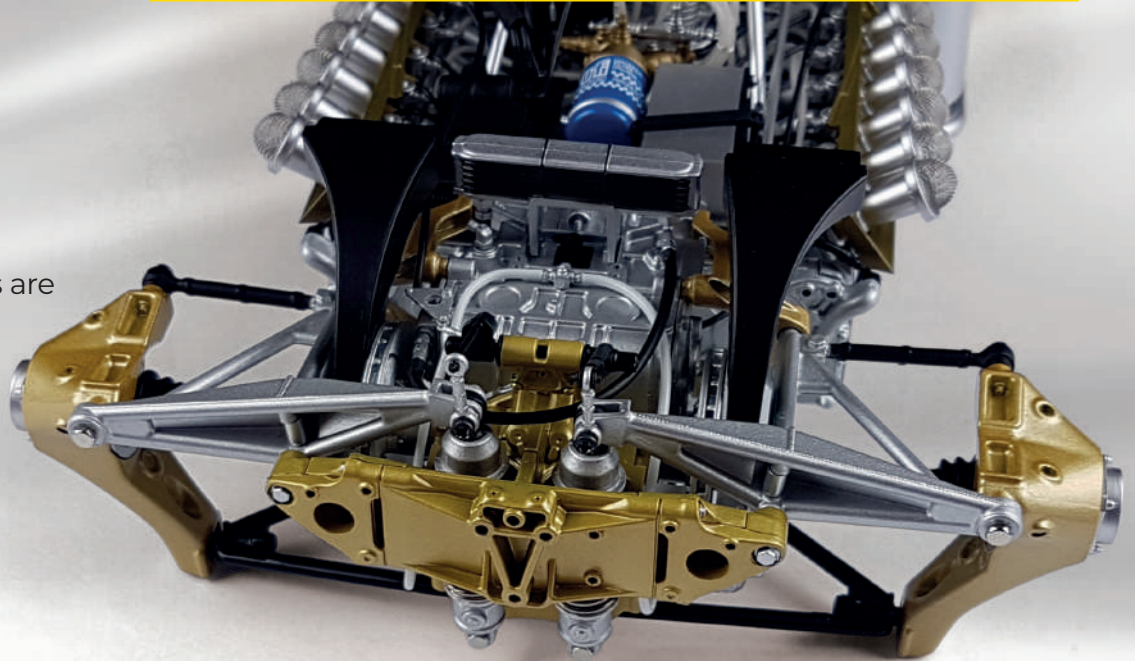

In the next stage

The next stage will include the left rear tyre and its filler.



LEFT REAR TYRE

THIS STAGE CONTAINS THE LEFT REAR TYRE, WHICH WILL BE ATTACHED IN THE NEXT STAGE. FOR NOW YOU'LL BE INSTALLING THE REAR WING ONTO YOUR FERRARI 312 T4 MODEL.



LIST OF PARTS

- I Left rear tyre



01

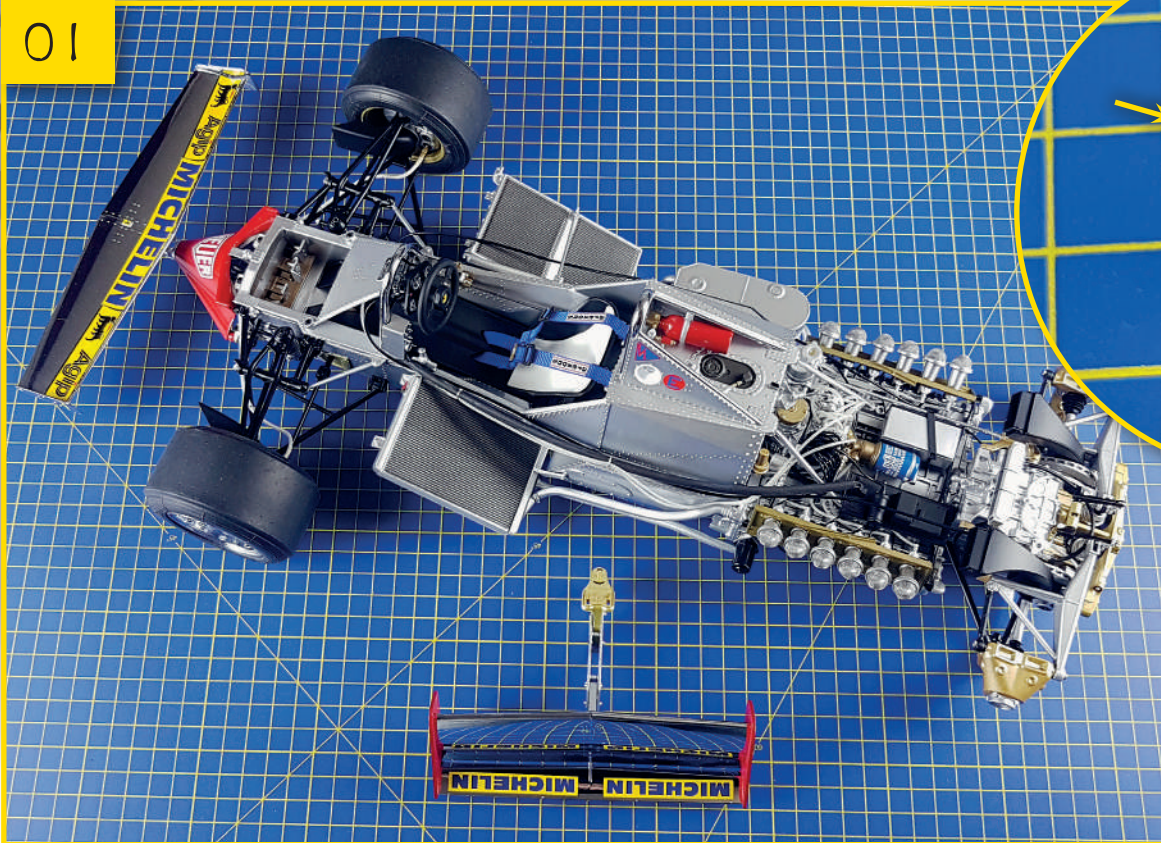

78-01 Place the model and the rear wing on your work surface. As you can see, the support plate for the wing has four pins (inset), one on the bottom and three on the support, with false bolts.

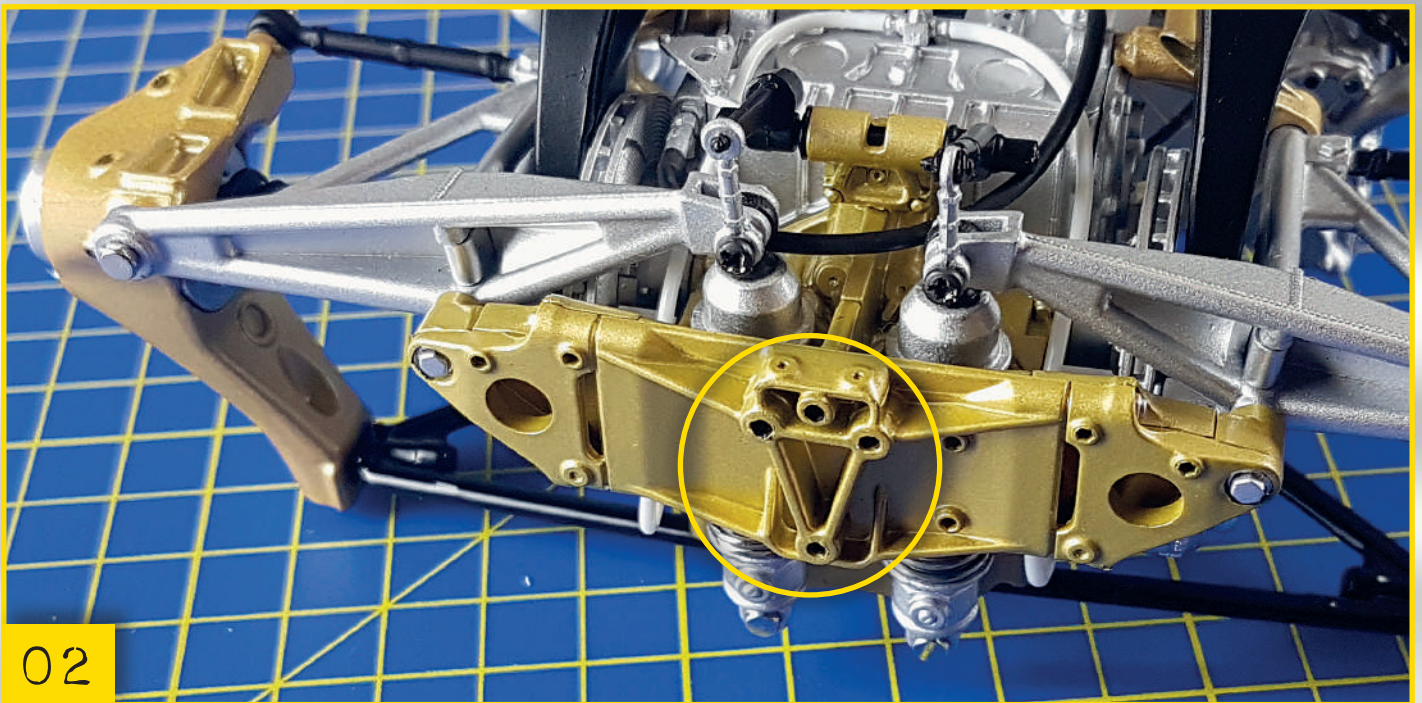

02

78-02 At the rear part of your model, on the support for the suspension wishbone and shock absorber cover, there are four holes; their positions correspond to the pins on the wing.

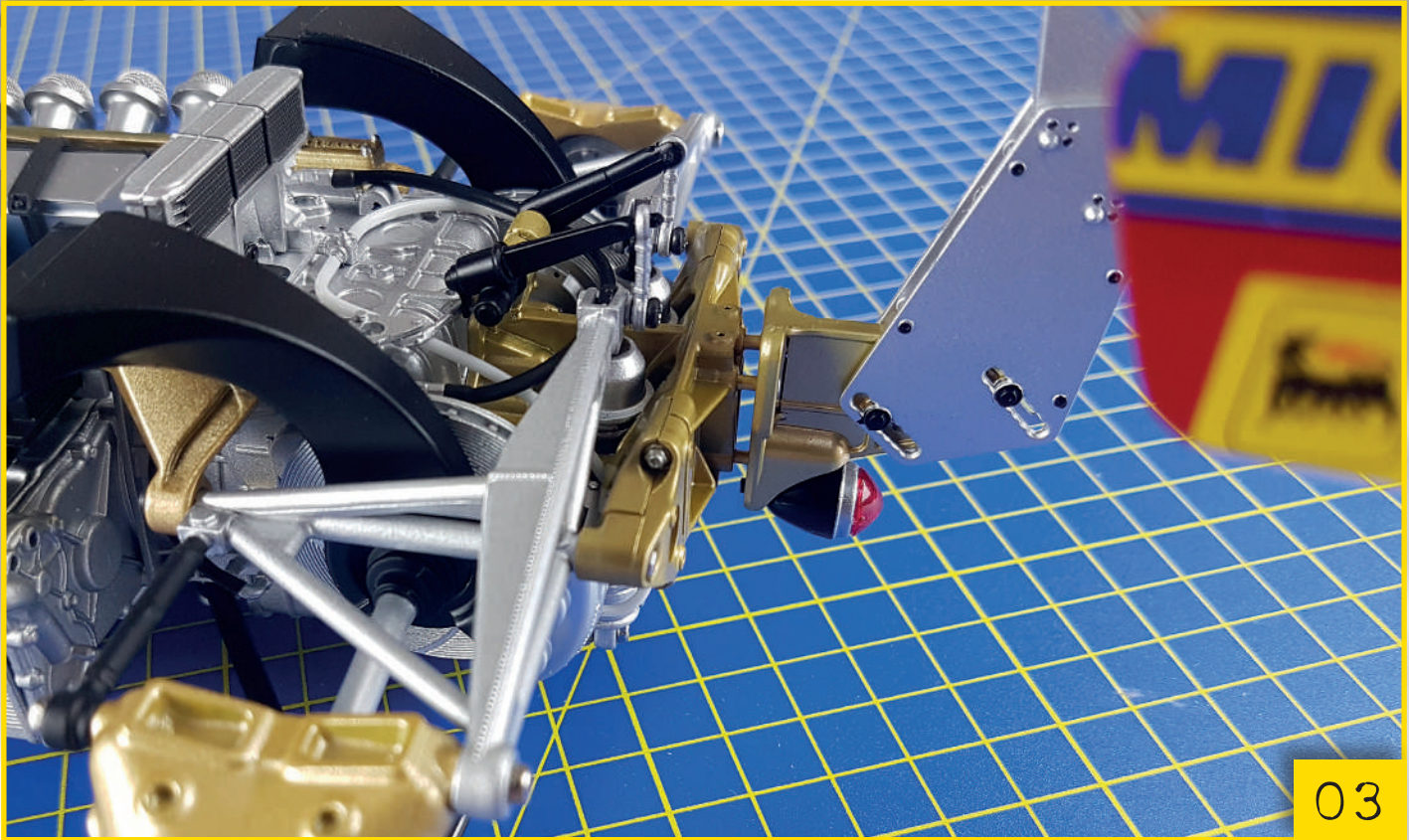

78-03 Place the wing so that the four pins are aligned with the holes. Do not insert these elements all the way, just put them in place.

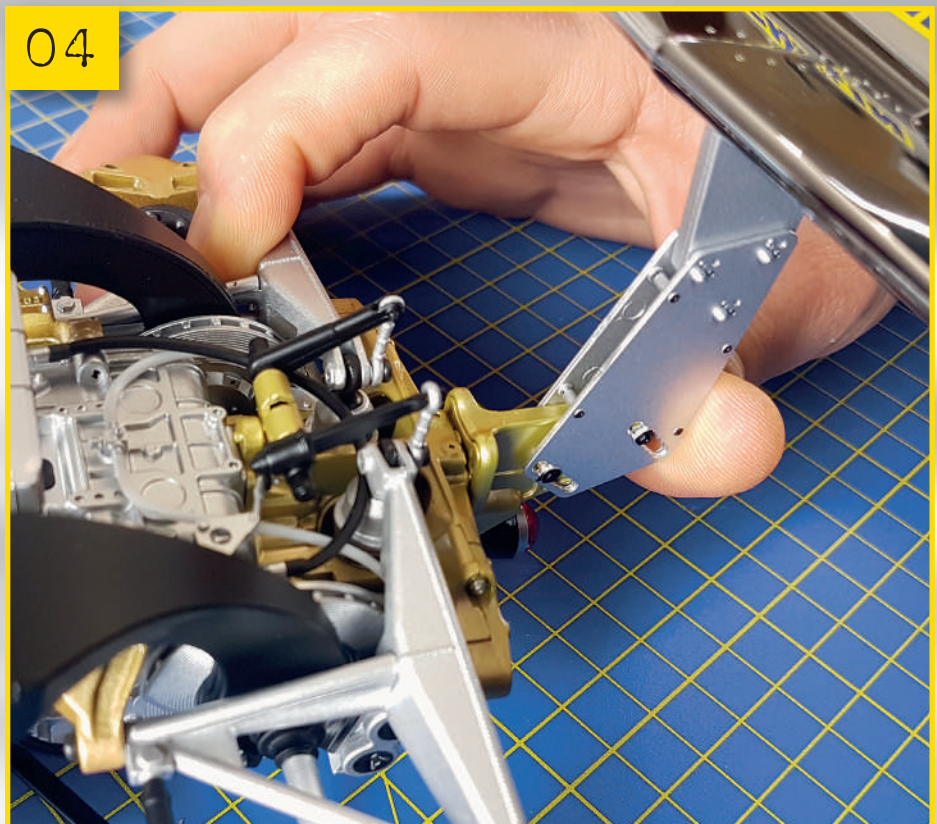

78-04 At this point, use your hand as a lever between the right upper suspension wishbone and the vertical upright of the wing, pressing between the two parts to insert the pins all the way into the holes. Use the right wishbone and then the left one to help you, alternating the pressure so that the wing is perfectly aligned on its support structure.

FINAL RESULT

The rear wing has been attached to the model.

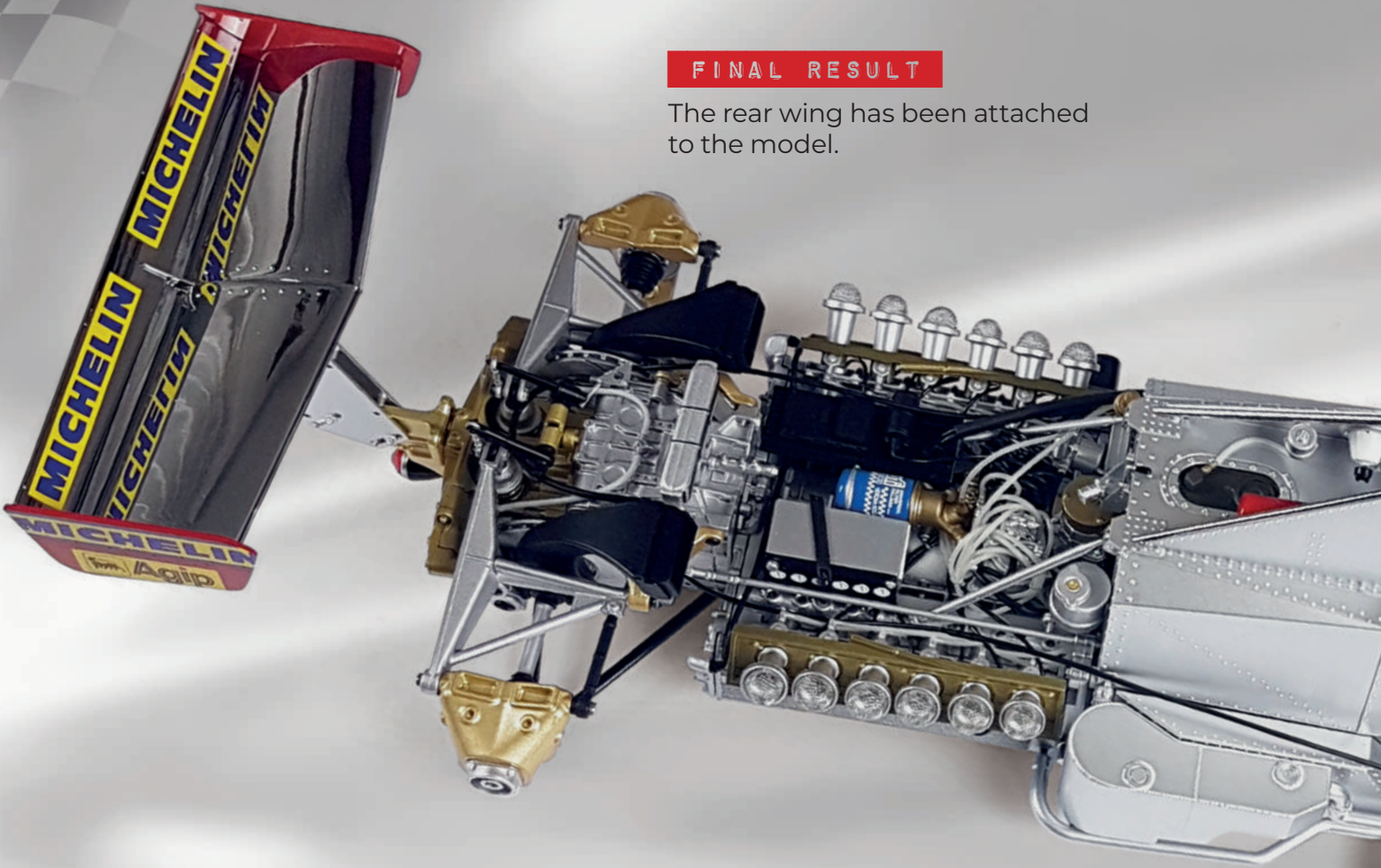

In the next stage

Components for the left rear rim.



COMPONENTS FOR THE LEFT REAR RIM

THE REAR WHEEL RIMS ON YOUR 1:8 SCALE FERRARI F312 T4 CONSIST OF SEVERAL PARTS. THIS STAGE HAS THE PIECES FOR THE LEFT-SIDE RIM, WHICH YOU'LL ASSEMBLE READY FOR FITTING THE LEFT REAR TYRE IN STAGE 80.



3 type A screws



2 type L screws



LIST OF PARTS

- 1 Rear rim closure
- 2 Rim body
- 3 Hubcap
- 4 Five security pins

SCREWS

- Three type A screws
- Two type L screws



01

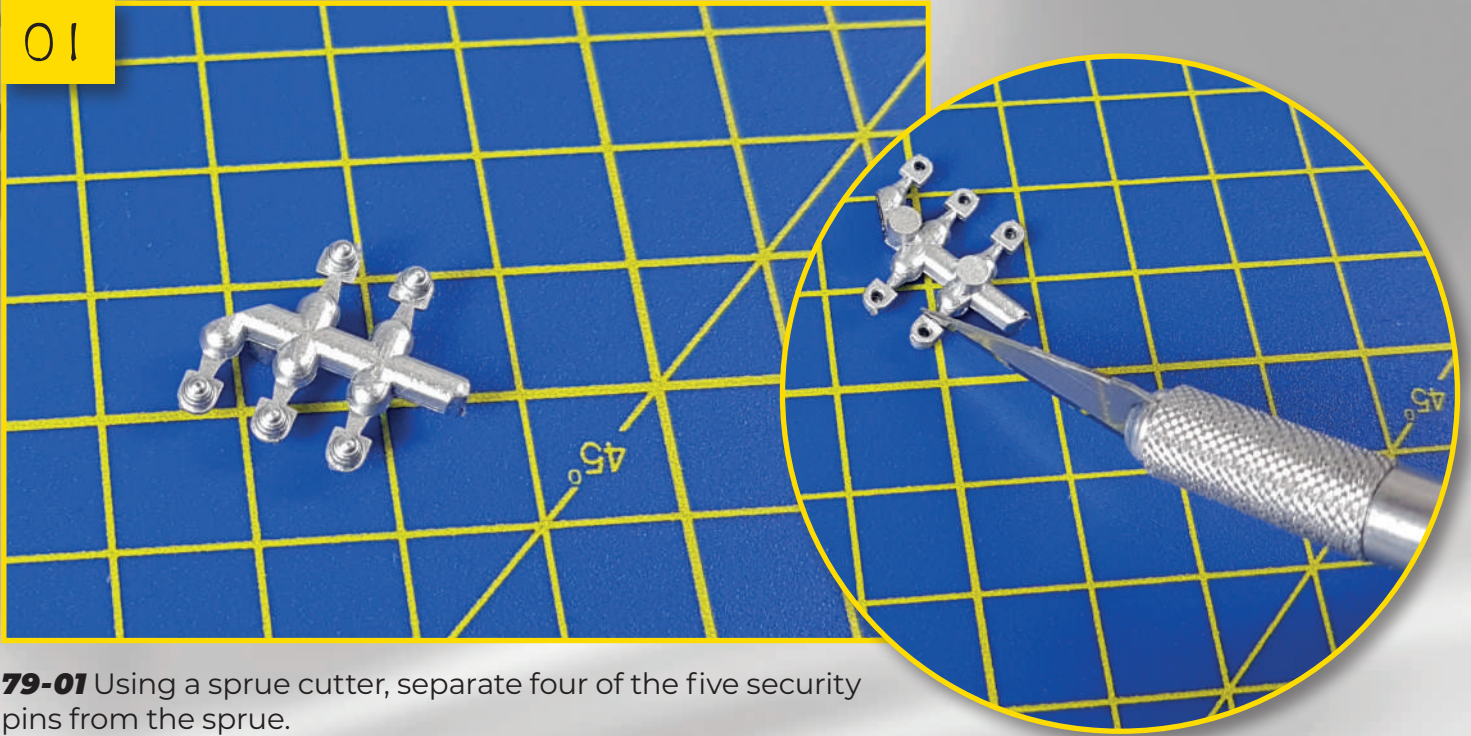

79-01 Using a sprue cutter, separate four of the five security pins from the sprue.

02

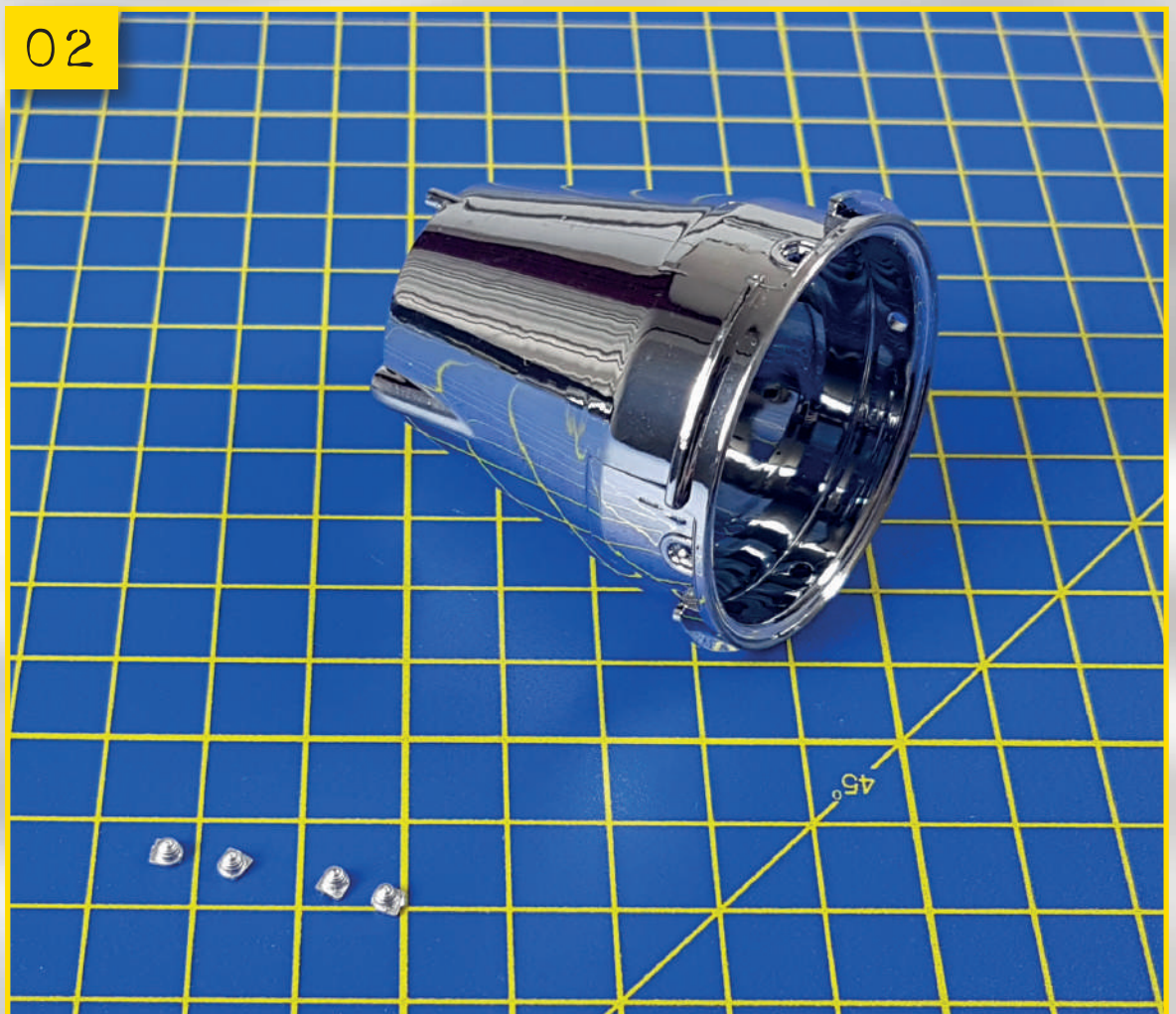

79-02
Now take the body of the left rear rim.

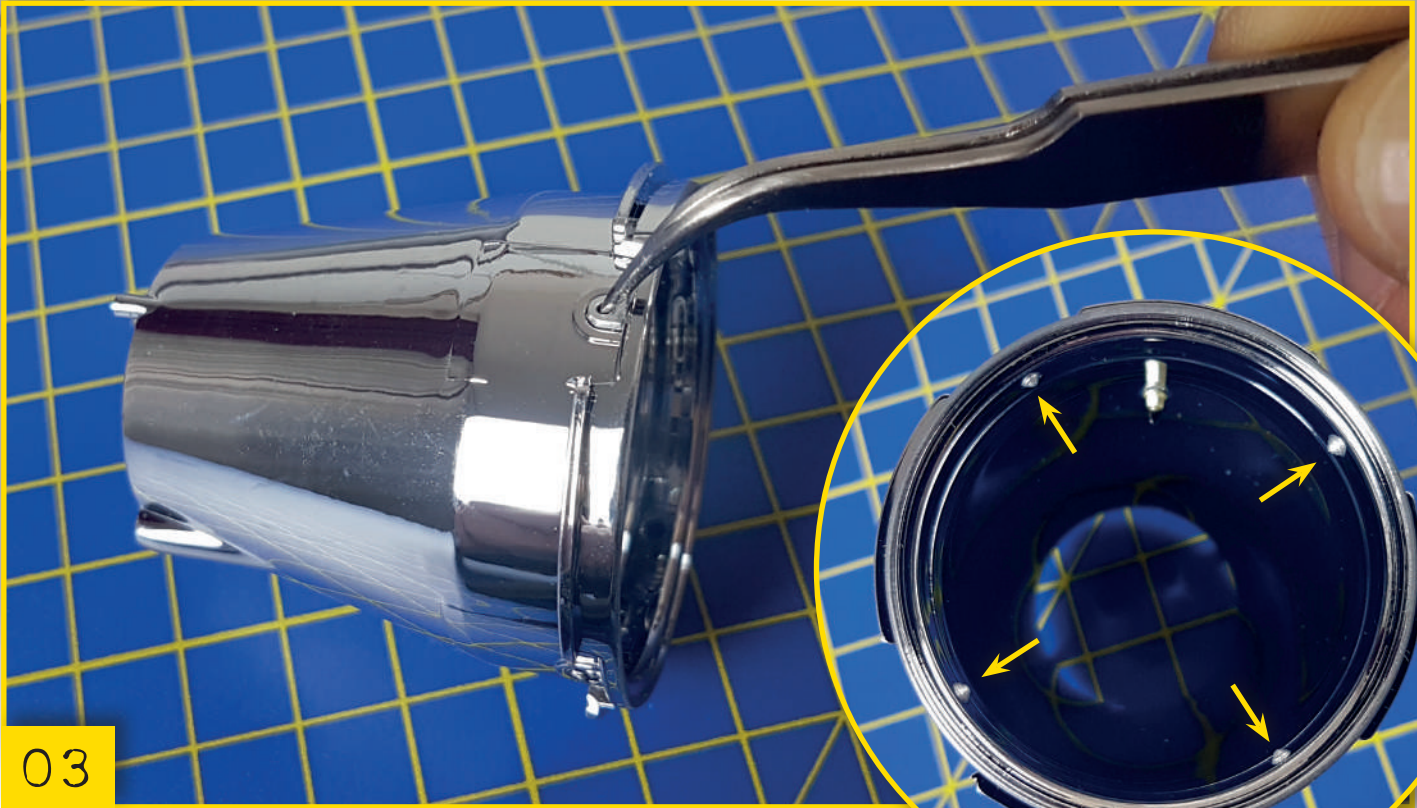

03

79-03 Use tweezers to fit the four small security pins along the outer surface of the rim. Their rounded ends need to project into the part (inset image).



04

79-04 Fit the rear closure onto the rim body. In the image, the two centring pins are highlighted (arrows), as are the two seats of the assembly screws (circles).



05



79-05
Insert and tighten the two type A screws in the seats.

FINAL RESULT

The left rear wheel rim is now almost completely assembled. Carefully put the hubcap and type L screws to one side, ready to be fitted later.



In the next stage

The right rear tyre and its filler insert.



RIGHT REAR TYRE

STAGE 80 SUPPLIES THE RIGHT REAR TYRE, COMPLETE WITH THE FOAM INSERT TO MAKE IT LOOK INFLATED. CAREFULLY SET IT TO ONE SIDE FOR LATER USE. FOLLOW THE INSTRUCTIONS FOR THIS STAGE TO INSTALL THE LEFT REAR WHEEL ON YOUR MODEL.



LIST OF PARTS

- 1 Right rear tyre



01

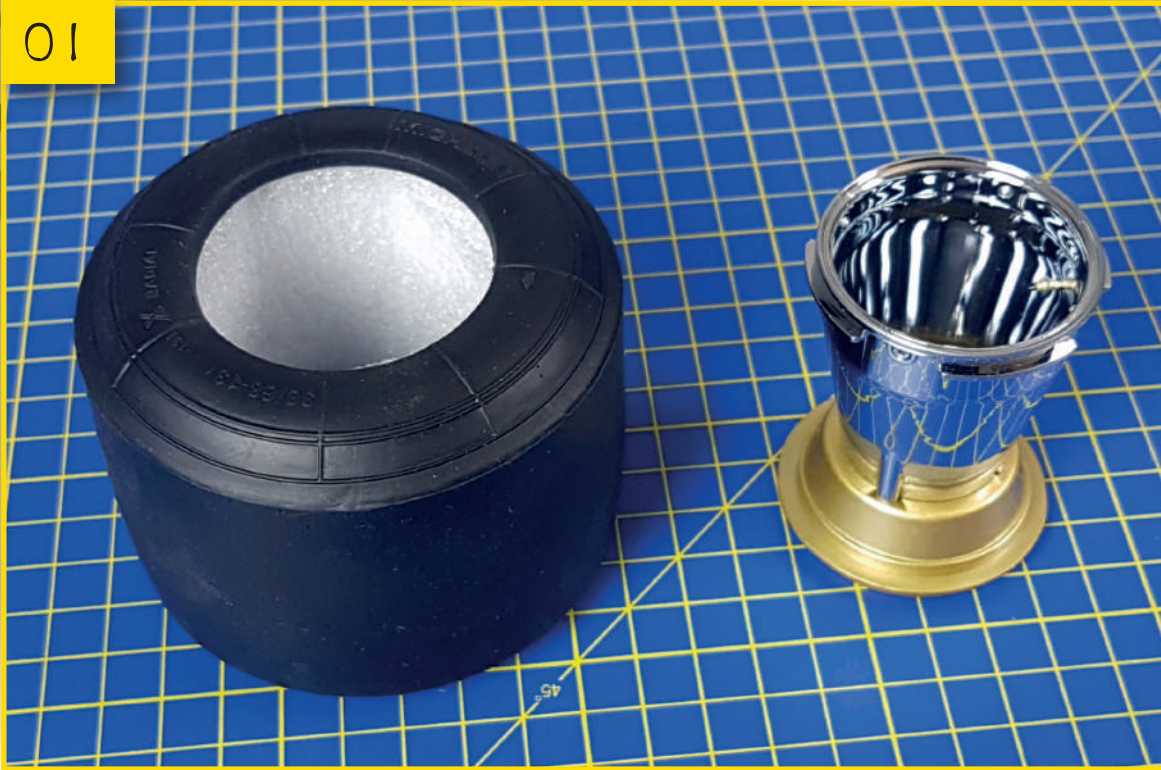

80-01
Place the left rear tyre (stage 78) and the rear rim assembled in the last stage on your work surface.

02

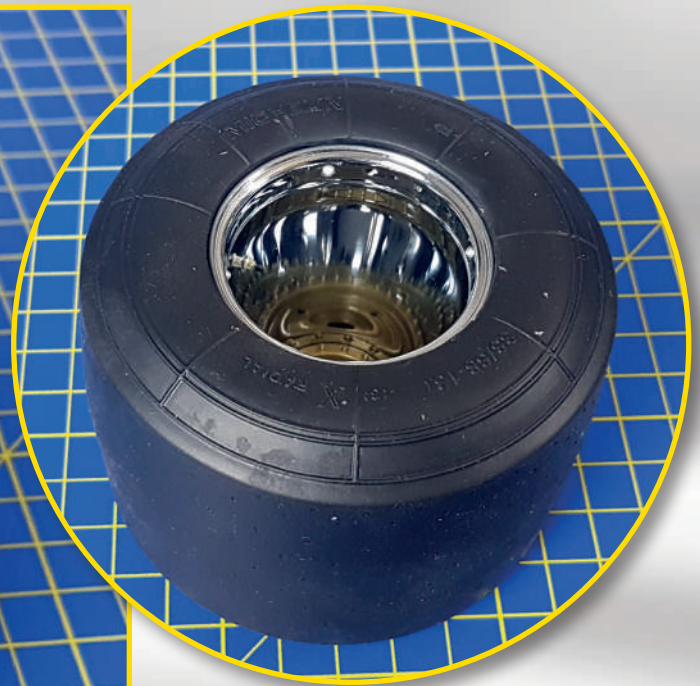

80-02
Insert the rim in the tyre. Make sure the tyre lips perfectly match with the rim on both sides of the wheel.

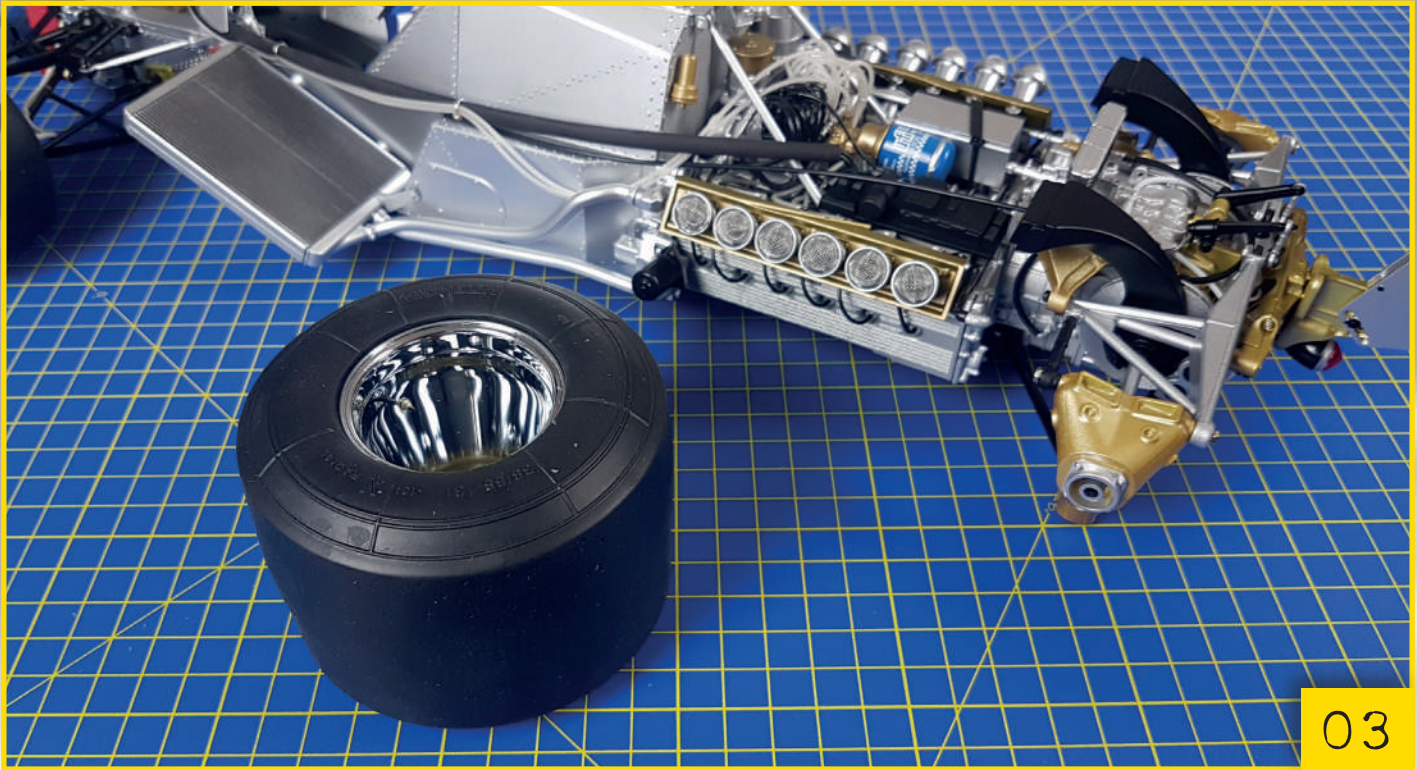

80-03 Take the model and place it so that it is easy to access and work on the rear left side.

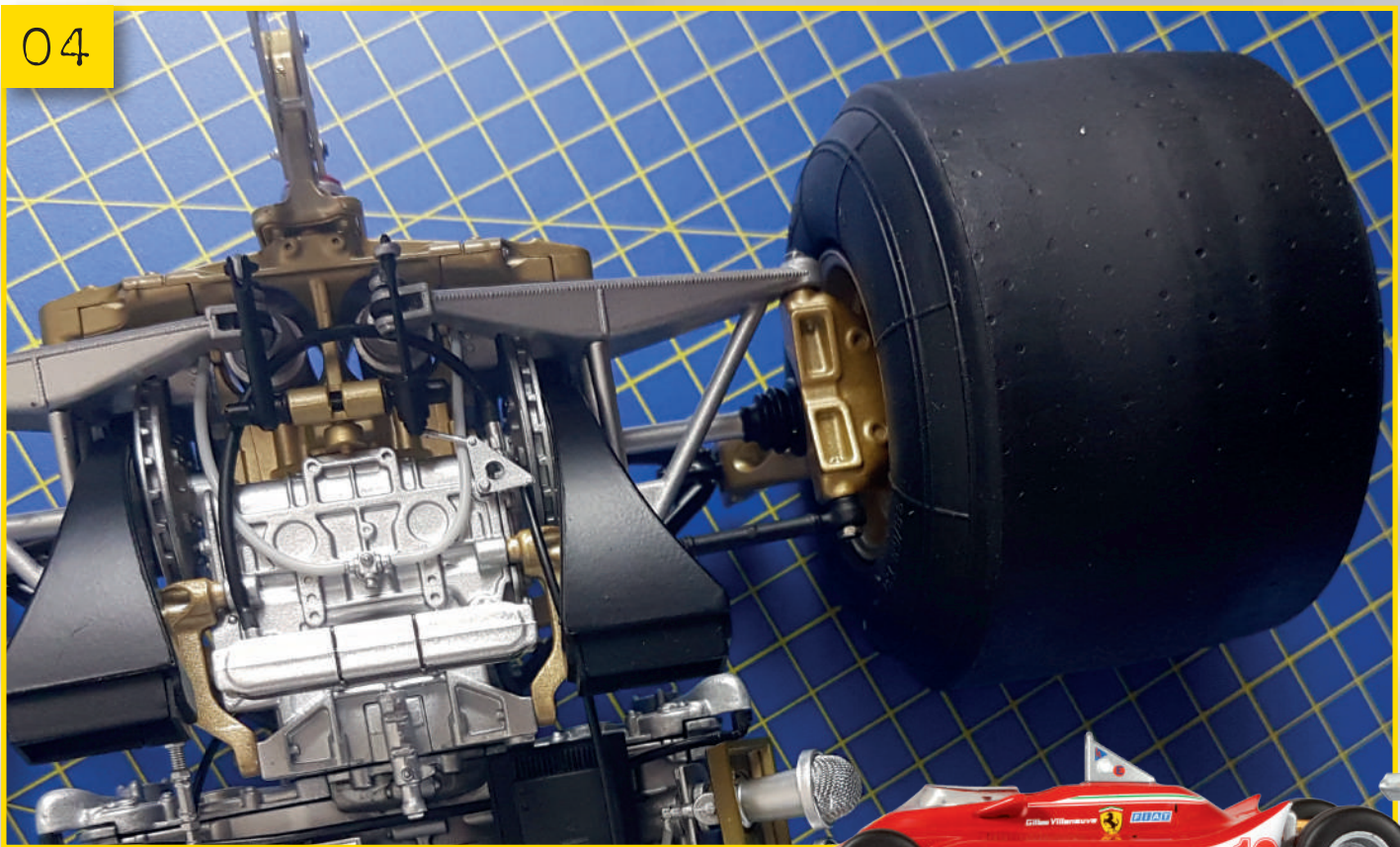

80-04
Press the wheel onto the left rear hub.

05

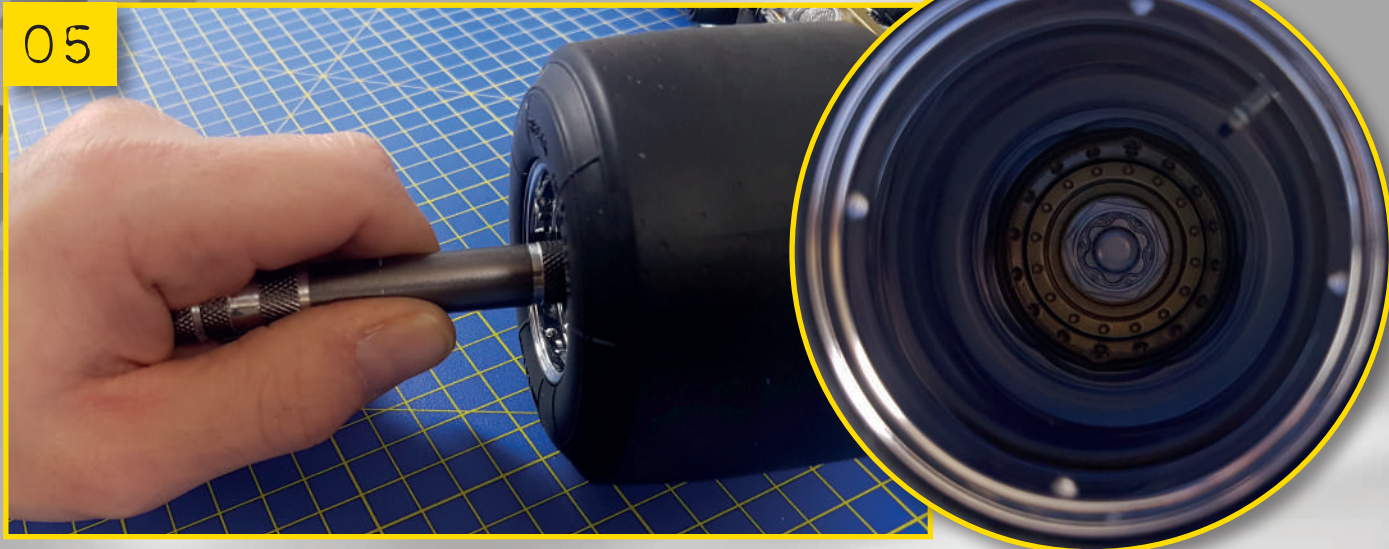

80-05 Use a type L screw to secure the wheel to the hub. Place the hubcap in the centre of the rim and press it into place.



FINAL RESULT

The left rear wheel is now fitted to your model.

In the next stage

The next stage will include parts for the right rear wheel and decals that will be applied to the four rims.



COMPONENTS FOR THE RIGHT REAR RIM

AS YOU DID FOR THE LEFT REAR WHEEL, YOU CAN ASSEMBLE AND ATTACH THE FINAL WHEEL TO YOUR MODEL. FOLLOW THE INSTRUCTIONS AND THE ACCOMPANYING IMAGES.



LIST OF PARTS

- 1 Four decals
- 2 Rim body
- 3 Rear rim closure
- 4 Five security pins
- 5 Hubcap

SCREWS

- Three type A screws
- Two type L screws



01

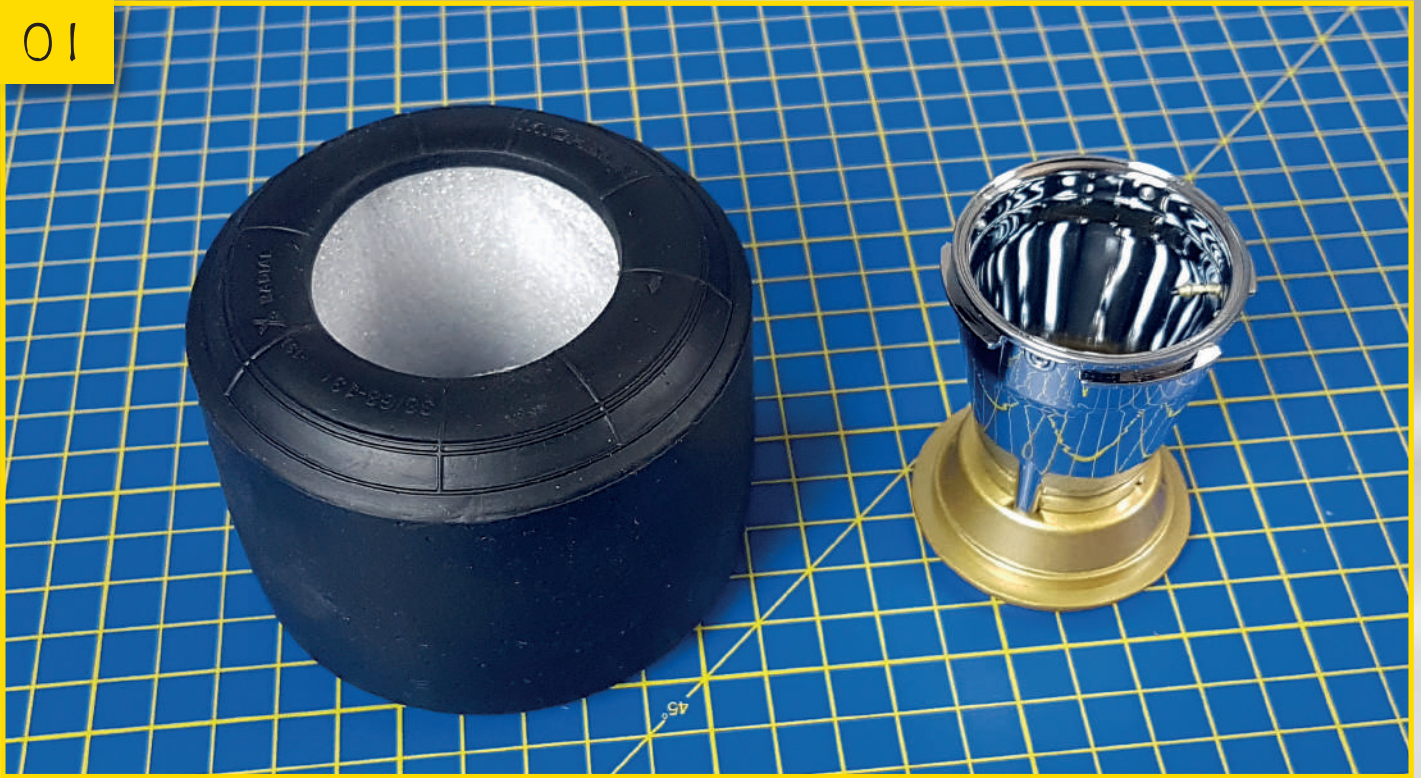

81-01 Place the right rear tyre (stage 80) and the second rear rim on your work surface. To assemble, follow the instructions in stage 79.

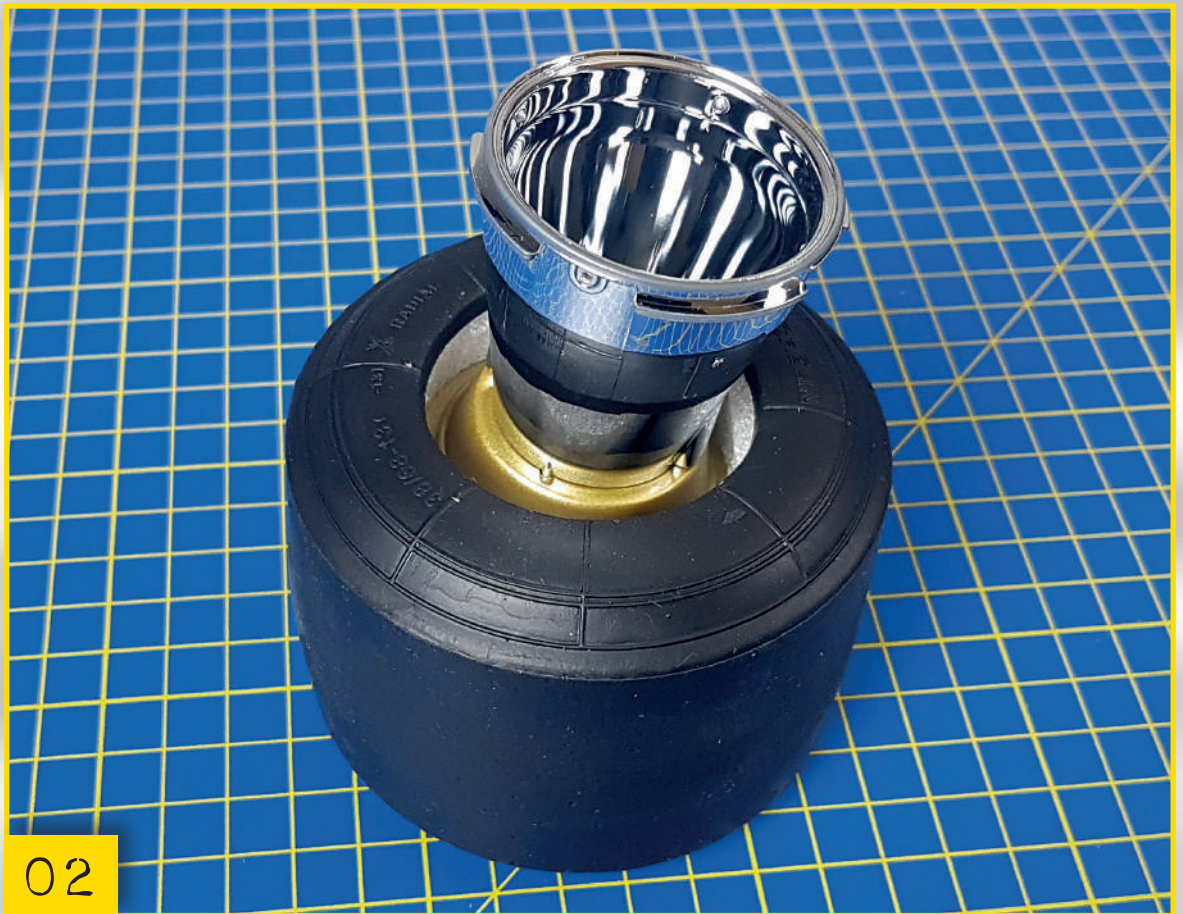

02

81-02 Insert the rim in the tyre. Make sure that the tyre lips match perfectly with the rim on both sides of the wheel.



03

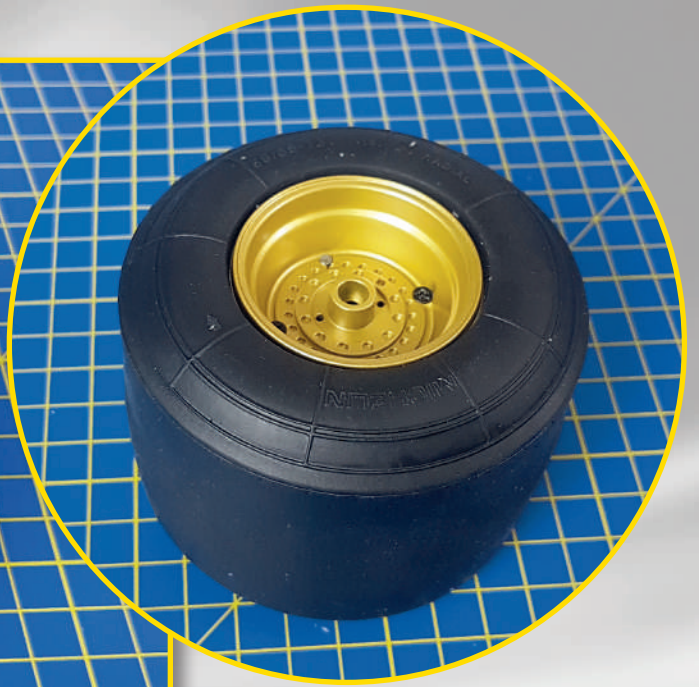

81-03

This is how the two sides of the right rear wheel will look when the rim has been correctly inserted.



04

81-04

Place the completed wheel, hubcap and type L screw on your work surface.



05

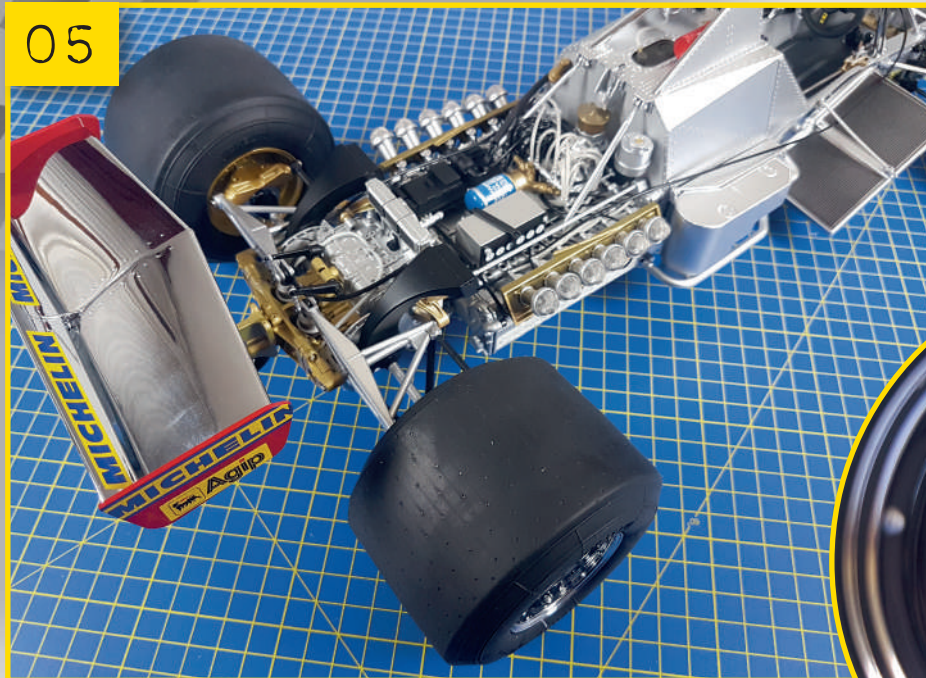

81-05

Press the wheel onto the rear right hub and secure it with the type L screw. Finally, fit the hubcap which simply presses into place.

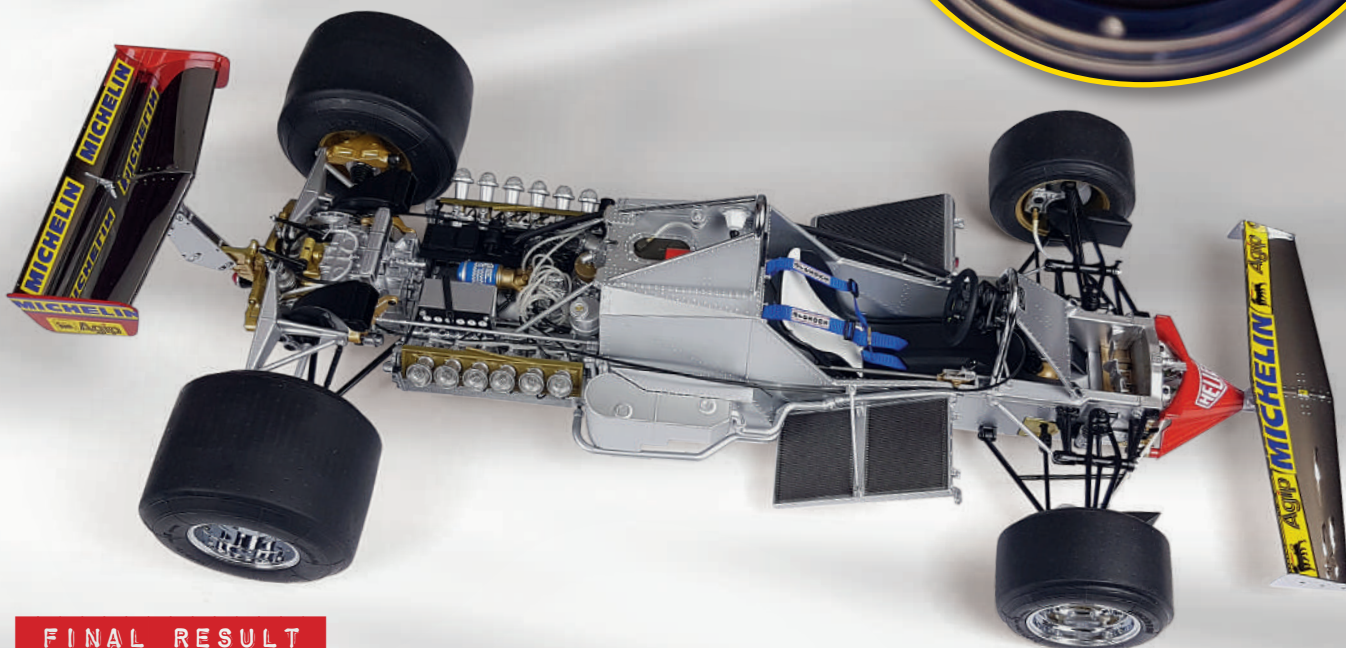
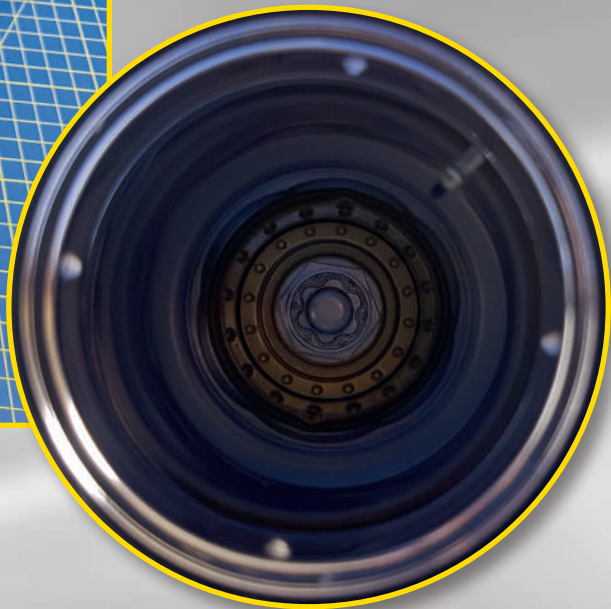

FINAL RESULT

Your model now has all four wheels. Put it carefully to one side. Also keep the four decals to one side, ready to be used in a future stage.

In the next stage

With the next stage, you will receive the exhaust pipe supports.



EXHAUST PIPE SUPPORT END PLATES

STAGE 82 INCLUDES THE END PLATES THAT SERVE TO SECURE AND SUPPORT THE EXHAUST PIPES THAT WILL BE SUPPLIED IN THE NEXT STAGE. IT ALSO INCLUDES THE CONNECTOR THAT WAS USED TO RECHARGE THE VEHICLE BATTERY.

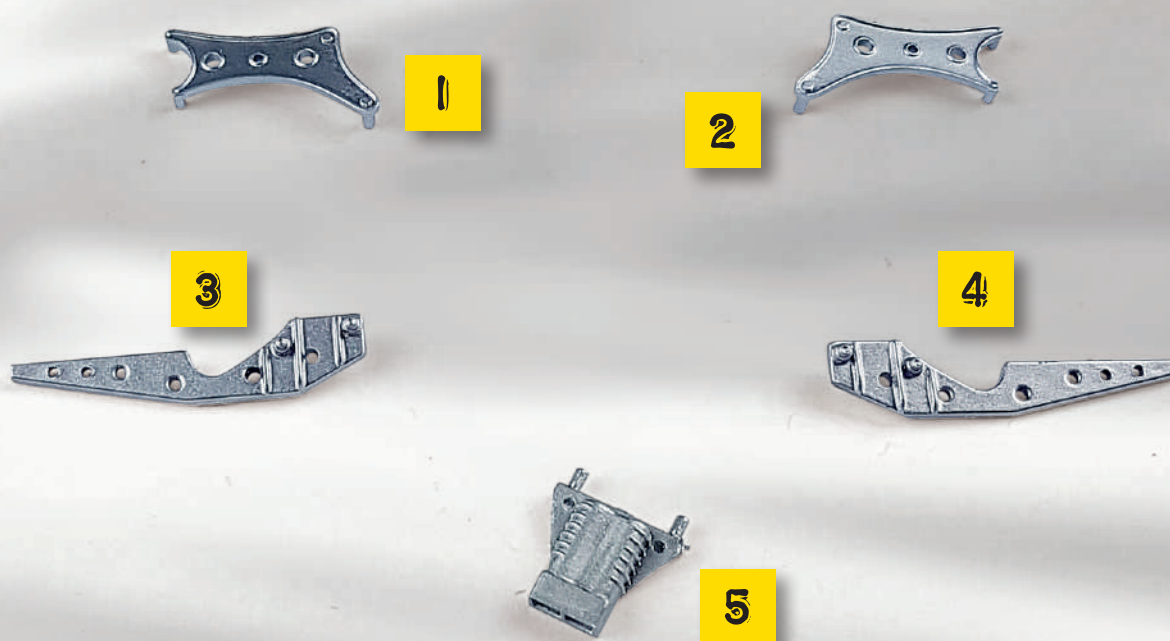

LIST OF PARTS

- | | | | |
|---|-------------------|---|-------------------|
| 1 | Right rear plate | 4 | Left front plate |
| 2 | Left rear plate | 5 | Battery connector |
| 3 | Right front plate | | |



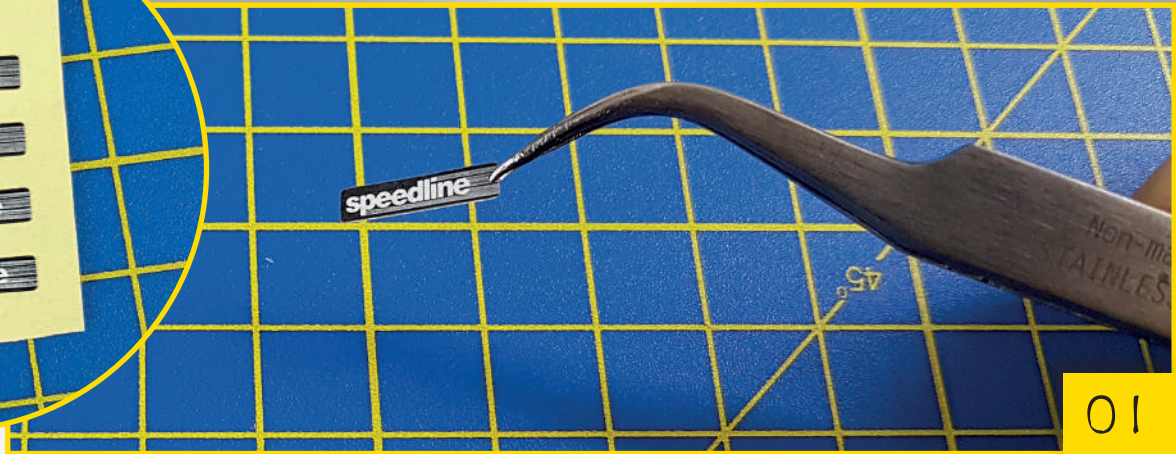
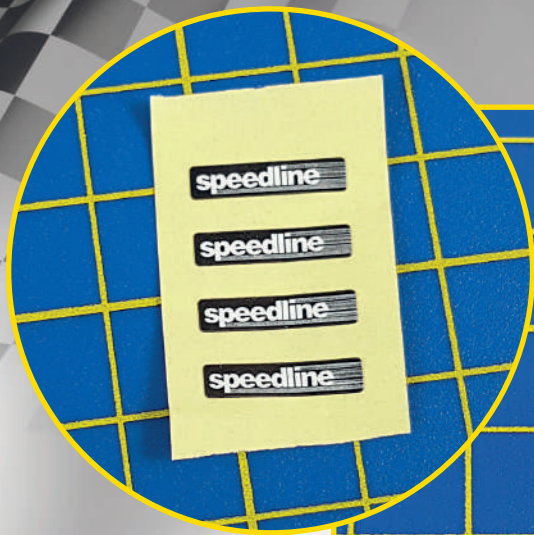

82-01 Take the four decals included with stage 81. Using curved nose pliers, lift off the first decal as shown.

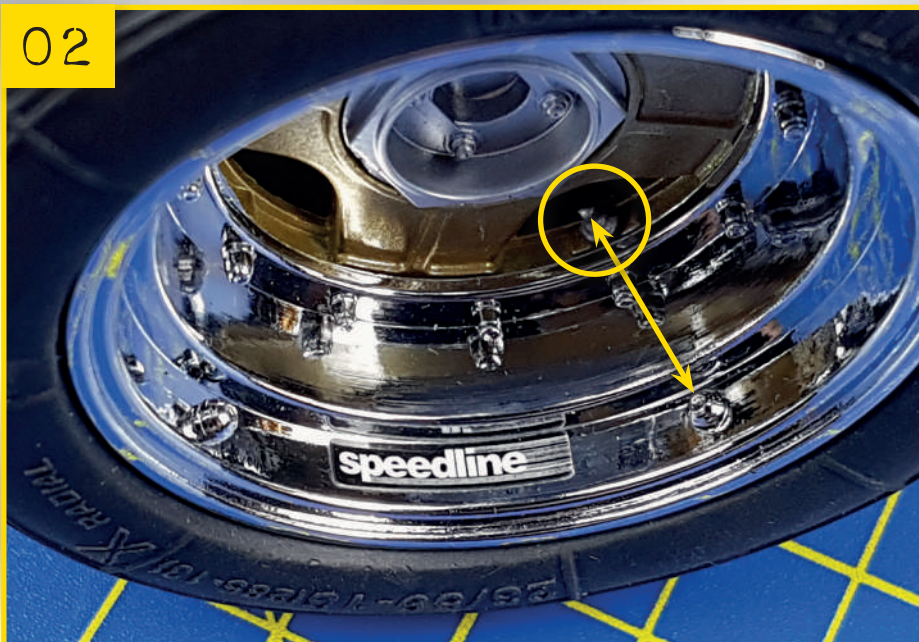

82-02 Apply the decal, positioning it halfway between two security pins on the front rim. Make sure the inflation valve is level with the security pin on the right of the decal. Repeat these steps on the second front rim.

82-03 Place the third decal on the rear rim, between the two security pins. In this case, the inflation valve must be between the two pins. In the same way, apply the last decal to the second rear rim.



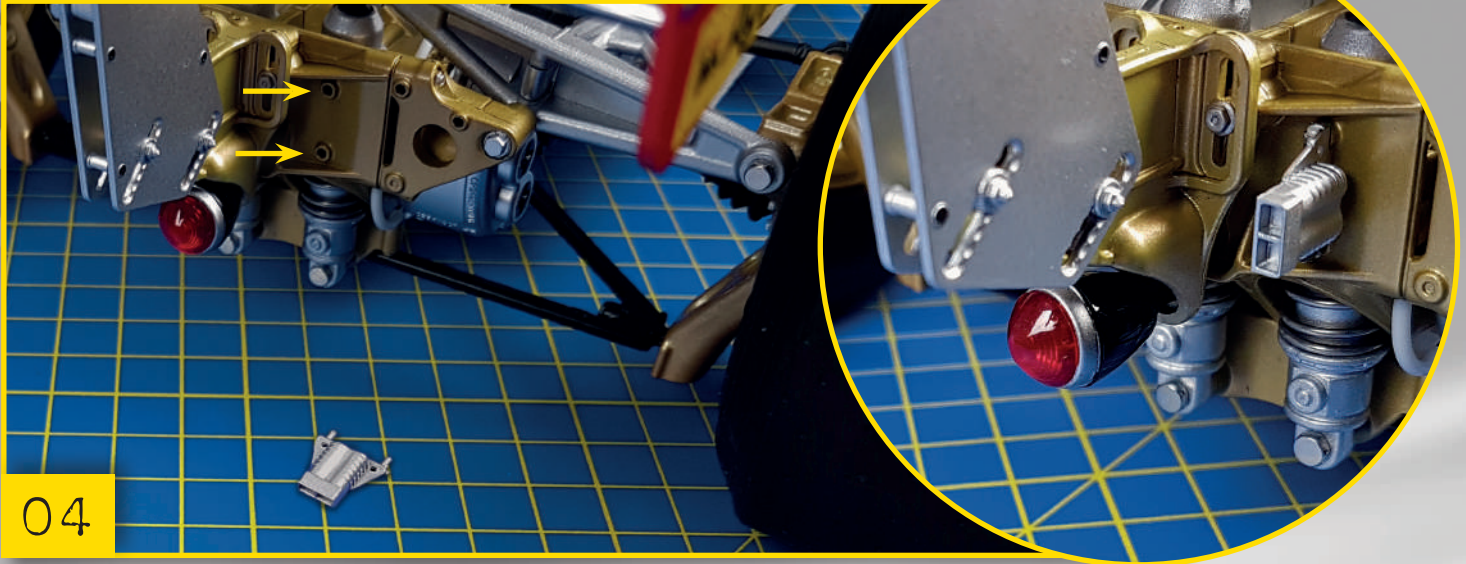

04

82-04 The battery connector has two pins that must be inserted into the two holes shown on the photo above. This part simply presses into place. The part should look as shown in the inset image once fitted.

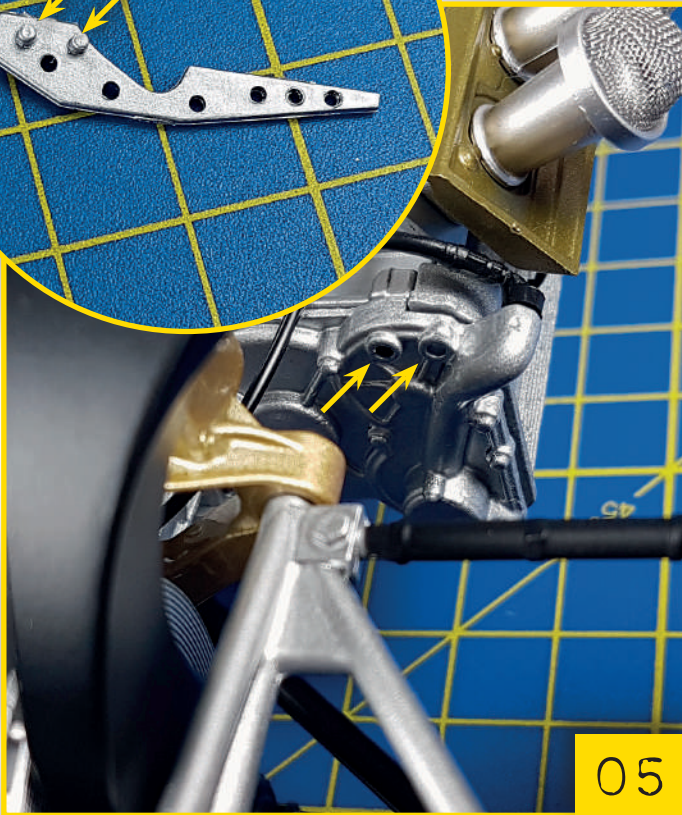
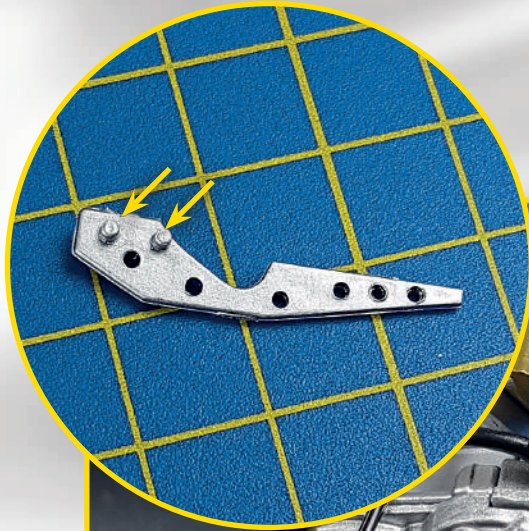

82-05 Take the front plate. It has two pins that need to be inserted into the assembly holes at the back, on the right side of the engine.

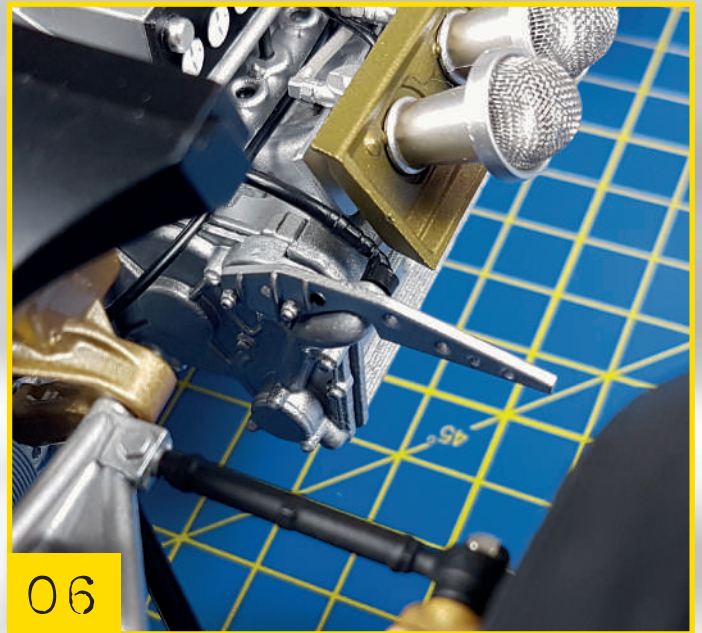

82-06 Using the joints highlighted in the previous step, press the right plate into place.



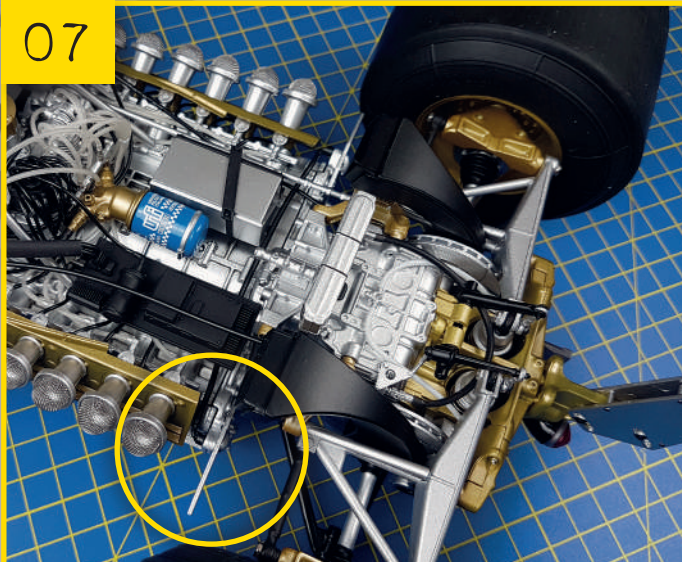

07

82-07 Follow the same steps to fit the left front plate on the engine.

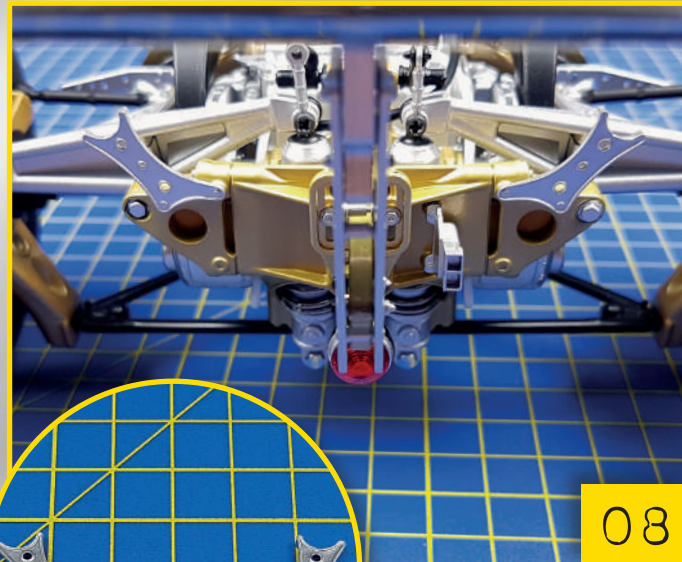

08

82-08 Take the two rear plates and attach them to the suspension support. Each plate has two pins that need to be inserted into the assembly holes. Make sure they are facing the same way as shown in the images.

FINAL RESULT

This is what your model will look like at the end of this stage.

In the next stage

The first parts you will use to build the exhaust system.

