

Pack 9

LaFerrari

1:8 SCALE

THE ULTIMATE HYPERCAR
ULTIMATE PERFORMANCE
ULTIMATE STYLE

AGORA
MODELS®



STAGE 65 THE LEFT DOOR (3)

LIKE THE RIGHT, THE LEFT DOOR OF YOUR 1:8 SCALE LAFERRARI REPLICA IS ALSO CHARACTERIZED BY A COMPLEX AND ARTICULATED STRUCTURE, THE RESULT OF CAREFUL DESIGN

PARTS LIST

NO.	PART	QUANTITY	MATERIAL
1	Left door interior	1	ABS
2	Left door front panel	1	ABS
3	Left door detail	1	ABS
4	Upper interior lining	1	ABS
5	Screw type AA	1	Metal
6	Screw type Q	2	Metal
7	Screw type G	3	Metal



STEP 1

Retrieve the left door assembly (stage 64). Fit the detail (3) on the inner side of the door and secure with a type AA screw (5).

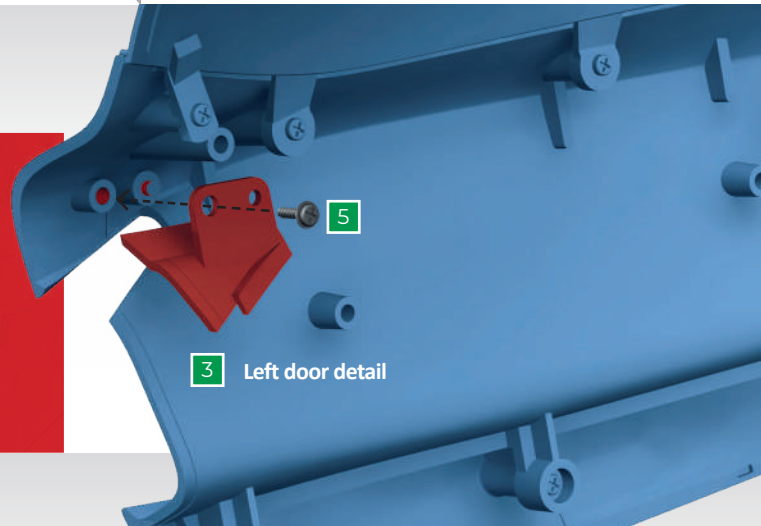

STEP 2

Fit the front panel (2) onto the left door interior (1) in the orientation shown. Secure with two type Q screws (6).

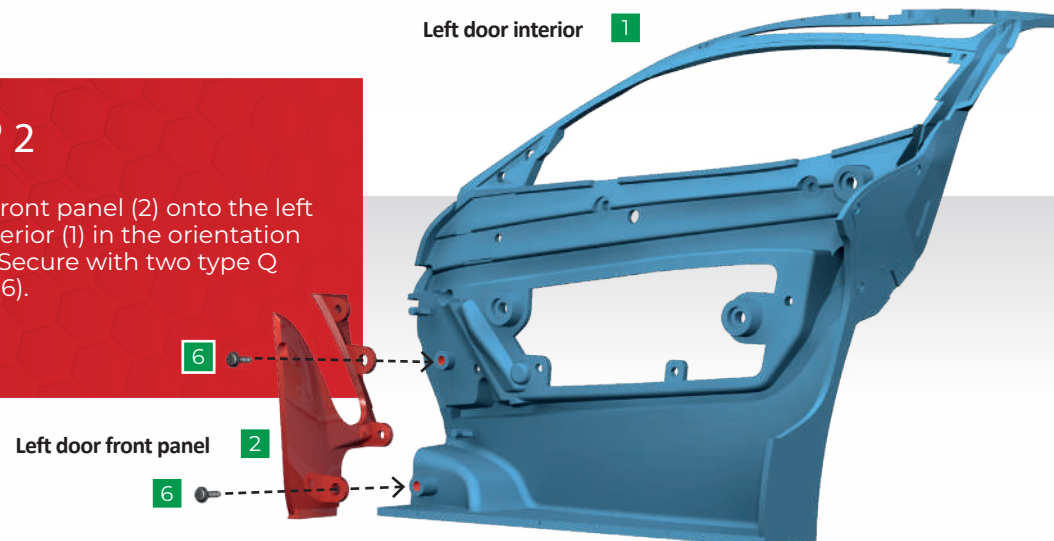

STEP 3

Position the interior onto the left door assembly and secure using three type G screws (7). Press the upper interior lining (4) in place as shown.

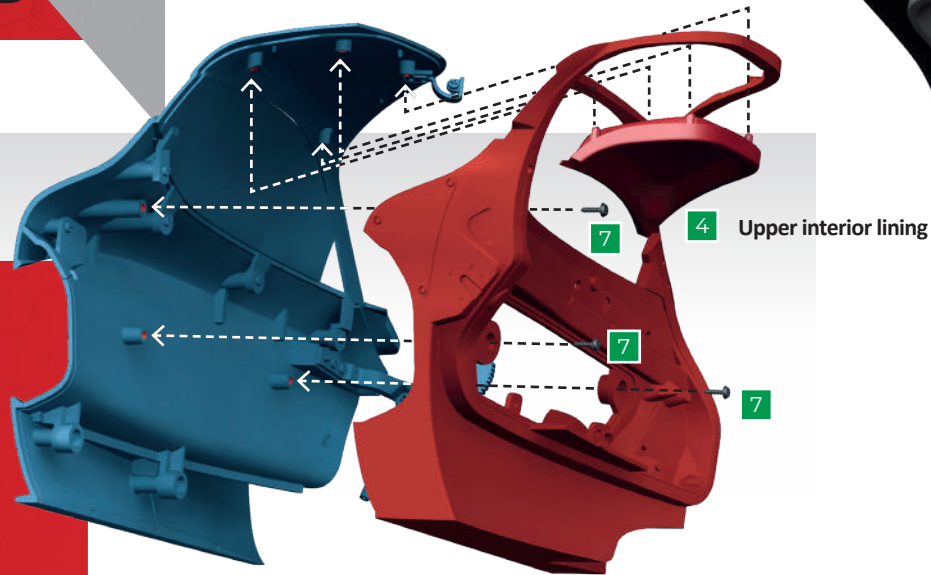

Left door interior 1

STAGE COMPLETE

The left door of your model is almost complete. You'll continue assembly in the next stage by adding more details then mounting both doors onto the model.



STAGE 66 THE LEFT DOOR (4)

THE DOOR OPENING SYSTEM OF LAFERRARI IS QUITE UNIQUE, WITH THE DOORS OPENING UPWARDS, AS IS THE LATEST TREND IN THE SUPER SPORTS CAR SECTOR

PARTS LIST

NO.	PART	QUANTITY	MATERIAL
1	Left door interior panel	1	ABS
2	L-shaped panel	1	ABS
3	Armrest	1	ABS
4	Screw type N	2	Metal



STEP 1

Press the interior panel (1) into the left door assembly (stage 65).

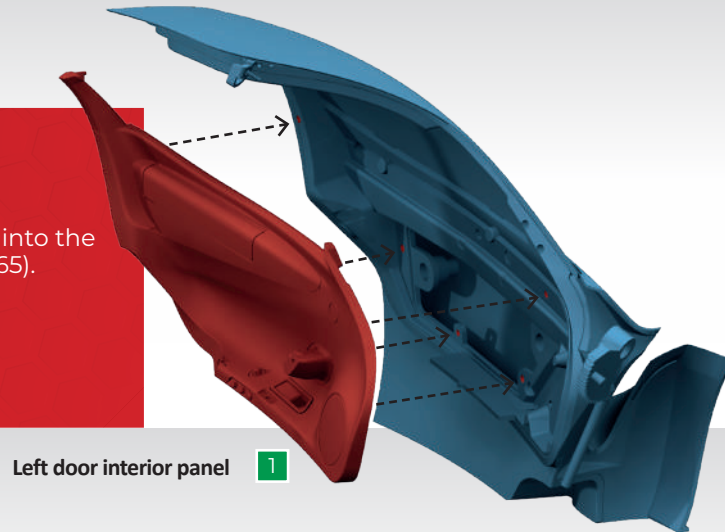

STEP 2

Fit the armrest (3) onto the interior panel as shown.

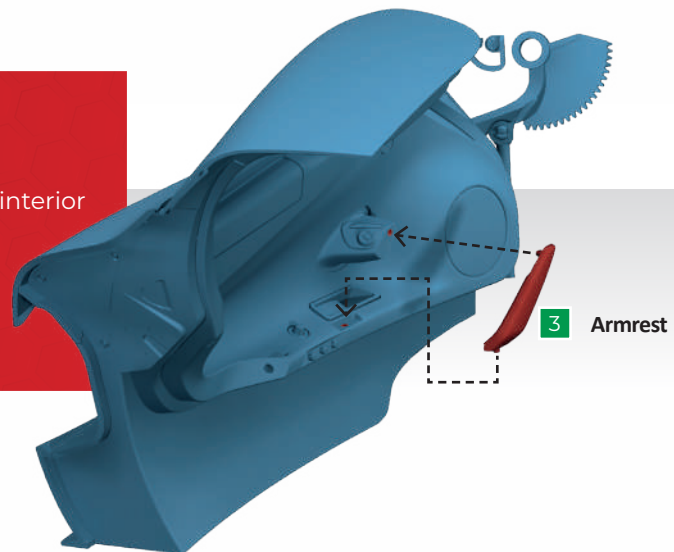

STEP 3

Push the L-shaped panel (2) into the interior panel.

L-shaped panel **2**

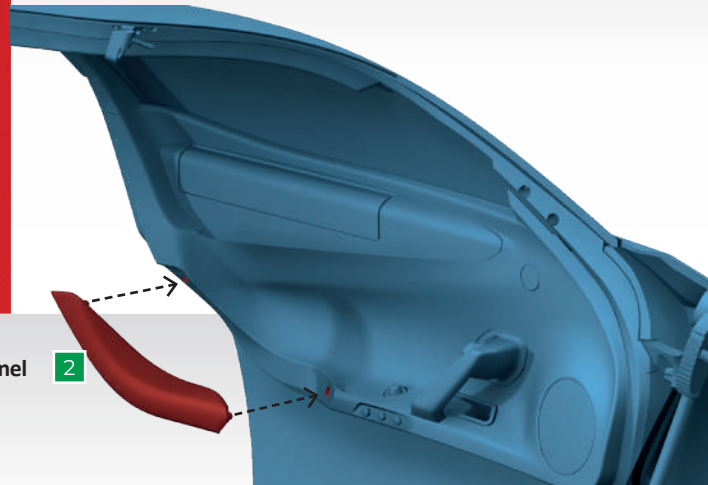

STEP 4

Retrieve the right door assembly (stage 62). Mount the right door by fitting it to the two connection points: one at the front of the windscreen and the other on the roof. Use a type N screw (3) to secure the front connection.

3

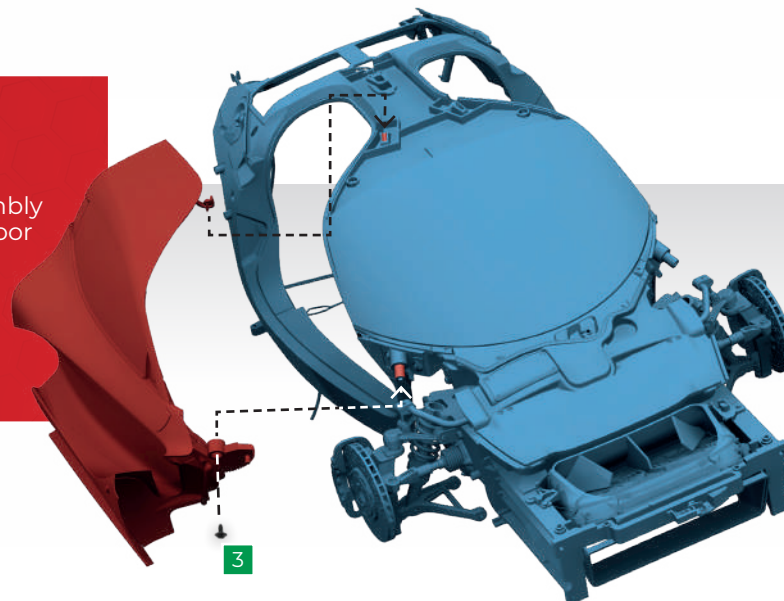

STEP 5

Mount the left door in the same way, securing the front connection with a type N screw (3).

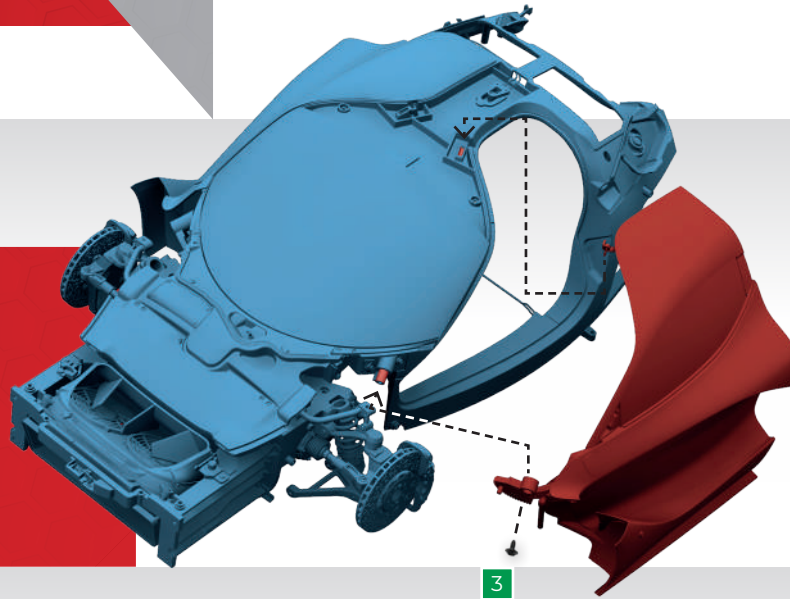

STAGE COMPLETE

Both doors have been installed onto your model. The upper pivots of the doors are incomplete, they will operate after the roof is mounted. Take care when storing the model, as the doors are not yet fixed in place.



STAGE 67 THE CIRCUIT BOARD

YOUR 1:8 SCALE REPLICA OF LAFERRARI IS EQUIPPED WITH ELECTRONIC FUNCTIONS THAT ENHANCE ITS AUTHENTICITY, ALL CONTROLLED BY THE CIRCUIT BOARD

PARTS LIST

NO.	PART	QUANTITY	MATERIAL
1	Roof (top part)	1	ABS
2	Circuit board	1	Varied
3	Screw type EE*	4	Metal
4	Screw type I	3	Metal
5	Screw type F	2	Metal
6	Screw type P	2	Metal

* Screws type EE are provided with this stage. Spares have been included.

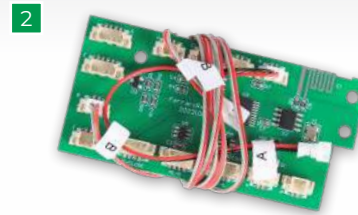

STEP 1

Install the roof by pushing it into the four mounting holes. Secure the front with two type F screws (5) then the rear with two type P screws (6).

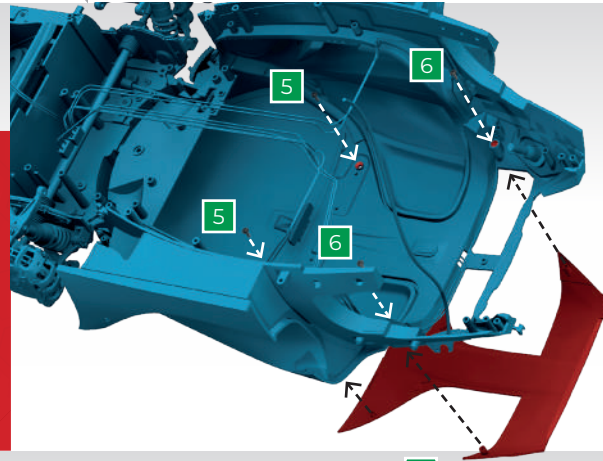

Roof (top part) 1



STEP 2

Retrieve the two sun visors from stage 57 and fit them in place as shown. Arrange the wires from the fans, door switches, and overhead light as shown on the right image.

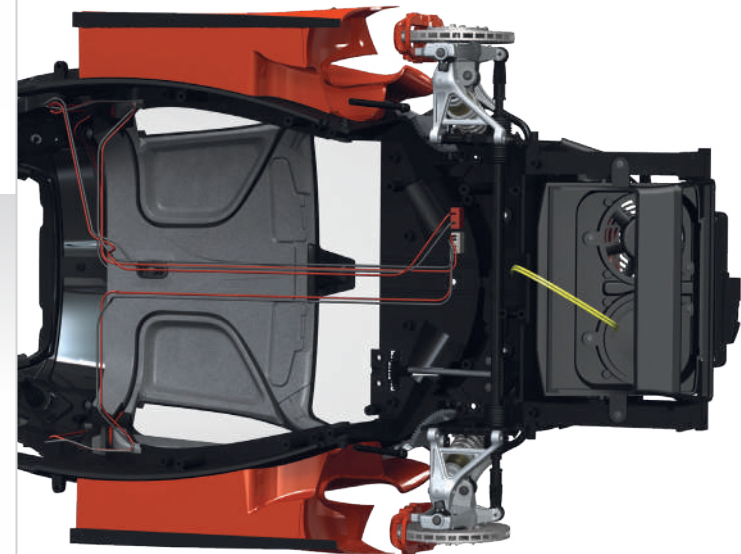
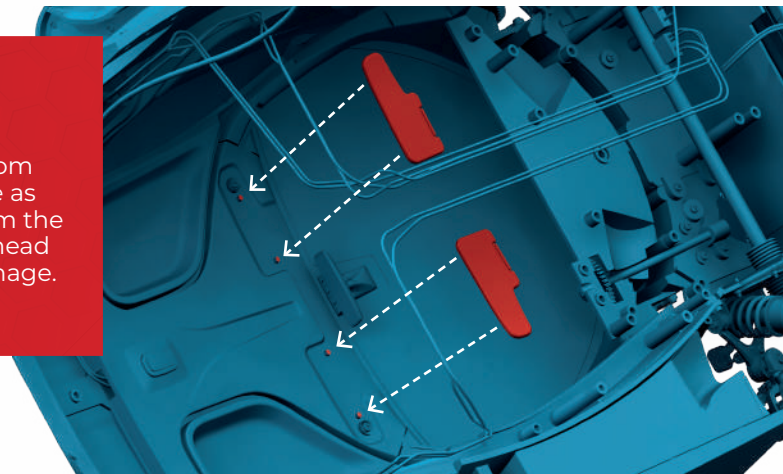

STEP 3

Install the circuit board (2) then secure with three type I screws (4).

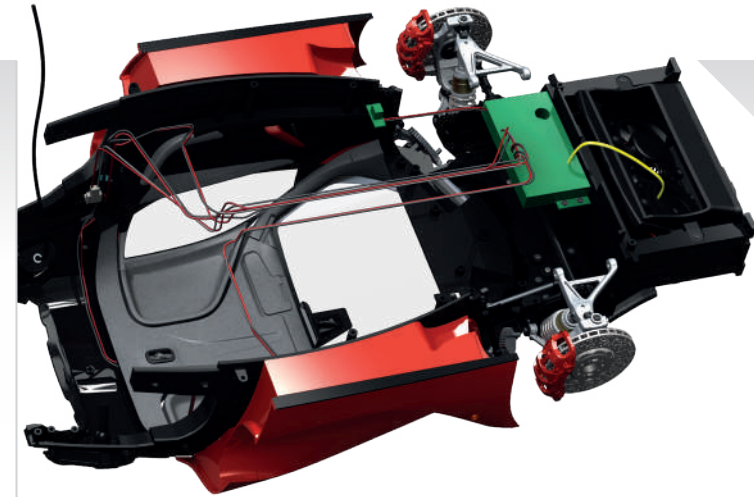
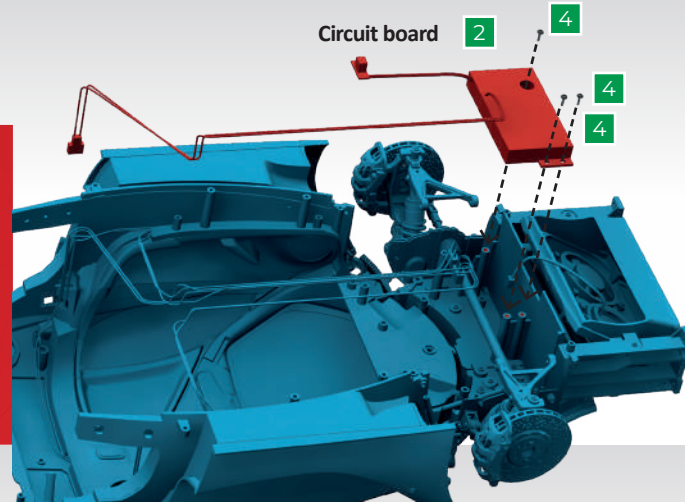

STEP 4

Fit the upper cover panel (stage 56) in place, running the overhead light cable underneath the part so that it exits near the electric refueling cap.

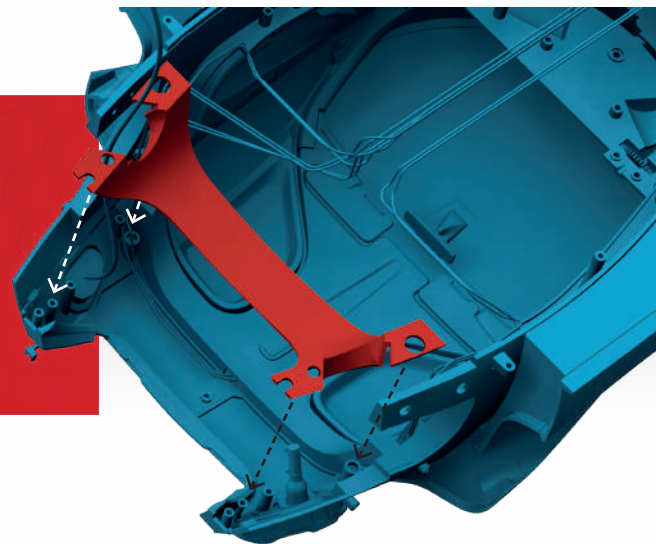

STEP 5

Retrieve the upper rear subframe (stage 52) and secure it to the main chassis with four type EE screws (3).

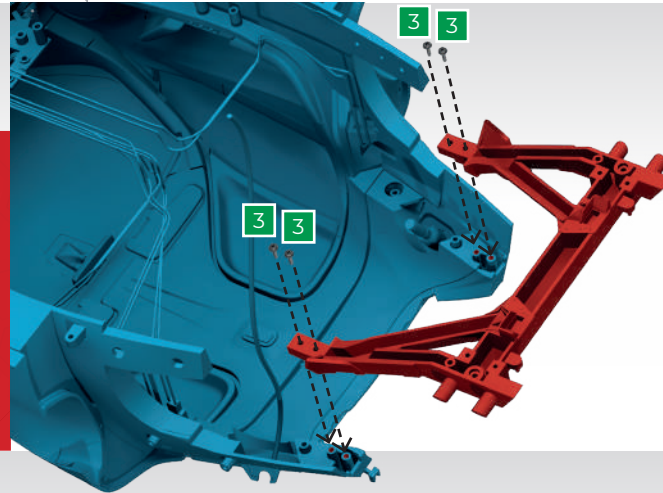

STEP 6

Retrieve the two uprights (stage 42) and install them into the subframe as shown. These are push-fit connections, but you can use a drop of super glue to secure if needed.

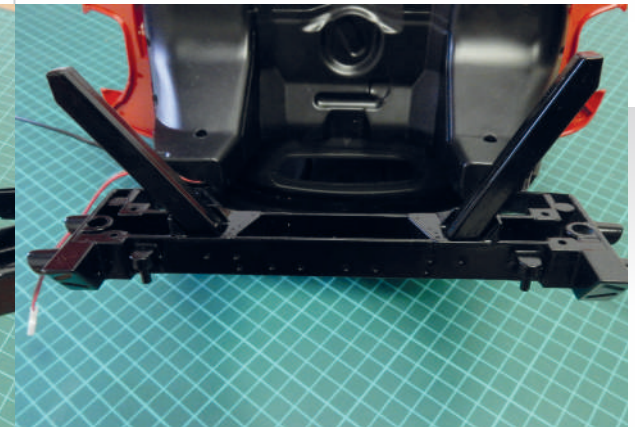

STAGE COMPLETE

The circuit board has been installed.



STAGE 68 THE DOOR CONTROL MOTORS

THE DOORS OF YOUR REPLICA
FEATURE AUTOMATICALLY
OPENING AND CLOSING
FUNCTIONS, POWERED BY TWO
DEDICATED ELECTRIC MOTORS

PARTS LIST

NO.	PART	QUANTITY	MATERIAL
1	Tank bulkhead	1	ABS
2	Left door motor	1	Varied
3	Right door motor	1	Varied
4	Door motor bracket	2	ABS
5	Door piston rod	2	Metal
6	Screw type G	12	Metal
7	Screw type N	2	Metal
8	Screw type GG*	1	Metal

* Screws type GG are provided with this stage. A spare has been included.

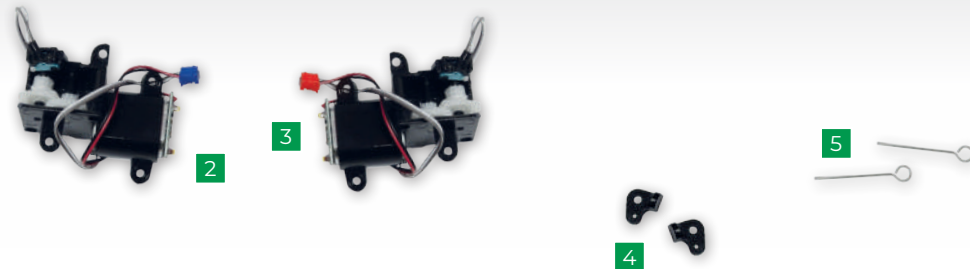

This stage is more complex than the previous stages of your build. To help with this, the illustrations have been replaced with photographs of the steps required for assembly.

Before starting this stage, check the rack shaft from stage 52 is installed correctly. Here are some additional photographs to help you check. Once you are happy, proceed to step 1.

- A** Hold the rack shaft above the frame's opening with the teeth pointing sideways.
- B** Twist the rack shaft so that the teeth fit into the opening.
- C** Lower the rack shaft into place then orient it so that the teeth point upwards as shown.



STEP 1

Insert a rod (5) into a piston of one of the two doors, orienting the rod so that the inserted end faces outward from the model. Secure the loop of the rod using a type N screw (8) as shown. Repeat this process for the other door.

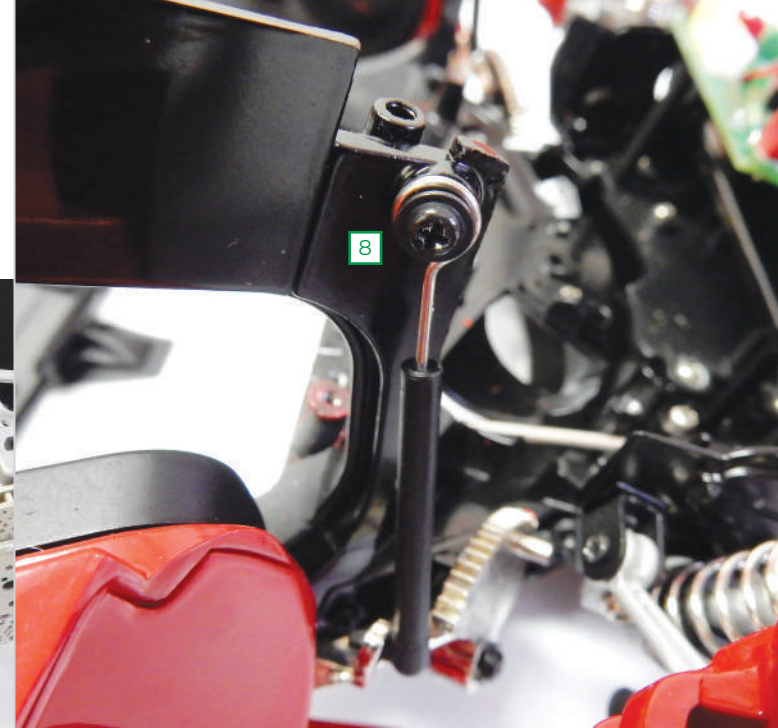
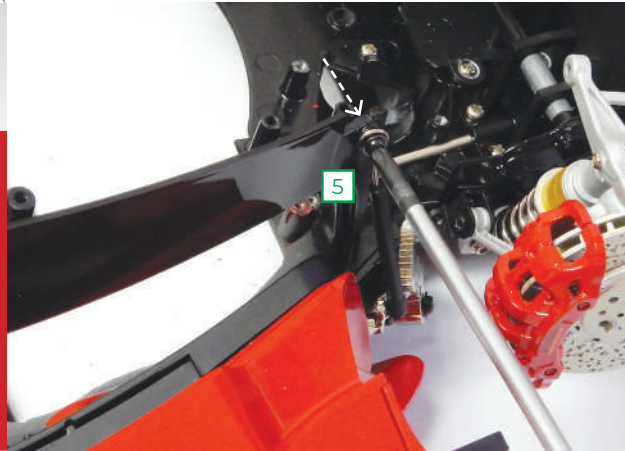

STEP 2

Fit the motor brackets (4) next to the recesses as shown, securing each one in place with a type G screw (6).

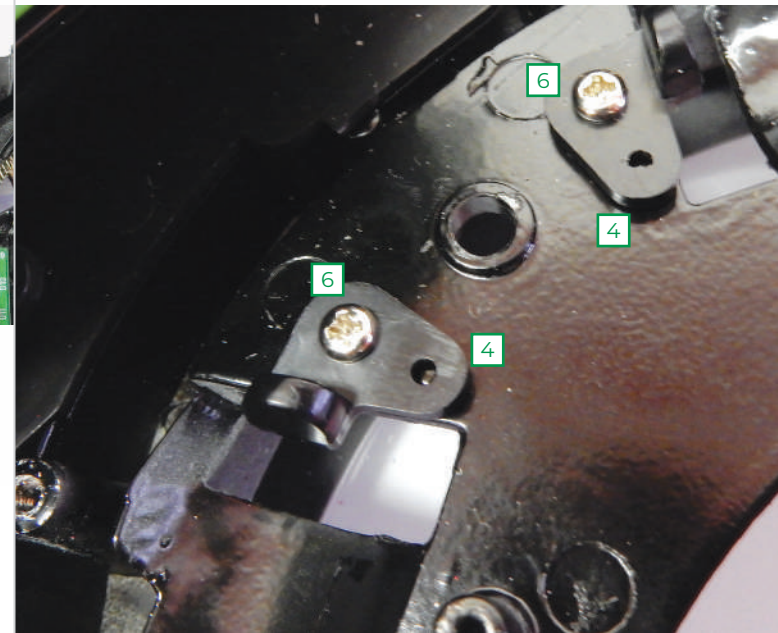
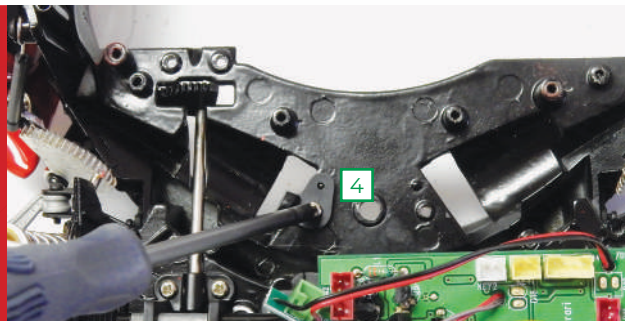

STEP 3

Remove the steering shaft from the dashboard and retrieve the rack shaft guard detail B (from stage 52). Fit the shaft and guard as shown, securing the guard with two type G screws (6). With the wheels straight, the flat of the shaft should face towards the passenger side (red arrow).

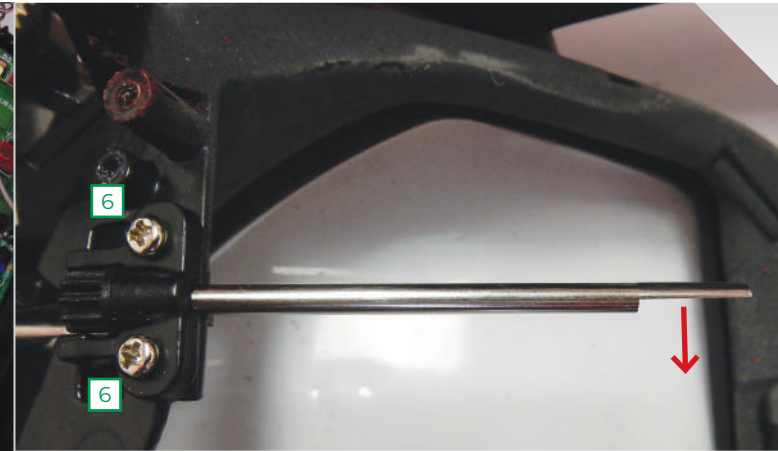
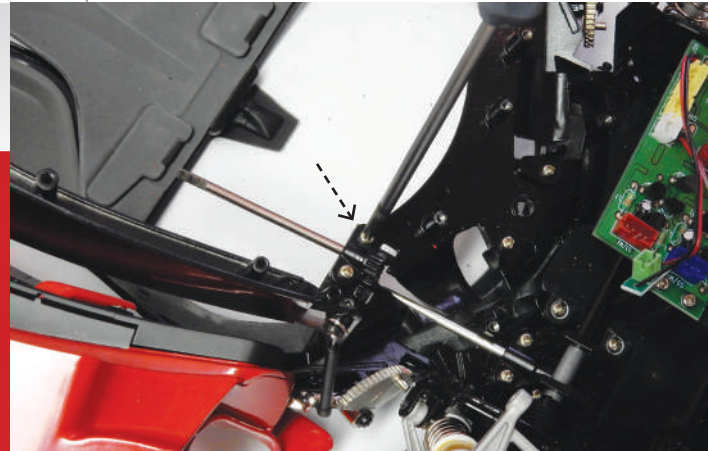

STEP 4

With the doors closed, fit the left (2) and right (3) motors. Secure using eight type C screws in the points indicated by the white circles.

The circuit board provided will look different to the one in the image, but this will not affect its use.

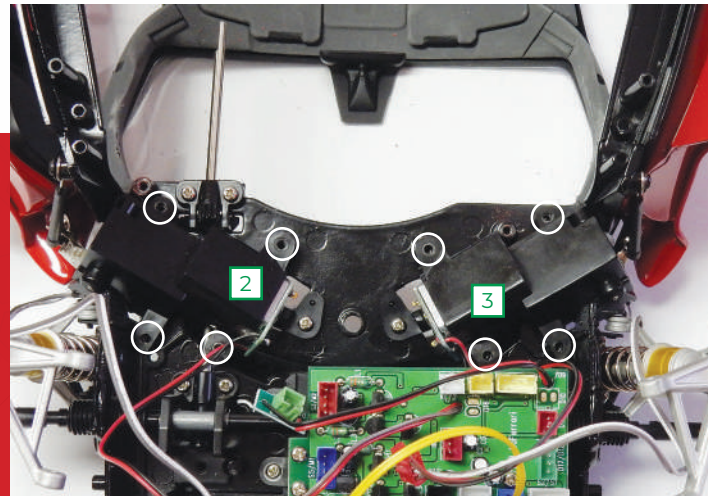

STAGE COMPLETE

The installation of the door motors will hold them in place, making it easier to store safely.

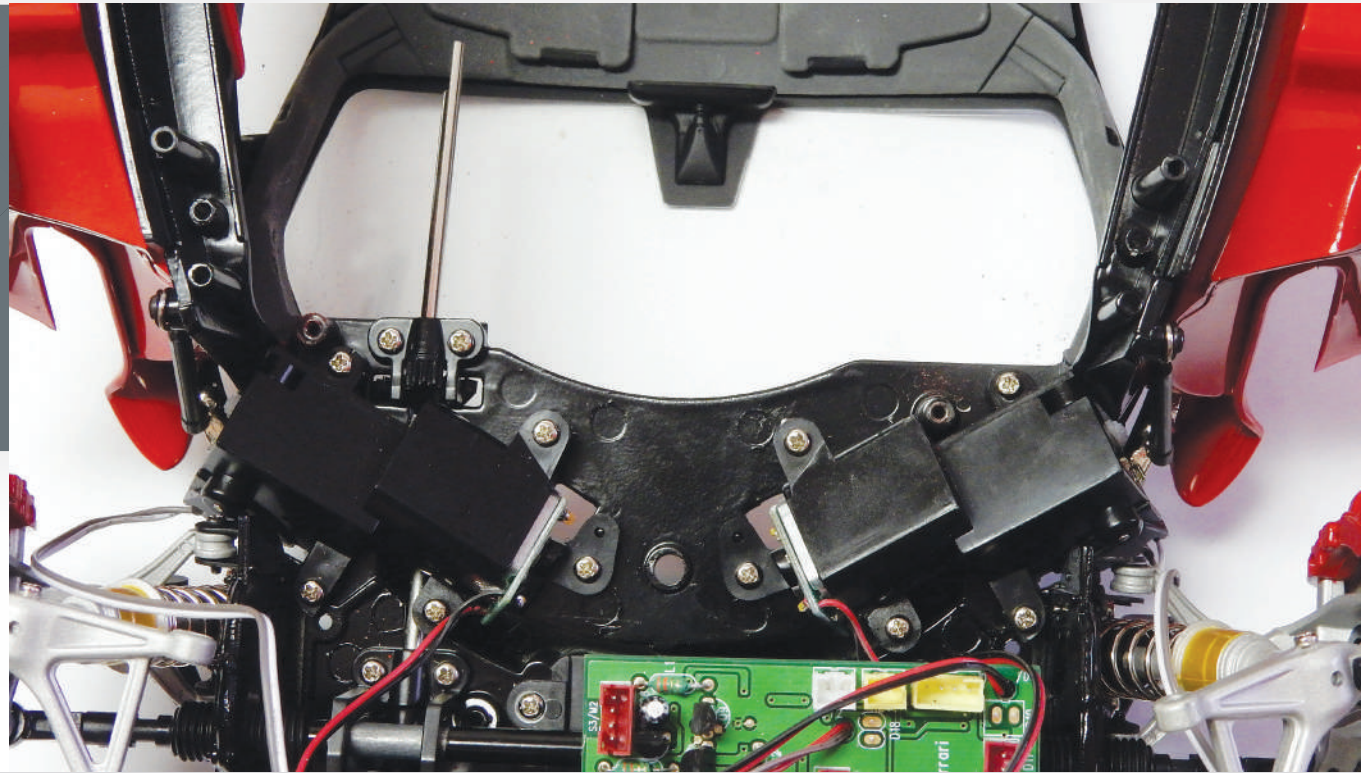

STAGE 69 THE REAR LEFT FENDER

THE USE OF CARBON FIBRE, A LIGHTWEIGHT AND ROBUST MATERIAL, ADDS PRESTIGE AND CHARM TO THE LAFERRARI

PARTS LIST

NO.	PART	QUANTITY	MATERIAL
1	Rear left fender	1	ABS

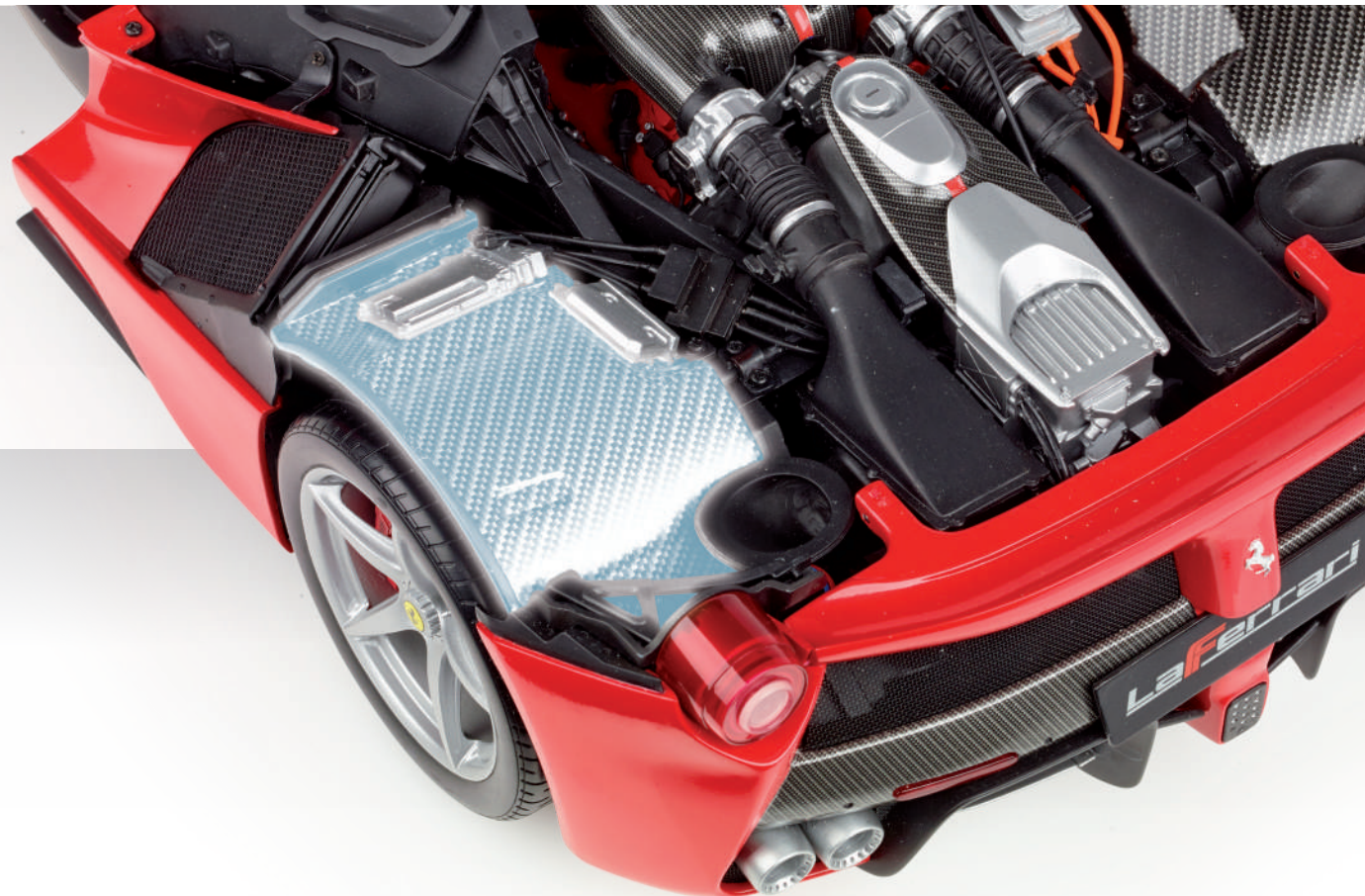

STEP 1

Retrieve detail A (stage 46) and press onto the rear left fender (1). The fittings are different sizes (circled) to ensure the correct orientation.

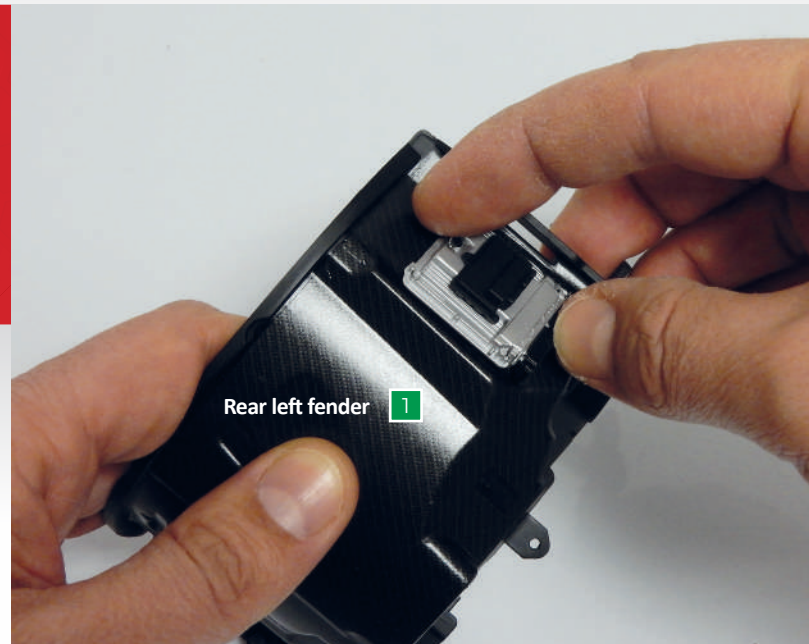

STEP 2

Fit detail B (stage 46) in position on the rear left fender (1) as shown in the images.

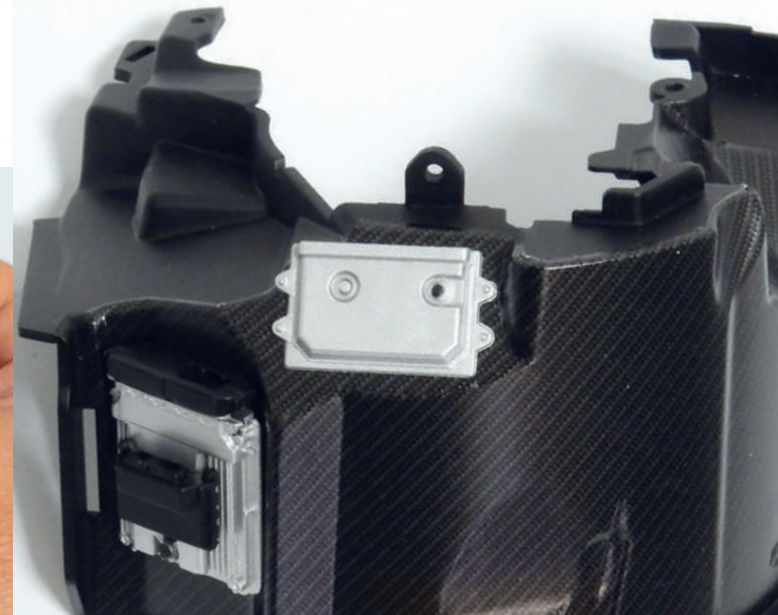

STAGE COMPLETE

The rear left fender has been prepared for installation. Store it away carefully until it is needed.

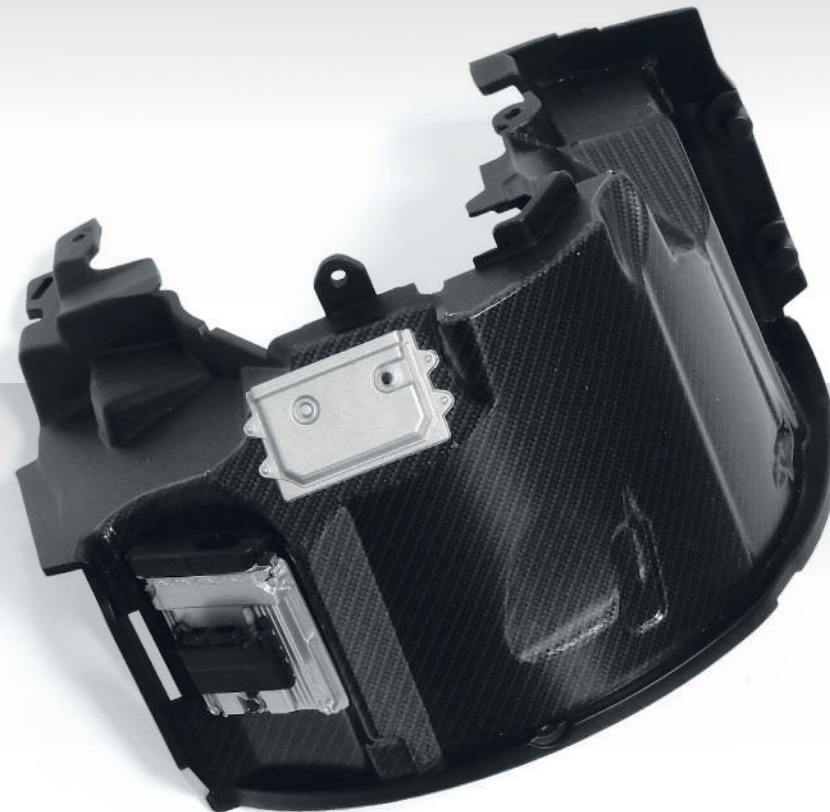

STAGE 70 THE REAR RIGHT FENDER

AN AFTERTHOUGHT ON MOST CARS, THE HIGH DEGREE OF FINISHING ON COMPONENTS LIKE THE FENDERS SETS THE LAFERRARI APART FROM OTHERS

PARTS LIST

NO.	PART	QUANTITY	MATERIAL
1	Rear right fender	1	ABS





STEP 1

Retrieve detail A (stage 48) and press into place on the rear right fender (1) as shown. The fittings are different sizes (circled) to ensure the correct orientation.



STAGE COMPLETE

The rear right fender has been prepared for installation. Store it away with the rear left fender until it is needed.



STAGE 71 THE FRONT FRAMES

WITH ITS FUTURISTIC DESIGN, THE LAFERRARI FEATURES LATTICE FRAMES MADE OF CARBON FIBRE INSIDE THE FRONT FENDERS

PARTS LIST

NO.	PART	QUANTITY	MATERIAL
1	Front left frame	1	Metal
2	Front right frame	1	Metal
3	Right air intake pipe	1	ABS
4	Left air intake pipe	1	ABS
5	Screw type N	2	Metal
6	Screw type A	2	Metal
7	Screw type J*	4	Metal
8	Bonnet cylinder bracket	1	ABS

* Screws type J are provided with this stage



STEP 1

Retrieve the nose assembly (stage 3) and fit the right air intake pipe (3), marked with an 'R'.

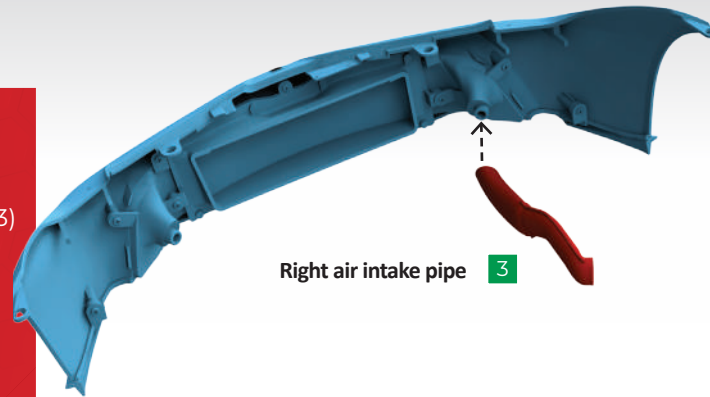

STEP 2

Fit the left air intake pipe (4), marked 'L', in place.

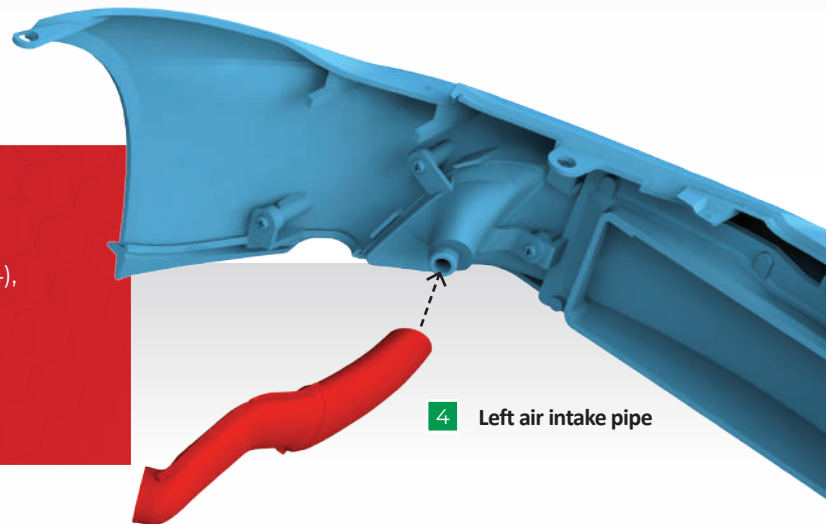

STEP 3

Fix the front right frame (2) onto the chassis, securing with two type J screws (7) and one type A screw (6).

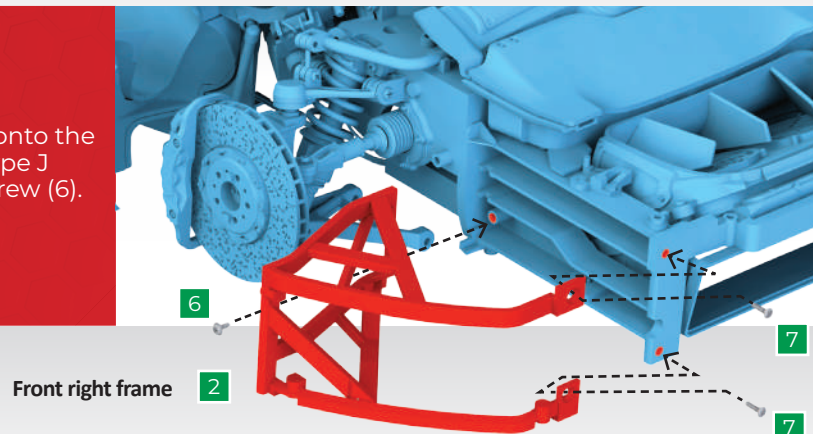

STEP 4

Fix the front left frame (1) to the chassis in the same way.

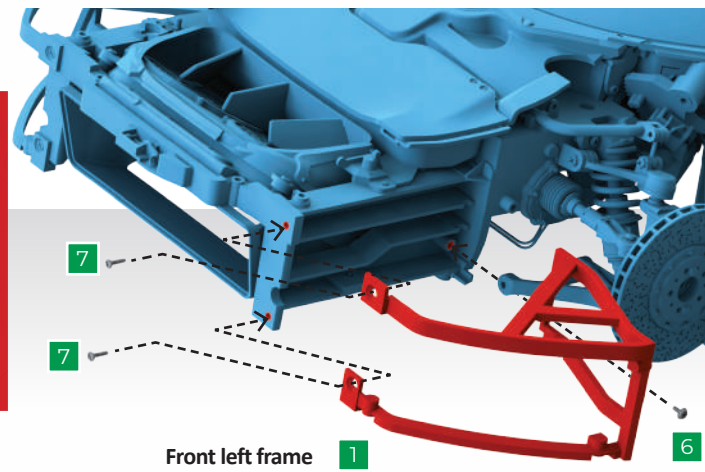

STEP 5

Fit the nose assembly onto the model as shown and secure using two type N screws (5).

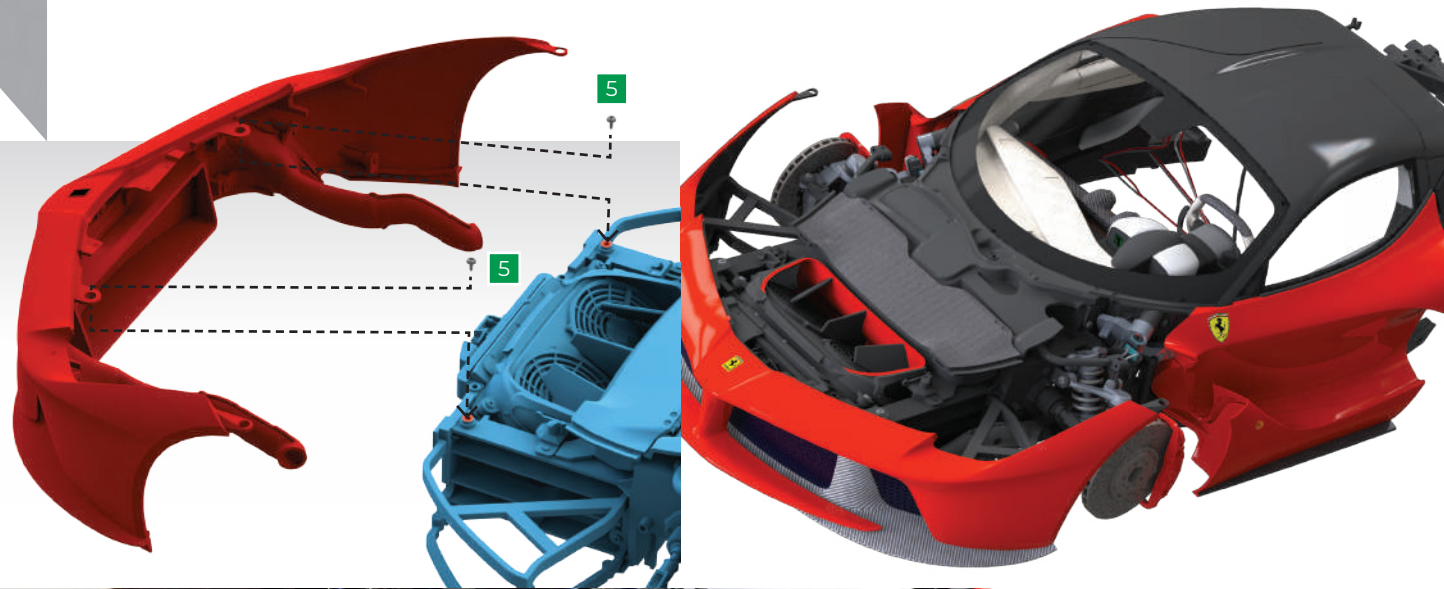

STAGE COMPLETE

The supporting frames and nose have been fitted to your model.



STAGE 72 THE FRONT LEFT WHEEL ARCH PANEL

EVERY SECTION OF THE
MARANELLO TWO-SEATER
CONTRIBUTES TO THE
STREAMLINED DESIGN AND
AERODYNAMIC QUALITIES

PARTS LIST

NO.	PART	QUANTITY	MATERIAL
1	Front left wheel arch panel	1	Metal

Note there is no assembly in this stage. Keep the part safe until it is needed in the next pack.

